

REVISIONS					
REV	ECO	DESCRIPTION	DATE	BY	APPR
B1	-	RELEASED DRAWING	JUN-28-2014	BEN	TOMMY

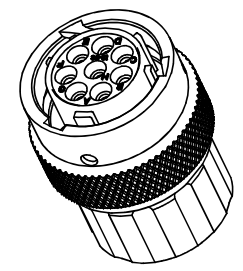
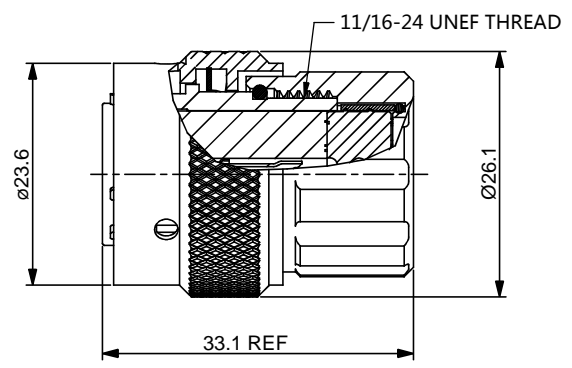
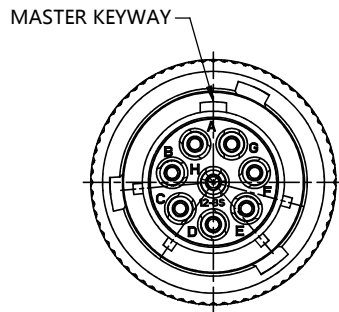

**NOTES : (UNLESS OTHERWISE SPECIFIED)**

- MATERIAL :**  
 SHELL : ZINC ALLOY , NICKEL PLATED.  
 INSERT : THERMOPLASTIC , UL94 V-0.  
 END CAP : THERMOPLASTIC , UL94 V-0.  
 COUPLING NUT : AL ALLOY , NICKEL PLATED.  
 WAVE WASHER : STAINLESS STEEL.  
 O-RING : NBR.  
 WIRE SEAL : SILICONE RUBBER.  
 PLASTIC BUSHING : THERMOPLASTIC , UL94 V-0.
- SPECIFICATIONS :**  
 2.1 RATED CURRENT : 13A (MAX).  
 2.2 RATED VOLTAGE : 300V ( AC/DC ) .  
 2.3 OPERATING TEMPERATURE : -40°C ~ +105°C.  
 2.4 DIELECTRIC WITHSTANDING VOLTAGE : LESS THAN 2 MILLIAMPS CURRENT LEAKAGE@2000 VOLTS AC.  
 2.5 INSULATION RESISTANCE : 5000 MEGOHMS MIN.  
 2.6 IP--CLASS : IP67.  
 2.7 MATING CYCLES DURABILITY : 500 CYCLES(MIN).  
 2.8 ROHS COMPLIANT.
- SUITABLE CONTACTS : 16# CONTACTS.**
- ALL DIMENSIONS ARE FOR REFERENCE USE ONLY.
- CONTACT SIZE AND REAR SEAL WIRE RANGE :**

CONTACT SIZE	MIN. INSUL O.D.	MAX. INSUL O.D.	WIRE RANGE
16#	Ø2.0mm	Ø3.2mm	14 - 24AWG

KEY POS	PART NUMBER
N	RT06128SNHEC
W	RT06128SWHEC
X	RT06128SXHEC
Y	RT06128SYHEC
Z	RT06128SZHEC

QUANTITY	SEE PART NUMBER CHART	DESCRIPTION	ITEM

MATERIALS LIST			
UNLESS OTHERWISE SPECIFIED 1) All dimensions are in metric(mm). 2) Tolerances are as follows: 1 PL DEC ±0.30   Fractions ±1/64 2 PL DEC ±0.15   Angles ±1° 3 PL DEC ±0.08 3) Note reference =	SIGNATURES DRAWN: BEN CHECKED: ENGINEER: APPROVAL:	DATE JUN-28-2014	<h1>Amphenol</h1> Sine Systems - www.amphenol-sine.com 44724 Morley Drive Clinton Township, MI 48036
MATERIAL SPECIFICATIONS:	CUSTOMER:		
PROCESS SPECIFICATIONS:	THIS DRAWING IS SUPPLIED FOR INFORMATION ONLY. DESIGN FEATURES, SPECIFICATIONS AND PERFORMANCE DATA SHOWN HEREON ARE THE PROPERTY OF THE AMPHENOL CORPORATION. NO RIGHTS OF REPRODUCTION ARE IMPLIED. ALL DIMENSIONS ARE SUBJECT TO NORMAL MANUFACTURING VARIATIONS.		ECO-MATE, PLUG, SIZE 12,8POS, SOCKET, END CAP.
NEXT ASSY:	SIZE B C-	TYPE NONE	DWG NO. RT06128S*HEC REVISION B1 SHEET 1 OF 1

TITLE: ECO-MATE, PLUG, SIZE 12,8POS, SOCKET, END CAP. DWG NO.: RT06128S-HEC REV: B1 SH: 1 OF: 1