

SPECIFICATIONS	
CONTACT CARRIER MATERIAL/COLOR	TPU/YELLOW
MOLDED HEAD MATERIAL/COLOR	TPU/YELLOW
CONTACT MATERIAL/PLATING	BRASS/GOLD
COUPLING NUT MATERIAL/PLATING	BRASS/NICKEL
RATED CURRENT [A]	10.0 A
RATED VOLTAGE [V]	600 V
OUTER JACKET MATERIAL/COLOR	PVC/YELLOW
CONDUCTOR INSULATION MATERIAL	PVC
NUMBER OF CONDUCTORS [AWG]	5x16 AWG
TEMPERATURE RATING	-40°C to +105°C (-40°F to +221°F)
PROTECTION CLASS	MEETS NEMA 1,3,4,6P AND IEC IP67

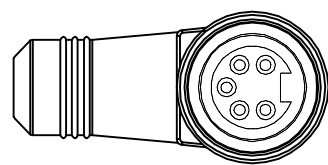
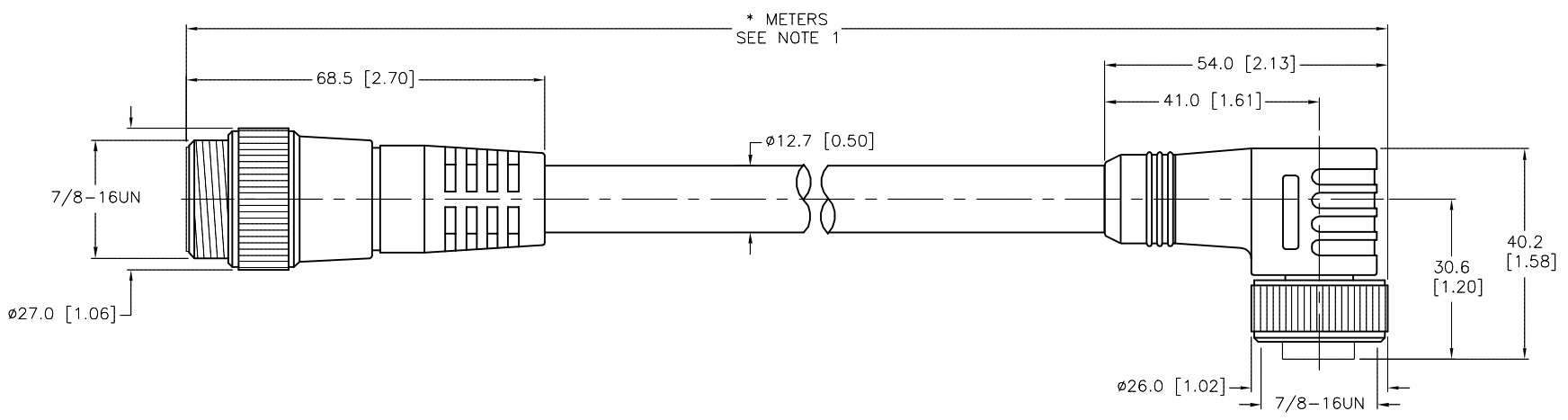

SOURCE DRAWING - FOR REFERENCE ONLY

CABLE LENGTH	TOLERANCE*
ALL LENGTHS	+ 4% (OR 50mm) OF LENGTH - 0% (OR 0mm) OF LENGTH WHICHEVER IS GREATER
STRIP LENGTH	TOLERANCE*
0-7mm	±0.5mm
8-29mm	±1.0mm
30-49mm	±2.0mm
50-69mm	±3.0mm
70-100mm	±4.0mm
OVER 100mm	±5.0mm
* UNLESS OTHERWISE SPECIFIED	

NOTES:
1. "*" INDICATES CABLE LENGTH IN METERS. CONTACT TURCK TO ORDER SPECIFIC LENGTHS.

RELATED DOCUMENTS	3RD ANGLE PROJECTION	THIS DRAWING IS CONFIDENTIAL AND THE PROPERTY OF TURCK INC. USE OF THIS DOCUMENT WITHOUT WRITTEN PERMISSION IS PROHIBITED.		TURCK INC High Technology Sensors and Automation Controls 3000 CAMPUS DRIVE MINNEAPOLIS, MN 55441 1-800-544-7769 (763) 553-7300 (763) 553-0708 fax turck.com	
1.		DRFT	RWC	DATE	02/02/09
2.		APVD		SCALE	1=1.3
3.	ALL DIMENSIONS DISPLAYED ON THIS DRAWING ARE FOR REFERENCE ONLY	UNIT OF MEASUREMENT		DESCRIPTION	
4.		MILLIMETER [INCH]		RSM WKM 56-*M	
MATERIAL	CONTACT TURCK FOR MORE INFORMATION	IDENTIFICATION NO.		REV	
SEE SPECIFICATIONS				D	
FINISH	DO NOT SCALE THIS DRAWING	FILE: 777000433		SHEET 1 OF 1	
SEE SPECIFICATIONS					

D	UPDATE CABLE DIA.	NF	12/15/14	47628
REV	DESCRIPTION	BY	DATE	ECO NO.