

RSF20 Series

Low level switch for boiling water



- **Pivot out of liquid**
- **Low level switch position**
- **Many WRAS (approved for use in hot & cold water) and NSF approved variants**
- **Many variants are UL recognised components File No. E171218**
- **Flying lead or M12 connector**

Technical Specification

Material	Polyphenylene Sulphide (PPS)
Colour	Grey
Temp. Range °C	-10 / +120 *
°F	+14 / +248 *
Minimum liquid SG	0.80
Must close level (SG=1)	125mm
Must open level (SG=1)	85mm

* Maximum temperature requires ETFE cable to be specified.

The RSF20 is designed to eliminate the problems associated with limescale build up around the pivot point on a conventional float switch.

This particular series is primarily for applications where a low level condition has to be monitored, in a system where the liquid is usually maintained at a high level, or where a wider differential is required between the opening and closing levels.

The extended drop float actuator allows the switch housing and float pivots to be located above the surface of the liquid, while the excess buoyancy of the float chamber itself ensures that it floats, even when scale builds up on the float chamber.

Typical applications include wall kettles and hot vending machines.

The switch is closed when the level is low(float down) and opens as the liquid level rises. Version are available with either flying leads or M12 circular connector. Optional plug and cables assemblies are available for use with M12 connection versions.

Electrical Specification

	25W (Y code)	100W (H code)
Contact Form	N/C	N/C
Switching Power Max VA	25	100
Switching Voltage AC Max V	240	300
Switching Voltage DC Max V	120	300
Switching Current Max A	0.6	1

All ratings are for resistive load only.

Standard Parts

Standard Parts	Material	Approvals	Max Power	Leadouts	Gasket
RSF26H050TG	PPS	WRAS, UL & NSF	100VA	50cm ETFE 19/0.2	Viton
RSF26H100RF	PPS	WRAS, UL & NSF	100VA	1 metre PVC 16/0.2	Nitrile
RSF26Y050TG	PPS	WRAS, UL & NSF	25VA	50cm ETFE 19/0.2	Viton
RSF26Y100RF	PPS	WRAS, UL & NSF	25VA	1 metre PVC 16/0.2	Nitrile
RSF26HFP	PPS	WRAS, UL & NSF	100VA	M12 connector	Nitrile
RSF26YFP	PPS	WRAS, UL & NSF	25VA	M12 connector	Nitrile

Custom versions can be made for particular applications. Please contact Cynergy3 with your requirements.

Mechanical Dimensions

All dimensions are in millimetres (inches)

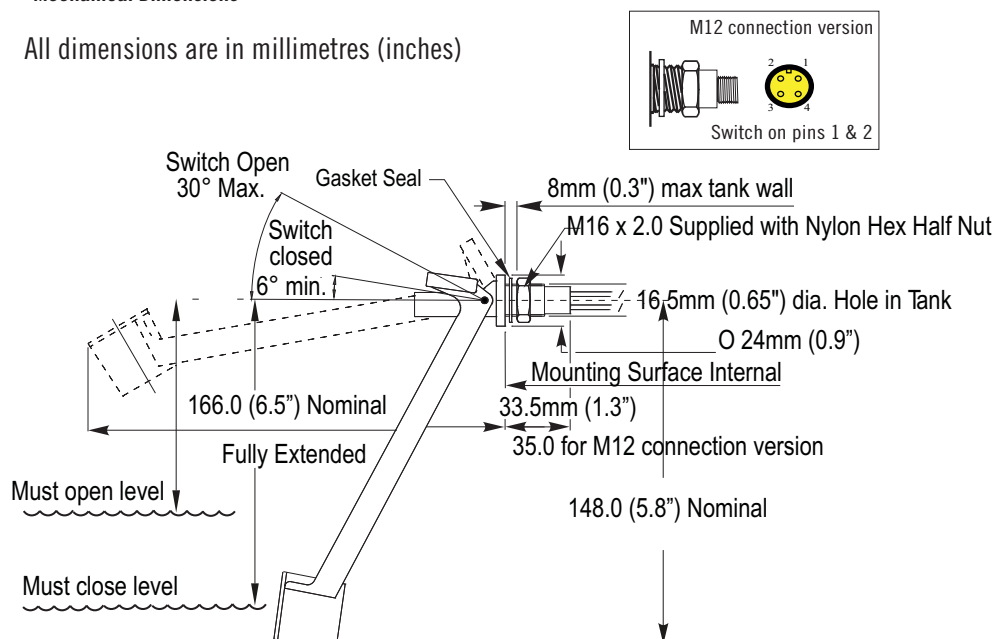

Cynergy3 Components Ltd.
7 Cobham Road
Ferndown Industrial Estate
Wimborne, Dorset BH21 7PE
Telephone +44 (0) 1202 897969
Email:sales@cynergy3.com

ISO9001 CERTIFIED

RSF20 2017



Made in the UK

www.cynergy3.com