



Main

Range of product	Harmony Electromechanical Relays
Series name	Interface relay
Product or component type	Plug-in relay
Device short name	RSB
Contacts type and composition	2 C/O
Contact operation	Standard
[Uc] control circuit voltage	48 V DC
[Ithe] conventional enclosed thermal current	8 A at -40...40 °C
Status LED	Without
Control type	Without push-button

Complementary

Shape of pin	Flat (PCB type)
Average coil resistance	5520 Ohm network: AC at 20 °C +/- 10 %
[Ue] rated operational voltage	33.6...72 V DC
[Ui] rated insulation voltage	400 V conforming to EN/IEC 60947
[Uimp] rated impulse withstand voltage	3.6 kV conforming to IEC 61000-4-5
Contacts material	Silver alloy (AgNi)
[Ie] rated operational current	4 A (AC-1/DC-1) NC conforming to IEC 8 A (AC-1/DC-1) NO conforming to IEC
Minimum switching current	10 mA
Maximum switching voltage	300 V DC conforming to IEC
Minimum switching voltage	12 V
Maximum switching capacity	2000 VA/224 W
Resistive rated load	8 A at 250 V AC 8 A at 28 V DC
Minimum switching capacity	120 mW at 10 mA, 12 V
Operating rate	<= 600 cycles/hour under load <= 18000 cycles/hour no-load
Mechanical durability	30000000 cycles
Electrical durability	100000 Cycles, 8 A at 250 V, AC-1 NO 100000 cycles, 4 A at 250 V, AC-1 NC
Operating time	20 ms operating 20 ms reset
Marking	CE
Average coil consumption	0.45 W DC
Drop-out voltage threshold	>= 0.1 U _c DC
Safety reliability data	B10d = 100000
Protection category	RT I
Test levels	Level A group mounting
Operating position	Any position
Net weight	0.014 kg
Sale per indivisible quantity	10
Device presentation	Complete product

The information provided in this documentation contains general descriptions and/or technical characteristics of the performance of the products contained herein. This documentation is not intended as a substitute for and is not to be used for determining suitability or reliability of these products for specific user applications. It is the duty of any such user or integrator to perform the appropriate and complete risk analysis, evaluation and testing of the products with respect to the relevant specific application or use thereof. Neither Schneider Electric Industries SAS nor any of its affiliates or subsidiaries shall be responsible or liable for misuse of the information contained herein.

Environment

Dielectric strength	1000 V AC between contacts 2500 V AC between poles 5000 V AC between coil and contact
Standards	CSA C22.2 No 14 EN/IEC 61810-1 UL 508
Product certifications	EAC CSA UL
Ambient air temperature for storage	-40...85 °C
Vibration resistance	+/- 1 mm (f= 10...55 Hz) conforming to EN/IEC 60068-2-6
IP degree of protection	IP40 conforming to EN/IEC 60529
Shock resistance	10 gn (duration = 11 ms) for not operating conforming to EN/IEC 60068-2-27 5 gn (duration = 11 ms) for in operation conforming to EN/IEC 60068-2-27
Ambient air temperature for operation	-40...85 °C (DC)

Packing Units

Unit Type of Package 1	PCE
Number of Units in Package 1	1
Package 1 Height	1.7 cm
Package 1 Width	2.5 cm
Package 1 Length	3.1 cm
Package 1 Weight	13 g
Unit Type of Package 2	BB1
Number of Units in Package 2	10
Package 2 Height	1.8 cm
Package 2 Width	2.6 cm
Package 2 Length	31 cm
Package 2 Weight	159 g
Unit Type of Package 3	S01
Number of Units in Package 3	350
Package 3 Height	15 cm
Package 3 Width	15 cm
Package 3 Length	40 cm
Package 3 Weight	5.768 kg

Offer Sustainability

Sustainable offer status	Green Premium product
REACH Regulation	REACH Declaration
EU RoHS Directive	Pro-active compliance (Product out of EU RoHS legal scope) EU RoHS Declaration
Toxic heavy metal free	Yes
Mercury free	Yes
China RoHS Regulation	China RoHS Declaration
RoHS exemption information	Yes
Environmental Disclosure	Product Environmental Profile
WEEE	The product must be disposed on European Union markets following specific waste collection and never end up in rubbish bins

Contractual warranty

Warranty	18 months
----------	-----------

Dimensions

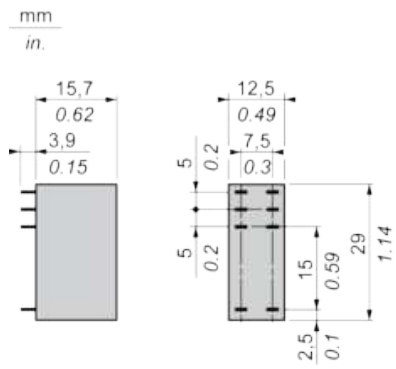

Wiring Diagram

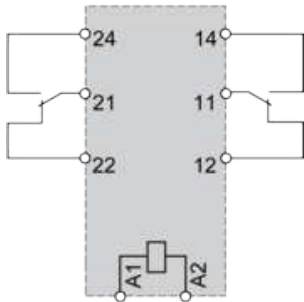
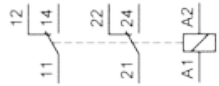

NOTE: For DC input, A1 have to be +, otherwise it would short circuit from protection module

Electrical Durability of Contacts

Durability (inductive load) = durability (resistive load) x reduction coefficient.

Resistive AC load

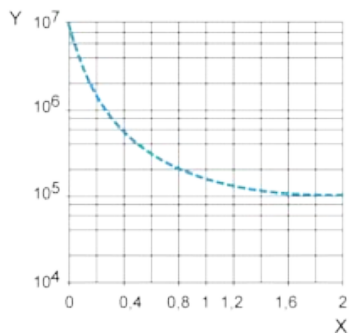

X Switching capacity (kVA)

Y Durability (Number of operating cycles)

Reduction coefficient for inductive AC load (depending on power factor $\cos \phi$)

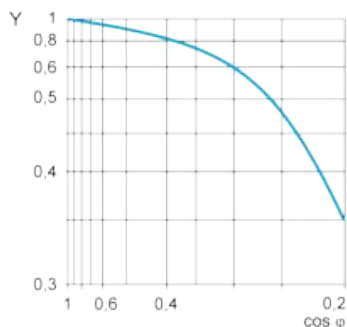

Y Reduction coefficient (A)

Maximum switching capacity on resistive DC load

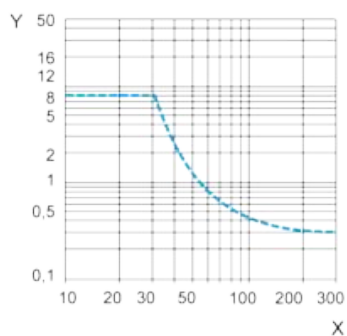

X Voltage DC

Y Current DC

Note : These are typical curves, actual durability depends on load, environment, duty cycle, etc.