

The resistive element comprises a metal oxide film deposited on a ceramic former. The element is protected by a flameproof coating which will withstand overload conditions without flame or mechanical damage. They are recommended for use in applications such as line protection etc

—

Type	Rated Power @ 70°C	Max. Working Voltage	Max. Overload Voltage	Dielectric Withstand Voltage	Resistance Range	Operating Temp. Range	
Normal Size	ROX025	0.25W	250V	400V	250V	0.3 ~ 50K	-55 ~ 155°C
	ROX05	0.5W	250V	400V	250V	0.3 ~ 330K	
	ROX1	1W	350V	600V	350V	0.1 ~ 470K	
	ROX2	2W	350V	600V	350V	0.1 ~ 560K	
	ROX3	3W	500V	800V	500V	5.0 ~ 100K	
	ROX5	5W	750V	1000V	750V	5.0 ~ 150K	
	ROX7	7W	750V	1000V	750V	20 ~ 150K	
	ROX8	8W	750V	1000V	750V	30 ~ 200K	
	ROX9	9W	750V	1000V	750V	50 ~ 200K	
Small Size	ROX05S	0.5W	250V	400V	250V	0.3 ~ 50K	
	ROX1S	1W	350V	600V	350V	0.1 ~ 270K	
	ROX2S	2W	350V	600V	350V	0.1 ~ 470K	
	ROX3S	3W	350V	600V	350V	0.3 ~ 560K	
	ROX4S	4W	500V	800V	500V	5.0 ~ 100K	
	ROX5SS	5W	500V	800V	500V	5.0 ~ 100K	
	ROX5S	5W	500V	800V	500V	5.0 ~ 560K	

Resistors shall have a rated direct-current (DC) continuous working voltage or an approximate sine-wave root-mean-square (RMS) alternating-current (AC) continuous working voltage at commercial line frequency and waveform corresponding to the power rating , as determined from the following formula :

Where : RCWV = Rated DC or RMS AC continuous working voltage at commercial-line frequency and waveform (volt)

P = Power Rating (watt)

R = Nominal Resistance (ohm)

Rated Voltage = RCWV or Max. Working Voltage, whichever is smaller



Characteristics	Specification		Test Methods (JIS C 5201-1)
DC. Resistance	Must be within the specified tolerance		5.1 The limit of error of measuring apparatus shall not exceed allowable range or 5% of resistance tolerance
Temperature Coefficient	Range	TCR (PPM/°C)	5.2 Natural resistance change per temp. degree centigrade. $\frac{R - R}{R (t - t)} \times 10 \text{ (PPM/ } ^\circ\text{)}$ R : Resistance value at room temperature (t) R : Resistance value at room temp. plus 100 (t)
		±200	
		±350	
	101K ~ 1M	-700	
	1.1M ~ 10M	-1500	
Short time overload	Resistance change rate is with no evidence of mechanical damage		5.5 Permanent resistance change after the application of a potential of 2.5 times RCWV or the max. overload voltage respectively specified in the above list, whichever less for 5 seconds
Dielectric Withstanding Voltage	No evidence of flashover mechanical damage, arcing or insulation break down		5.7 Resistors shall be clamped in the trough of a 90° metallic V-block and shall be tested at AC potential respectively specified in the electrical characteristics table for 60 + 10/ -0 seconds
Terminal Strength	No Evidence of mechanical damage		6.1 Resistance to a 2.5 kgs direct load for 10 secs. in the direction of the longitudinal axis of the terminal leads Terminal leads shall be bent through 90° at point of about 6mm from the body of the resistor and shall be rotated through 360° about the original axis of the bent terminal in alternating direction for a total of 3 rotations.
Resistance to soldering heat	Resistance change rate is: evidence of mechanical damage		6.4 Permanent resistance change when leads immersed to 3.2 mm to 4.8 mm from the body in 350 ± 10 solder for 3 ± 0.5 seconds
Solderability	95 % coverage Min.		6.5 The area covered with a new , smooth, clean , shiny and continuous surface free from concentrated pinholes. Test temp. of solder: 245 ± 3 Dwell time in solder : 2 ~ 3 seconds



Characteristics	Specification	Test Methods (JIS C 5201-1)		
Resistance to Solvent	No deterioration of protective coatings and marking	6.9 Specimens shall be immersed in a bath of trichroethane completely for 3 minutes with ultrasonic		
Temperature cycling	Resistance change rate is: with no evidence of mechanical damage	7.4 Resistance change after continuous 5 cycles for duty shown below:		
		1	1	1
		2	2	2
		3		

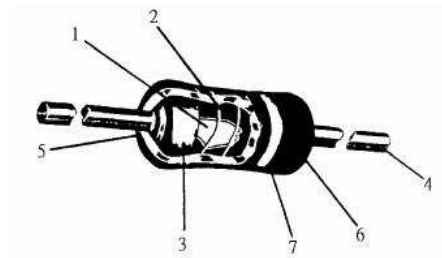

1	Basic Body	Rod Type Ceramics
2	Resistance Film	
3	End Cap	Steel (Tin plated iron surface)
4	Lead Wire	Annealed copper wire coated with tin
5	Joint	By welding
6	Coating	Normal size: --Insulated & Non-Flame Paint (Color : Gray) Small size: --Insulated & Non-Flame Paint (Color : Sea-Blue)
7	Color Code	Non-Flame epoxy resin

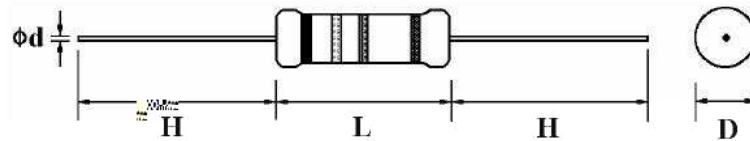

	ROX025	2.5	7.5	0.54	28
	ROX05	3.5	10	0.54	28
	ROX1	5	12	0.70	25
	ROX2	5.5	16	0.70	28
	ROX3	6.5	17.5	0.75	28
	ROX5	8.5	26	0.75	38
	ROX7	8.5	32	0.75	38
	ROX8	8.5	41	0.75	38
	ROX9	8.5	54	0.75	38
	ROX05S	2.5	7.5	0.54	28
	ROX1S	3.5	10	0.54	28
	ROX2S	5	12	0.70	25
	ROX3S	5.5	16	0.70	28
	ROX4S	6.5	17.5	0.75	28
	ROX5SS	6.5	17.5	0.75	28
	ROX5S	8	25	0.75	38



Welding point, terminal and lead wire, is permissible to be exposed without the outer coated cover. The extent should be within 1/2 of the resistor body diameter

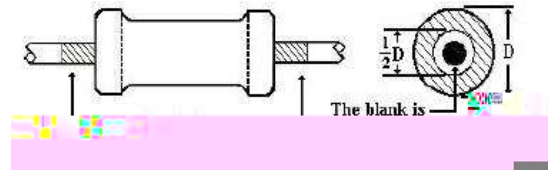

For 1/4W, 1/2W, 1W, 2W, 3W, 4W, 5W and all of small size Resistors shall be marked with color coding. colors shall be in accordance with JIS C 0802

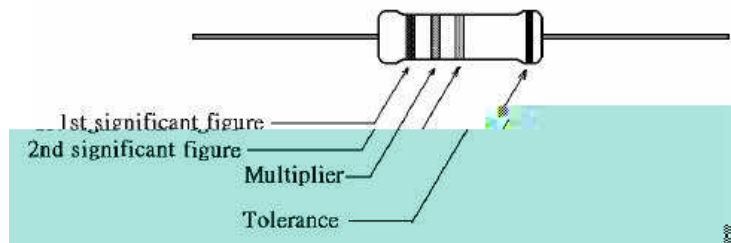

For 7W, 8W, 9W marking shall be in text format:

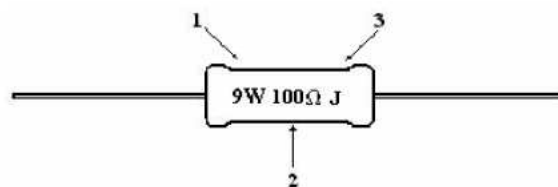

Code description and regulation

1. Wattage rating.
2. Nominal resistance value.
3. Resistance Tolerance.

G: ± 2 %

J: ± 5 %

K: ± 10 %



Taping:

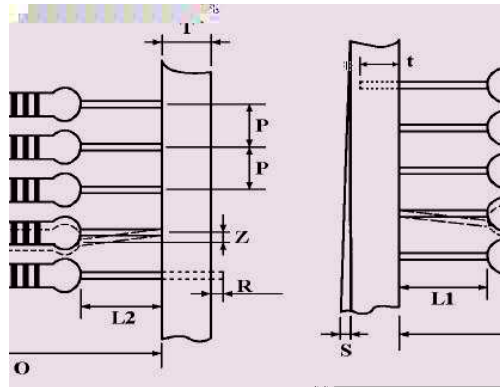

	Type	Style	O±1	P	L1-L2	T	Z	R	t	S
Normal Size	ROX025	PT-52	52	5±0.3	1 Max	6±1	1 Max	0	4±1	0.5 max
	ROX05	PT-52	52	5±0.3	1 Max	6±1	1 Max	0	4±1	0.5 max
	ROX1	PT-52	52	5±0.3	1 Max	6±1	1 Max	0	4±1	0.5 max
	ROX2	PT-64	64	10±0.5	1 Max	6±1	1 Max	0	5±1	0.5 max
	ROX3	PT-64	64	10±0.5	1 Max	6±1	1 Max	0	5±1	0.5 max
Small Size	ROX05S	PT-52	52	5±0.3	1 Max	6±1	1 Max	0	4±1	0.5 max
	ROX1S	PT-52	52	5±0.3	1 Max	6±1	1 Max	0	4±1	0.5 max
	ROX2S	PT-52	52	5±0.3	1 Max	6±1	1 Max	0	4±1	0.5 max
	ROX3S	PT-64	64	10±0.5	1 Max	6±1	1 Max	0	5±1	0.5 max
	ROX4S	PT-64	64	10±0.5	1 Max	6±1	1 Max	0	5±1	0.5 max
	ROX5SS	PT-64	64	10±0.5	1 Max	6±1	1 Max	0	5±1	0.5 max

Tape in box packing (Ammopack):

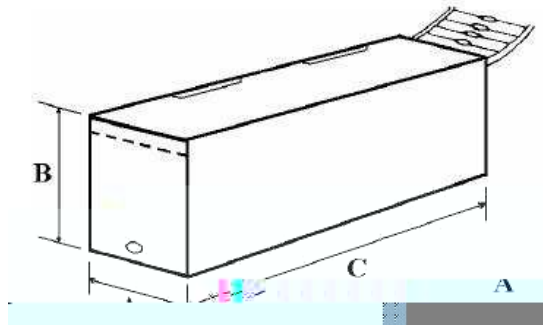

Type	C ± 5	A ± 5	B ± 5	Pack Quantity
ROX025	250	75	96	5000
ROX05	260	85	70	1000
ROX1	262	86	80	1000
ROX2	262	92	108	1000
ROX3	256	92	80	500
ROX05S	250	75	96	5000
ROX1S	260	85	70	1000
ROX2S	262	86	80	1000
ROX3S	262	92	108	1000
ROX4S	256	92	80	500
ROX5SS	256	92	80	500

NB Certain products can be supplied reeled on request.



Plastic cases in box:

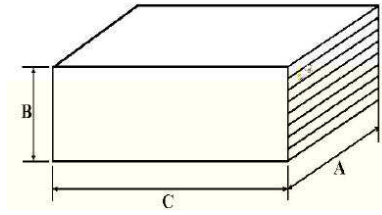

Type	C ±5	A ±5	B ±5	Quantity	
				Plastic Case	Box
ROX5S	36	20	8	100	1000
ROX5	36	20	8	100	1000

Bulk packaging (plastic bag in inner box):

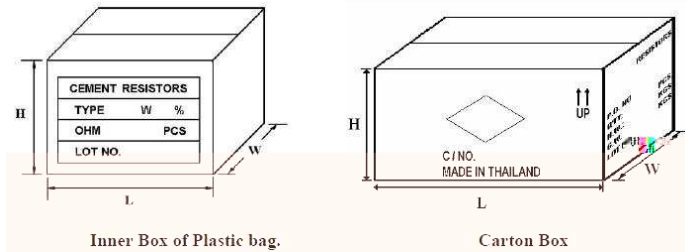

Type	Qty/Bag (Pcs)	Qty/Box (Pcs)	Qty/Carton Pcs	Box size LxWxH (±5)	Carton size LxWxH (±5)	Gross wt ±2 Kgs
ROX7	8	32	1600	150 x 75 x 33	432 x 308 x 215	9.5
ROX8	8	32	1600	150 x 75 x 33	432 x 308 x 215	11.5
ROX9	10	300	1800	200 x 171 x 113	520 x 215 x 250	15

ROX	1S	J	100K		
ROX Flame proof power metal oxide film resistor	025 - 1/4W 05 1/2W 1 1W 2 2W 3 3W 5 5W 7 7W 8 8W 9 9W	05S 1/2W 1S 1W 2S 2W 3S 3W 4S 4W 5SS 5W 5S 5W	G 2% J 5%	R33 -0.33 1R0 - 1 10R - 10 100R - 100 1K0 1K (1000) 100K 100K	BL * Pre-formed Leads TR - Reeled