

RM48L952 16- and 32-Bit RISC Flash Microcontroller

1 Device Overview

1.1 Features

- High-Performance Microcontroller for Safety-Critical Applications
 - Dual CPUs Running in Lockstep
 - ECC on Flash and RAM Interfaces
 - Built-In Self-Test (BIST) for CPU and On-chip RAMs
 - Error Signaling Module With Error Pin
 - Voltage and Clock Monitoring
- ARM® Cortex®-R4F 32-Bit RISC CPU
 - Efficient 1.66 DMIPS/MHz With 8-Stage Pipeline
 - FPU With Single- and Double-Precision
 - 12-Region Memory Protection Unit (MPU)
 - Open Architecture With Third-Party Support
- Operating Conditions
 - System Clock up to 220 MHz
 - Core Supply Voltage (VCC): 1.2 V Nominal
 - I/O Supply Voltage (VCCIO): 3.3 V Nominal
 - ADC Supply Voltage (V_{CCAD}): 3.0 to 5.25 V
- Integrated Memory
 - 3MB of Program Flash With ECC
 - 256KB of RAM With ECC
 - 64KB of Flash With ECC for Emulated EEPROM
- 16-Bit External Memory Interface
- Common Platform Architecture
 - Consistent Memory Map Across Family
 - Real-Time Interrupt (RTI) Timer OS Timer
 - 96-Channel Vectored Interrupt Module (VIM)
 - 2-Channel Cyclic Redundancy Checker (CRC)
- Direct Memory Access (DMA) Controller
 - 16 Channels and 32 Control Packets
 - Parity Protection for Control Packet RAM
 - DMA Accesses Protected by Dedicated MPU
- Frequency-Modulated Phase-Locked Loop (FMPLL) With Built-In Slip Detector
- Separate Nonmodulating PLL
- Trace and Calibration Capabilities
 - Embedded Trace Macrocell (ETM-R4)
 - Data Modification Module (DMM)
 - RAM Trace Port (RTP)
 - Parameter Overlay Module (POM)
- Multiple Communication Interfaces
 - 10/100 Mbps Ethernet MAC (EMAC)
 - IEEE 802.3 Compliant (3.3-V I/O Only)
 - Supports MII, RMII, and MDIO
 - USB
 - 2-Port USB Host Controller
 - One Full-Speed USB Device Port
 - Three CAN Controllers (DCANs)
 - 64 Mailboxes, Each With Parity Protection
 - Compliant to CAN Protocol Version 2.0B
 - Standard Serial Communication Interface (SCI)
 - Local Interconnect Network (LIN) Interface Controller
 - Compliant to LIN Protocol Version 2.1
 - Can be Configured as a Second SCI
 - Inter-Integrated Circuit (I²C)
 - Three Multibuffered Serial Peripheral Interfaces (MibSPIs)
 - 128 Words With Parity Protection Each
 - Two Standard Serial Peripheral Interfaces (SPIs)
- Two Next Generation High-End Timer (N2HET) Modules
 - N2HET1: 32 Programmable Channels
 - N2HET2: 18 Programmable Channels
 - 160-Word Instruction RAM Each With Parity Protection
 - Each N2HET Includes Hardware Angle Generator
 - Dedicated High-End Transfer Unit (HTU) With MPU for Each N2HET
- Two 12-Bit Multibuffered ADC Modules
 - ADC1: 24 Channels
 - ADC2: 16 Channels Shared With ADC1
 - 64 Result Buffers With Parity Protection Each
- General-Purpose Input/Output (GPIO) Pins Capable of Generating Interrupts
 - Sixteen Pins on the ZWT Package
 - Ten Pins on the PGE Package
- IEEE 1149.1 JTAG, Boundary Scan and ARM CoreSight™ Components
- JTAG Security Module
- Packages
 - 144-Pin Quad Flatpack (PGE) [Green]
 - 337-Ball Grid Array (ZWT) [Green]



1.2 Applications

- Industrial Safety Applications
 - Industrial Automation
 - Safe Programmable Logic Controllers (PLCs)
 - Power Generation and Distribution
 - Turbines and Windmills
 - Elevators and Escalators
- Medical Applications
 - Ventilators
 - Defibrillators
 - Infusion and Insulin Pumps
 - Radiation Therapy
 - Robotic Surgery

1.3 Description

The RM48L952 device is a high-performance microcontroller family for safety systems. The safety architecture includes dual CPUs in lockstep, CPU and memory BIST logic, ECC on both the flash and the data SRAM, parity on peripheral memories, and loopback capability on peripheral I/Os.

The RM48L952 device integrates the ARM Cortex-R4F Floating-Point CPU. The CPU offers an efficient 1.66 DMIPS/MHz, and has configurations that can run up to 220 MHz, providing up to 365 DMIPS. The device supports the little-endian [LE] format.

The RM48L952 device has 3MB of integrated flash and 256KB of data RAM. Both the flash and RAM have single-bit error correction and double-bit error detection. The flash memory on this device is a nonvolatile, electrically erasable, and programmable memory implemented with a 64-bit-wide data bus interface. The flash operates on a 3.3-V supply input (same level as I/O supply) for all read, program, and erase operations. When in pipeline mode, the flash operates with a system clock frequency of up to 220 MHz. The SRAM supports single-cycle read and write accesses in byte, halfword, word, and double-word modes.

The RM48L952 device features peripherals for real-time control-based applications, including two Next Generation High-End Timer (N2HET) timing coprocessors and two 12-bit Analog-to-Digital Converters (ADCs) supporting up to 24 inputs.

The N2HET is an advanced intelligent timer that provides sophisticated timing functions for real-time applications. The timer is software-controlled, using a reduced instruction set, with a specialized timer micromachine and an attached I/O port. The N2HET can be used for pulse-width-modulated outputs, capture or compare inputs, or GPIO. The N2HET is especially well suited for applications requiring multiple sensor information and drive actuators with complex and accurate time pulses. A High-End Timer Transfer Unit (HTU) can perform DMA-type transactions to transfer N2HET data to or from main memory. A Memory Protection Unit (MPU) is built into the HTU.

The device has two 12-bit-resolution MibADCs with 24 channels and 64 words of parity-protected buffer RAM each. The MibADC channels can be converted individually or can be grouped by software for sequential conversion sequences. Sixteen channels are shared between the two MibADCs. There are three separate groupings. Each sequence can be converted once when triggered or configured for continuous conversion mode. The MibADC has a 10-bit mode for use when compatibility with older devices or faster conversion time is desired.

The device has multiple communication interfaces: three MibSPIs, two SPIs, one LIN, one SCI, three DCANs, one I2C module, one Ethernet, and one USB module. The SPIs provide a convenient method of serial high-speed communication between similar shift-register type devices. The LIN supports the Local Interconnect standard 2.0 and can be used as a UART in full-duplex mode using the standard Non-Return-to-Zero (NRZ) format.

The DCAN supports the CAN 2.0 (A and B) protocol standard and uses a serial, multimaster communication protocol that efficiently supports distributed real-time control with robust communication rates of up to 1 Mbps. The DCAN is ideal for systems operating in noisy and harsh environments (for example, automotive vehicle networking and industrial fieldbus) that require reliable serial communication or multiplexed wiring.

The Ethernet module supports MII, RMII, and MDIO interfaces.

The USB module includes a 2-port USB host controller. It is revision 2.0-compatible, based on the OHCI specification for USB, release 1.0. The USB module also includes a USB device controller compatible with the USB specification revision 2.0 and USB specification revision 1.1.

The I2C module is a multimaster communication module providing an interface between the microcontroller and an I²C-compatible device through the I²C serial bus. The I²C supports speeds of 100 and 400 Kbps.

The Frequency-Modulated Phase-Locked Loop (FMPLL) clock module is used to multiply the external frequency reference to a higher frequency for internal use. There are two FMPLL modules on this device. These modules, when enabled, provide two of the seven possible clock source inputs to the Global Clock Module (GCM). The GCM manages the mapping between the available clock sources and the device clock domains.

The device also has an External Clock Prescaler (ECP) module that when enabled, outputs a continuous external clock on the ECLK pin (or ball). The ECLK frequency is a user-programmable ratio of the peripheral interface clock (VCLK) frequency. This low-frequency output can be monitored externally as an indicator of the device operating frequency.

The DMA controller has 16 channels, 32 control packets, and parity protection on its memory. An MPU is built into the DMA to limit the DMA to prescribed areas of memory and to protect the rest of the memory system from any malfunction of the DMA.

The Error Signaling Module (ESM) monitors all device errors and determines whether an interrupt is generated or the external `ERROR` pin is toggled when a fault is detected. The `ERROR` pin can be monitored externally as an indicator of a fault condition in the microcontroller.

The External Memory Interface (EMIF) provides off-chip expansion capability with the ability to interface to synchronous DRAM (SDRAM) devices, asynchronous memories, peripherals or FPGA devices.

Several interfaces are implemented to enhance the debugging capabilities of application code. In addition to the built-in ARM Cortex-R4F CoreSight debug features, an External Trace Macrocell (ETM) provides instruction and data trace of program execution. For instrumentation purposes, a RAM Trace Port (RTP) module is implemented to support high-speed tracing of RAM and peripheral accesses by the CPU or any other master. A Data Modification Module (DMM) gives the ability to write external data into the device memory. Both the RTP and DMM have no or only minimum impact on the program execution time of the application code. A Parameter Overlay Module (POM) can reroute flash accesses to internal memory or to the EMIF. This rerouting allows the dynamic calibration against production code of parameters and tables without rebuilding the code to explicitly access RAM or halting the processor to reprogram the data flash.

With integrated safety features and a wide choice of communication and control peripherals, the RM48L952 device is an ideal solution for high-performance real-time control applications with safety-critical requirements.

Device Information⁽¹⁾

PART NUMBER	PACKAGE	BODY SIZE
RM48L952ZWT	NFBGA (337)	16.0 mm × 16.0 mm
RM48L952PGE	LQFP (144)	20.0 mm × 20.0 mm

(1) For more information, see [Section 9, Mechanical Packaging and Orderable Information](#).

1.4 Functional Block Diagram

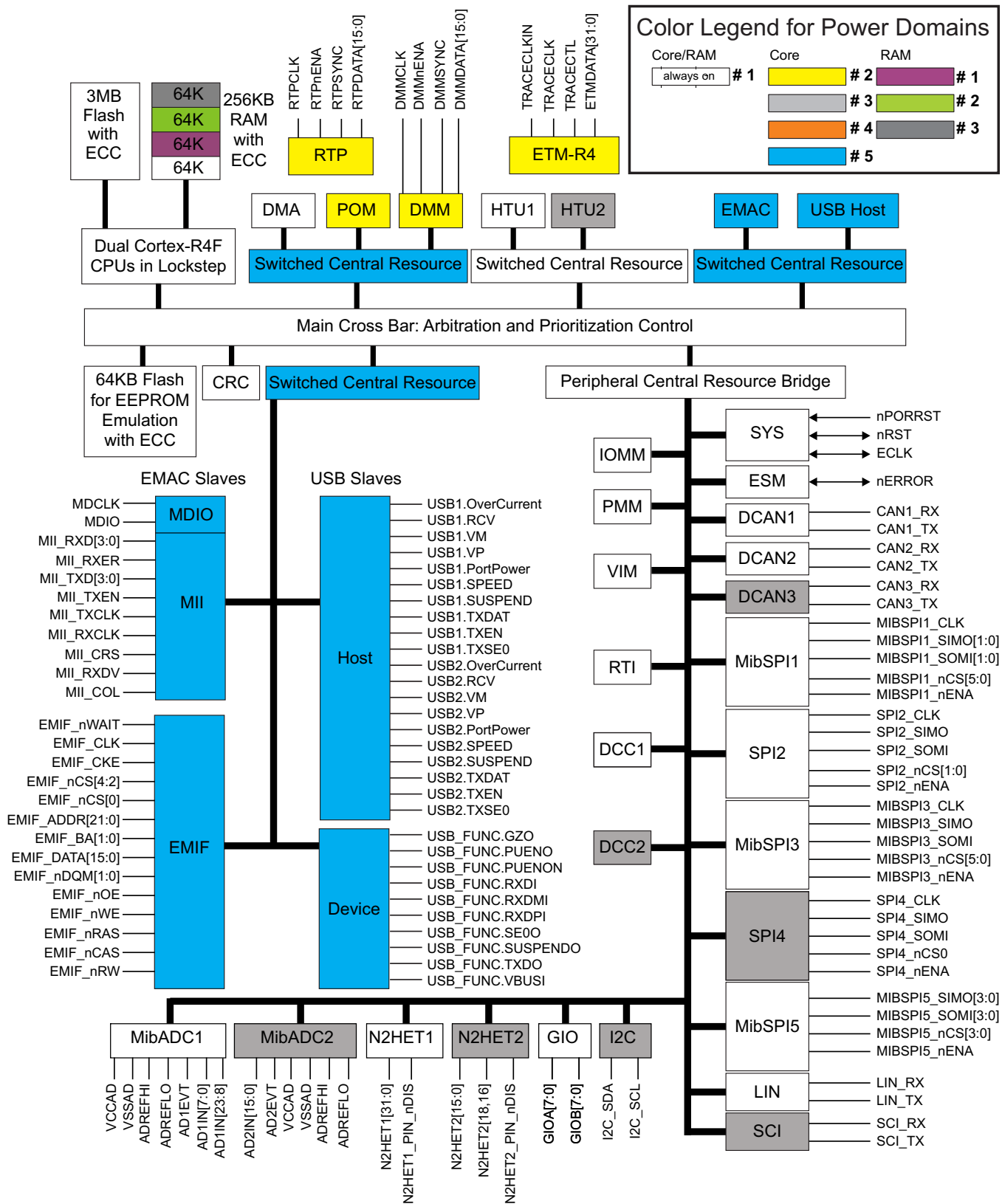

Figure 1-1. Functional Block Diagram

Table of Contents

1	Device Overview	1	6.12	Parity Protection for Peripheral RAMs	86
1.1	Features	1	6.13	On-Chip SRAM Initialization and Testing	88
1.2	Applications	2	6.14	External Memory Interface (EMIF)	90
1.3	Description	3	6.15	Vectored Interrupt Manager	97
1.4	Functional Block Diagram	5	6.16	DMA Controller	100
2	Revision History	7	6.17	Real Time Interrupt Module	103
3	Device Comparison	10	6.18	Error Signaling Module	105
4	Terminal Configuration and Functions	12	6.19	Reset / Abort / Error Sources	109
4.1	PGE QFP Package Pinout (144-Pin)	12	6.20	Digital Windowed Watchdog	111
4.2	ZWT BGA Package Ball-Map (337-Ball Grid Array)	13	6.21	Debug Subsystem	112
4.3	Terminal Functions	14	7	Peripheral Information and Electrical Specifications	123
5	Specifications	47	7.1	Peripheral Legend	123
5.1	Absolute Maximum Ratings	47	7.2	Multibuffered 12-Bit Analog-to-Digital Converter	123
5.2	ESD Ratings	47	7.3	General-Purpose Input/Output	134
5.3	Power-On Hours (POH)	47	7.4	Enhanced High-End Timer (N2HET)	135
5.4	Recommended Operating Conditions	48	7.5	Controller Area Network (DCAN)	140
5.5	Switching Characteristics for Clock Domains	49	7.6	Local Interconnect Network Interface (LIN)	141
5.6	Wait States Required	49	7.7	Serial Communication Interface (SCI)	142
5.7	Power Consumption	50	7.8	Inter-Integrated Circuit (I2C)	143
5.8	Input/Output Electrical Characteristics	51	7.9	Multibuffered / Standard Serial Peripheral Interface	146
5.9	Thermal Resistance Characteristics	52	7.10	Ethernet Media Access Controller	158
5.10	Output Buffer Drive Strengths	53	7.11	Universal Serial Bus (USB) Host and Device Controllers	162
5.11	Input Timings	54	8	Device and Documentation Support	164
5.12	Output Timings	54	8.1	Device Support	164
5.13	Low-EMI Output Buffers	56	8.2	Documentation Support	166
6	System Information and Electrical Specifications	58	8.3	Community Resources	166
6.1	Device Power Domains	58	8.4	Trademarks	166
6.2	Voltage Monitor Characteristics	59	8.5	Electrostatic Discharge Caution	166
6.3	Power Sequencing and Power On Reset	60	8.6	Glossary	166
6.4	Warm Reset (nRST)	62	8.7	Device Identification Code Register	167
6.5	ARM-R4F CPU Information	63	8.8	Die Identification Registers	168
6.6	Clocks	66	8.9	Module Certifications	169
6.7	Clock Monitoring	74	9	Mechanical Packaging and Orderable Information	174
6.8	Glitch Filters	76	9.1	Packaging Information	174
6.9	Device Memory Map	77			
6.10	Flash Memory	83			
6.11	Tightly Coupled RAM (TCRAM) Interface Module	86			

2 Revision History

This data manual revision history highlights the technical changes made to the SPNS177B device-specific data manual to make it an SPNS177C revision.

Scope: Applicable updates to the Hercules™ RM MCU device family, specifically relating to the RM48L952 devices, which are now in the production data (PD) stage of development have been incorporated.

Changes from August 1, 2013 to April 30, 2015 (from B Revision (July 2013) to C Revision)	Page
• Section 1 (Device Overview): Updated/Changed section title	1
• Updated/Changed the N2HET feature	1
• (Device Information): Added table	4
• Added Section 3 , Device Comparison	10
• Section 4 (Terminal Configuration and Functions): Updated/Changed section title	12
• Table 4-2 (PGE Enhanced High-End Timer Modules (N2HET1, N2HET2)): Updated/Changed N2HET1 time input capture or output compare pin description	16
• Table 4-2 : Added N2HET1_PIN_nDIS signal DESCRIPTION	16
• Table 4-2 : Updated/Changed N2HET2 time input capture or output compare pin description	17
• Table 4-2 : Added N2HET2_PIN_nDIS signal DESCRIPTION	17
• Table 4-3 Added table note describing limits on pin 55 when configured as GIOB[2]	17
• Section 4.3.1.11 (USB Host and Device Port Controller Interface): Updated/Changed "USB Host Port Controller Interface" title to "USB Host and Device Port Controller Interface"	21
• Section 4.3.1.11 , Added lead-in paragraph for Root Hub Port 0/1 explanation	21
• Table 4-13 (PGE USB Host Port Controller Interface (USB1, USB2)): Updated/Changed the Description for the USB Host Port Controller pins; adding clarity	21
• Table 4-13 : Added Description for the USB1.OVERCURRENT pin	21
• Table 4-13 : Added pin Description for the USB1.PORTPOWER	21
• Table 4-13 : Updated/Changed pin Description for the USB1.SPEED	21
• Table 4-13 : Added pin Description for the USB1.SUSPEND	21
• Table 4-13 : Added pin Description for the USB1.TXDAT	21
• Table 4-13 : Added "Active low output" to the pin Description for the USB1.TXEN	21
• Table 4-13 : Updated/Changed pin Description for the USB1.TXSE0	21
• Table 4-13 : Added pin Description for the USB2.OVERCURRENT	21
• Table 4-13 : Added pin Description for the USB2.RCV	21
• Table 4-13 : Added pin Description for the USB2.PORTPOWER	22
• Table 4-13 : Updated/Changed pin Description for the USB2.SPEED	22
• Table 4-13 : Updated/Changed the pin Description for the USB2.SUSPEND	22
• Table 4-13 : Updated/Changed pin Description for the USB2.TXDAT	22
• Table 4-13 : Added "Active low output" to the pin Description for the USB2.TXEN	22
• Table 4-13 : Updated/Changed pin Description for the USB2.TXSE0	22
• Table 4-14 (PGE USB Device Port Controller Interface (USB_FUNC)): Updated/Changed the Description for the USB Device Port Controller pins; adding clarity	22
• Table 4-14 Added missing USB_FUNC.GZO pin description	22
• Table 4-14 : Added "Active-low output" to the pin Description for the USB2.USB_FUNC.GZO	22
• Table 4-14 : Updated/Changed USB_FUNC.RXDI pin description	22
• Table 4-14 : Updated/Changed USB_FUNC.SUSPENDO pin description	22
• Table 4-14 : Updated/Changed USB_FUNC.VBUSI pin description	22
• Table 4-17 (PGE Test and Debug Modules Interface): Updated/Changed TEST pin description	23
• Table 4-23 (ZWT Enhanced High-End Timer (N2HET) Modules): Updated/Changed N2HET1 time input capture or output compare pin description	27
• Table 4-23 Added alternate terminals for N2HET1 pins 17, 19, 21, 23, 25, 27, 29 and 31	27
• Table 4-23 : Added N2HET1_PIN_nDIS signal DESCRIPTION	27
• Table 4-23 : Updated/Changed N2HET2 time input capture or output compare pin description	28
• Table 4-23 : Added N2HET2_PIN_nDIS signal DESCRIPTION	28
• Table 4-24 Updated description about using GIOB[2] on ball V10	29
• Table 4-32 : Added "receive" to the RMII_CRSDV pin Description	33
• Table 4-32 : Added "receive" to the MII_CRSDV pin Description	33
• Section 4.3.2.11 (USB Host and Device Port Controller Interface): Updated/Changed "USB Host Port Controller	33

- Interface" title to "USB Host and Device Port Controller Interface" 34
- [Section 4.3.2.11](#), Added lead-in paragraph for Root Hub Port 0/1 34
- [Table 4-34](#) (ZWT USB Host Port Controller Interface (USB1, USB2)): Updated/Changed the Description for the USB pins; adding clarity 34
- [Table 4-34](#): Added pin Description for the USB1.OVERCURRENT 34
- [Table 4-34](#): Updated/Changed pin Description for the USB1.RCV 34
- [Table 4-34](#): Added pin Description for the USB1.PORTPOWER 34
- [Table 4-34](#): Updated/Changed pin Description for the USB1.SPEED 34
- [Table 4-34](#): Added pin Description for the USB1.SUSPEND..... 34
- [Table 4-34](#): Added pin Description for the USB1.TXDAT 34
- [Table 4-34](#): Added "Active-low output" to the pin Description for the USB1.TXEN 34
- [Table 4-34](#): Updated/Changed pin Description for the USB1.TXSE0 34
- [Table 4-34](#): Added pin Description for the USB2.OVERCURRENT 34
- [Table 4-34](#): Added pin Description for the USB2.RCV 34
- [Table 4-34](#): Added pin Description for the USB2.PORTPOWER 35
- [Table 4-34](#): Updated/Changed pin Description for the USB2.SPEED 35
- [Table 4-34](#): Added pin Description for the USB2.SUSPEND..... 35
- [Table 4-34](#): Updated/Changed pin Description for the USB2.TXDAT..... 35
- [Table 4-34](#): Added "Active low output" to the pin Description for the USB2.TXEN..... 35
- [Table 4-34](#): Updated/Changed pin Description for the USB2.TXSE0 35
- [Table 4-35](#): Updated/Changed the Description for the USB Device Port Controller pins; adding clarity 35
- Added missing USB_FUNC.GZO pin description to [Table 4-35](#), *ZWT USB Device Port Controller Interface*..... 35
- [Table 4-35](#): Updated/Changed USB_FUNC.RXDI pin description..... 35
- [Table 4-34](#): Added "Active-high output" to the pin Description for the USB_FUNC.SE00 35
- [Table 4-35](#): Updated/Changed USB_FUNC.SUSPENDO pin description 35
- [Table 4-35](#): Updated/Changed USB_FUNC.VBUSI pin description 35
- [Table 4-36](#) (External Memory Interface (EMIF)): Global: Deleted EMIF_RNW pin function..... 36
- [Table 4-42](#) (ZWT Test and Debug Modules Interface): Updated/Changed TEST pin description 42
- [Table 4-44](#) Changed six BGA balls from NC to Reserved 42
- [Section 5](#) (Specifications): Updated/Changed section title 47
- [Section 5.1](#) (Absolute Maximum Ratings): Reformatted table..... 47
- [Section 5.1](#) (Absolute Maximum Ratings): Updated/Changed V_{CCAD} supply voltage range MAX value from "5.5" to "6.25" V 47
- [Section 5.1](#): Updated/Changed ADC input pins input voltage range MAX value from "5.5" to "6.25" V 47
- [Section 5.2](#) (ESD Ratings): Added table (new)..... 47
- [Section 5.3](#) (Power-On Hours (POH)): Added table (new) 47
- [Section 5.8](#) (Input/Output Electrical Characteristics): Updated/Changed Input Clamp Current from I_{IC} to I_{IK}..... 51
- [Section 5.9](#) (Thermal Resistance Characteristics): Moved section and updated/changed subsection title. 52
- [Table 5-2](#) (Thermal Resistance Characteristics (PGE Package)): Added test conditions and added Ψ_{JT} row for PGE package 52
- [Table 5-3](#) (Thermal Resistance Characteristics (ZWT Package)): Added test conditions and added Ψ_{JT} row for ZWT package 52
- Clarified impact of SPI2PC9 register on drive strength of SPI2SOMI pin 53
- Updated/Changed the MIN value of t_{V(RST)} to 2256t_{C(OSC)} ns 62
- [Section 6.6.1](#) (Clock Sources): Added [Table 6-8](#), Available Clock Source cross-references 66
- [Section 6.6.1.1](#) (Main Oscillator): Added [Figure 6-4](#), Recommended Crystal/Clock Connection cross-reference 66
- [Table 6-10](#) Added limits for HF LPO after software trim 68
- [Table 6-13](#) (Clock Domain Descriptions): Added missing "1" to the VCLKACON clock source selection register name for VCLKA3 row 71
- [Table 6-20](#) Corrected size of bank 7 OTP and bank 7 OTP ECC 78
- [Figure 6-10](#) (TCRAM Block Diagram): Updated/Changed figure, deleted A TCM..... 86
- [Table 6-25](#) Added table footnotes identifying the address ranges of the ESRAM PBIST groups 88
- [Table 6-25](#) Added RAM power domain information in the table notes 88
- [Table 6-26](#)(Memory Initialization): Updated/Changed N2HET2 RAM ending address from "0xFF57FFFF" to "0xFF45FFFF" 89
- [Table 6-38](#) Corrected base JTAG ID Base Value From 0xD8A002F to 0xB8A002F 113
- [Table 6-38](#) (JTAG ID Code): Added JTAG Identification Code for Silicon Revision "Rev D" 113
- [Table 7-7](#) (MibADC Recommended Operating Conditions): Updated/Changed Analog input clamp current from I_{AIC} to I_{AIK} 128
- Controller Area Network (DCAN) [Section 7.5.1](#) (Features): Updated/Changed TRM references to the correct

document titles	140
• Table 7-22 (SPI Master Mode External Timing Parameters (CLOCK PHASE = 0, SPICLK = output, SPISIMO = output, and SPISOMI = input)): Updated/Changed table footnote to "... CLOCK PHASE bit (SPIFMTx.16) is cleared"	150
• Section 7.10.1 (Ethernet MII Electrical and Timing Specifications): Updated/Changed the MII parameter names and parametric descriptions for this section.....	158
• Section 7.10.2 (Ethernet RMII Electrical and Timing Specifications): Updated/Changed section title for clarification.....	160
• Section 7.10.2 Updated/Changed the RMII parameter names and parametric descriptions for this section.....	160
• Section 7.10.3 (Management Data Input/Output (MDIO) Electrical and Timing Specifications): Updated/Changed section title for clarification	161
• Table 7-30 (Timing Requirements for MDIO Input): Updated/Changed table title and formatting for clarification	161
• Section 7.11 (Universal Serial Bus (USB) Host and Device Controllers): Updated/Changed section title.....	162
• Table 7-32 (Full-Speed USB Interface Timing Requirements): Updated/Changed the USB signal names to match the terminal functions tables, for all packages.....	162
• Table 7-33 (Full-Speed USB Interface Switching Characteristics): Updated/Changed the USB signal names to match the terminal functions tables, for all packages.....	162
• Section 8 (Device and Documentation Support): Updated/Changed section to meet new requirements, including addition of several subsections	164
• Section 8.7 (Device Identification Code Register): Added Device ID code value for silicon Rev D	167
• Section 8.8 (Die Identification Registers): Updated/Changed the address of the two die identification registers (DIEIDL and DIEIDH) to point to the original registers at location 0xFFFFF7C and 0xFFFFF80 for this section.	168
• Table 8-2 (Die-ID Registers): Updated/Changed the BIT LOCATION column for all ITEM rows	168
• Section 9 (Mechanical Packaging and Orderable Information): Updated/Changed section title	174
• Section 9.1 (Packaging Information): Updated/Changed the paragraph	174

3 Device Comparison

lists the features of the devices.

Table 3-1. RM48L952 Device Comparison⁽¹⁾⁽²⁾

FEATURES	DEVICES							
	RM57L843ZWT⁽³⁾	RM48L952ZWT⁽³⁾	RM48L952PGE	RM48L950ZWT	RM48L750ZWT	RM48L550ZWT	RM46L852ZWT⁽³⁾	RM44L922ZWT
Generic Part Number								
Package	337 BGA	337 BGA	144 QFP	337 BGA	337 BGA	337 BGA	337 BGA	337 BGA
CPU	ARM Cortex-R5F	ARM Cortex-R4F	ARM Cortex-R4F	ARM Cortex-R4F	ARM Cortex-R4F	ARM Cortex-R4F	ARM Cortex-R4F	ARM Cortex-R4F
Frequency (MHz)	333	220	220	200	200	200	220	220
Cache (KB)	32 I 32 D	–	–	–	–	–	–	–
Flash (KB)	4096	3072	3072	3072	2048	2048	1280	1024
RAM (KB)	512	256	256	256	256	192	192	128
Data Flash [EEPROM] (KB)	128	64	64	64	64	64	64	64
USB OHCI + Device	–	2+0 or 1+1	2+0 or 1+1	2+0 or 1+1	2+0 or 1+1	2+0 or 1+1	2+0 or 1+1	–
EMAC	10/100	10/100	10/100	10/100	10/100	10/100	10/100	–
CAN	4	3	3	3	3	3	3	3
MibADC 12-bit (Ch)	2 (41ch)	2 (24ch)	2 (24ch)	2 (41ch)	2 (41ch)	2 (41ch)	2 (24ch)	2 (24ch)
N2HET (Ch)	2 (64)	2 (44)	2 (40)	2 (44)	2 (44)	2 (44)	2 (44)	2 (44)
ePWM Channels	14	–	–	–	–	–	14	14
eCAP Channels	6	–	–	–	–	–	6	6
eQEP Channels	2	–	–	–	–	–	2	2
MibSPI (CS)	5 (4 x 6 + 2)	3 (6 + 6 + 4)	3 (5 + 6 + 1)	3 (6 + 6 + 4)	3 (6 + 6 + 4)	3 (6 + 6 + 4)	3 (6 + 6 + 4)	3 (6 + 6 + 4)
SPI (CS)	–	2 (2 + 1)	1 (1)	2 (2 + 1)	2 (2 + 1)	2 (2 + 1)	2 (2 + 1)	2 (2 + 1)
SCI (LIN)	4 (2 with LIN)	2 (1 with LIN)	2 (1 with LIN)	2 (1 with LIN)	2 (1 with LIN)	2 (1 with LIN)	2 (1 with LIN)	2 (1 with LIN)
I ² C	2	1	1	1	1	1	1	1
GPIO (INT) ⁽⁴⁾	168 (with 16 interrupt capable)	144 (with 16 interrupt capable)	64 (with 4 interrupt capable)	144 (with 16 interrupt capable)	144 (with 16 interrupt capable)	144 (with 16 interrupt capable)	101 (with 16 interrupt capable)	101 (with 16 interrupt capable)
EMIF	16-bit data	16-bit data	–	16-bit data	16-bit data	16-bit data	16-bit data	–
ETM [Trace] (Data)	(32)	(32)	–	32-bit	32-bit	32-bit	–	–
RTP/DMM (Data)	(16/16)	(16/16)	–	16/16	16/16	16/16	–	–
Operating Temperature	-40°C to 105°C	-40°C to 105°C	-40°C to 105°C	-40°C to 105°C	-40°C to 105°C	-40°C to 105°C	-40°C to 105°C	-40°C to 105°C

(1) For additional device variants, see www.ti.com/rm

(2) This table reflects the maximum configuration for each peripheral. Some functions are multiplexed and not all pins are available at the same time.

(3) Superset device

(4) Total number of pins that can be used as general-purpose input or output when not used as part of a peripheral

Table 3-1. RM48L952 Device Comparison⁽¹⁾⁽²⁾ (continued)

FEATURES	DEVICES							
Core Supply (V)	1.14 V – 1.32 V	1.14 V – 1.32 V	1.14 V – 1.32 V	1.14 V – 1.32 V	1.14 V – 1.32 V	1.14 V – 1.32 V	1.14 V – 1.32 V	1.14 V – 1.32 V
I/O Supply (V)	3.0 V – 3.6 V	3.0 V – 3.6 V	3.0 V – 3.6 V	3.0 V – 3.6 V	3.0 V – 3.6 V	3.0 V – 3.6 V	3.0 V – 3.6 V	3.0 V – 3.6 V

4 Terminal Configuration and Functions

4.1 PGE QFP Package Pinout (144-Pin)

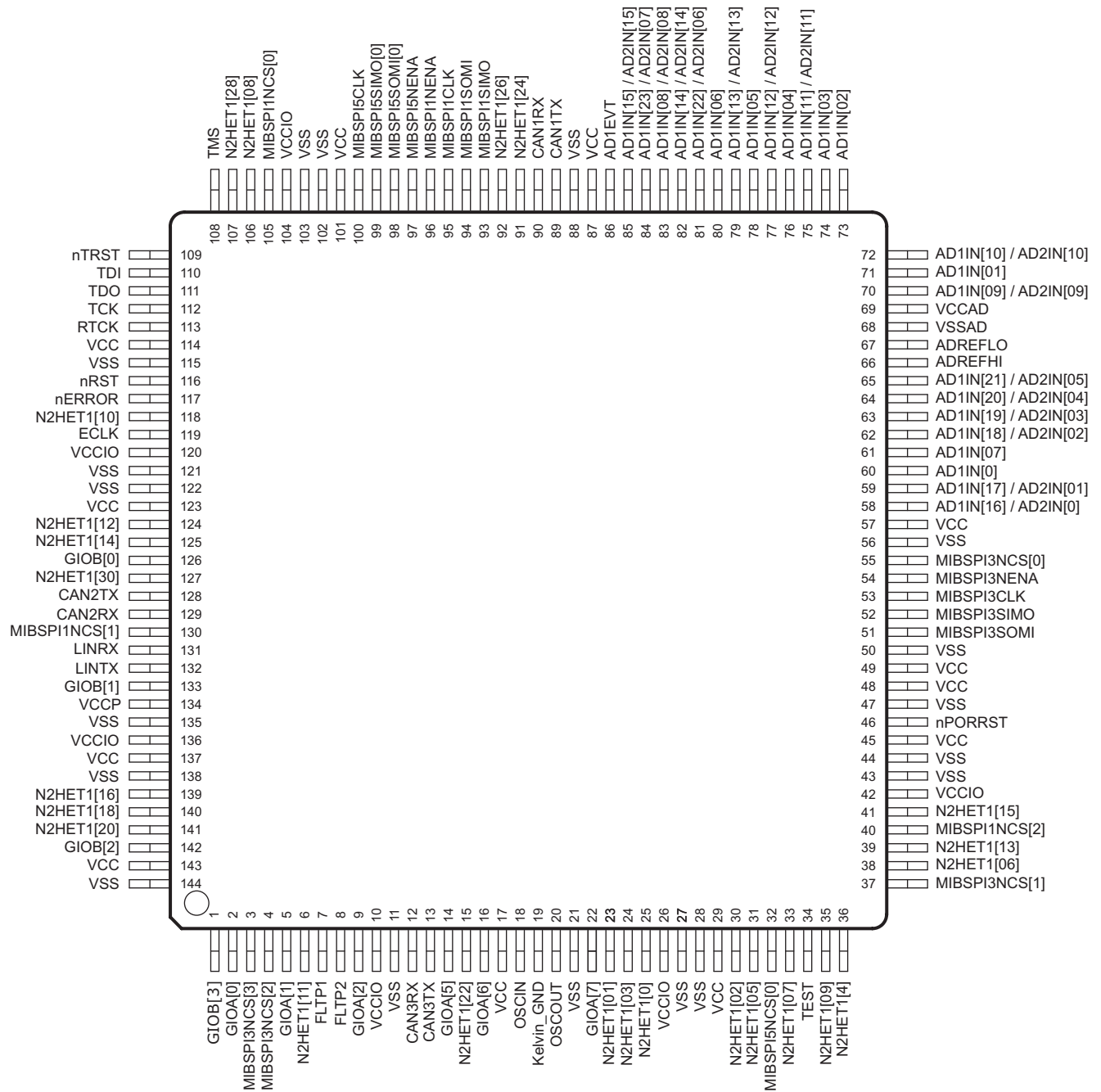

A. Pins can have multiplexed functions. Only the default function is depicted in the figure.

Figure 4-1. PGE QFP Package Pinout (144-Pin)^(A)

4.2 ZWT BGA Package Ball-Map (337-Ball Grid Array)

	A	B	C	D	E	F	G	H	J	K	L	M	N	P	R	T	U	V	W	
19	VSS	VSS	TMS	N2HET1 [10]	MIBSPI5 NCS[0]	MIBSPI1 SIMO	MIBSPI1 NENA	MIBSPI5 CLK	MIBSPI5 SOMI[0]	N2HET1 [28]	DMM DATA[0]	CAN3RX	AD1EVT	AD1IN[15] / AD2IN[15]	AD1IN[22] / AD2IN[06]	AD1IN [06]	AD1IN[11] / AD2IN[11]	VSSAD	VSSAD	19
18	VSS	TCK	TDO	nTRST	N2HET1 [08]	MIBSPI1 CLK	MIBSPI1 SOMI	MIBSPI5 NENA	MIBSPI5 SOMI[0]	N2HET1 [0]	DMM DATA[1]	CAN3TX	NC	AD1IN[08] / AD2IN[08]	AD1IN[14] / AD2IN[14]	AD1IN[13] / AD2IN[13]	AD1IN [04]	AD1IN [02]	VSSAD	18
17	TDI	RST	EMIF_ADDR[21]	EMIF_nWE	MIBSPI5 SOMI[1]	DMM_CLK	MIBSPI5 SOMI[3]	MIBSPI5 SOMI[2]	N2HET1 [31]	EMIF_nCS[3]	EMIF_nCS[2]	EMIF_nCS[4]	EMIF_nCS[0]	NC	AD1IN [05]	AD1IN [03]	AD1IN[10] / AD2IN[10]	AD1IN [01]	AD1IN[09] / AD2IN[09]	17
16	RTCK	NC	EMIF_ADDR[20]	EMIF_BA[1]	MIBSPI5 SIMO[1]	DMM_NENA	MIBSPI5 SOMI[3]	MIBSPI5 SOMI[2]	DMM_SYNC	NC	NC	NC	NC	NC	AD1IN[23] / AD2IN[07]	AD1IN[12] / AD2IN[12]	AD1IN[19] / AD2IN[03]	ADREFLO	VSSAD	16
15	NC	NC	EMIF_ADDR[19]	EMIF_ADDR[18]	ETM DATA[06]	ETM DATA[05]	ETM DATA[04]	ETM DATA[03]	ETM DATA[02]	ETM DATA[16]	ETM DATA[17]	ETM DATA[18]	ETM DATA[19]	NC	NC	AD1IN[21] / AD2IN[05]	AD1IN[20] / AD2IN[04]	ADREFHI	VCCAD	15
14	N2HET1 [26]	nERROR	EMIF_ADDR[17]	EMIF_ADDR[16]	ETM DATA[07]	VCCIO	VCCIO	VCCIO	VCC	VCC	VCCIO	VCCIO	VCCIO	VCCIO	NC	NC	AD1IN[18] / AD2IN[02]	AD1IN [07]	AD1IN [0]	14
13	N2HET1 [17]	N2HET1 [19]	EMIF_ADDR[15]	NC	ETM DATA[12]	VCCIO								VCCIO	ETM DATA[01]	NC	AD1IN[17] / AD2IN[01]	AD1IN[16] / AD2IN[0]	NC	13
12	ECLK	N2HET1 [04]	EMIF_ADDR[14]	NC	ETM DATA[13]	VCCIO		VSS	VSS	VCC	VSS	VSS		VCCIO	ETM DATA[0]	MIBSPI5 NCS[3]	NC	NC	NC	12
11	N2HET1 [14]	N2HET1 [30]	EMIF_ADDR[13]	NC	ETM DATA[14]	VCCIO		VSS	VSS	VSS	VSS	VSS		VCCPLL	ETM TRACE CTL	NC	NC	NC	NC	11
10	CAN1TX	CAN1RX	EMIF_ADDR[12]	NC	ETM DATA[15]	VCC		VCC	VSS	VSS	VSS	VCC		VCC	ETM TRACE CLKOUT	NC	NC	MIBSPI3 NCS[0]	GIOB[3]	10
9	N2HET1 [27]	NC	EMIF_ADDR[11]	NC	ETM DATA[08]	VCC		VSS	VSS	VSS	VSS			VCCIO	ETM TRACE CLKIN	NC	NC	MIBSPI3 CLK	MIBSPI3 NENA	9
8	NC	NC	EMIF_ADDR[10]	NC	ETM DATA[09]	VCCP		VSS	VSS	VCC	VSS	VSS		VCCIO	ETM DATA[31]	NC	NC	MIBSPI3 SOMI	MIBSPI3 SIMO	8
7	LINRX	LINTX	EMIF_ADDR[9]	NC	ETM DATA[10]	VCCIO								VCCIO	ETM DATA[30]	NC	NC	N2HET1 [09]	nPORRST	7
6	GIOA[4]	MIBSPI5 NCS[1]	EMIF_ADDR[8]	NC	ETM DATA[11]	VCCIO	VCCIO	VCCIO	VCCIO	VCC	VCC	VCCIO	VCCIO	VCCIO	ETM DATA[29]	NC	NC	N2HET1 [05]	MIBSPI5 NCS[2]	6
5	GIOA[0]	GIOA[5]	EMIF_ADDR[7]	EMIF_ADDR[1]	ETM DATA[20]	ETM DATA[21]	ETM DATA[22]	FLTP2	FLTP1	ETM DATA[23]	ETM DATA[24]	ETM DATA[25]	ETM DATA[26]	ETM DATA[27]	ETM DATA[28]	NC	NC	MIBSPI3 NCS[1]	N2HET1 [02]	5
4	N2HET1 [16]	N2HET1 [12]	EMIF_ADDR[6]	EMIF_ADDR[0]	NC	NC	NC	N2HET1 [21]	N2HET1 [23]	NC	NC	NC	NC	NC	EMIF_nCAS	NC	NC	NC	NC	4
3	N2HET1 [29]	N2HET1 [22]	MIBSPI3 NCS[3]	SPI2 NENA	N2HET1 [11]	MIBSPI1 NCS[1]	MIBSPI1 NCS[2]	GIOA[6]	MIBSPI1 NCS[3]	EMIF_CLK	EMIF_CKE	NH2ET1 [25]	SPI2 NCS[0]	EMIF_nWAIT	EMIF_nRAS	NC	NC	NC	N2HET1 [06]	3
2	VSS	MIBSPI3 NCS[2]	GIOA[1]	SPI2 SOMI	SPI2 CLK	GIOB[2]	GIOB[5]	CAN2TX	GIOB[6]	GIOB[1]	KELVIN_GND	GIOB[0]	N2HET1 [13]	N2HET1 [20]	MIBSPI1 NCS[0]	NC	TEST	N2HET1 [01]	VSS	2
1	VSS	VSS	GIOA[2]	SPI2 SIMO	GIOA[3]	GIOB[7]	GIOB[4]	CAN2RX	N2HET1 [18]	OSCIN	OSCOU	GIOA[7]	N2HET1 [15]	N2HET1 [24]	NC	N2HET1 [07]	N2HET1 [03]	VSS	VSS	1

A. Balls can have multiplexed functions. Only the default function, except for the EMIF signals that are multiplexed with ETM signals, is depicted in the figure.

Figure 4-2. ZWT Package Pinout. Top View^(A)

Note: Balls can have multiplexed functions. Only the default function is depicted in above diagram, except for the EMIF signals that are multiplexed with ETM signals.

4.3 Terminal Functions

Section 4.3.1 and Section 4.3.2 identify the external signal names, the associated pin or ball numbers along with the mechanical package designator, the pin or ball type (Input, Output, I/O, Power, or Ground), whether the pin or ball has any internal pullup or pulldown, whether the pin or ball can be configured as a GPIO, and a functional pin or ball description. The first signal name listed is the primary function for that terminal. The signal name in **bold** is the function being described. For information on how to select between different multiplexed functions, see the *RM48x 16/32-Bit RISC Flash Microcontroller Technical Reference Manual (SPNU503)*.

NOTE

In the Terminal Functions table below, the "Reset Pull State" is the state of the pull applied to the terminal while nPORRST is low and immediately after nPORRST goes High. The default pull direction may change when software configures the pin for an alternate function. The "Pull Type" is the type of pull asserted when the signal name in bold is enabled for the given terminal by the IOMM control registers.

All I/O signals except nRST are configured as inputs while nPORRST is low and immediately after nPORRST goes High. While nPORRST is low, the input buffers are disabled, and the output buffers are disabled with the default pulls enabled.

All output-only signals have the output buffer disabled and the default pull enabled while nPORRST is low, and are configured as outputs with the pulls disabled immediately after nPORRST goes High.

4.3.1 PGE Package

4.3.1.1 Multibuffered Analog-to-Digital Converters (MibADCs)

Table 4-1. PGE Multibuffered Analog-to-Digital Converters (MibADC1, MibADC2)

TERMINAL		SIGNAL TYPE	RESET PULL STATE	PULL TYPE	DESCRIPTION
SIGNAL NAME	144 PGE				
ADREFHI ⁽¹⁾	66	Input	N/A	None	ADC high reference supply
ADREFLO ⁽¹⁾	67	Input			ADC low reference supply
VCCAD ⁽¹⁾	69	Power			Operating supply for ADC
VSSAD ⁽¹⁾	68	Ground			
AD1EVT/MII_RX_ER/RMII_RX_ER	86	I/O	Pulldown	Programmable, 20 µA	ADC1 event trigger input, or GPIO
MIBSPI3NCS[0]/AD2EVT/GIOB[2]/N2HET2_PIN_nDIS	55	I/O	Pullup	Programmable, 20 µA	ADC2 event trigger input, or GPIO
AD1IN[0]	60	Input	N/A	None	ADC1 analog input
AD1IN[1]	71				
AD1IN[2]	73				
AD1IN[3]	74				
AD1IN[4]	76				
AD1IN[5]	78				
AD1IN[6]	80				
AD1IN[7]	61				

(1) The ADREFHI, ADREFLO, VCCAD and VSSAD connections are common for both ADC cores.

Table 4-1. PGE Multibuffered Analog-to-Digital Converters (MibADC1, MibADC2) (continued)

TERMINAL		SIGNAL TYPE	RESET PULL STATE	PULL TYPE	DESCRIPTION
SIGNAL NAME	144 PGE				
AD1IN[8] / AD2IN[8]	83	Input	N/A	None	ADC1/ADC2 shared analog inputs
AD1IN[9] / AD2IN[9]	70				
AD1IN[10] / AD2IN[10]	72				
AD1IN[11] / AD2IN[11]	75				
AD1IN[12] / AD2IN[12]	77				
AD1IN[13] / AD2IN[13]	79				
AD1IN[14] / AD2IN[14]	82				
AD1IN[15] / AD2IN[15]	85				
AD1IN[16] / AD2IN[0]	58				
AD1IN[17] / AD2IN[1]	59				
AD1IN[18] / AD2IN[2]	62				
AD1IN[19] / AD2IN[3]	63				
AD1IN[20] / AD2IN[4]	64				
AD1IN[21] / AD2IN[5]	65				
AD1IN[22] / AD2IN[6]	81				
AD1IN[23] / AD2IN[7]	84				

4.3.1.2 Enhanced High-End Timer (N2HET) Modules

Table 4-2. PGE Enhanced High-End Timer Modules (N2HET1, N2HET2)

TERMINAL		SIGNAL TYPE	RESET PULL STATE	PULL TYPE	DESCRIPTION
SIGNAL NAME	144 PGE				
N2HET1[0]/SPI4CLK	25	I/O	Pulldown	Programmable, 20 µA	N2HET1 timer input capture or output compare, or GIO.
N2HET1[1]/SPI4NENA/USB2.TXEN/USB_FUNC.PUENO/N2HET2[8]	23				
N2HET1[2]/SPI4SIMO[0]	30				
N2HET1[3]/SPI4NCS[0]/USB2.SPEED/USB_FUNC.PUENON/N2HET2[10]	24				
N2HET1[4]	36				
N2HET1[5]/SPI4SOMI[0]/N2HET2[12]	31				
N2HET1[6]/SCIRX	38				
N2HET1[7]/USB2.PortPower/USB_FUNC.GZO/N2HET2[14]	33				
N2HET1[8]/MIBSPI1SIMO[1]/MII_TXD[3]/USB1.OverCurrent	106				
N2HET1[9]/N2HET2[16]/USB2.SUSPEND/USB_FUNC.SUSPENDO	35				
N2HET1[10]/MII_TX_CLK/USB1.TXEN/MII_TX_AVCLK4	118				
N2HET1[11]/MIBSPI3NCS[4]/N2HET2[18]/USB2.OverCurrent/USB_FUNC.VBUSI	6				
N2HET1[12]/MII_CRS/RMII_CRS_DV	124				
N2HET1[13]/SCITX	39				
N2HET1[14]/USB1.TXSE0	125				
N2HET1[15]/MIBSPI1NCS[4]	41				
N2HET1[16]	139				
MIBSPI1NCS[1]/N2HET1[17]/MII_COL/USB1.SUSPEND	130	I/O	Pullup	Programmable, 20 µA	Each terminal has a suppression filter with a programmable duration.
N2HET1[18]	140	I/O	Pulldown	Programmable, 20 µA	
MIBSPI1NCS[2]/N2HET1[19]/MDIO	40	I/O	Pullup	Programmable, 20 µA	
N2HET1[20]	141	I/O	Pulldown	Programmable, 20 µA	
N2HET1[22]/USB2.TXSE0/USB_FUNC.SE00	15	I/O	Pulldown	Programmable, 20 µA	
MIBSPI1NENA/N2HET1[23]/MII_RXD[2]/USB1.VP	96	I/O	Pullup	Programmable, 20 µA	
N2HET1[24]/MIBSPI1NCS[5]/MII_RXD[0]/RMII_RXD[0]	91	I/O	Pulldown	Programmable, 20 µA	
MIBSPI3NCS[1]/N2HET1[25]/MDCLK	37	I/O	Pullup	Programmable, 20 µA	
N2HET1[26]/MII_RXD[1]/RMII_RXD[1]	92	I/O	Pulldown	Programmable, 20 µA	
MIBSPI3NCS[2]/I2C_SDA/N2HET1[27]	4	I/O	Pullup	Programmable, 20 µA	
N2HET1[28]/MII_RX_CLK/RMII_REFCLK/MII_RX_AVCLK4	107	I/O	Pulldown	Programmable, 20 µA	
MIBSPI3NCS[3]/I2C_SCL/N2HET1[29]	3	I/O	Pullup	Programmable, 20 µA	
N2HET1[30]/MII_RX_DV/USB1.SPEED	127	I/O	Pulldown	Programmable, 20 µA	
MIBSPI3NENA/MIBSPI3NCS[5]/N2HET1[31]	54	I/O	Pullup	Programmable, 20 µA	
GIOA[5]/EXTCLKIN/N2HET1_PIN_nDIS	14	I/O	Pulldown	Programmable, 20 µA	Disable selected PWM outputs

Table 4-2. PGE Enhanced High-End Timer Modules (N2HET1, N2HET2) (continued)

TERMINAL		SIGNAL TYPE	RESET PULL STATE	PULL TYPE	DESCRIPTION
SIGNAL NAME	144 PGE				
GIOA[2]/USB2.TXDAT/USB_FUNC.TXDO/N2HET2[0]	9	I/O	Pulldown	Programmable, 20 μ A	N2HET2 time input capture or output compare, or GPIO Each terminal has a suppression filter with a programmable duration.
GIOA[6]/N2HET2[4]	16				
GIOA[7]/N2HET2[6]	22				
N2HET1[1]/SPI4NENA/USB2.TXEN/USB_FUNC.PUENO/N2HET2[8]	23				
N2HET1[3]/SPI4NCS[0]/USB2.SPEED/USB_FUNC.PUENON/N2HET2[10]	24				
N2HET1[5]/SPI4SOMI[0]/N2HET2[12]	31				
N2HET1[7]/USB2.PortPower/USB_FUNC.GZO/ N2HET2[14]	33				
N2HET1[9]/N2HET2[16]/USB2.SUSPEND/ USB_FUNC.SUSPENDO	35				
N2HET1[11]/MIBSPI3NCS[4]/N2HET2[18]/USB2.OverCurrent/USB_FUNC.VBUSI	6				
MIBSPI3NCS[0]/AD2EVT/GIOB[2]/N2HET2_PIN_nDIS	55	I/O	Pullup	Programmable, 20 μ A	Disable selected PWM outputs

4.3.1.3 General-Purpose Input/Output (GPIO)

Table 4-3. PGE General-Purpose Input/Output (GPIO)

TERMINAL		SIGNAL TYPE	RESET PULL STATE	PULL TYPE	DESCRIPTION
SIGNAL NAME	144 PGE				
GIOA[0]/USB2.VP/USB_FUNC.RXDPI	2	I/O	Pulldown	Programmable, 20 μ A	General-purpose I/O. All GPIO terminals are capable of generating interrupts to the CPU on rising / falling / both edges.
GIOA[1]/USB2.VM/USB_FUNC.RXDMI	5				
GIOA[2]/USB2.TXDAT/USB_FUNC.TXDO/N2HET2[0]	9				
GIOA[5]/EXTCLKIN/N2HET1_PIN_nDIS	14				
GIOA[6]/N2HET2[4]	16				
GIOA[7]/N2HET2[6]	22				
GIOB[0]/USB1.TXDAT	126				
GIOB[1]/USB1.PortPower	133				
GIOB[2]/N2HET1_PIN_nDIS	142				
MIBSPI3NCS[0]/AD2EVT/GIOB[2]/N2HET2_PIN_nDIS	55 ⁽¹⁾				
GIOB[3]/USB2.RCV/USB_FUNC.RXDI	1		Pulldown		

(1) The application cannot output a level onto this terminal when it is configured as GIOB[2]. A pull-up is enabled on this input. This pull cannot be disabled, and is not programmable using the GIO module pull control registers.

4.3.1.4 Controller Area Network Controllers (DCANs)

Table 4-4. PGE Controller Area Network Controllers (DCAN)

TERMINAL		SIGNAL TYPE	RESET PULL STATE	PULL TYPE	DESCRIPTION
SIGNAL NAME	144 PGE				
CAN1RX	90	I/O	Pullup	Programmable, 20 μ A	CAN1 receive, or GPIO
CAN1TX	89				CAN1 transmit, or GPIO
CAN2RX	129				CAN2 receive, or GPIO
CAN2TX	128				CAN2 transmit, or GPIO
CAN3RX	12				CAN3 receive, or GPIO
CAN3TX	13				CAN3 transmit, or GPIO

4.3.1.5 Local Interconnect Network Interface Module (LIN)

Table 4-5. PGE Local Interconnect Network Interface Module (LIN)

TERMINAL		SIGNAL TYPE	RESET PULL STATE	PULL TYPE	DESCRIPTION
SIGNAL NAME	144 PGE				
LINRX	131	I/O	Pullup	Programmable, 20 μ A	LIN receive, or GPIO
LINTX	132				LIN transmit, or GPIO

4.3.1.6 Standard Serial Communication Interface (SCI)

Table 4-6. PGE Standard Serial Communication Interface (SCI)

TERMINAL		SIGNAL TYPE	RESET PULL STATE	PULL TYPE	DESCRIPTION
SIGNAL NAME	144 PGE				
N2HET1[6]/SCIRX	38	I/O	Pulldown	Programmable, 20 μ A	SCI receive, or GPIO
N2HET1[13]/SCITX	39				SCI transmit, or GPIO

4.3.1.7 Inter-Integrated Circuit Interface Module (I2C)

Table 4-7. PGE Inter-Integrated Circuit Interface Module (I2C)

TERMINAL		SIGNAL TYPE	RESET PULL STATE	PULL TYPE	DESCRIPTION
SIGNAL NAME	144 PGE				
MIBSPI3NCS[2]/I2C_SDA/N2HET1[27]	4	I/O	Pullup	Programmable, 20 μ A	I2C serial data, or GPIO
MIBSPI3NCS[3]/I2C_SCL/N2HET1[29]	3				I2C serial clock, or GPIO

4.3.1.8 Standard Serial Peripheral Interface (SPI)

Table 4-8. PGE Standard Serial Peripheral Interface (SPI)

TERMINAL		SIGNAL TYPE	RESET PULL STATE	PULL TYPE	DESCRIPTION
SIGNAL NAME	144 PGE				
N2HET1[0]/SPI4CLK	25	I/O	Pulldown	Programmable, 20 μ A	SPI4 clock, or GPIO
N2HET1[3]/SPI4NCS[0]/USB2.SPEED/ USB_FUNC.PUENON/N2HET2[10]	24				SPI4 chip select, or GPIO
N2HET1[1]/SPI4NENA/USB2.TXEN/ USB_FUNC.PUENO/N2HET2[8]	23				SPI4 enable, or GPIO
N2HET1[2]/SPI4SIMO[0]	30				SPI4 slave-input master-output, or GPIO
N2HET1[5]/SPI4SOMI[0]/N2HET2[12]	31				SPI4 slave-output master-input, or GPIO

4.3.1.9 Multibuffered Serial Peripheral Interface Modules (MibSPI)

Table 4-9. PGE Multibuffered Serial Peripheral Interface Modules (MibSPI)

TERMINAL		SIGNAL TYPE	RESET PULL STATE	PULL TYPE	DESCRIPTION
SIGNAL NAME	144 PGE				
MIBSPI1CLK	95	I/O	Pullup	Programmable, 20 µA	MibSPI1 clock, or GPIO
MIBSPI1NCS[0]/MIBSPI1SOMI[1]/MII_TXD[2]/USB1.RCV	105				MibSPI1 chip select, or GPIO
MIBSPI1NCS[1]/N2HET1[17]/MII_COL/USB1.SUSPEND	130				
MIBSPI1NCS[2]/N2HET1[19]/MDIO	40				
N2HET1[15]/MIBSPI1NCS[4]	41		Pulldown	Programmable, 20 µA	MibSPI1 chip select, or GPIO
N2HET1[24]/MIBSPI1NCS[5]/MII_RXD[0]/RMII_RXD[0]	91				
MIBSPI1NENA/N2HET1[23]/MII_RXD[2]/USB1.VP	96		Pullup	Programmable, 20 µA	MibSPI1 enable, or GPIO
MIBSPI1SIMO[0]	93				MibSPI1 slave-in master-out, or GPIO
N2HET1[8]/MIBSPI1SIMO[1]/MII_TXD[3]/USB1.OverCurrent	106		Pulldown	Programmable, 20 µA	MibSPI1 slave-in master-out, or GPIO
MIBSPI1SOMI[0]	94				
MIBSPI1NCS[0]/MIBSPI1SOMI[1]/MII_TXD[2]/USB1.RCV	105	Pullup	Programmable, 20 µA	MibSPI1 slave-out master-in, or GPIO	
MIBSPI3CLK	53				I/O
MIBSPI3NCS[0]/AD2EVT/GIOB[2]/N2HET2_PIN_nDIS	55	MibSPI3 chip select, or GPIO			
MIBSPI3NCS[1]/N2HET1[25]/MDCLK	37				
MIBSPI3NCS[2]/I2C_SDA/N2HET1[27]	4				
MIBSPI3NCS[3]/I2C_SCL/N2HET1[29]	3	Pulldown	Programmable, 20 µA	MibSPI3 chip select, or GPIO	
N2HET1[11]/MIBSPI3NCS[4]/N2HET2[18]/USB2.OverCurrent/USB_FUNC.VBUSI	6				
MIBSPI3NENA /MIBSPI3NCS[5]/N2HET1[31]	54	Pullup	Programmable, 20 µA	MibSPI3 chip select, or GPIO	
MIBSPI3NENA/MIBSPI3NCS[5]/N2HET1[31]	54			MibSPI3 enable, or GPIO	
MIBSPI3SIMO[0]	52			MibSPI3 slave-in master-out, or GPIO	
MIBSPI3SOMI[0]	51			MibSPI3 slave-out master-in, or GPIO	
MIBSPI5CLK/MII_TXEN/RMII_TXEN	100	I/O	Pullup	Programmable, 20 µA	MibSPI5 clock, or GPIO
MIBSPI5NCS[0]	32				MibSPI5 chip select, or GPIO
MIBSPI5NENA/MII_RXD[3]/USB1.VM	97				MibSPI5 enable, or GPIO
MIBSPI5SIMO[0]/MII_TXD[1]/RMII_TXD[1]	99				MibSPI5 slave-in master-out, or GPIO
MIBSPI5SOMI[0]/MII_TXD[0]/RMII_TXD[0]	98				MibSPI5 slave-out master-in, or GPIO

4.3.1.10 Ethernet Controller

Table 4-10. PGE Ethernet Controller: MDIO Interface

TERMINAL		SIGNAL TYPE	RESET PULL STATE	PULL TYPE	DESCRIPTION
SIGNAL NAME	144 PGE				
MIBSPI3NCS[1]/N2HET1[25]/MDCLK	37	Output	Pullup	Programmable, 20 µA	Serial clock output
MIBSPI1NCS[2]/N2HET1[19]/MDIO	40	I/O	Pullup	Fixed 20 µA Pullup	Serial data input/output

Table 4-11. PGE Ethernet Controller: Reduced Media Independent Interface (RMII)

TERMINAL		SIGNAL TYPE	RESET PULL STATE	PULL TYPE	DESCRIPTION
SIGNAL NAME	144 PGE				
N2HET1[12]/MII_CRS/RMII_CRS_DV	124	Input	Pulldown	Fixed 20 μ A Pulldown	RMII carrier sense and data valid
N2HET1[28]/MII_RX_CLK/RMII_REFCLK/MII_RX_AVCLK4	107				RMII synchronous reference clock for receive, transmit and control interface
AD1EVT/MII_RX_ER/RMII_RX_ER	86				RMII receive error
N2HET1[24]/MIBSPI1NCS[5]/MII_RXD[0]/RMII_RXD[0]	91				RMII receive data
N2HET1[26]/MII_RXD[1]/RMII_RXD[1]	92				
MIBSPI5SOMI[0]/MII_TXD[0]/RMII_TXD[0]	98	Output	Pullup	None	RMII transmit data
MIBSPI5SIMO[0]/MII_TXD[1]/RMII_TXD[1]	99				RMII transmit enable
MIBSPI5CLK/MII_TXEN/RMII_TXEN	100				

Table 4-12. PGE Ethernet Controller: Media Independent Interface (MII)

TERMINAL		SIGNAL TYPE	RESET PULL STATE	PULL TYPE	DESCRIPTION
SIGNAL NAME	144 PGE				
MIBSPI1NCS[1]/N2HET1[17]/MII_COL/USB1.SUSPEND	130	Input	Pullup	None	Collision detect
N2HET1[12]/MII_CRS/RMII_CRS_DV	124		Pulldown	Fixed 20 μ A Pulldown	Carrier sense and receive valid
N2HET1[28]/MII_RX_CLK/RMII_REFCLK/MII_RX_AVCLK4	107	I/O	Pulldown	None	MII output receive clock
N2HET1[30]/MII_RX_DV/USB1.SPEED	127	Input	Pulldown	Fixed 20 μ A Pulldown	Received data valid
AD1EVT/MII_RX_ER/RMII_RX_ER	86				Receive error
N2HET1[28]/MII_RX_CLK/RMII_REFCLK/MII_RX_AVCLK4	107	I/O	Pulldown	Fixed 20 μ A Pulldown	Receive clock
N2HET1[24]/MIBSPI1NCS[5]/MII_RXD[0]/RMII_RXD[0]	91	Input			Pullup
N2HET1[26]/MII_RXD[1]/RMII_RXD[1]	92				
MIBSPI1NENA/N2HET1[23]/MII_RXD[2]/USB1.VP	96				
MIBSPI5NENA/MII_RXD[3]/USB1.VM	97				
N2HET1[10]/MII_TX_CLK/USB1.TXEN/MII_TX_AVCLK4	118	I/O	Pulldown	None	MII output transmit clock
N2HET1[10]/MII_TX_CLK/USB1.TXEN/MII_TX_AVCLK4	118				Transmit clock
MIBSPI5SOMI[0]/MII_TXD[0]/RMII_TXD[0]	98	Output	Pullup	None	Transmit data
MIBSPI5SIMO[0]/MII_TXD[1]/RMII_TXD[1]	99				
MIBSPI1NCS[0]/MIBSPI1SOMI[1]/MII_TXD[2]/USB1.RCV	105				
N2HET1[8]/MIBSPI1SIMO[1]/MII_TXD[3]/USB1.OverCurrent	106		Pulldown	None	
MIBSPI5CLK/MII_TXEN/RMII_TXEN	100		Pullup	None	Transmit enable

4.3.1.11 USB Host and Device Port Controller Interface

The USB Host Controller includes a root hub with two ports. USB1 pins are for Root Hub Port 0. USB2 pins are for Root Hub Port 1.

Table 4-13. PGE USB Host Port Controller Interface (USB1, USB2)

TERMINAL		SIGNAL TYPE	RESET PULL STATE	PULL TYPE	DESCRIPTION	
SIGNAL NAME	144 PGE					
N2HET1[8]/MIBSPI1SIMO[1]/MII_TXD[3] /USB1.OVERCURRENT	106	Input	Pulldown	Fixed 20 μ A Pullup	Active-low input, asserted during overcurrent condition from USB power switch	
MIBSPI1NCS[0]/MIBSPI1SOMI[1]/MII_TXD[2]/ USB1.RCV	105		Pullup	Fixed 20 μ A Pullup	Fixed 20 μ A Pullup	USB Receive Data, converted from differential (D+/D– to single ended by transceiver)
MIBSPI5NENA/MII_RXD[3]/ USB1.VM	97					Single-ended D– Input, driven by transceiver
MIBSPI1NENA/N2HET1[23]/MII_RXD[2]/ USB1.VP	96					Single-ended D+ Input, driven by transceiver
GIOB[1]/ USB1.PORTPOWER	133	Output	Pulldown	None	Active-high output enable for controlling an external USB power switch	
N2HET1[30]/MII_RX_DV/ USB1.SPEED	127				Transmit speed to USB port transceiver. 0 = Low Speed 1 = Full Speed	
MIBSPI1NCS[1]/N2HET1[17]/MII_COL/ USB1.SUSPEND	130		Pullup	None	This signal indicates the state of the port, active or suspend. 0 = Active 1 = Suspend	
GIOB[0]/ USB1.TXDAT	126		Pulldown	None	None	Single-Ended USB Data Output to USB Transceiver. Use in combination with USB1.TXSE0
N2HET1[10]/MII_TX_CLK/ USB1.TXEN /MII_TX_AVCLK4	118					Active-low output transmit enable to port transceiver
N2HET1[14]/ USB1.TXSE0	125					Active High Output – Instructs Transceiver to transmit single-ended zero.
N2HET1[11]/MIBSPI3NCS[4]/N2HET2[18]/ USB2.OVERCURRENT/USB_FUNC.VBUSI	6		Input	Pulldown	Fixed 20 μ A Pullup	Active-low input, asserted during overcurrent condition from USB power switch
GIOB[3]/ USB2.RCV/USB_FUNC.RXDI	1	Pulldown		Fixed 20 μ A Pullup	Fixed 20 μ A Pullup	USB Receive Data, converted from differential (D+/D– to single ended by transceiver).
GIOA[1]/ USB2.VM/USB_FUNC.RXDMI	5					Single-ended D– Input, driven by transceiver
GIOA[0]/ USB2.VP/USB_FUNC.RXDPI	2					Single-ended D+ Input, driven by transceiver

Table 4-13. PGE USB Host Port Controller Interface (USB1, USB2) (continued)

TERMINAL		SIGNAL TYPE	RESET PULL STATE	PULL TYPE	DESCRIPTION
SIGNAL NAME	144 PGE				
N2HET1[7]/USB2.PORTPOWER/ USB_FUNC.GZO/N2HET2[14]	33	Output	Pulldown	None	Active-high output enable for controlling an external USB power switch
N2HET1[3]/SPI4NCS[0]/USB2.SPEED/ USB_FUNC.PUENON/N2HET2[10]	24				Transmit speed to USB port transceiver. 0 = Low Speed 1 = Full Speed
N2HET1[9]/N2HET2[16]/USB2.SUSPEND/ USB_FUNC.SUSPENDO	35				This signal indicates the state of the port, active or suspend. 0 = Active 1 = Suspend
GIOA[2]/USB2.TXDAT/USB_FUNC.TXDO/N2HET2[0]	9				Single-Ended USB Data Output to USB Transceiver. Use in combination with USB2.TXSE0
N2HET1[1]/SPI4NENA/USB2.TXEN/ USB_FUNC.PUENO/N2HET2[8]	23				Active-low output transmit enable to port transceiver
N2HET1[22]/USB2.TXSE0/USB_FUNC.SE00	15				Active High Output – Instructs Transceiver to transmit single-ended zero.

Table 4-14. PGE USB Device Port Controller Interface (USB_FUNC)

TERMINAL		SIGNAL TYPE	RESET PULL STATE	PULL TYPE	DESCRIPTION
SIGNAL NAME	144 PGE				
N2HET1[7]/USB2.PortPower/USB_FUNC.GZO/N2HET2[14]	33	Output	Pulldown	None	Active-low output USB device transmit enable to port transceiver
N2HET1[1]/SPI4NENA/USB2.TXEN/USB_FUNC.PUENO/ N2HET2[8]	23				Pull-up enable, allows for software-programmable USB device connect/disconnect
N2HET1[3]/SPI4NCS[0]/USB2.SPEED/USB_FUNC.PUENON/ N2HET2[10]	24				PUENO inverted
GIOB[3]/USB2.RCV/USB_FUNC.RXDI	1	Input	Pulldown	Fixed 20 µA Pullup	USB Receive Data, converted from differential (D+/D– to single ended by transceiver).
GIOA[1]/USB2.VM/USB_FUNC.RXDMI	5				Single-ended D– Input, driven by transceiver
GIOA[0]/USB2.VP/USB_FUNC.RXDPI	2				Single-ended D+ Input, driven by transceiver
N2HET1[22]/USB2.TXSE0/USB_FUNC.SE00	15	Output	Pulldown	None	Active High Output – Instructs Transceiver to transmit single-ended zero.
N2HET1[9]/N2HET2[16]/USB2.SUSPEND/ USB_FUNC.SUSPENDO	35				Active High Output – USB device suspend output. This function is asserted when the USB bus has detected an idle mode during 5 ms.
GIOA[2]/USB2.TXDAT/USB_FUNC.TXDO/N2HET2[0]	9				Single-Ended USB Data Output to USB Transceiver. Use in combination with USB_FUNC.SE00
N2HET1[11]/MIBSPI3NCS[4]/N2HET2[18]/ USB2.OverCurrent/USB_FUNC.VBUSI	6	Input	Pulldown	Fixed 20 µA Pulldown	Must be pulled up or down to reflect the state of power on the VBUS terminal of the USB device connector. This terminal is not 5 V tolerant.

4.3.1.12 System Module Interface

Table 4-15. PGE System Module Interface

TERMINAL		144 PGE	SIGNAL TYPE	RESET PULL STATE	PULL TYPE	DESCRIPTION
SIGNAL NAME						
nPORRST		46	Input	Pulldown	Fixed 100 μ A Pulldown	Power-on reset, cold reset External power supply monitor circuitry must drive nPORRST low when any of the supplies to the microcontroller fall out of the specified range. This terminal has a glitch filter. See Section 6.8 .
nRST		116	I/O	Pullup	Fixed 100 μ A Pullup	System reset, warm reset, bidirectional. The internal circuitry indicates any reset condition by driving nRST low. The external circuitry can assert a system reset by driving nRST low. To ensure that an external reset is not arbitrarily generated, TI recommends that an external pullup resistor is connected to this terminal. This terminal has a glitch filter. See Section 6.8 .
nERROR		117	I/O	Pulldown	Fixed 20 μ A Pulldown	ESM Error Signal Indicates error of high severity. See Section 6.18 .

4.3.1.13 Clock Inputs and Outputs

Table 4-16. PGE Clock Inputs and Outputs

TERMINAL		144 PGE	SIGNAL TYPE	RESET PULL STATE	PULL TYPE	DESCRIPTION
SIGNAL NAME						
OSCIN		18	Input	N/A	None	From external crystal/resonator, or external clock input
KELVIN_GND		19	Input			Kelvin ground for oscillator
OSCOU		20	Output			To external crystal/resonator
ECLK		119	I/O	Pulldown	Programmable, 20 μ A	External prescaled clock output, or GIO.
GIOA[5]/EXTCLKIN/N2HET1_PIN_nDIS		14	Input	Pulldown	20 μ A	External clock input #1

4.3.1.14 Test and Debug Modules Interface

Table 4-17. PGE Test and Debug Modules Interface

TERMINAL		144 PGE	SIGNAL TYPE	RESET PULL STATE	PULL TYPE	DESCRIPTION
SIGNAL NAME						
TEST		34	I/O	Pulldown	Fixed 100 μ A Pulldown	Test enable. This terminal must be connected to ground directly or via a pulldown resistor.
nTRST		109	Input			JTAG test hardware reset
RTCK		113	Output	N/A	None	JTAG return test clock
TCK		112	Input	Pulldown	Fixed 100 μ A Pulldown	JTAG test clock
TDI		110	I/O	Pullup	Fixed 100 μ A Pullup	JTAG test data in

Table 4-17. PGE Test and Debug Modules Interface (continued)

TERMINAL		SIGNAL TYPE	RESET PULL STATE	PULL TYPE	DESCRIPTION
SIGNAL NAME	144 PGE				
TDO	111	Output	100 μ A Pulldown	None	JTAG test data out
TMS	108	I/O	Pullup	Fixed 100 μ A Pullup	JTAG test select

4.3.1.15 Flash Supply and Test Pads

Table 4-18. PGE Flash Supply and Test Pads

TERMINAL		SIGNAL TYPE	RESET PULL STATE	PULL TYPE	DESCRIPTION
SIGNAL NAME	144 PGE				
VCCP	134	3.3-V Power	N/A	None	Flash pump supply
FLTP1	7		N/A	None	Flash test pads. These terminals are reserved for TI use only. For proper operation these terminals must connect only to a test pad or not be connected at all [no connect (NC)].
FLTP2	8				

4.3.1.16 Supply for Core Logic: 1.2-V Nominal

Table 4-19. PGE Supply for Core Logic: 1.2-V Nominal

TERMINAL		SIGNAL TYPE	RESET PULL STATE	PULL TYPE	DESCRIPTION
SIGNAL NAME	144 PGE				
VCC	17	1.2-V Power	N/A	None	1.2-V Core supply
VCC	29				
VCC	45				
VCC	48				
VCC	49				
VCC	57				
VCC	87				
VCC	101				
VCC	114				
VCC	123				
VCC	137				
VCC	143				

4.3.1.17 Supply for I/O Cells: 3.3-V Nominal

Table 4-20. PGE Supply for I/O Cells: 3.3-V Nominal

TERMINAL		SIGNAL TYPE	RESET PULL STATE	PULL TYPE	DESCRIPTION
SIGNAL NAME	144 PGE				
VCCIO	10	3.3-V Power	N/A	None	3.3-V Operating supply for I/Os
VCCIO	26				
VCCIO	42				
VCCIO	104				
VCCIO	120				
VCCIO	136				

4.3.1.18 Ground Reference for All Supplies Except VCCAD
Table 4-21. PGE Ground Reference for All Supplies Except VCCAD

TERMINAL		SIGNAL TYPE	RESET PULL STATE	PULL TYPE	DESCRIPTION
SIGNAL NAME	144 PGE				
VSS	11	Ground	N/A	None	Ground reference
VSS	21				
VSS	27				
VSS	28				
VSS	43				
VSS	44				
VSS	47				
VSS	50				
VSS	56				
VSS	88				
VSS	102				
VSS	103				
VSS	115				
VSS	121				
VSS	122				
VSS	135				
VSS	138				
VSS	144				

4.3.2 ZWT Package

4.3.2.1 Multibuffered Analog-to-Digital Converters (MibADCs)

Table 4-22. ZWT Multibuffered Analog-to-Digital Converters (MibADC1, MibADC2)

TERMINAL		SIGNAL TYPE	RESET PULL STATE	PULL TYPE	DESCRIPTION
SIGNAL NAME	337 ZWT				
ADREFHI ⁽¹⁾	V15	Input	N/A	None	ADC high reference supply
ADREFLO ⁽¹⁾	V16	Input			ADC low reference supply
VCCAD ⁽¹⁾	W15	Power			Operating supply for ADC
VSSAD	V19	Ground	N/A	None	ADC supply power
VSSAD	W16				
VSSAD	W18				
VSSAD	W19				
AD1EVT/MII_RX_ER/RMII_RX_ER	N19	I/O	Pulldown	Programmable, 20 µA	ADC1 event trigger input, or GPIO
MIBSPI3NCS[0]/AD2EVT/GIOB[2]/N2HET2_PIN_nDIS	V10	I/O	Pullup	Programmable, 20 µA	ADC2 event trigger input, or GPIO
AD1IN[0]	W14	Input	N/A	None	ADC1 analog input
AD1IN[1]	V17				
AD1IN[2]	V18				
AD1IN[3]	T17				
AD1IN[4]	U18				
AD1IN[5]	R17				
AD1IN[6]	T19				
AD1IN[7]	V14				
AD1IN[8] / AD2IN[8]	P18	Input	N/A	None	ADC1/ADC2 shared analog inputs
AD1IN[9] / AD2IN[9]	W17				
AD1IN[10] / AD2IN[10]	U17				
AD1IN[11] / AD2IN[11]	U19				
AD1IN[12] / AD2IN[12]	T16				
AD1IN[13] / AD2IN[13]	T18				
AD1IN[14] / AD2IN[14]	R18				
AD1IN[15] / AD2IN[15]	P19				
AD1IN[16] / AD2IN[0]	V13				
AD1IN[17] / AD2IN[1]	U13				
AD1IN[18] / AD2IN[2]	U14				
AD1IN[19] / AD2IN[3]	U16				
AD1IN[20] / AD2IN[4]	U15				
AD1IN[21] / AD2IN[5]	T15				
AD1IN[22] / AD2IN[6]	R19				
AD1IN[23] / AD2IN[7]	R16				

(1) The ADREFHI, ADREFLO, VCCAD and VSSAD connections are common for both ADC cores.

4.3.2.2 Enhanced High-End Timer (N2HET) Modules

Table 4-23. ZWT Enhanced High-End Timer (N2HET) Modules

TERMINAL		SIGNAL TYPE	RESET PULL STATE	PULL TYPE	DESCRIPTION
SIGNAL NAME	337 ZWT				
N2HET1[0]/SPI4CLK	K18	I/O	Pulldown	Programmable, 20 µA	N2HET1 time input capture or output compare, or GPIO. Each terminal has a suppression filter with a programmable duration.
N2HET1[1]/SPI4NENA/USB2.TXEN/ USB_FUNC.PUENO/N2HET2[8]	V2				
N2HET1[2]/SPI4SIMO[0]	W5				
N2HET1[3]/SPI4NCS[0]/USB2.SPEED/ USB_FUNC.PUENON/N2HET2[10]	U1				
N2HET1[4]	B12				
N2HET1[5]/SPI4SOMI[0]/N2HET2[12]	V6				
N2HET1[6]/SCIRX	W3				
N2HET1[7]/USB2.PortPower/ USB_FUNC.GZO/N2HET2[14]	T1				
N2HET1[8]/MIBSPI1SIMO[1]/MII_TXD[3]/ USB1.OverCurrent	E18				
N2HET1[9]/N2HET2[16]/ USB2.SUSPEND/USB_FUNC.SUSPENDO	V7				
N2HET1[10]/MII_TX_CLK/ USB1.TXEN/MII_TX_AVCLK4	D19				
N2HET1[11]/MIBSPI3NCS[4]/N2HET2[18]/ USB2.OverCurrent/USB_FUNC.VBUSI	E3				
N2HET1[12]/MII_CRS/RMII_CRS_DV	B4				
N2HET1[13]/SCITX	N2				
N2HET1[14]/USB1.TXSE0	A11				
N2HET1[15]/MIBSPI1NCS[4]	N1				
N2HET1[16]	A4				
N2HET1[17]	A13				
MIBSPI1NCS[1]/N2HET1[17]/MII_COL/USB1.SUSPEND	F3				
N2HET1[18]	J1				
N2HET1[19]	B13				
MIBSPI1NCS[2]/N2HET1[19]/MDIO	G3				
N2HET1[20]	P2				
N2HET1[21]	H4				
MIBSPI1NCS[3]/N2HET1[21]	J3				
N2HET1[22]/USB2.TXSE0/USB_FUNC.SE00	B3				
N2HET1[23]	J4				
MIBSPI1NENA/N2HET1[23]/MII_RXD[2]/ USB1.VP	G19				
N2HET1[24]/MIBSPI1NCS[5]/MII_RXD[0]/RMII_RXD[0]	P1				
N2HET1[25]	M3				
MIBSPI3NCS[1]/N2HET1[25]/MDCLK	V5				
N2HET1[26]/MII_RXD[1]/RMII_RXD[1]	A14				
N2HET1[27]	A9				
MIBSPI3NCS[2]/I2C_SDA/N2HET1[27]	B2				
N2HET1[28]/MII_RX_CLK/RMII_REFCLK/MII_RX_AVCLK4	K19				
N2HET1[29]	A3				
MIBSPI3NCS[3]/I2C_SCL/N2HET1[29]	C3				
N2HET1[30]/MII_RX_DV/USB1.SPEED	B11				
N2HET1[31]	J17				
MIBSPI3NENA/MIBSPI3NCS[5]/N2HET1[31]	W9				
GIOA[5]/EXTCLKIN/N2HET1_PIN_nDIS	B5	I/O	Pulldown	Programmable, 20 µA	Disable selected PWM outputs

Table 4-23. ZWT Enhanced High-End Timer (N2HET) Modules (continued)

TERMINAL		SIGNAL TYPE	RESET PULL STATE	PULL TYPE	DESCRIPTION
SIGNAL NAME	337 ZWT				
GIOA[2]/USB2.TXDAT/USB_FUNC.TXDO/ N2HET2[0]	C1	I/O	Pulldown	Programmable, 20 µA	N2HET2 time input capture or output compare, or GIO. Each terminal has a suppression filter with a programmable duration.
EMIF_ADDR[0]/ N2HET2[1]	D4				
GIOA[3]/ N2HET2[2]	E1				
EMIF_ADDR[1]/ N2HET2[3]	D5				
GIOA[6]/ N2HET2[4]	H3				
EMIF_BA[1]/ N2HET2[5]	D16				
GIOA[7]/ N2HET2[6]	M1				
EMIF_nCS[0]/RTP_DATA[15]/ N2HET2[7]	N17				
N2HET1[1]/SPI4NENA/USB2.TXEN/ USB_FUNC.PUENO/ N2HET2[8]	V2				
EMIF_nCS[3]/RTP_DATA[14]/ N2HET2[9]	K17				
N2HET1[3]/SPI4NCS[0]/USB2.SPEED/ USB_FUNC.PUENON/ N2HET2[10]	U1				
EMIF_ADDR[6]/RTP_DATA[13]/ N2HET2[11]	C4				
N2HET1[5]/SPI4SOMI[0]/ N2HET2[12]	V6				
EMIF_ADDR[7]/RTP_DATA[12]/ N2HET2[13]	C5				
N2HET1[7]/USB2.PortPower/ USB_FUNC.GZO/ N2HET2[14]	T1				
EMIF_ADDR[8]/RTP_DATA[11]/ N2HET2[15]	C6				
N2HET1[9]/ N2HET2[16] /USB2.SUSPEND/ USB_FUNC.SUSPENDO	V7				
N2HET1[11]/MIBSPI3NCS[4]/ N2HET2[18] / USB2.OverCurrent/USB_FUNC.VBUSI	E3				
MIBSPI3NCS[0]/AD2EVT/GIOB[2]/ N2HET2_PIN_nDIS	V10	I/O	Pullup	Programmable, 20 µA	Disable selected PWM outputs

4.3.2.3 General-Purpose Input/Output (GPIO)

Table 4-24. ZWT General-Purpose Input/Output (GPIO)

TERMINAL		SIGNAL TYPE	RESET PULL STATE	PULL TYPE	DESCRIPTION
SIGNAL NAME	337 ZWT				
GIOA[0]/USB2.VP/USB_FUNC.RXDPI	A5	I/O	Pulldown	Programmable, 20 μ A	General-purpose I/O. All GPIO terminals are capable of generating interrupts to the CPU on rising / falling / both edges.
GIOA[1]/USB2.VM/USB_FUNC.RXDPI	C2				
GIOA[2]/USB2.TXDAT/USB_FUNC.TXDO/N2HET2[0]	C1				
GIOA[3]/N2HET2[2]	E1				
GIOA[4]	A6				
GIOA[5]/EXTCLKIN/N2HET1_PIN_nDIS	B5				
GIOA[6]/N2HET2[4]	H3				
GIOA[7]/N2HET2[6]	M1				
GIOB[0]/USB1.TXDAT	M2				
GIOB[1]/USB1.PortPower	K2				
GIOB[2]	F2				
GIOB[3]/USB2.RCV /USB_FUNC.RXDI	W10				
GIOB[4]	G1				
GIOB[5]	G2				
GIOB[6]	J2				
GIOB[7]	F1				
MIBSPI3NCS[0]/AD2EVT/GIOB[2]/N2HET2_PIN_nDIS	V10		Pullup	Fixed 20 μ A Pulldown	The application cannot output a level onto this terminal when it is configured as GIOB[2]. A pull-up is enabled on this input. This pull cannot be disabled, and is not programmable using the GIO module pull control registers

4.3.2.4 Controller Area Network Controllers (DCANs)

Table 4-25. ZWT Controller Area Network Controllers (DCANs)

TERMINAL		SIGNAL TYPE	RESET PULL STATE	PULL TYPE	DESCRIPTION
SIGNAL NAME	337 ZWT				
CAN1RX	B10	I/O	Pullup	Programmable, 20 μ A	CAN1 receive, or GPIO
CAN1TX	A10				CAN1 transmit, or GPIO
CAN2RX	H1				CAN2 receive, or GPIO
CAN2TX	H2				CAN2 transmit, or GPIO
CAN3RX	M19				CAN3 receive, or GPIO
CAN3TX	M18				CAN3 transmit, or GPIO

4.3.2.5 Local Interconnect Network Interface Module (LIN)

Table 4-26. ZWT Local Interconnect Network Interface Module (LIN)

TERMINAL		SIGNAL TYPE	RESET PULL STATE	PULL TYPE	DESCRIPTION
SIGNAL NAME	337 ZWT				
LINRX	A7	I/O	Pullup	Programmable, 20 μ A	LIN receive, or GPIO
LINTX	B7				LIN transmit, or GPIO

4.3.2.6 Standard Serial Communication Interface (SCI)

Table 4-27. ZWT Standard Serial Communication Interface (SCI)

TERMINAL		SIGNAL TYPE	RESET PULL STATE	PULL TYPE	DESCRIPTION
SIGNAL NAME	337 ZWT				
N2HET1[6]/SCIRX	W3	I/O	Pulldown	Programmable, 20 μ A	SCI receive, or GPIO
N2HET1[13]/SCITX	N2				SCI transmit, or GPIO

4.3.2.7 Inter-Integrated Circuit Interface Module (I2C)

Table 4-28. ZWT Inter-Integrated Circuit Interface Module (I2C)

TERMINAL		SIGNAL TYPE	RESET PULL STATE	PULL TYPE	DESCRIPTION
SIGNAL NAME	337 ZWT				
MIBSPI3NCS[2]/I2C_SDA/N2HET1[27]	B2	I/O	Pullup	Programmable, 20 μ A	I2C serial data, or GPIO
MIBSPI3NCS[3]/I2C_SCL/N2HET1[29]	C3				I2C serial clock, or GPIO

4.3.2.8 Standard Serial Peripheral Interface (SPI)

Table 4-29. ZWT Standard Serial Peripheral Interface (SPI)

TERMINAL		SIGNAL TYPE	RESET PULL STATE	PULL TYPE	DESCRIPTION
SIGNAL NAME	337 ZWT				
SPI2CLK	E2	I/O	Pullup	Programmable, 20 μ A	SPI2 clock, or GPIO
SPI2NCS[0]	N3				SPI2 chip select, or GPIO
SPI2NENA/SPI2NCS[1]	D3				SPI2 chip select, or GPIO
SPI2NENA/SPI2NCS[1]	D3				SPI2 enable, or GPIO
SPI2SIMO[0]	D1				SPI2 slave-input master-output, or GPIO
SPI2SOMI[0]	D2				SPI2 slave-output master-input, or GPIO
N2HET1[0]/SPI4CLK	K18	I/O	Pulldown	Programmable, 20 μ A	SPI4 clock, or GPIO
N2HET1[3]/SPI4NCS[0]/USB2.SPEED/ USB_FUNC.PUENON/N2HET2[10]	U1				SPI4 chip select, or GPIO
N2HET1[1]/SPI4NENA/USB2.TXEN/ USB_FUNC.PUENO/N2HET2[8]	V2				SPI4 enable, or GPIO
N2HET1[2]/SPI4SIMO[0]	W5				SPI4 slave-input master-output, or GPIO
N2HET1[5]/SPI4SOMI[0]/N2HET2[12]	V6				SPI4 slave-output master-input, or GPIO

4.3.2.9 Multibuffered Serial Peripheral Interface Modules (MibSPI)

Table 4-30. ZWT Multibuffered Serial Peripheral Interface Modules (MibSPI)

TERMINAL		SIGNAL TYPE	RESET PULL STATE	PULL TYPE	DESCRIPTION			
SIGNAL NAME	337 ZWT							
MIBSPI1CLK	F18	I/O	Pullup	Programmable, 20 µA	MibSPI1 clock, or GPIO			
MIBSPI1NCS[0]/MIBSPI1SOMI[1]/MII_TXD[2]/USB1.RCV	R2				MibSPI1 chip select, or GPIO			
MIBSPI1NCS[1]/N2HET1[17]/MII_COL/USB1.SUSPEND	F3							
MIBSPI1NCS[2]/N2HET1[19]/MDIO	G3							
MIBSPI1NCS[3]/N2HET1[21]	J3							
N2HET1[15]/MIBSPI1NCS[4]	N1							
N2HET1[24]/MIBSPI1NCS[5]/MII_RXD[0]/RMII_RXD[0]	P1		Pulldown	Programmable, 20 µA		MibSPI1 chip select, or GPIO		
MIBSPI1NENA/N2HET1[23]/MII_RXD[2]/USB1.VP	G19							
MIBSPI1SIMO[0]	F19				Pullup		Programmable, 20 µA	MibSPI1 enable, or GPIO
N2HET1[8]/MIBSPI1SIMO[1]/MII_TXD[3]/USB1.OverCurrent	E18							MibSPI1 slave-in master-out, or GPIO
MIBSPI1SOMI[0]	G18				Pulldown		Programmable, 20 µA	MibSPI1 slave-in master-out, or GPIO
MIBSPI1NCS[0]/MIBSPI1SOMI[1]/MII_TXD[2]/USB1.RCV	R2							
MIBSPI3CLK	V9	I/O	Pullup	Programmable, 20 µA	MibSPI3 clock, or GPIO			
MIBSPI3NCS[0]/AD2EVT/GIOB[2]/N2HET2_PIN_nDIS	V10				MibSPI3 chip select, or GPIO			
MIBSPI3NCS[1]/N2HET1[25]/MDCLK	V5							
MIBSPI3NCS[2]/I2C_SDA/N2HET1[27]	B2							
MIBSPI3NCS[3]/I2C_SCL/N2HET1[29]	C3							
N2HET1[11]/MIBSPI3NCS[4]/N2HET2[18]/USB2.OverCurrent/USB_FUNC.VBUSI	E3					Pulldown	Programmable, 20 µA	MibSPI3 chip select, or GPIO
MIBSPI3NENA/MIBSPI3NCS[5]/N2HET1[31]	W9							
MIBSPI3NENA/MIBSPI3NCS[5]/N2HET1[31]	W9		Pullup	Programmable, 20 µA	MibSPI3 chip select, or GPIO			
MIBSPI3SIMO[0]	W8				MibSPI3 enable, or GPIO			
MIBSPI3SOMI[0]	V8				MibSPI3 slave-in master-out, or GPIO			
MIBSPI5CLK/DMM_DATA[4]/MII_TXEN/RMII_TXEN	H19				I/O			
MIBSPI5NCS[0]/DMM_DATA[5]	E19		MibSPI5 chip select, or GPIO					
MIBSPI5NCS[1]/DMM_DATA[6]	B6							
MIBSPI5NCS[2]/DMM_DATA[2]	W6							
MIBSPI5NCS[3]/DMM_DATA[3]	T12							
MIBSPI5NENA/DMM_DATA[7]/MII_RXD[3]/USB1.VM	H18	MibSPI5 enable, or GPIO						
MIBSPI5SIMO[0]/DMM_DATA[8]/MII_TXD[1]/RMII_TXD[1]	J19			MibSPI5 slave-in master-out, or GPIO				
MIBSPI5SIMO[1]/DMM_DATA[9]	E16							
MIBSPI5SIMO[2]/DMM_DATA[10]	H17							
MIBSPI5SIMO[3]/DMM_DATA[11]	G17							
MIBSPI5SOMI[0]/DMM_DATA[12]/MII_TXD[0]/RMII_TXD[0]	J18							
MIBSPI5SOMI[1]/DMM_DATA[13]	E17	MibSPI5 slave-in master-out, or GPIO						
MIBSPI5SOMI[2]/DMM_DATA[14]	H16							
MIBSPI5SOMI[3]/DMM_DATA[15]	G16							

4.3.2.10 Ethernet Controller

Table 4-31. ZWT Ethernet Controller: MDIO Interface

TERMINAL		SIGNAL TYPE	RESET PULL STATE	PULL TYPE	DESCRIPTION
SIGNAL NAME	337 ZWT				
MIBSPI3NCS[1]/N2HET1[25]/MDCLK	V5	Output	Pullup	None	Serial clock output
MIBSPI1NCS[2]/N2HET1[19]/MDIO	G3	I/O	Pullup	Fixed, 20 μ A	Serial data input/output

Table 4-32. ZWT Ethernet Controller: Reduced Media Independent Interface (RMII)

TERMINAL		SIGNAL TYPE	RESET PULL STATE	PULL TYPE	DESCRIPTION
SIGNAL NAME	337 ZWT				
N2HET1[12]/MII_CRS/RMII_CRS_DV	B4	Input	Pulldown	Fixed 12 μ A Pulldown	RMII carrier sense and receive data valid
N2HET1[28]/MII_RX_CLK/RMII_REFCLK/MII_RX_AVCLK4	K19				RMII synchronous reference clock for receive, transmit and control interface
AD1EVT/MII_RX_ER/RMII_RX_ER	N19				RMII receive error
N2HET1[24]/MIBSPI1NCS[5]/MII_RXD[0]/RMII_RXD[0]	P1				RMII receive data
N2HET1[26]/MII_RXD[1]/RMII_RXD[1]	A14	Output	Pullup	None	RMII transmit data
MIBSPI5SOMI[0]/DMM_DATA[12]/MII_TXD[0]/RMII_TXD[0]	J18				RMII transmit data
MIBSPI5SIMO[0]/DMM_DATA[8]/MII_TXD[1]/RMII_TXD[1]	J19				RMII transmit data
MIBSPI5CLK/DMM_DATA[4]/MII_TXEN/RMII_TXEN	H19				RMII transmit enable

Table 4-33. ZWT Ethernet Controller: Media Independent Interface (MII)

TERMINAL		SIGNAL TYPE	RESET PULL STATE	PULL TYPE	DESCRIPTION
SIGNAL NAME	337 ZWT				
MIBSPI1NCS[1]/N2HET1[17]/MII_COL/ USB1.SUSPEND	F3	Input	Pullup	None	Collision detect
N2HET1[12]/MII_CRS/RMII_CRS_DV	B4		Pulldown	Fixed 20 μ A Pulldown	Carrier sense and receive data valid
N2HET1[28]/MII_RX_CLK/RMII_REFCLK/MII_RX_AVCLK4	K19	I/O	Pulldown	None	MII output receive clock
N2HET1[30]/MII_RX_DV/USB1.SPEED	B11	Input	Pulldown	Fixed 20 μ A Pulldown	Received data valid
AD1EVT/MII_RX_ER/RMII_RX_ER	N19				Receive error
N2HET1[28]/MII_RX_CLK/RMII_REFCLK/MII_RX_AVCLK4	K19	I/O	Pulldown	Fixed 20 μ A Pulldown	Receive clock
N2HET1[24]/MIBSPI1NCS[5]/MII_RXD[0]/RMII_RXD[0]	P1	Input			Pullup
N2HET1[26]/MII_RXD[1]/RMII_RXD[1]	A14				
MIBSPI1NENA/N2HET1[23]/MII_RXD[2]/ USB1.VP	G19				
MIBSPI5NENA/DMM_DATA[7]/MII_RXD[3]/ USB1.VM	H18	I/O	Pulldown	None	MII output transmit clock
N2HET1[10]/MII_TX_CLK/USB1.TXEN/ MII_TX_AVCLK4	D19				Transmit clock
N2HET1[10]/MII_TX_CLK/USB1.TXEN /MII_TX_AVCLK4	D19	Output	Pullup	None	Transmit data
MIBSPI5SOMI[0]/DMM_DATA[12]/MII_TXD[0]/RMII_TXD[0]	J18				
MIBSPI5SIMO[0]/DMM_DATA[8]/MII_TXD[1]/RMII_TXD[1]	J19				
MIBSPI1NCS[0]/MIBSPI1SOMI[1]/MII_TXD[2]/ USB1.RCV	R2				
N2HET1[8]/MIBSPI1SIMO[1]/MII_TXD[3]/ USB1.OverCurrent	E18				
MIBSPI5CLK/DMM_DATA[4]/MII_TXEN/RMII_TXEN	H19	Pulldown	None	Transmit enable	

4.3.2.11 USB Host and Device Port Controller Interface

The USB Host Controller includes a root hub with two ports. USB1 pins are for Root Hub Port 0. USB2 pins are for Root Hub Port 1.

Table 4-34. ZWT USB Host Port Controller Interface (USB1, USB2)

TERMINAL		SIGNAL TYPE	RESET PULL STATE	PULL TYPE	DESCRIPTION
SIGNAL NAME	337 ZWT				
N2HET1[8]/MIBSPI1SIMO[1]/MII_TXD[3]/ USB1.OVERCURRENT	E18	Input	Pulldown	Fixed, 20 µA	Active low input, asserted during overcurrent condition from USB power switch
MIBSPI1NCS[0]/MIBSPI1SOMI[1]/MII_TXD[2]/ USB1.RCV	R2		Pullup	Fixed, 20 µA	USB Receive Data, converted from differential (D+/D- to single ended by transceiver).
MIBSPI5NENA/DMM_DATA[7]/MII_RXD[3]/ USB1.VM	H18				Single-ended D- Input, driven by transceiver
MIBSPI1NENA/N2HET1[23]/MII_RXD[2]/ USB1.VP	G19				Single-ended D+ Input, driven by transceiver
GIOB[1]/ USB1.PORTPOWER	K2	Output	Pulldown	None	Active-high output enable for controlling an external USB power switch
N2HET1[30]/MII_RX_DV/ USB1.SPEED	B11				Transmit speed to USB port transceiver. 0 = Low Speed 1 = Full Speed
MIBSPI1NCS[1]/N2HET1[17]/MII_COL/ USB1.SUSPEND	F3		Pullup	None	This signal indicates the state of the port, active or suspend. 0 = Active 1 = Suspend
GIOB[0]/ USB1.TXDAT	M2		Pulldown	None	Single-Ended USB Data Output to USB Transceiver. Use in combination with USB1.TXSE0
N2HET1[10]/MII_TX_CLK/ USB1.TXEN / MII_TX_AVCLK4	D19				Active-low output transmit enable to port transceiver
N2HET1[14]/ USB1.TXSE0	A11				Active High Output – Instructs Transceiver to transmit single-ended zero
N2HET1[11]/MIBSPI3NCS[4]/N2HET2[18]/ USB2.OVERCURRENT /USB_FUNC.VBUSI	E3		Input	Pullup	Fixed, 20 µA
GIOB[3]/ USB2.RCV /USB_FUNC.RXDI	W10	Pulldown		Fixed, 20 µA	Receive data from USB port transceiver. This signal is generated from D+, D- differential lines of the USB cable.
GIOA[1]/ USB2.VM /USB_FUNC.RXDMI	C2				Single-ended D- Input, driven by transceiver
GIOA[0]/ USB2.VP /USB_FUNC.RXDPI	A5				Single-ended D+ Input, driven by transceiver.

Table 4-34. ZWT USB Host Port Controller Interface (USB1, USB2) (continued)

TERMINAL		SIGNAL TYPE	RESET PULL STATE	PULL TYPE	DESCRIPTION
SIGNAL NAME	337 ZWT				
N2HET1[7]/USB2.PORTPOWER/ USB_FUNC.GZO/N2HET2[14]	T1	Output	Pulldown	None	Active-high output enable for controlling an external USB power switch
N2HET1[3]/SPI4NCS[0]/USB2.SPEED/ USB_FUNC.PUENON/N2HET2[10]	U1				Transmit speed to USB port transceiver. 0 = Low Speed 1 = Full Speed.
N2HET1[9]/N2HET2[16]/USB2.SUSPEND/ USB_FUNC.SUSPENDO	V7				This signal indicates the state of the port, active or suspend. 0 = Active 1 = Suspend
GIOA[2]/USB2.TXDAT/USB_FUNC.TXDO/N2HET2[0]	C1				Single-Ended USB Data Output to USB Transceiver. Use in combination with USB2.TXSE0
N2HET1[1]/SPI4NENA/USB2.TXEN/ USB_FUNC.PUENO/N2HET2[8]	V2				Active-low output; transmit enable to port transceiver
N2HET1[22]/USB2.TXSE0/USB_FUNC.SE00	B3				Active High Output – Instructs Transceiver to transmit single-ended zero.r

Table 4-35. ZWT USB Device Port Controller Interface (USB_FUNC)

TERMINAL		SIGNAL TYPE	RESET PULL STATE	PULL TYPE	DESCRIPTION
SIGNAL NAME	337 ZWT				
N2HET1[7]/USB2.PortPower/USB_FUNC.GZO/N2HET2[14]	T1	Output	Pulldown	None	USB device transmit enable to port transceiver
N2HET1[1]/SPI4NENA/USB2.TXEN/USB_FUNC.PUENO/ N2HET2[8]	V2				Pull-up enable, allows for software-programmable USB device connect/disconnect
N2HET1[3]/SPI4NCS[0]/USB2.SPEED/USB_FUNC.PUENON/ N2HET2[10]	U1				PUENO inverted
GIOB[3]/USB2.RCV/USB_FUNC.RXDI	W10	Input	Pulldown	Fixed 20 μ A Pullup	USB Receive Data, converted from differential (D+/D– to single ended by transceiver).
GIOA[1]/USB2.VM/USB_FUNC.RXDMI	C2				Single-ended D– Input, driven by transceiver
GIOA[0]/USB2.VP/USB_FUNC.RXDPI	A5				Single-ended D+ Input, driven by transceiver
N2HET1[22]/USB2.TXSE0/USB_FUNC.SE00	B3	Output	Pulldown	None	Active-high output – Instructs Transceiver to transmit single-ended zero.
N2HET1[9]/N2HET2[16]/USB2.SUSPEND/USB_FUNC.SUSPENDO	V7				Active-high output – USB device suspend output. This function is asserted when the USB bus has detected an idle mode during 5 ms.
GIOA[2]/USB2.TXDAT/USB_FUNC.TXDO/N2HET2[0]	C1				Single Ended USB Data Output to USB Transceiver. Use in combination with USB_FUNC.SE00
N2HET1[11]/MIBSPI3NCS[4]/N2HET2[18]/ USB2.OverCurrent/USB_FUNC.VBUSI	E3	Input	Pulldown	Fixed 20 μ A Pullup	Must be pulled up or down to reflect the state of power on the VBUS terminal of the USB device connector. This terminal is not 5V tolerant.

4.3.2.12 External Memory Interface (EMIF)

Table 4-36. External Memory Interface (EMIF)

TERMINAL		337 ZWT	SIGNAL TYPE	RESET PULL STATE	PULL TYPE	DESCRIPTION
SIGNAL NAME						
EMIF_CKE	L3		Output		None	EMIF Clock Enable
EMIF_CLK	K3		I/O	Pulldown	None	EMIF clock. This is an output signal in functional mode. It is gated off by default, so that the signal is tri-stated. PINMUX29[8] must be cleared to enable this output.
ETMDATA[13]/EMIF_nOE	E12			Pulldown	None	EMIF Output Enable
EMIF_nWAIT	P3		I/O	Pullup	Fixed 20 µA Pullup	EMIF Extended Wait Signal
EMIF_nWE	D17		Output	Pullup		EMIF Write Enable.
EMIF_nCAS	R4		Output			EMIF column address strobe
EMIF_nRAS	R3		Output			EMIF row address strobe
EMIF_nCS[0]/RTP_DATA[15]/N2HET2[7]	N17		Output	Pulldown	None	EMIF chip select, SDRAM
EMIF_nCS[2]	L17		Output	Pullup		EMIF chip selects, asynchronous This applies to chip selects 2, 3, and 4
EMIF_nCS[3]/RTP_DATA[14]/N2HET2[9]	K17		Output	Pulldown		
EMIF_nCS[4]/RTP_DATA[7]	M17		Output	Pullup		
ETMDATA[15]/EMIF_nDQM[0]	E10		Output	Pulldown	None	EMIF Data Mask or Write Strobe.
ETMDATA[14]/EMIF_nDQM[1]	E11		Output			Data mask for SDRAM devices, write strobe for connected asynchronous devices.
ETMDATA[12]/EMIF_BA[0]	E13		Output			EMIF bank address or address line
EMIF_BA[1]/N2HET2[5]	D16		Output			EMIF bank address or address line
EMIF_ADDR[0]/N2HET2[1]	D4		Output			EMIF address
EMIF_ADDR[1]/N2HET2[3]	D5		Output			
ETMDATA[11]/EMIF_ADDR[2]	E6		Output			
ETMDATA[10]/EMIF_ADDR[3]	E7		Output			
ETMDATA[9]/EMIF_ADDR[4]	E8		Output			
ETMDATA[8]/EMIF_ADDR[5]	E9		Output			
EMIF_ADDR[6]/RTP_DATA[13]/N2HET2[11]	C4		Output			
EMIF_ADDR[7]/RTP_DATA[12]/N2HET2[13]	C5		Output			
EMIF_ADDR[8]/RTP_DATA[11]/N2HET2[15]	C6		Output			
EMIF_ADDR[9]/RTP_DATA[10]	C7		Output			
EMIF_ADDR[10]/RTP_DATA[9]	C8		Output			
EMIF_ADDR[11]/RTP_DATA[8]	C9		Output			
EMIF_ADDR[12]/RTP_DATA[6]	C10		Output			
EMIF_ADDR[13]/RTP_DATA[5]	C11		Output			
EMIF_ADDR[14]/RTP_DATA[4]	C12		Output			
EMIF_ADDR[15]/RTP_DATA[3]	C13		Output			
EMIF_ADDR[16]/RTP_DATA[2]	D14		Output			
EMIF_ADDR[17]/RTP_DATA[1]	C14		Output	Pulldown		
EMIF_ADDR[18]/RTP_DATA[0]	D15		Output			
EMIF_ADDR[19]/RTP_nENA	C15		Output			
EMIF_ADDR[20]/RTP_nSYNC	C16		Output			
EMIF_ADDR[21]/RTP_CLK	C17		Output			

Table 4-36. External Memory Interface (EMIF) (continued)

TERMINAL		SIGNAL TYPE	RESET PULL STATE	PULL TYPE	DESCRIPTION
SIGNAL NAME	337 ZWT				
ETMDATA[16]/EMIF_DATA[0]	K15	I/O	Pulldown	Fixed 20 μ A Pullup	EMIF Data
ETMDATA[17]/EMIF_DATA[1]	L15	I/O			
ETMDATA[18]/EMIF_DATA[2]	M15	I/O			
ETMDATA[19]/EMIF_DATA[3]	N15	I/O			
ETMDATA[20]/EMIF_DATA[4]	E5	I/O			
ETMDATA[21]/EMIF_DATA[5]	F5	I/O			
ETMDATA[22]/EMIF_DATA[6]	G5	I/O			
ETMDATA[23]/EMIF_DATA[7]	K5	I/O			
ETMDATA[24]/EMIF_DATA[8]	L5	I/O			
ETMDATA[25]/EMIF_DATA[9]	M5	I/O			
ETMDATA[26]/EMIF_DATA[10]	N5	I/O			
ETMDATA[27]/EMIF_DATA[11]	P5	I/O			
ETMDATA[28]/EMIF_DATA[12]	R5	I/O			
ETMDATA[29]/EMIF_DATA[13]	R6	I/O			
ETMDATA[30]/EMIF_DATA[14]	R7	I/O			
ETMDATA[31]/EMIF_DATA[15]	R8	I/O			

4.3.2.13 Embedded Trace Macrocell for Cortex-R4F CPU (ETM-R4F)

Table 4-37. Embedded Trace Macrocell for Cortex-R4F CPU (ETM-R4F)

TERMINAL		SIGNAL TYPE	RESET PULL STATE	PULL TYPE	DESCRIPTION
SIGNAL NAME	337 ZWT				
ETMTRACECLKIN/EXTCLKIN2	R9	Input	Pulldown	Fixed 20 μ A Pullup	ETM Trace Clock Input
ETMTRACECLKOUT	R10	Output	Pulldown	None	ETM Trace Clock Output
ETMTRACECTL	R11				ETM trace control
ETMDATA[0]	R12				ETM data
ETMDATA[1]	R13				
ETMDATA[2]	J15				
ETMDATA[3]	H15				
ETMDATA[4]	G15				
ETMDATA[5]	F15				
ETMDATA[6]	E15				
ETMDATA[7]	E14				
ETMDATA[8]/EMIF_ADDR[5]	E9				
ETMDATA[9]/EMIF_ADDR[4]	E8				
ETMDATA[10]/EMIF_ADDR[3]	E7				
ETMDATA[11]/EMIF_ADDR[2]	E6				
ETMDATA[12]/EMIF_BA[0]	E13				
ETMDATA[13]/EMIF_nOE	E12				
ETMDATA[14]/EMIF_nDQM[1]	E11				
ETMDATA[15]/EMIF_nDQM[0]	E10				
ETMDATA[16]/EMIF_DATA[0]	K15				
ETMDATA[17]/EMIF_DATA[1]	L15				
ETMDATA[18]/EMIF_DATA[2]	M15				
ETMDATA[19]/EMIF_DATA[3]	N15				
ETMDATA[20]/EMIF_DATA[4]	E5				
ETMDATA[21]/EMIF_DATA[5]	F5				
ETMDATA[22]/EMIF_DATA[6]	G5				
ETMDATA[23]/EMIF_DATA[7]	K5				
ETMDATA[24]/EMIF_DATA[8]	L5				
ETMDATA[25]/EMIF_DATA[9]	M5				
ETMDATA[26]/EMIF_DATA[10]	N5				
ETMDATA[27]/EMIF_DATA[11]	P5				
ETMDATA[28]/EMIF_DATA[12]	R5				
ETMDATA[29]/EMIF_DATA[13]	R6				
ETMDATA[30]/EMIF_DATA[14]	R7				
ETMDATA[31]/EMIF_DATA[15]	R8				

4.3.2.14 RAM Trace Port (RTP)

Table 4-38. RAM Trace Port (RTP)

TERMINAL		SIGNAL TYPE	RESET PULL STATE	PULL TYPE	DESCRIPTION
SIGNAL NAME	337 ZWT				
EMIF_ADDR[21]/RTP_CLK	C17	I/O			RTP packet clock, or GPIO
EMIF_ADDR[19]/RTP_nENA	C15	I/O			RTP packet handshake, or GPIO
EMIF_ADDR[20]/RTP_nSYNC	C16	I/O			RTP synchronization, or GPIO
EMIF_ADDR[18]/RTP_DATA[0]	D15	I/O	Pulldown	Programmable, 20 μ A	RTP packet data, or GPIO
EMIF_ADDR[17]/RTP_DATA[1]	C14				
EMIF_ADDR[16]/RTP_DATA[2]	D14				
EMIF_ADDR[15]/RTP_DATA[3]	C13				
EMIF_ADDR[14]/RTP_DATA[4]	C12				
EMIF_ADDR[13]/RTP_DATA[5]	C11				
EMIF_ADDR[12]/RTP_DATA[6]	C10				
EMIF_nCS[4]/RTP_DATA[7]	M17				
EMIF_ADDR[11]/RTP_DATA[8]	C9				
EMIF_ADDR[10]/RTP_DATA[9]	C8				
EMIF_ADDR[9]/RTP_DATA[10]	C7	Pulldown	Programmable, 20 μ A		
EMIF_ADDR[8]/RTP_DATA[11]/N2HET2[15]	C6				
EMIF_ADDR[7]/RTP_DATA[12]/N2HET2[13]	C5				
EMIF_ADDR[6]/RTP_DATA[13]/N2HET2[11]	C4				
EMIF_nCS[0]/RTP_DATA[15]/N2HET2[7]	N17				
EMIF_nCS[3]/RTP_DATA[14]/N2HET2[9]	K17				

4.3.2.15 Data Modification Module (DMM)

Table 4-39. Data Modification Module (DMM)

TERMINAL		SIGNAL TYPE	RESET PULL STATE	PULL TYPE	DESCRIPTION
SIGNAL NAME	337 ZWT				
DMM_CLK	F17	I/O	Pullup	Programmable, 20 µA	DMM clock, or GPIO
DMM_nENA	F16				DMM handshake, or GPIO
DMM_SYNC	J16				DMM synchronization, or GPIO
DMM_DATA[0]	L19				DMM data, or GPIO
DMM_DATA[1]	L18				
MIBSPI5NCS[2]/DMM_DATA[2]	W6				
MIBSPI5NCS[3]/DMM_DATA[3]	T12				
MIBSPI5CLK/DMM_DATA[4]/MII_TXEN/RMII_TXEN	H19				
MIBSPI5NCS[0]/DMM_DATA[5]	E19				
MIBSPI5NCS[1]/DMM_DATA[6]	B6				
MIBSPI5NENA/DMM_DATA[7]/MII_RXD[3]/USB1.VM	H18				
MIBSPI5SIMO[0]/DMM_DATA[8]/MII_TXD[1]/RMII_TXD[1]	J19				
MIBSPI5SIMO[1]/DMM_DATA[9]	E16				
MIBSPI5SIMO[2]/DMM_DATA[10]	H17				
MIBSPI5SIMO[3]/DMM_DATA[11]	G17				
MIBSPI5SOMI[0]/DMM_DATA[12]/MII_TXD[0]/RMII_TXD[0]	J18				
MIBSPI5SOMI[1]/DMM_DATA[13]	E17				
MIBSPI5SOMI[2]/DMM_DATA[14]	H16				
MIBSPI5SOMI[3]/DMM_DATA[15]	G16				

4.3.2.16 System Module Interface

Table 4-40. ZWT System Module Interface

TERMINAL		SIGNAL TYPE	RESET PULL STATE	PULL TYPE	DESCRIPTION
SIGNAL NAME	337 ZWT				
nPORRST	W7	Input	Pulldown	Fixed 100 μ A Pulldown	Power-on reset, cold reset External power supply monitor circuitry must drive nPORRST low when any of the supplies to the microcontroller fall out of the specified range. This terminal has a glitch filter. See Section 6.8 .
nRST	B17	I/O	Pullup	Fixed 100 μ A Pullup	System reset, warm reset, bidirectional. The internal circuitry indicates any reset condition by driving nRST low. The external circuitry can assert a system reset by driving nRST low. To ensure that an external reset is not arbitrarily generated, TI recommends that an external pullup resistor is connected to this terminal. This terminal has a glitch filter. See Section 6.8 .
nERROR	B14	I/O	Pulldown	Fixed 20 μ A Pulldown	ESM Error Signal Indicates error of high severity. See Section 6.18 .

4.3.2.17 Clock Inputs and Outputs

Table 4-41. ZWT Clock Inputs and Outputs

TERMINAL		SIGNAL TYPE	RESET PULL STATE	PULL TYPE	DESCRIPTION
SIGNAL NAME	337 ZWT				
OSCIN	K1	Input	N/A	None	From external crystal/resonator, or external clock input
KELVIN_GND	L2	Input			Kelvin ground for oscillator
OSCOU	L1	Output			To external crystal/resonator
ECLK	A12	I/O	Pulldown	Programmable, 20 μ A	External prescaled clock output, or GIO.
GIOA[5]/EXTCLKIN/N2HET1_PIN_nDIS	B5	Input	Pulldown	Fixed 20 μ A Pulldown	External clock input #1
ETMTRACECLKIN/EXTCLKIN2	R9	Input			External clock input #2
VCCPLL	P11	1.2-V Power	N/A	None	Dedicated core supply for PLLs

4.3.2.18 Test and Debug Modules Interface

Table 4-42. ZWT Test and Debug Modules Interface

TERMINAL		SIGNAL TYPE	RESET PULL STATE	PULL TYPE	DESCRIPTION
SIGNAL NAME	337 ZWT				
TEST	U2	I/O	Pulldown	Fixed 100 μ A Pulldown	Test enable. This terminal must be connected to ground directly or via a pulldown resistor.
nTRST	D18	Input			JTAG test hardware reset
RTCK	A16	Output	N/A	None	JTAG return test clock
TCK	B18	Input	Pulldown	Fixed 100 μ A Pulldown	JTAG test clock
TDI	A17	I/O	Pullup	Fixed 100 μ A Pullup	JTAG test data in
TDO	C18	Output	100 μ A Pulldown	None	JTAG test data out
TMS	C19	I/O	Pullup	Fixed 100 μ A Pullup	JTAG test select

4.3.2.19 Flash Supply and Test Pads

Table 4-43. ZWT Flash Supply and Test Pads

TERMINAL		SIGNAL TYPE	RESET PULL STATE	PULL TYPE	DESCRIPTION
SIGNAL NAME	337 ZWT				
VCCP	F8	3.3-V Power	N/A	None	Flash pump supply
FLTP1	J5	–	N/A	None	Flash test pads. These terminals are reserved for TI use only. For proper operation these terminals must connect only to a test pad or not be connected at all [no connect (NC)].
FLTP2	H5				

4.3.2.20 Reserved

Table 4-44. Reserved

TERMINAL		SIGNAL TYPE	RESET PULL STATE	PULL TYPE	DESCRIPTION
SIGNAL NAME	337 ZWT				
Reserved	A15	–	N/A	None	Reserved. These balls are connected to internal logic but are not outputs nor do they have internal pulls. They are subject to ± 1 μ A leakage current.
Reserved	B15	–	N/A	None	
Reserved	B16	–	N/A	None	
Reserved	A8	–	N/A	None	
Reserved	B8	–	N/A	None	
Reserved	B9	–	N/A	None	

4.3.2.21 No Connects
Table 4-45. No Connects

TERMINAL		SIGNAL TYPE	RESET PULL STATE	PULL TYPE	DESCRIPTION
SIGNAL NAME	337 ZWT				
NC	D6	–	N/A	None	No Connects. These balls are not connected to any internal logic and can be connected to the PCB ground without affecting the functionality of the device.
NC	D7	–	N/A	None	
NC	D8	–	N/A	None	
NC	D9	–	N/A	None	
NC	D10	–	N/A	None	
NC	D11	–	N/A	None	
NC	D12	–	N/A	None	
NC	D13	–	N/A	None	
NC	E4	–	N/A	None	
NC	F4	–	N/A	None	
NC	G4	–	N/A	None	
NC	K4	–	N/A	None	
NC	K16	–	N/A	None	
NC	L4	–	N/A	None	
NC	L16	–	N/A	None	
NC	M4	–	N/A	None	
NC	M16	–	N/A	None	
NC	N4	–	N/A	None	
NC	N16	–	N/A	None	
NC	N18	–	N/A	None	
NC	P4	–	N/A	None	
NC	P15	–	N/A	None	
NC	P16	–	N/A	None	
NC	P17	–	N/A	None	
NC	R1	–	N/A	None	
NC	R14	–	N/A	None	
NC	R15	–	N/A	None	
NC	T2	–	N/A	None	
NC	T3	–	N/A	None	
NC	T4	–	N/A	None	
NC	T5	–	N/A	None	
NC	T6	–	N/A	None	
NC	T7	–	N/A	None	
NC	T8	–	N/A	None	
NC	T9	–	N/A	None	
NC	T10	–	N/A	None	
NC	T11	–	N/A	None	
NC	T13	–	N/A	None	
NC	T14	–	N/A	None	
NC	U3	–	N/A	None	
NC	U4	–	N/A	None	

Table 4-45. No Connects (continued)

TERMINAL		SIGNAL TYPE	RESET PULL STATE	PULL TYPE	DESCRIPTION
SIGNAL NAME	337 ZWT				
NC	U5	–	N/A	None	No Connects. These balls are not connected to any internal logic and can be connected to the PCB ground without affecting the functionality of the device.
NC	U6	–	N/A	None	
NC	U7	–	N/A	None	
NC	U8	–	N/A	None	
NC	U9	–	N/A	None	
NC	U10	–	N/A	None	
NC	U11	–	N/A	None	
NC	U12	–	N/A	None	
NC	V3	–	N/A	None	
NC	V4	–	N/A	None	
NC	V11	–	N/A	None	
NC	V12	–	N/A	None	
NC	W4	–	N/A	None	
NC	W11	–	N/A	None	
NC	W12	–	N/A	None	
NC	W13	–	N/A	None	

4.3.2.22 Supply for Core Logic: 1.2-V Nominal

Table 4-46. ZWT Supply for Core Logic: 1.2-V Nominal

TERMINAL		SIGNAL TYPE	RESET PULL STATE	PULL TYPE	DESCRIPTION
SIGNAL NAME	337 ZWT				
VCC	F9	1.2-V Power	N/A	None	Core supply
VCC	F10				
VCC	H10				
VCC	J14				
VCC	K6				
VCC	K8				
VCC	K12				
VCC	K14				
VCC	L6				
VCC	M10				
VCC	P10				

4.3.2.23 Supply for I/O Cells: 3.3-V Nominal
Table 4-47. ZWT Supply for I/O Cells: 3.3-V Nominal

TERMINAL		SIGNAL TYPE	RESET PULL STATE	PULL TYPE	DESCRIPTION
SIGNAL NAME	337 ZWT				
VCCIO	F6	3.3-V Power	N/A	None	Operating supply for I/Os
VCCIO	F7				
VCCIO	F11				
VCCIO	F12				
VCCIO	F13				
VCCIO	F14				
VCCIO	G6				
VCCIO	G14				
VCCIO	H6				
VCCIO	H14				
VCCIO	J6				
VCCIO	L14				
VCCIO	M6				
VCCIO	M14				
VCCIO	N6				
VCCIO	N14				
VCCIO	P6				
VCCIO	P7				
VCCIO	P8				
VCCIO	P9				
VCCIO	P12				
VCCIO	P13				
VCCIO	P14				

4.3.2.24 Ground Reference for All Supplies Except VCCAD

Table 4-48. ZWT Ground Reference for All Supplies Except VCCAD

TERMINAL		SIGNAL TYPE	RESET PULL STATE	PULL TYPE	DESCRIPTION
SIGNAL NAME	337 ZWT				
VSS	A1	Ground	N/A	None	Ground reference
VSS	A2				
VSS	A18				
VSS	A19				
VSS	B1				
VSS	B19				
VSS	H8				
VSS	H9				
VSS	H11				
VSS	H12				
VSS	J8				
VSS	J9				
VSS	J10				
VSS	J11				
VSS	J12				
VSS	K9				
VSS	K10				
VSS	K11				
VSS	L8				
VSS	L9				
VSS	L10				
VSS	L11				
VSS	L12				
VSS	M8				
VSS	M9				
VSS	M11				
VSS	M12				
VSS	V1				
VSS	W1				
VSS	W2				

5 Specifications

5.1 Absolute Maximum Ratings ⁽¹⁾

Over Operating Free-Air Temperature Range

		MIN	MAX	UNIT
Supply voltage	$V_{CC}^{(2)}$	-0.3	1.43	V
	$V_{CCIO}, V_{CCP}^{(2)}$	-0.3	4.6	
	V_{CCAD}	-0.3	6.25	
Input voltage	All input pins	-0.3	4.6	V
	ADC input pins	-0.3	6.25	
Input clamp current	I_{IK} ($V_I < 0$ or $V_I > V_{CCIO}$) All pins, except AD1IN[23:0] and AD2IN[15:0]	-20	20	mA
	I_{IK} ($V_I < 0$ or $V_I > V_{CCAD}$) AD1IN[23:0] and AD2IN[15:0]	-10	10	
	Total	-40	40	mA
Operating free-air temperature, T_A :		-40	105	°C
Operating junction temperature, T_J :		-40	130	°C
Storage temperature, T_{stg}		-65	150	°C

- Stresses beyond those listed under *Absolute Maximum Ratings* may cause permanent damage to the device. These are stress ratings only, and functional operation of the device at these or any other conditions beyond those indicated under *Recommended Operating Conditions* is not implied. Exposure to absolute-maximum-rated conditions for extended periods may affect device reliability.
- Maximum-rated conditions for extended periods may affect device reliability. All voltage values are with respect to their associated grounds.

5.2 ESD Ratings

			VALUE	UNIT
V_{ESD}	Electrostatic discharge (ESD) performance:	Human body model (HBM), per ANSI/ESDA/JEDEC JS001 ⁽¹⁾	±2	kV
		Charged device model (CDM), per JESD22-C101 ⁽²⁾	±250	V

- JEDEC document JEP155 states that 500-V HBM allows safe manufacturing with a standard ESD control process.
- JEDEC document JEP157 states that 250-V CDM allows safe manufacturing with a standard ESD control process.

5.3 Power-On Hours (POH) ⁽¹⁾⁽²⁾

NOMINAL CORE VOLTAGE (V_{CC})	JUNCTION TEMPERATURE (T_J)	LIFETIME POH
1.2	105°C	100K

- This information is provided solely for your convenience and does not extend or modify the warranty provided under TI's standard terms and conditions for TI semiconductor products.
- To avoid significant degradation, the device power-on hours (POH) must be limited to those specified in this table. To convert to equivalent POH for a specific temperature profile, see the *Calculating Equivalent Power-on-Hours for Hercules Safety MCUs* Application Report ([SPNA207](#)).

5.4 Recommended Operating Conditions⁽¹⁾

		MIN	NOM	MAX	UNIT
V _{CC}	Digital logic supply voltage (Core)	1.14	1.2	1.32	V
V _{CCPLL}	PLL Supply Voltage	1.14	1.2	1.32	V
V _{CCIO}	Digital logic supply voltage (I/O)	3	3.3	3.6	V
V _{CCAD}	MibADC supply voltage	3	3.3/5.0	5.25	V
V _{CCP}	Flash pump supply voltage	3	3.3	3.6	V
V _{SS}	Digital logic supply ground	0			V
V _{SSAD}	MibADC supply ground	-0.1	0.1		V
V _{ADREFHI}	A-to-D high-voltage reference source	V _{SSAD}		V _{CCAD}	V
V _{ADREFLO}	A-to-D low-voltage reference source	V _{SSAD}		V _{CCAD}	V
V _{SLEW}	Maximum positive slew rate for V _{CCIO} , V _{CCAD} and V _{CCP} supplies	1			V/μs
T _A	Operating free-air temperature	105			°C
T _J	Operating junction temperature ⁽²⁾	130			°C

(1) All voltages are with respect to V_{SS}, except V_{CCAD}, which is with respect to V_{SSAD}

(2) Reliability data is based upon a temperature profile that is equivalent to 100,000 power-on hours at 105°C junction temperature.

5.5 Switching Characteristics for Clock Domains

Over Recommended Operating Conditions

Table 5-1. Clock Domain Timing Specifications

PARAMETER	DESCRIPTION	CONDITIONS	MIN	MAX	UNIT
f _{HCLK}	HCLK - System clock frequency	Pipeline mode enabled		220	MHz
		Pipeline mode disabled		55	MHz
f _{GCLK}	GCLK - CPU clock frequency			f _{HCLK}	MHz
f _{VCLK}	VCLK - Primary peripheral clock frequency			110	MHz
f _{VCLK2}	VCLK2 - Secondary peripheral clock frequency			110	MHz
f _{VCLK3}	VCLK3 - Secondary peripheral clock frequency			110	MHz
f _{VCLKA1}	VCLKA1 - Primary asynchronous peripheral clock frequency			100	MHz
f _{VCLKA3}	VCLKA3 - Primary asynchronous peripheral clock frequency			48	MHz
f _{VCLKA4}	VCLKA4 - Secondary asynchronous peripheral clock frequency			50	MHz
f _{RTICKL}	RTICKL - clock frequency			f _{VCLK}	MHz

5.6 Wait States Required

RAM

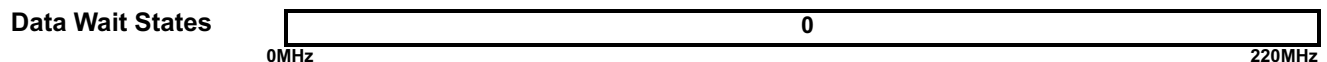
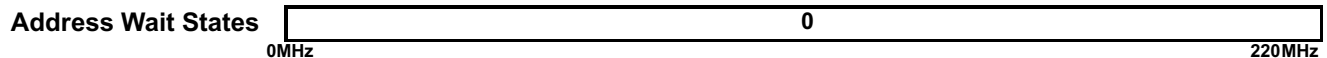

Flash

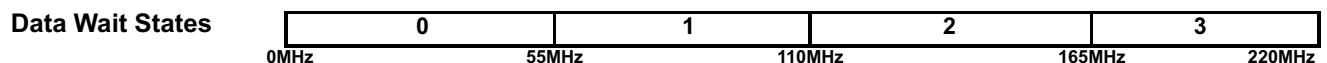
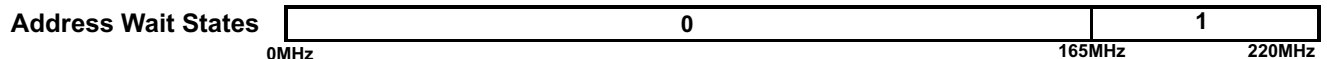

Figure 5-1. Wait States Scheme

As shown in Figure 5-1, the TCM RAM can support program and data fetches at full CPU speed without any address or data wait states required.

The TCM flash can support zero address and data wait states up to a CPU speed of 55 MHz in nonpipelined mode. The flash supports a maximum CPU clock speed of 220 MHz in pipelined mode with one address wait state and three data wait states.

The flash wrapper defaults to nonpipelined mode with zero address wait state and one random-read data wait state.

5.7 Power Consumption

Over Recommended Operating Conditions

PARAMETER		TEST CONDITIONS	MIN	TYP	MAX	UNIT
I _{CC} , I _{CCPLL}	V _{CC} Digital supply current (operating mode)	f _{HCLK} = 220 MHz f _{VCLK} = 110 MHz, Flash in pipelined mode, V _{CCmax}		260 ⁽¹⁾	420 ⁽²⁾	mA
	V _{CC} Digital supply current (LBIST mode)	LBIST clock rate = 110 MHz			690 ⁽³⁾⁽⁴⁾	
	V _{CC} Digital supply current (PBIST mode)	PBIST ROM clock frequency = 110 MHz			690 ⁽³⁾⁽⁴⁾	
I _{CCIO}	V _{CCIO} supply current (operating mode)	No DC load, V _{CCmax}			10	mA
I _{CCAD}	V _{CCAD} supply current (operating mode)	Single ADC operational, V _{CCADmax}			15	mA
		Both ADCs operational, V _{CCADmax}			30	
I _{ADREFHI}	AD _{REFHI} supply current (operating mode)	Single ADC operational, AD _{REFHI} max			3	mA
		Both ADCs operational, AD _{REFHI} max			6	
I _{CCP}	V _{CCP} pump supply current	Read from 1 bank and program or erase another bank, V _{CCPmax}			60	mA

- (1) The typical value is the average current for the nominal process corner and junction temperature of 25°C.
- (2) The maximum I_{CC} value can be derated
- linearly with voltage
 - by 1 ma/MHz for lower operating frequency when f_{HCLK} = 2 * f_{VCLK}
 - for lower junction temperature by the equation below where T_{JK} is the junction temperature in Kelvin and the result is in milliamperes.

$$166 - 0.15 e^{0.0174 T_{JK}}$$
- (3) The maximum I_{CC} value can be derated
- linearly with voltage
 - by 1.7 ma/MHz for lower operating frequency when f_{HCLK} = 2 * f_{VCLK}
 - for lower junction temperature by the equation below where T_{JK} is the junction temperature in Kelvin and the result is in milliamperes.

$$166 - 0.15 e^{0.0174 T_{JK}}$$
- (4) LBIST and PBIST currents are for a short duration, typically less than 10 ms. They are usually ignored for thermal calculations for the device and the voltage regulator

5.8 Input/Output Electrical Characteristics⁽¹⁾

Over Recommended Operating Conditions

PARAMETER			TEST CONDITIONS	MIN	TYP	MAX	UNIT
V_{hys}	Input hysteresis	All inputs		180			mV
V_{IL}	Low-level input voltage	All inputs ⁽²⁾		-0.3		0.8	V
V_{IH}	High-level input voltage	All inputs ⁽²⁾		2		$V_{CCIO} + 0.3$	V
V_{OL}	Low-level output voltage		$I_{OL} = I_{OLmax}$			$0.2 V_{CCIO}$	V
			$I_{OL} = 50 \mu A$, standard output mode			0.2	
			$I_{OL} = 50 \mu A$, low-EMI output mode (see Section 5.13)			$0.2 V_{CCIO}$	
V_{OH}	High-level output voltage		$I_{OH} = I_{OHmax}$			$0.8 V_{CCIO}$	V
			$I_{OH} = 50 \mu A$, standard output mode			$V_{CCIO} - 0.3$	
			$I_{OH} = 50 \mu A$, low-EMI output mode (see Section 5.13)			$0.8 V_{CCIO}$	
I_{IC}	Input clamp current (I/O pins)		$V_I < V_{SSIO} - 0.3$ or $V_I > V_{CCIO} + 0.3$	-3.5		3.5	mA
I_I	Input current (I/O pins)	I_{IH} Pulldown 20 μA	$V_I = V_{CCIO}$	5		40	μA
		I_{IH} Pulldown 100 μA	$V_I = V_{CCIO}$	40		195	
		I_{IL} Pullup 20 μA	$V_I = V_{SS}$	-40		-5	
		I_{IL} Pullup 100 μA	$V_I = V_{SS}$	-195		-40	
		All other pins	No pullup or pulldown	-1		1	
C_I	Input capacitance					2	pF
C_O	Output capacitance					3	pF

(1) Source currents (out of the device) are negative while sink currents (into the device) are positive.

(2) This does not apply to the nPORRST pin.

5.9 Thermal Resistance Characteristics

Table 5-2 shows the thermal resistance characteristics for the QFP - PGE mechanical package.

Table 5-3 shows the thermal resistance characteristics for the BGA - ZWT mechanical package.

Table 5-2. Thermal Resistance Characteristics (PGE Package)

		°C / W
$R\theta_{JA}$	Junction-to-free air thermal resistance, Still air using JEDEC 2S2P test board	39
$R\theta_{JB}$	Junction-to-board thermal resistance	26.3
$R\theta_{JC}$	Junction-to-case thermal resistance	6.7
Ψ_{JT}	Junction-to-package top, Still air	0.10

Table 5-3. Thermal Resistance Characteristics (ZWT Package)

		°C / W
$R\theta_{JA}$	Junction-to-free air thermal resistance, Still air (includes 5x5 thermal via cluster in 2s2p PCB connected to 1st ground plane)	18.8
$R\theta_{JB}$	Junction-to-board thermal resistance	14.1
$R\theta_{JC}$	Junction-to-case thermal resistance	7.1
Ψ_{JT}	Junction-to-package top, Still air (includes 5x5 thermal via cluster in 2s2p PCB connected to 1st ground plane)	0.33

5.10 Output Buffer Drive Strengths

Table 5-4. Output Buffer Drive Strengths

LOW-LEVEL OUTPUT CURRENT, I_{OL} for $V_I=V_{OLmax}$ or HIGH-LEVEL OUTPUT CURRENT, I_{OH} for $V_I=V_{OHmin}$	SIGNALS
8 mA	MIBSPI5CLK, MIBSPI5SOMI[0], MIBSPI5SOMI[1], MIBSPI5SOMI[2], MIBSPI5SOMI[3], MIBSPI5SIMO[0], MIBSPI5SIMO[1], MIBSPI5SIMO[2], MIBSPI5SIMO[3], TMS, TDI, TDO, RTCK, SPI4CLK, SPI4SIMO, SPI4SOMI, nERROR, N2HET2[1], N2HET2[3], All EMIF Outputs and I/Os, All ETM Outputs
4 mA	MIBSPI3SOMI, MIBSPI3SIMO, MIBSPI3CLK, MIBSPI1SIMO, MIBSPI1SOMI, MIBSPI1CLK, nRST
2 mA zero-dominant	AD1EVT, CAN1RX, CAN1TX, CAN2RX, CAN2TX, CAN3RX, CAN3TX, DMM_CLK, DMM_DATA[0], DMM_DATA[1], DMM_nENA, DMM_SYNC, GIOA[0-7], GIOB[0-7], LINRX, LINTX, MIBSPI1NCS[0], MIBSPI1NCS[1-3], MIBSPI1NENA, MIBSPI3NCS[0-3], MIBSPI3NENA, MIBSPI5NCS[0-3], MIBSPI5NENA, N2HET1[0-31], N2HET2[0], N2HET2[2], N2HET2[4], N2HET2[5], N2HET2[6], N2HET2[7], N2HET2[8], N2HET2[9], N2HET2[10], N2HET2[11], N2HET2[12], N2HET2[13], N2HET2[14], N2HET2[15], N2HET2[16], N2HET2[18], SPI2NCS[0], SPI2NENA, SPI4NCS[0], SPI4NENA
selectable 8 mA/2 mA	ECLK, SPI2CLK, SPI2SIMO, SPI2SOMI The default output buffer drive strength is 8mA for these signals.

Table 5-5. Selectable 8 mA/2 mA Control

SIGNAL	CONTROL BIT	ADDRESS	8 mA	2 mA
ECLK	SYSPC10[0]	0xFFFF FF78	0	1
SPI2CLK	SPI2PC9[9] ⁽¹⁾	0xFFF7 F668	0	1
SPI2SIMO	SPI2PC9[10] ⁽¹⁾	0xFFF7 F668	0	1
SPI2SOMI	SPI2PC9[11] ⁽¹⁾	0xFFF7 F668	0	1

(1) Either SPI2PC9[11] or SPI2PC9[24] can change the output strength of the SPI2SOMI pin. In case of a 32-bit write where these two bits differ, SPI2PC9[11] determines the drive strength.

5.11 Input Timings



Figure 5-2. TTL-Level Inputs

Table 5-6. Timing Requirements for Inputs⁽¹⁾

		MIN	MAX	UNIT
t_{pw}	Input minimum pulse width	$t_{c(VCLK)} + 10^{(2)}$		ns

- (1) $t_{c(VCLK)}$ = peripheral VBUS clock cycle time = $1 / f_{(VCLK)}$
- (2) The timing shown in Figure 5-2 is only valid for pins used in GPIO mode.

5.12 Output Timings

Table 5-7. Switching Characteristics for Output Timings versus Load Capacitance (C_L)

PARAMETER		MIN	MAX	UNIT
Rise time, t_r	8 mA low EMI pins (see Table 5-4)	CL = 15 pF	2.5	ns
		CL = 50 pF	4	
		CL = 100 pF	7.2	
		CL = 150 pF	12.5	
Fall time, t_f	8 mA low EMI pins (see Table 5-4)	CL = 15 pF	2.5	ns
		CL = 50 pF	4	
		CL = 100 pF	7.2	
		CL = 150 pF	12.5	
Rise time, t_r	4 mA low EMI pins (see Table 5-4)	CL = 15 pF	5.6	ns
		CL = 50 pF	10.4	
		CL = 100 pF	16.8	
		CL = 150 pF	23.2	
Fall time, t_f	4 mA low EMI pins (see Table 5-4)	CL = 15 pF	5.6	ns
		CL = 50 pF	10.4	
		CL = 100 pF	16.8	
		CL = 150 pF	23.2	
Rise time, t_r	2 mA-z low EMI pins (see Table 5-4)	CL = 15 pF	8	ns
		CL = 50 pF	15	
		CL = 100 pF	23	
		CL = 150 pF	33	
Fall time, t_f	2 mA-z low EMI pins (see Table 5-4)	CL = 15 pF	8	ns
		CL = 50 pF	15	
		CL = 100 pF	23	
		CL = 150 pF	33	

Table 5-7. Switching Characteristics for Output Timings versus Load Capacitance (C_L) (continued)

PARAMETER			MIN	MAX	UNIT
Rise time, t _r	Selectable 8 mA/2 mA-z pins (see Table 5-4)	8 mA mode	CL = 15 pF	2.5	ns
			CL = 50 pF	4	
			CL = 100 pF	7.2	
			CL = 150 pF	12.5	
Fall time, t _f		8 mA mode	CL = 15 pF	2.5	ns
			CL = 50 pF	4	
			CL = 100 pF	7.2	
			CL = 150 pF	12.5	
Rise time, t _r	2 mA-z mode	CL = 15 pF	8	ns	
		CL = 50 pF	15		
		CL = 100 pF	23		
		CL = 150 pF	33		
Fall time, t _f		2 mA-z mode	CL = 15 pF	8	ns
			CL = 50 pF	15	
			CL = 100 pF	23	
			CL = 150 pF	33	

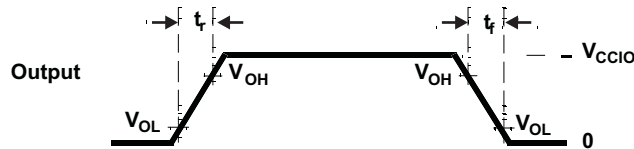

Figure 5-3. CMOS-Level Outputs

Table 5-8. Timing Requirements for Outputs⁽¹⁾

		MIN	MAX	UNIT
t _{d(parallel_out)}	Delay between low to high, or high to low transition of general-purpose output signals that can be configured by an application in parallel, for example, all signals in a GIOA port, or all N2HET1 signals, and so forth.		5	ns

(1) This specification does not account for any output buffer drive strength differences or any external capacitive loading differences. Check Table 5-4 for output buffer drive strength information on each signal.

5.13 Low-EMI Output Buffers

The low-EMI output buffer has been designed explicitly to address the issue of decoupling sources of emissions from the pins which they drive. This is accomplished by adaptively controlling the impedance of the output buffer, and is particularly effective with capacitive loads.

This is not the default mode of operation of the low-EMI output buffers and must be enabled by setting the system module GPCR1 register for the desired module or signal, as shown in . The adaptive impedance control circuit monitors the DC bias point of the output signal. The buffer internally generates two reference levels, VREFLOW and VREFHIGH, which are set to approximately 10% and 90% of VCCIO, respectively.

Once the output buffer has driven the output to a low level, if the output voltage is below VREFLOW, then the impedance of the output buffer will increase to Hi-Z. A high degree of decoupling between the internal ground bus and the output pin will occur with capacitive loads, or any load in which no current is flowing, for example, the buffer is driving low on a resistive path to ground. Current loads on the buffer which attempt to pull the output voltage above VREFLOW will be opposed by the impedance of the output buffer so as to maintain the output voltage at or below VREFLOW.

Conversely, once the output buffer has driven the output to a high level, if the output voltage is above VREFHIGH then the output buffer's impedance will again increase to Hi-Z. A high degree of decoupling between internal power bus and output pin will occur with capacitive loads or any loads in which no current is flowing, for example, buffer is driving high on a resistive path to VCCIO. Current loads on the buffer which attempt to pull the output voltage below VREFHIGH will be opposed by the buffer's output impedance so as to maintain the output voltage at or above VREFHIGH.

The bandwidth of the control circuitry is relatively low, so that the output buffer in adaptive impedance control mode cannot respond to high-frequency noise coupling into the power buses of the buffer. In this manner, internal bus noise approaching 20% peak-to-peak of VCCIO can be rejected.

Unlike standard output buffers which clamp to the rails, an output buffer in impedance control mode will allow a positive current load to pull the output voltage up to VCCIO + 0.6 V without opposition. Also, a negative current load will pull the output voltage down to VSSIO – 0.6 V without opposition. This is not an issue because the actual clamp current capability is always greater than the IOH / IOL specifications.

The low-EMI output buffers are automatically configured to be in the standard buffer mode when the device enters a low-power mode.

Table 5-9. Low-EMI Output Buffer Hookup

MODULE OR SIGNAL NAME	CONTROL REGISTER TO ENABLE LOW-EMI MODE
Module: MibSPI1	GPREG1.0
Module: SPI2	GPREG1.1
Module: MibSPI3	GPREG1.2
Reserved	GPREG1.3
Reserved	GPREG1.4
Reserved	GPREG1.5
Reserved	GPREG1.6
Reserved	GPREG1.7
Signal: TMS	GPREG1.8
Signal: TDI	GPREG1.9
Signal: TDO	GPREG1.10
Signal: RTCK	GPREG1.11
Signal: TEST	GPREG1.12
Signal: nERROR	GPREG1.13

Table 5-9. Low-EMI Output Buffer Hookup (continued)

MODULE OR SIGNAL NAME	CONTROL REGISTER TO ENABLE LOW-EMI MODE
Reserved	GPREG1.14
Reserved	GPREG1.15

6 System Information and Electrical Specifications

6.1 Device Power Domains

The device core logic is split up into multiple power domains in order to optimize the power for a given application use case. There are 8 core power domains in total: PD1, PD2, PD3, PD4, PD5, RAM_PD1, RAM_PD2 and RAM_PD3.

The actual contents of these power domains are indicated in [Section 1.4](#).

PD1 is an "always-ON" power domain, which cannot be turned off. Each of the other core power domains can be turned ON/OFF one time during device initialization as per the application requirement. Refer to the Power Management Module (PMM) chapter of RM48x Technical Reference Manual ([SPNU503](#)) for more details.

NOTE

The clocks to a module must be turned off before powering down the core domain that contains the module.

NOTE

The logic in the modules that are powered down lose power completely. Any access to modules that are powered down results in an abort being generated. When power is restored, the modules power-up to their default states (after normal power-up). No register or memory contents are preserved in the core domains that are turned off.

6.2 Voltage Monitor Characteristics

A voltage monitor is implemented on this device. The purpose of this voltage monitor is to eliminate the requirement for a specific sequence when powering up the core and I/O voltage supplies.

6.2.1 Important Considerations

- The voltage monitor does not eliminate the need of a voltage supervisor circuit to guarantee that the device is held in reset when the voltage supplies are out of range.
- The voltage monitor only monitors the core supply (VCC) and the I/O supply (VCCIO). The other supplies are not monitored by the VMON. For example, if the VCCAD or VCCP are supplied from a source different from that for VCCIO, then there is no internal voltage monitor for the VCCAD and VCCP supplies.

6.2.2 Voltage Monitor Operation

The voltage monitor generates the Power Good MCU signal (PGMCU) as well as the I/Os Power Good IO signal (PGIO) on the device. During power-up or power-down, the PGMCU and PGIO are driven low when the core or I/O supplies are lower than the specified minimum monitoring thresholds. The PGIO and PGMCU being low isolates the core logic as well as the I/O controls during the power-up or power-down of the supplies. This allows the core and I/O supplies to be powered up or down in any order.

When the voltage monitor detects a low voltage on the I/O supply, it will assert a power-on reset. When the voltage monitor detects an out-of-range voltage on the core supply, it asynchronously makes all output pins high impedance, and asserts a power-on reset. The voltage monitor is disabled when the device enters a low power mode.

The VMON also incorporates a glitch filter for the nPORRST input. Refer to [Section 6.3.3.1](#) for the timing information on this glitch filter.

Table 6-1. Voltage Monitoring Specifications

PARAMETER			MIN	TYP	MAX	UNIT
V _{MON}	Voltage monitoring thresholds	VCC low - VCC level below this threshold is detected as too low.	0.75	0.9	1.13	V
		VCC high - VCC level above this threshold is detected as too high.	1.40	1.7	2.1	
		VCCIO low - VCCIO level below this threshold is detected as too low.	1.85	2.4	2.9	

6.2.3 Supply Filtering

The VMON has the capability to filter glitches on the VCC and VCCIO supplies.

[Table 6-2](#) shows the characteristics of the supply filtering. Glitches in the supply larger than the maximum specification cannot be filtered.

Table 6-2. VMON Supply Glitch Filtering Capability

PARAMETER	MIN	MAX	UNIT
Width of glitch on VCC that can be filtered	250	1000	ns
Width of glitch on VCCIO that can be filtered	250	1000	ns

6.3 Power Sequencing and Power On Reset

6.3.1 Power-Up Sequence

There is no timing dependency between the ramp of the VCCIO and the VCC supply voltage. The power-up sequence starts with the I/O voltage rising above the minimum I/O supply threshold, (see [Table 6-4](#) for more details), core voltage rising above the minimum core supply threshold and the release of power-on reset. The high frequency oscillator will start up first and its amplitude will grow to an acceptable level. The oscillator start up time is dependent on the type of oscillator and is provided by the oscillator vendor. The different supplies to the device can be powered up in any order.

The device goes through the following sequential phases during power up.

Table 6-3. Power-Up Phases

Oscillator startup and validity check	1032 oscillator cycles
eFuse autoload	1180 oscillator cycles
Flash pump power-up	688 oscillator cycles
Flash bank power-up	617 oscillator cycles
Total	3517 oscillator cycles

The CPU reset is released at the end of the sequence in [Table 6-3](#) and fetches the first instruction from address 0x00000000.

6.3.2 Power-Down Sequence

The different supplies to the device can be powered down in any order.

6.3.3 Power-On Reset: nPORRST

This is the power-on reset. This reset must be asserted by an external circuitry whenever the I/O or core supplies are outside the specified recommended range. This signal has a glitch filter on it. It also has an internal pulldown.

6.3.3.1 nPORRST Electrical and Timing Requirements

Table 6-4. Electrical Requirements for nPORRST

NO.	PARAMETER	MIN	MAX	UNIT
	V_{CCPORL} V_{CC} low supply level when nPORRST must be active during power-up		0.5	V
	V_{CCPORH} V_{CC} high supply level when nPORRST must remain active during power-up and become active during power down	1.14		V
	$V_{CCIOPORL}$ V_{CCIO} / V_{CCP} low supply level when nPORRST must be active during power-up		1.1	V
	$V_{CCIOPORH}$ V_{CCIO} / V_{CCP} high supply level when nPORRST must remain active during power-up and become active during power down	3.0		V
	$V_{IL(PORRST)}$ Low-level input voltage of nPORRST $V_{CCIO} > 2.5V$		$0.2 * V_{CCIO}$	V
	Low-level input voltage of nPORRST $V_{CCIO} < 2.5V$		0.5	V
3	$t_{su(PORRST)}$ Setup time, nPORRST active before V_{CCIO} and $V_{CCP} > V_{CCIOPORL}$ during power-up	0		ms
6	$t_{h(PORRST)}$ Hold time, nPORRST active after $V_{CC} > V_{CCPORH}$	1		ms
7	$t_{su(PORRST)}$ Setup time, nPORRST active before $V_{CC} < V_{CCPORH}$ during power down	2		μs
8	$t_{h(PORRST)}$ Hold time, nPORRST active after V_{CCIO} and $V_{CCP} > V_{CCIOPORH}$	1		ms
9	$t_{h(PORRST)}$ Hold time, nPORRST active after $V_{CC} < V_{CCPORL}$	0		ms
	$t_f(nPORRST)$ Filter time nPORRST pin; pulses less than MIN will be filtered out, pulses greater than MAX will generate a reset.	500	2000	ns

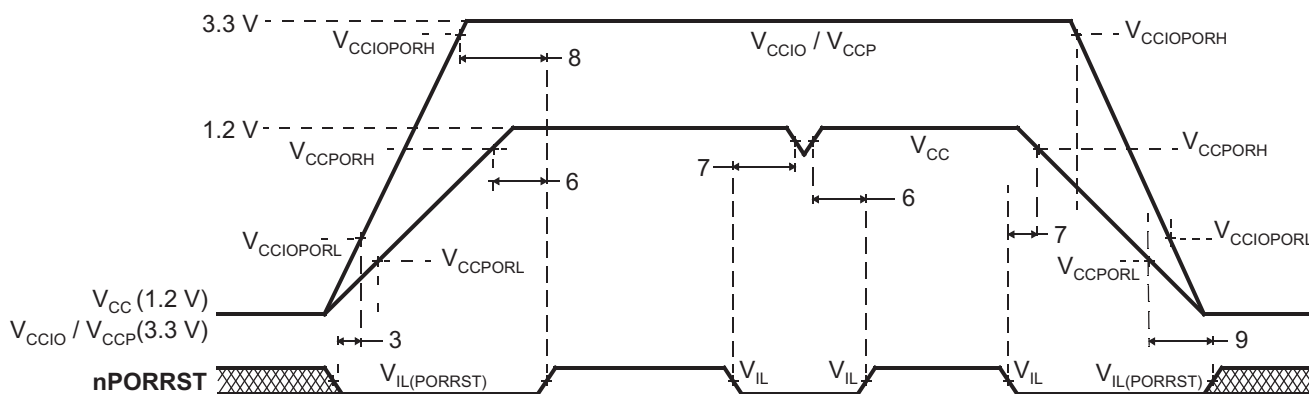

NOTE: There is no timing dependency between the ramp of the VCCIO and the VCC supply voltage; this is just an exemplary drawing.

Figure 6-1. nPORRST Timing Diagram

6.4 Warm Reset (nRST)

This is a bidirectional reset signal. The internal circuitry drives the signal low on detecting any device reset condition. An external circuit can assert a device reset by forcing the signal low. On this terminal, the output buffer is implemented as an open drain (drives low only). To ensure an external reset is not arbitrarily generated, TI recommends that an external pullup resistor is connected to this terminal.

This terminal has a glitch filter. It also has an internal pullup

6.4.1 Causes of Warm Reset

Table 6-5. Causes of Warm Reset

DEVICE EVENT	SYSTEM STATUS FLAG
Power-Up Reset	Exception Status Register, bit 15
Oscillator fail	Global Status Register, bit 0
PLL slip	Global Status Register, bits 8 and 9
Watchdog exception / Debugger reset	Exception Status Register, bit 13
CPU Reset (driven by the CPU STC)	Exception Status Register, bit 5
Software Reset	Exception Status Register, bit 4
External Reset	Exception Status Register, bit 3

6.4.2 nRST Timing Requirements

Table 6-6. nRST Timing Requirements

		MIN	MAX	UNIT
$t_{v(RST)}$	Valid time, nRST active after nPORRST inactive	$2256t_{c(OSC)}$ ⁽¹⁾		ns
	Valid time, nRST active (all other System reset conditions)	$32t_{c(VCLK)}$		
$t_{f(nRST)}$	Filter time nRST pin; pulses less than MIN will be filtered out; pulses greater than MAX will generate a reset. See Section 6.8 .	475	2000	ns

(1) Assumes the oscillator has started up and stabilized before nPORRST is released .

6.5 ARM-R4F CPU Information

6.5.1 Summary of ARM Cortex-R4F CPU Features

The features of the ARM Cortex-R4F CPU include:

- An integer unit with integral EmbeddedICE-RT logic.
- High-speed Advanced Microprocessor Bus Architecture (AMBA) Advanced eXtensible Interfaces (AXI) for Level two (L2) master and slave interfaces.
- Floating Point Coprocessor
- Dynamic branch prediction with a global history buffer, and a 4-entry return stack
- Low interrupt latency.
- Nonmaskable interrupt.
- A Harvard Level one (L1) memory system with:
 - Tightly-Coupled Memory (TCM) interfaces with support for error correction or parity checking memories
 - ARMv7-R architecture Memory Protection Unit (MPU) with 12 regions
- Dual core logic for fault detection in safety-critical applications.
- An L2 memory interface:
 - Single 64-bit master AXI interface
 - 64-bit slave AXI interface to TCM RAM blocks
- A debug interface to a CoreSight Debug Access Port (DAP).
- A trace interface to a CoreSight ETM-R4.
- A Performance Monitoring Unit (PMU).
- A Vectored Interrupt Controller (VIC) port.

For more information on the ARM Cortex-R4F CPU see www.arm.com.

6.5.2 ARM Cortex-R4F CPU Features Enabled by Software

The following CPU features are disabled on reset and must be enabled by the application if required.

- ECC On Tightly-Coupled Memory (TCM) Accesses
- Hardware Vectored Interrupt (VIC) Port
- Floating Point Coprocessor
- Memory Protection Unit (MPU)

6.5.3 Dual Core Implementation

The device has two Cortex-R4F cores, where the output signals of both CPUs are compared in the CCM-R4 unit. To avoid common mode impacts the signals of the CPUs to be compared are delayed by two clock cycles as shown in [Figure 6-3](#).

The CPUs have a diverse CPU placement given by following requirements:

- different orientation; for example, CPU1 = "north" orientation, CPU2 = "flip west" orientation
- dedicated guard ring for each CPU

North Flip West

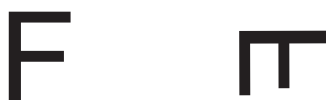

Figure 6-2. Dual-CPU Orientation

6.5.4 Duplicate Clock Tree After GCLK

The CPU clock domain is split into two clock trees, one for each CPU, with the clock of the second CPU running at the same frequency and in phase to the clock of CPU1. See [Figure 6-3](#).

6.5.5 ARM Cortex-R4F CPU Compare Module (CCM-R4) for Safety

This device has two ARM Cortex-R4F CPU cores, where the output signals of both CPUs are compared in the CCM-R4 unit. To avoid common mode impacts the signals of the CPUs to be compared are delayed in a different way as shown in [Figure 6-3](#).

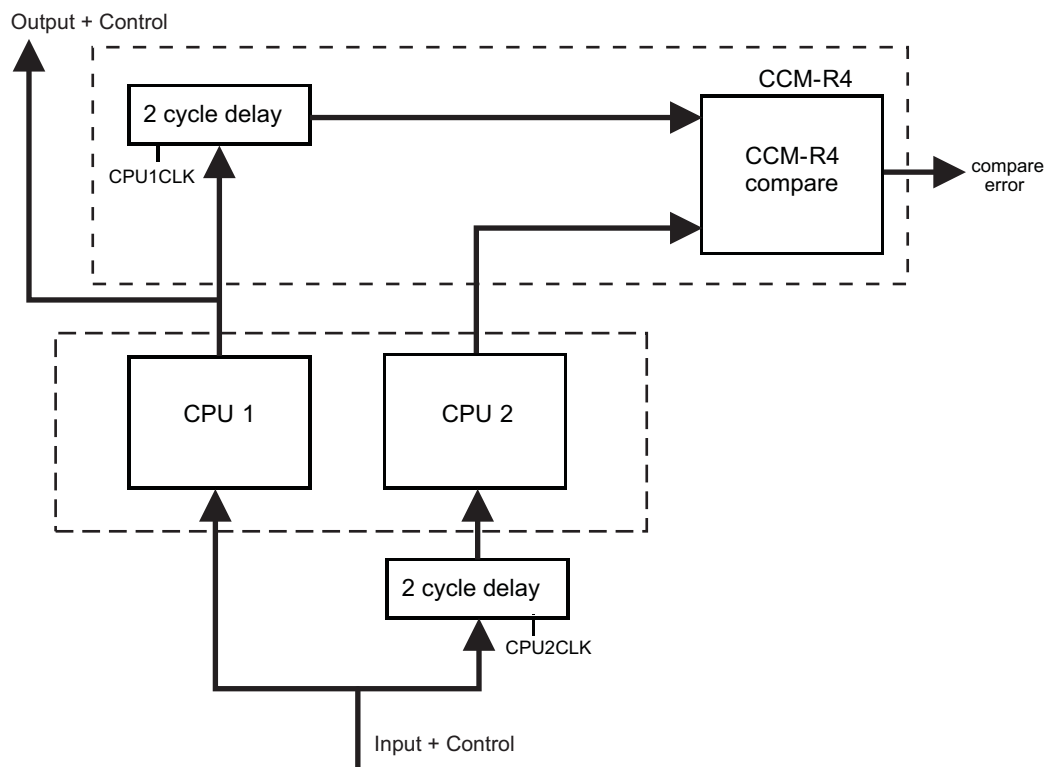

Figure 6-3. Dual Core Implementation

To avoid an erroneous CCM-R4 compare error, the application software must initialize the registers of both CPUs before the registers are used, including function calls where the register values are pushed onto the stack.

6.5.6 CPU Self-Test

The CPU STC (Self-Test Controller) is used to test the two Cortex-R4F CPU Cores using the Deterministic Logic BIST Controller as the test engine.

The main features of the self-test controller are:

- Ability to divide the complete test run into independent test intervals
- Capable of running the complete test as well as running few intervals at a time
- Ability to continue from the last executed interval (test set) as well as ability to restart from the beginning (First test set)
- Complete isolation of the self-tested CPU core from rest of the system during the self-test run
- Ability to capture the Failure interval number
- Time-out counter for the CPU self-test run as a fail-safe feature

6.5.6.1 Application Sequence for CPU Self-Test

1. Configure clock domain frequencies.
2. Select number of test intervals to be run.
3. Configure the time-out period for the self-test run.
4. Enable self-test.
5. Wait for CPU reset.
6. In the reset handler, read CPU self-test status to identify any failures.
7. Retrieve CPU state if required.

For more information see the device specific technical reference manual.

6.5.6.2 CPU Self-Test Clock Configuration

The maximum clock rate for the self-test is 110MHz. The STCCLK is divided down from the CPU clock. This divider is configured by the STCCLKDIV register at address 0xFFFFE108.

For more information see the device specific technical reference manual.

6.5.6.3 CPU Self-Test Coverage

Table 6-7 shows CPU test coverage achieved for each self-test interval. It also lists the cumulative test cycles. The test time can be calculated by multiplying the number of test cycles with the STC clock period.

Table 6-7. CPU Self-Test Coverage

INTERVALS	TEST COVERAGE, %	TEST CYCLES
0	0	0
1	62.13	1365
2	70.09	2730
3	74.49	4095
4	77.28	5460
5	79.28	6825
6	80.90	8190
7	82.02	9555
8	83.10	10920
9	84.08	12285
10	84.87	13650
11	85.59	15015
12	86.11	16380
13	86.67	17745
14	87.16	19110
15	87.61	20475
16	87.98	21840
17	88.38	23205
18	88.69	24570
19	88.98	25935
20	89.28	27300
21	89.50	28665
22	89.76	30030
23	90.01	31395
24	90.21	32760

6.6 Clocks

6.6.1 Clock Sources

Table 6-8 lists the available clock sources on the device. Each of the clock sources can be enabled or disabled using the CSDISx registers in the system module. The clock source number in the table corresponds to the control bit in the CSDISx register for that clock source.

Table 6-8 also shows the default state of each clock source.

Table 6-8. Available Clock Sources

CLOCK SOURCE #	NAME	DESCRIPTION	DEFAULT STATE
0	OSCIN	Main Oscillator	Enabled
1	PLL1	Output From PLL1	Disabled
2	Reserved	Reserved	Disabled
3	EXTCLKIN1	External Clock Input #1	Disabled
4	CLK80K	Low Frequency Output of Internal Reference Oscillator	Enabled
5	CLK10M	High Frequency Output of Internal Reference Oscillator	Enabled
6	PLL2	Output From PLL2	Disabled
7	EXTCLKIN2	External Clock Input #2	Disabled

6.6.1.1 Main Oscillator

The oscillator is enabled by connecting the appropriate fundamental resonator/crystal and load capacitors across the external OSCIN and OSCOUT pins as shown in Figure 6-4. The oscillator is a single stage inverter held in bias by an integrated bias resistor. This resistor is disabled during leakage test measurement and low power modes.

TI strongly encourages each customer to submit samples of the device to the resonator/crystal vendors for validation. The vendors are equipped to determine what load capacitors will best tune their resonator/crystal to the microcontroller device for optimum startup and operation over temperature/voltage extremes.

An external oscillator source can be used by connecting a 3.3-V clock signal to the OSCIN pin and leaving the OSCOUT pin unconnected (open) as shown in Figure 6-4.



Note A: The values of C1 and C2 should be provided by the resonator/crystal vendor.

Note B: Kelvin_GND should not be connected to any other GND.

Figure 6-4. Recommended Crystal/Clock Connection

6.6.1.1.1 Timing Requirements for Main Oscillator

Table 6-9. Timing Requirements for Main Oscillator

		MIN	MAX	UNIT
$t_{c(OSC)}$	Cycle time, OSCIN (when using a sine-wave input)	50	200	ns
$t_{c(OSC_SQR)}$	Cycle time, OSCIN, (when input to the OSCIN is a square wave)	50	200	ns
$t_{w(OSCIL)}$	Pulse duration, OSCIN low (when input to the OSCIN is a square wave)	6		ns
$t_{w(OSCIH)}$	Pulse duration, OSCIN high (when input to the OSCIN is a square wave)	6		ns

6.6.1.2 Low Power Oscillator

The Low Power Oscillator (LPO) is comprised of two oscillators — HF LPO and LF LPO, in a single macro.

6.6.1.2.1 Features

The main features of the LPO are:

- Supplies a clock at extremely low power for power-saving modes. This is connected as clock source # 4 of the Global Clock Module.
- Supplies a high-frequency clock for nontiming-critical systems. This is connected as clock source # 5 of the Global Clock Module.
- Provides a comparison clock for the crystal oscillator failure detection circuit.

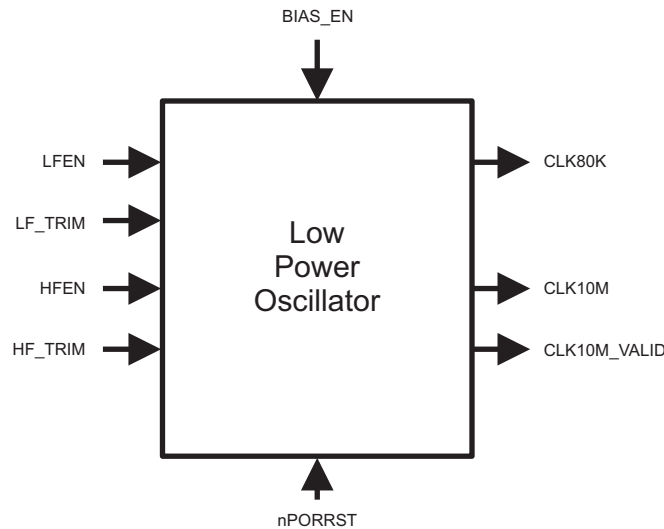

Figure 6-5. LPO Block Diagram

Figure 6-5 shows a block diagram of the internal reference oscillator. This is a low power oscillator (LPO) and provides two clock sources: one nominally 80 kHz and one nominally 10 MHz.

6.6.1.2.2 LPO Electrical and Timing Specifications

Table 6-10. LPO Specifications

PARAMETER		MIN	TYP	MAX	UNIT
Clock Detection	Oscillator fail frequency - lower threshold, using untrimmed LPO output	1.375	2.4	4.875	MHz
	Oscillator fail frequency - higher threshold, using untrimmed LPO output	22	38.4	78	MHz
LPO - HF oscillator (f _{HFLPO})	Untrimmed frequency	5.5	9	19.5	MHz
	Trimmed frequency	8	9.6	11	MHz
	Startup time from STANDBY (LPO BIAS_EN High for at least 900µs)			10	µs
	Cold startup time			900	µs
LPO - LF oscillator (f _{LFLPO})	Untrimmed frequency	36	85	180	kHz
	Startup time from STANDBY (LPO BIAS_EN High for at least 900µs)			100	µs
	cold startup time			2000	µs

6.6.1.3 Phase Locked Loop (PLL) Clock Modules

The PLL is used to multiply the input frequency to some higher frequency.

The main features of the PLL are:

- Frequency modulation can be optionally superimposed on the synthesized frequency of PLL1. The frequency modulation capability of PLL2 is permanently disabled.
- Configurable frequency multipliers and dividers.
- Built-in PLL Slip monitoring circuit.
- Option to reset the device on a PLL slip detection.

6.6.1.3.1 Block Diagram

Figure 6-6 shows a high-level block diagram of the two PLL macros on this microcontroller. PLLCTL1 and PLLCTL2 are used to configure the multiplier and dividers for the PLL1. PLLCTL3 is used to configure the multiplier and dividers for PLL2.

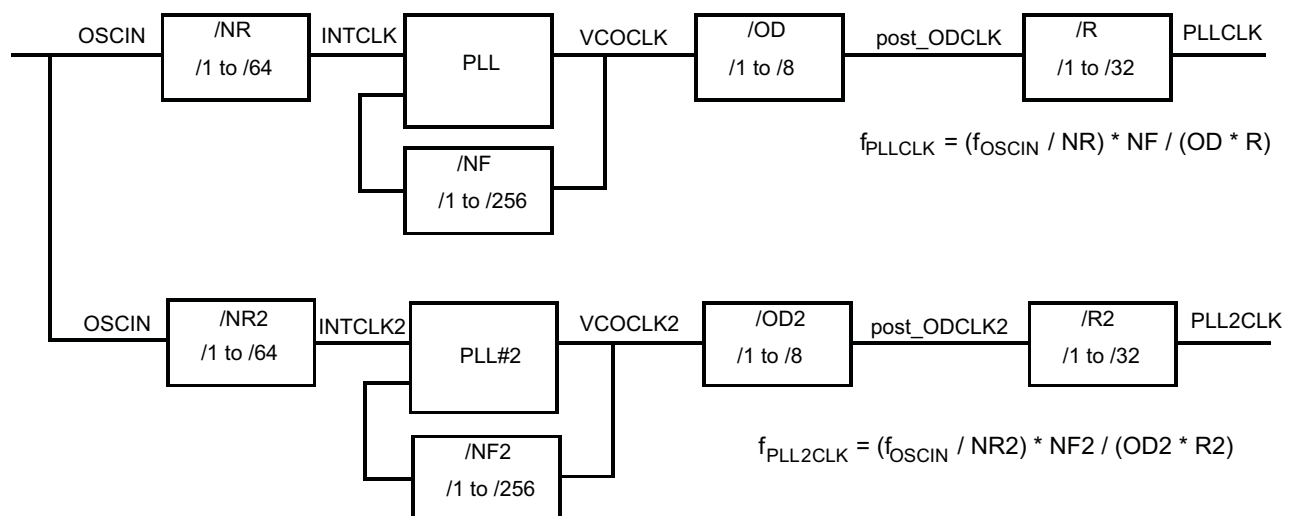

Figure 6-6. ZWT PLLx Block Diagram

6.6.1.3.2 PLL Timing Specifications

Table 6-11. PLL Timing Specifications

PARAMETER		MIN	MAX	UNIT
f _{INTCLK}	PLL1 Reference Clock frequency	1	20	MHz
f _{post_ODCLK}	Post-ODCLK – PLL1 Post-divider input clock frequency		400	MHz
f _{VCOCLK}	VCOCLK – PLL1 Output Divider (OD) input clock frequency	150	550	MHz
f _{INTCLK2}	PLL2 Reference Clock frequency	1	20	MHz
f _{post_ODCLK2}	Post-ODCLK – PLL2 Post-divider input clock frequency		400	MHz
f _{VCOCLK2}	VCOCLK – PLL2 Output Divider (OD) input clock frequency	150	550	MHz

6.6.1.4 External Clock Inputs

The device supports up to two external clock inputs. This clock input must be a square wave input. The electrical and timing requirements for these clock inputs are specified in [Table 6-12](#). The external clock sources are not checked for validity. They are assumed valid when enabled.

Table 6-12. External Clock Timing and Electrical Specifications

PARAMETER	DESCRIPTION	MIN	MAX	UNIT
$f_{EXTCLKx}$	External clock input frequency		80	MHz
$t_{w(EXTCLKIN)H}$	EXTCLK high-pulse duration	6		ns
$t_{w(EXTCLKIN)L}$	EXTCLK low-pulse duration	6		ns
$V_{IL(EXTCLKIN)}$	Low-level input voltage	-0.3	0.8	V
$V_{IH(EXTCLKIN)}$	High-level input voltage	2	VCCIO + 0.3	V

6.6.2 Clock Domains

6.6.2.1 Clock Domain Descriptions

[Table 6-13](#) lists the device clock domains and their default clock sources. The table also shows the system module control register that is used to select an available clock source for each clock domain.

Table 6-13. Clock Domain Descriptions

CLOCK DOMAIN NAME	DEFAULT CLOCK SOURCE	CLOCK SOURCE SELECTION REGISTER	DESCRIPTION
HCLK	OSCIN	GHVSRC	<ul style="list-style-type: none"> Is disabled via the CDDISx registers bit 1 Used for all system modules including DMA, ESM
GCLK	OSCIN	GHVSRC	<ul style="list-style-type: none"> Always the same frequency as HCLK In phase with HCLK Is disabled separately from HCLK via the CDDISx registers bit 0 Can be divided by 1 up to 8 when running CPU self-test (LBIST) using the CLKDIV field of the STCCLKDIV register at address 0xFFFFE108
GCLK2	OSCIN	GHVSRC	<ul style="list-style-type: none"> Always the same frequency as GCLK 2 cycles delayed from GCLK Is disabled along with GCLK Gets divided by the same divider setting as that for GCLK when running CPU self-test (LBIST)
VCLK	OSCIN	GHVSRC	<ul style="list-style-type: none"> Divided down from HCLK Can be HCLK/1, HCLK/2, ... or HCLK/16 Is disabled separately from HCLK via the CDDISx registers bit 2
VCLK2	OSCIN	GHVSRC	<ul style="list-style-type: none"> Divided down from HCLK Can be HCLK/1, HCLK/2, ... or HCLK/16 Frequency must be an integer multiple of VCLK frequency Is disabled separately from HCLK via the CDDISx registers bit 3
VCLK3	OSCIN	GHVSRC	<ul style="list-style-type: none"> Divided down from HCLK Can be HCLK/1, HCLK/2, ... or HCLK/16 Is disabled separately from HCLK via the CDDISx registers bit 8
VCLKA1	VCLK	VCLKASRC	<ul style="list-style-type: none"> Defaults to VCLK as the source Is disabled via the CDDISx registers bit 4
VCLKA3	VCLK	VCLKACON1	<ul style="list-style-type: none"> Defaults to VCLK as the source Frequency can be as fast as HCLK frequency. Is disabled via the CDDISx registers bit 10

Table 6-13. Clock Domain Descriptions (continued)

CLOCK DOMAIN NAME	DEFAULT CLOCK SOURCE	CLOCK SOURCE SELECTION REGISTER	DESCRIPTION
VCLKA3_DIVR	VCLK	VCLKACON1	<ul style="list-style-type: none"> Divided down from the VCLKA3 using the VCLKA3R field of the VCLKACON1 register at address 0xFFFFE140 Frequency can be VCLKA3/1, VCLKA3/2, ..., or VCLKA3/8 Default frequency is VCLKA3/2 Is disabled separately via the VCLKACON1 register VCLKA3_DIV_CDDIS bit only if the VCLKA3 clock is not disabled
VCLKA4	VCLK	VCLKACON1	<ul style="list-style-type: none"> Defaults to VCLK as the source Is disabled via the CDDISx registers bit 11
RTICK	VCLK	RCLKSRC	<ul style="list-style-type: none"> Defaults to VCLK as the source If a clock source other than VCLK is selected for RTICK, then the RTICK frequency must be less than or equal to VCLK/3 <ul style="list-style-type: none"> Application can ensure this by programming the RTI1DIV field of the RCLKSRC register, if necessary Is disabled via the CDDISx registers bit 6

6.6.2.2 Mapping of Clock Domains to Device Modules

Each clock domain has a dedicated functionality as shown in Figure 6-7.

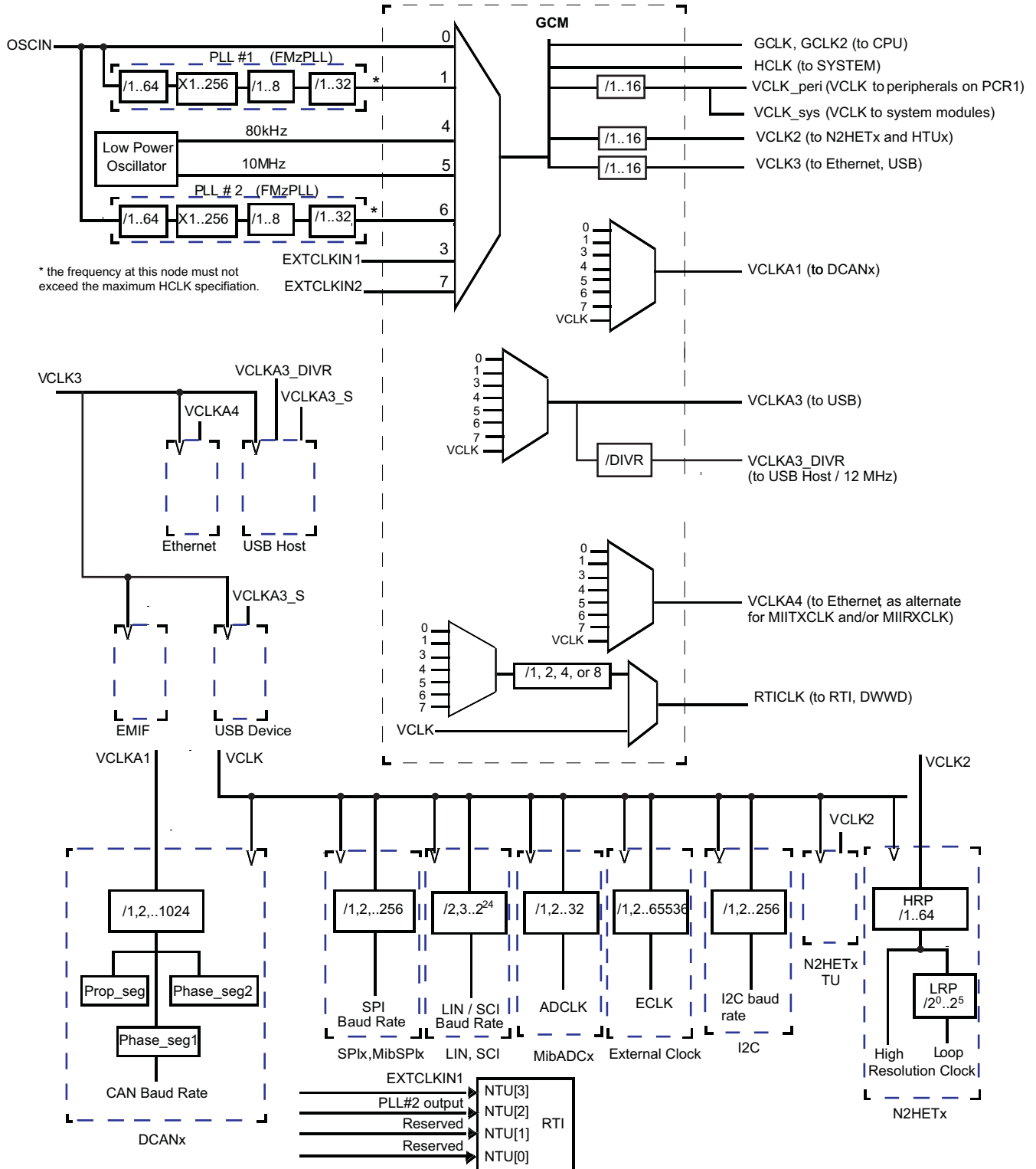

Figure 6-7. Device Clock Domains

6.6.3 Clock Test Mode

The RM4x platform architecture defines a special mode that allows various clock signals to be brought out on to the ECLK pin and N2HET1[12] device outputs. This mode is called the Clock Test mode. It is very useful for debugging purposes and can be configured via the CLKTEST register in the system module.

Table 6-14. Clock Test Mode Options

SEL_ECP_PIN = CLKTEST[3-0]	SIGNAL ON ECLK	SEL_GIO_PIN = CLKTEST[11-8]	SIGNAL ON N2HET1[12]
0000	Oscillator	0000	Oscillator Valid Status
0001	Main PLL free-running clock output	0001	Main PLL Valid status
0010	Reserved	0010	Reserved
0011	EXTCLKIN1	0011	Reserved
0100	CLK80K	0100	Reserved
0101	CLK10M	0101	CLK10M Valid status
0110	Secondary PLL free-running clock output	0110	Secondary PLL Valid Status
0111	EXTCLKIN2	0111	Reserved
1000	GCLK	1000	CLK80K
1001	RTI Base	1001	Reserved
1010	Reserved	1010	Reserved
1011	VCLKA1	1011	Reserved
1100	Reserved	1100	Reserved
1101	VCLKA3	1101	Reserved
1110	VCLKA4	1110	Reserved
1111	Reserved	1111	Reserved

6.7 Clock Monitoring

The LPO Clock Detect (LPOCLKDET) module consists of a clock monitor (CLKDET) and an internal low power oscillator (LPO).

The LPO provides two different clock sources – a low frequency (LFLPO) and a high frequency (HFLPO).

The CLKDET is a supervisor circuit for an externally supplied clock signal (OSCIN). In case the OSCIN frequency falls out of a frequency window, the CLKDET flags this condition in the global status register (GLBSTAT bit 0: OSC FAIL) and switches all clock domains sourced by OSCIN to the HFLPO clock (limp mode clock).

The valid OSCIN frequency range is defined as: $f_{\text{HFLPO}} / 4 < f_{\text{OSCIN}} < f_{\text{HFLPO}} * 4$.

6.7.1 Clock Monitor Timings

For more information on LPO and Clock detection, refer to [Table 6-10](#).

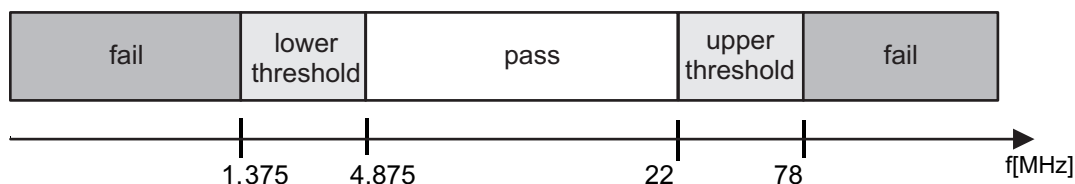

Figure 6-8. LPO and Clock Detection, Untrimmed HFLPO

6.7.2 External Clock (ECLK) Output Functionality

The ECLK pin can be configured to output a prescaled clock signal indicative of an internal device clock. This output can be externally monitored as a safety diagnostic.

6.7.3 Dual Clock Comparators

The Dual Clock Comparator (DCC) module determines the accuracy of selectable clock sources by counting the pulses of two independent clock sources (counter 0 and counter 1). If one clock is out of spec, an error signal is generated. For example, the DCC1 can be configured to use CLK10M as the reference clock (for counter 0) and VCLK as the "clock under test" (for counter 1). This configuration allows the DCC1 to monitor the PLL output clock when VCLK is using the PLL output as its source.

An additional use of this module is to measure the frequency of a selectable clock source, using the input clock as a reference, by counting the pulses of two independent clock sources. Counter 0 generates a fixed-width counting window after a preprogrammed number of pulses. Counter 1 generates a fixed-width pulse (1 cycle) after a preprogrammed number of pulses. This pulse sets as an error signal if counter 1 does not reach 0 within the counting window generated by counter 0.

6.7.3.1 Features

- Takes two different clock sources as input to two independent counter blocks.
- One of the clock sources is the known-good, or reference clock; the second clock source is the "clock under test."
- Each counter block is programmable with initial, or seed values.
- The counter blocks start counting down from their seed values at the same time; a mismatch from the expected frequency for the clock under test generates an error signal which is used to interrupt the CPU.

6.7.3.2 Mapping of DCC Clock Source Inputs

Table 6-15. DCC1 Counter 0 Clock Sources

CLOCK SOURCE [3:0]	CLOCK NAME
others	oscillator (OSCIN)
0x5	high frequency LPO
0xA	test clock (TCK)

Table 6-16. DCC1 Counter 1 Clock Sources

KEY [3:0]	CLOCK SOURCE [3:0]	CLOCK NAME
others	-	N2HET1[31]
0xA	0x0	Main PLL free-running clock output
	0x1	reserved
	0x2	low frequency LPO
	0x3	high frequency LPO
	0x4	flash HD pump oscillator
	0x5	EXTCLKIN1
	0x6	EXTCLKIN2
	0x7	ring oscillator
	0x8 - 0xF	VCLK

Table 6-17. DCC2 Counter 0 Clock Sources

CLOCK SOURCE [3:0]	CLOCK NAME
others	oscillator (OSCIN)
0xA	test clock (TCK)

Table 6-18. DCC2 Counter 1 Clock Sources

KEY [3:0]	CLOCK SOURCE [3:0]	CLOCK NAME
others	-	N2HET2[0]
0xA	00x0 - 0x7	Reserved
	0x8 - 0xF	VCLK

6.8 Glitch Filters

A glitch filter is present on the following signals.

Table 6-19. Glitch Filter Timing Specifications

PIN	PARAMETER	MIN	MAX	UNIT
nPORRST	$t_{f(nPORRST)}$ Filter time nPORRST pin; pulses less than MIN will be filtered out, pulses greater than MAX will generate a reset ⁽¹⁾	475	2000	ns
nRST	$t_{f(nRST)}$ Filter time nRST pin; pulses less than MIN will be filtered out, pulses greater than MAX will generate a reset	475	2000	ns
TEST	$t_{f(TEST)}$ Filter time TEST pin; pulses less than MIN will be filtered out, pulses greater than MAX will pass through	475	2000	ns

- (1) The glitch filter design on the nPORRST signal is designed such that no size pulse will reset any part of the microcontroller (flash pump, I/O pins, and so forth) without also generating a valid reset signal to the CPU.

6.9 Device Memory Map

6.9.1 Memory Map Diagram

Figure 6-9 shows the device memory map.

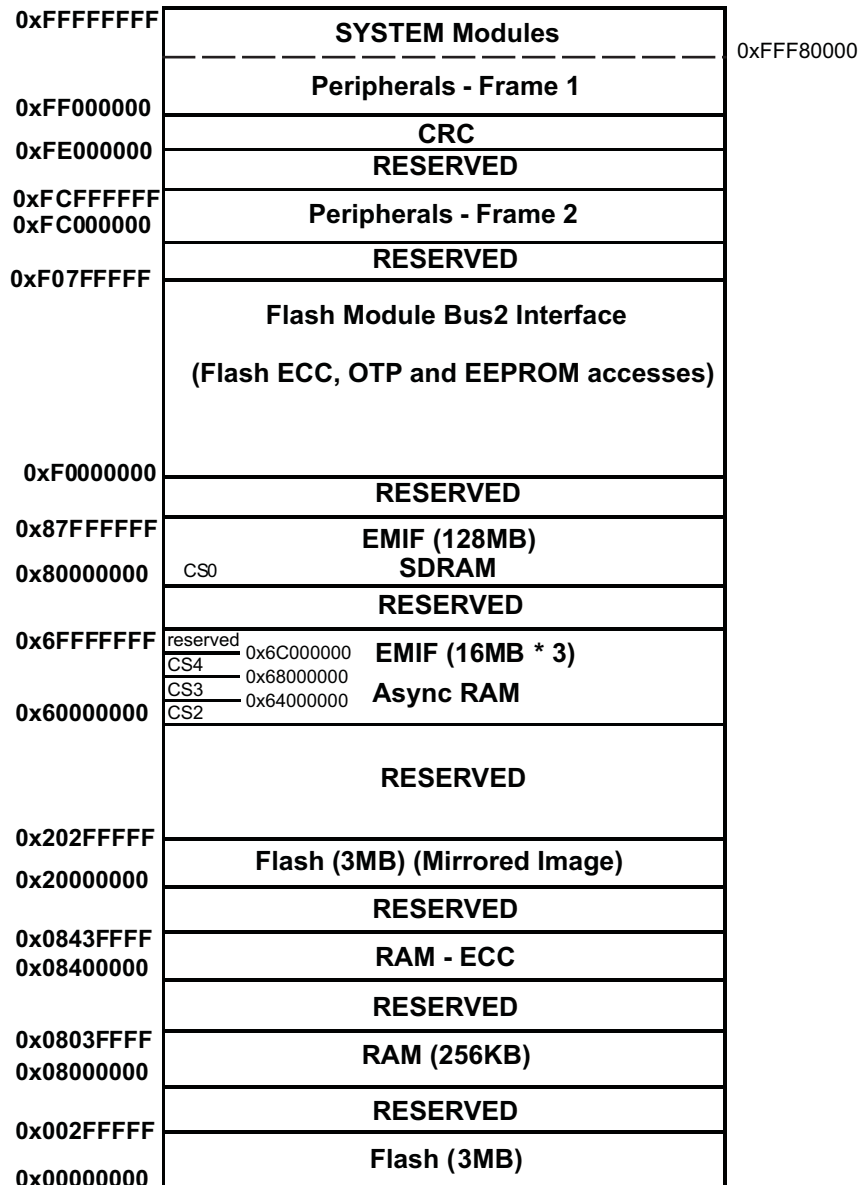

Figure 6-9. RM48L952 Memory Map

The Flash memory is mirrored to support ECC logic testing. The base address of the mirrored Flash image is 0x2000 0000.

6.9.2 Memory Map Table

Table 6-20. Device Memory Map

MODULE NAME	FRAME CHIP SELECT	FRAME ADDRESS RANGE		FRAME SIZE	ACTUAL SIZE	RESPONSE FOR ACCESS TO UNIMPLEMENTED LOCATIONS IN FRAME
		START	END			
MEMORIES TIGHTLY COUPLED TO THE ARM CORTEX-R4F CPU						
TCM Flash	CS0	0x00000000	0x00FFFFFF	16MB	3MB	Abort
TCM RAM + RAM ECC	CSRAM0	0x08000000	0x0BFFFFFF	64MB	256KB	
Mirrored Flash	Flash mirror frame	0x20000000	0x20FFFFFF	16MB	3MB	
EXTERNAL MEMORY ACCESSES						
EMIF Chip Select 2 (asynchronous)	EMIF select 2	0x60000000	0x63FFFFFF	64MB	16MB	Access to "Reserved" space will generate Abort
EMIF Chip Select 3 (asynchronous)	EMIF select 3	0x64000000	0x67FFFFFF	64MB	16MB	
EMIF Chip Select 4 (asynchronous)	EMIF select 4	0x68000000	0x6BFFFFFF	64MB	16MB	
EMIF Chip Select 0 (synchronous)	EMIF select 0	0x80000000	0x87FFFFFF	128MB	128MB	
FLASH MODULE BUS2 INTERFACE						
Customer OTP, TCM Flash Bank 0		0xF0000000	0xF0001FFF	8KB	4KB	Abort
Customer OTP, TCM Flash Bank 1		0xF0002000	0xF0003FFF	8KB	4KB	
Customer OTP, EEPROM Bank 7		0xF000E000	0xF000FFFF	8KB	2KB	
Customer OTP–ECC, TCM Flash Bank 0		0xF0040000	0xF00403FF	1KB	512B	
Customer OTP–ECC, TCM Flash Bank 1		0xF0040400	0xF00407FF	1KB	512B	
Customer OTP–ECC, EEPROM Bank 7		0xF0041C00	0xF0041FFF	1KB	256B	
TI OTP, TCM Flash Bank 0		0xF0080000	0xF0081FFF	8KB	4KB	
TI OTP, TCM Flash Bank 1		0xF0082000	0xF0083FFF	8KB	4KB	
TI OTP, EEPROM Bank 7		0xF008E000	0xF008FFFF	8KB	2KB	
TI OTP–ECC, TCM Flash Bank 0		0xF00C0000	0xF00C03FF	1KB	512B	
TI OTP–ECC, TCM Flash Bank 1		0xF00C0400	0xF00C07FF	1KB	512B	
TI OTP–ECC, EEPROM Bank 7		0xF00C1C00	0xF00C1FFF	1KB	256B	
EEPROM Bank–ECC		0xF0100000	0xF013FFFF	256KB	8KB	
EEPROM Bank		0xF0200000	0xF03FFFFFFF	2MB	64KB	
Flash Data Space ECC		0xF0400000	0xF04FFFFFFF	1MB	384KB	
ETHERNET AND EMIF SLAVE INTERFACES						
CPPI Memory Slave (Ethernet RAM)		0xFC520000	0xFC521FFF	8KB	8KB	Abort
EMAC Slave (Ethernet Slave)		0xFCF78000	0xFCF787FF	2KB	2KB	No error
EMACSS Wrapper (Ethernet Wrapper)		0xFCF78800	0xFCF788FF	256B	256B	No error
Ethernet MDIO Interface		0xFCF78900	0xFCF789FF	256B	256B	No error

Table 6-20. Device Memory Map (continued)

MODULE NAME	FRAME CHIP SELECT	FRAME ADDRESS RANGE		FRAME SIZE	ACTUAL SIZE	RESPONSE FOR ACCESS TO UNIMPLEMENTED LOCATIONS IN FRAME
		START	END			
W2FC (USB device controller registers)		0xFCF78A00	0xFCF78A7F	128B	128B	Abort
OHCI (USB Host controller registers)		0xFCF78B00	0xFCF78BFF	256B	256B	Abort
EMIF Registers		0xFCFFE800	0xFCFFE8FF	256B	256B	Abort
CYCLIC REDUNDANCY CHECKER (CRC) MODULE REGISTERS						
CRC	CRC frame	0xFE000000	0xFEFFFFFF	16MB	512B	Accesses above 0x200 generate abort.
PERIPHERAL MEMORIES						
MIBSPI5 RAM	PCS[5]	0xFF0A0000	0xFF0BFFFF	128KB	2KB	Abort for accesses above 2KB
MIBSPI3 RAM	PCS[6]	0xFF0C0000	0xFF0DFFFF	128KB	2KB	Abort for accesses above 2KB
MIBSPI1 RAM	PCS[7]	0xFF0E0000	0xFF0FFFFFF	128KB	2KB	Abort for accesses above 2KB
DCAN3 RAM	PCS[13]	0xFF1A0000	0xFF1BFFFF	128KB	2KB	Wrap around for accesses to unimplemented address offsets lower than 0x7FF. Abort generated for accesses beyond offset 0x800.
DCAN2 RAM	PCS[14]	0xFF1C0000	0xFF1DFFFF	128KB	2KB	Wrap around for accesses to unimplemented address offsets lower than 0x7FF. Abort generated for accesses beyond offset 0x800.
DCAN1 RAM	PCS[15]	0xFF1E0000	0xFF1FFFFFF	128KB	2KB	Wrap around for accesses to unimplemented address offsets lower than 0x7FF. Abort generated for accesses beyond offset 0x800.
MIBADC2 RAM	PCS[29]	0xFF3A0000	0xFF3BFFFF	128KB	8KB	Wrap around for accesses to unimplemented address offsets lower than 0x1FFF. Abort generated for accesses beyond 0x1FFF.
MIBADC1 RAM	PCS[31]	0xFF3E0000	0xFF3FFFFFF	128KB	8KB	Wrap around for accesses to unimplemented address offsets lower than 0x1FFF. Abort generated for accesses beyond 0x1FFF.
N2HET2 RAM	PCS[34]	0xFF440000	0xFF45FFFF	128KB	16KB	Wrap around for accesses to unimplemented address offsets lower than 0x3FFF. Abort generated for accesses beyond 0x3FFF.
N2HET1 RAM	PCS[35]	0xFF460000	0xFF47FFFF	128KB	16KB	Wrap around for accesses to unimplemented address offsets lower than 0x3FFF. Abort generated for accesses beyond 0x3FFF.
HTU2 RAM	PCS[38]	0xFF4C0000	0xFF4DFFFF	128KB	1KB	Abort
HTU1 RAM	PCS[39]	0xFF4E0000	0xFF4FFFFFF	128KB	1KB	Abort
DEBUG COMPONENTS						
CoreSight Debug ROM	CSCS0	0xFFA00000	0xFFA00FFF	4KB	4KB	Reads: 0, writes: no effect
Cortex-R4F Debug	CSCS1	0xFFA01000	0xFFA01FFF	4KB	4KB	Reads: 0, writes: no effect
ETM-R4	CSCS2	0xFFA02000	0xFFA02FFF	4KB	4KB	Reads: 0, writes: no effect
CoreSight TPIU	CSCS3	0xFFA03000	0xFFA03FFF	4KB	4KB	Reads: 0, writes: no effect
POM	CSCS4	0xFFA04000	0xFFA04FFF	4KB	4KB	Abort
PERIPHERAL CONTROL REGISTERS						
HTU1	PS[22]	0xFFF7A400	0xFFF7A4FF	256B	256B	Reads: 0, writes: no effect
HTU2	PS[22]	0xFFF7A500	0xFFF7A5FF	256B	256B	Reads: 0, writes: no effect
N2HET1	PS[17]	0xFFF7B800	0xFFF7B8FF	256B	256B	Reads: 0, writes: no effect
N2HET2	PS[17]	0xFFF7B900	0xFFF7B9FF	256B	256B	Reads: 0, writes: no effect
GPIO	PS[16]	0xFFF7BC00	0xFFF7BCFF	256B	256B	Reads: 0, writes: no effect
MIBADC1	PS[15]	0xFFF7C000	0xFFF7C1FF	512B	512B	Reads: 0, writes: no effect
MIBADC2	PS[15]	0xFFF7C200	0xFFF7C3FF	512B	512B	Reads: 0, writes: no effect
I2C	PS[10]	0xFFF7D400	0xFFF7D4FF	256B	256B	Reads: 0, writes: no effect
DCAN1	PS[8]	0xFFF7DC00	0xFFF7DDFF	512B	512B	Reads: 0, writes: no effect

Table 6-20. Device Memory Map (continued)

MODULE NAME	FRAME CHIP SELECT	FRAME ADDRESS RANGE		FRAME SIZE	ACTUAL SIZE	RESPONSE FOR ACCESS TO UNIMPLEMENTED LOCATIONS IN FRAME
		START	END			
DCAN2	PS[8]	0xFFF7DE00	0xFFF7DFFF	512B	512B	Reads: 0, writes: no effect
DCAN3	PS[7]	0xFFF7E000	0xFFF7E1FF	512B	512B	Reads: 0, writes: no effect
LIN	PS[6]	0xFFF7E400	0xFFF7E4FF	256B	256B	Reads: 0, writes: no effect
SCI	PS[6]	0xFFF7E500	0xFFF7E5FF	256B	256B	Reads: 0, writes: no effect
MibSPI1	PS[2]	0xFFF7F400	0xFFF7F5FF	512B	512B	Reads: 0, writes: no effect
MibSPI3	PS[1]	0xFFF7F800	0xFFF7F9FF	512B	512B	Reads: 0, writes: no effect
SPI4	PS[1]	0xFFF7FA00	0xFFF7FBFF	512B	512B	Reads: 0, writes: no effect
MibSPI5	PS[0]	0xFFF7FC00	0xFFF7DFFF	512B	512B	Reads: 0, writes: no effect
SYSTEM MODULES CONTROL REGISTERS AND MEMORIES						
DMA RAM	PPCS0	0xFFF80000	0xFFF80FFF	4KB	4KB	Abort
VIM RAM	PPCS2	0xFFF82000	0xFFF82FFF	4KB	1KB	Wrap around for accesses to unimplemented address offsets between 1kB and 4kB.
RTP RAM	PPCS3	0xFFF83000	0xFFF83FFF	4KB	4KB	Abort
Flash Module	PPCS7	0xFFF87000	0xFFF87FFF	4KB	4KB	Abort
eFuse Controller	PPCS12	0xFFF8C000	0xFFF8CFFF	4KB	4KB	Abort
Power Management Module (PMM)	PPSE0	0xFFFF0000	0xFFFF01FF	512B	512B	Abort
Test Controller (FMTM)	PPSE1	0xFFFF0400	0xFFFF07FF	1KB	1KB	Reads: 0, writes: no effect
PCR registers	PPS0	0xFFFFE000	0xFFFFE0FF	256B	256B	Reads: 0, writes: no effect
System Module - Frame 2 (see device TRM)	PPS0	0xFFFFE100	0xFFFFE1FF	256B	256B	Reads: 0, writes: no effect
PBIST	PPS1	0xFFFFE400	0xFFFFE5FF	512B	512B	Reads: 0, writes: no effect
STC	PPS1	0xFFFFE600	0xFFFFE6FF	256B	256B	Generates address error interrupt, if enabled
IOMM Multiplexing Control Module	PPS2	0xFFFFEA00	0xFFFFEBFF	512B	512B	Reads: 0, writes: no effect
DCC1	PPS3	0xFFFFEC00	0xFFFFECFF	256B	256B	Reads: 0, writes: no effect
DMA	PPS4	0xFFFFF000	0xFFFFF3FF	1KB	1KB	Reads: 0, writes: no effect
DCC2	PPS5	0xFFFFF400	0xFFFFF4FF	256B	256B	Reads: 0, writes: no effect
ESM	PPS5	0xFFFFF500	0xFFFFF5FF	256B	256B	Reads: 0, writes: no effect
CCMR4	PPS5	0xFFFFF600	0xFFFFF6FF	256B	256B	Reads: 0, writes: no effect
DMM	PPS5	0xFFFFF700	0xFFFFF7FF	256B	256B	Reads: 0, writes: no effect
RAM ECC even	PPS6	0xFFFFF800	0xFFFFF8FF	256B	256B	Reads: 0, writes: no effect
RAM ECC odd	PPS6	0xFFFFF900	0xFFFFF9FF	256B	256B	Reads: 0, writes: no effect
RTP	PPS6	0xFFFFFA00	0xFFFFFAFF	256B	256B	Reads: 0, writes: no effect
RTI + DWWD	PPS7	0xFFFFFC00	0xFFFFFCFF	256B	256B	Reads: 0, writes: no effect
VIM Parity	PPS7	0xFFFFFD00	0xFFFFFDFF	256B	256B	Reads: 0, writes: no effect
VIM	PPS7	0xFFFFFE00	0xFFFFFEFF	256B	256B	Reads: 0, writes: no effect
System Module - Frame 1 (see device TRM)	PPS7	0xFFFFF000	0xFFFFF0FF	256B	256B	Reads: 0, writes: no effect

6.9.3 Master/Slave Access Privileges

Table 6-21 lists the access permissions for each bus master on the device. A bus master is a module that can initiate a read or a write transaction on the device.

Each slave module on the main interconnect is listed in the table. A "Yes" indicates that the module listed in the "MASTERS" column can access that slave module.

Table 6-21. Master / Slave Access Matrix

MASTERS	ACCESS MODE	SLAVES ON MAIN SCR				
		Flash Module Bus2 Interface: OTP, ECC, EEPROM Bank	Non-CPU Accesses to Program Flash and CPU Data RAM	CRC	EMIF, Ethernet, USB Slave Interfaces	Peripheral Control Registers, All Peripheral Memories, And All System Module Control Registers And Memories
CPU READ	User/Privilege	Yes	Yes	Yes	Yes	Yes
CPU WRITE	User/Privilege	No	Yes	Yes	Yes	Yes
DMA	User	Yes	Yes	Yes	Yes	Yes
POM	User	Yes	Yes	Yes	Yes	Yes
DMM	User	Yes	Yes	Yes	Yes	Yes
DAP	Privilege	Yes	Yes	Yes	Yes	Yes
HTU1	Privilege	No	Yes	Yes	Yes	Yes
HTU2	Privilege	No	Yes	Yes	Yes	Yes
EMAC DMA	User	No	Yes	No	Yes	No
OHCI	User	No	Yes	No	Yes	No

6.9.3.1 Special Notes on Accesses to Certain Slaves

Write accesses to the Power Domain Management Module (PMM) control registers are limited to the CPU (master id = 1). The other masters can only read from these registers.

A debugger can also write to the PMM registers. The master-id check is disabled in debug mode.

The device contains dedicated logic to generate a bus error response on any access to a module that is in a power domain that has been turned OFF.

6.9.4 POM Overlay Considerations

- The POM overlay can map onto up to 8MB of the internal or external memory space. The starting address and the size of the memory overlay are configurable via the POM module control registers. Care must be taken to ensure that the overlay is mapped on to available memory.
- ECC must be disabled by software via CP15 in case POM overlay is enabled; otherwise ECC errors will be generated.
- POM overlay must not be enabled when the flash and internal RAM memories are swapped via the MEM SWAP field of the Bus Matrix Module Control Register 1 (BMMCR1).
- When POM is used to overlay the flash onto internal or external RAM, there is a bus contention possibility when another master accesses the TCM flash. This results in a system hang.
 - The POM module implements a time-out feature to detect this exact scenario. The time-out needs to be enabled whenever POM overlay is enabled.
 - The time-out can be enabled by writing 1010 to the Enable TimeOut (ETO) field of the POM Global Control register (POMGLBCTRL, address = 0xFFA04000).
 - In case a read request by the POM cannot be completed within 32 HCLK cycles, the time-out (TO) flag is set in the POM Flag register (POMFLG, address = 0xFFA0400C). Also, an abort is generated to the CPU. This can be a prefetch abort for an instruction fetch or a data abort for a data fetch.
 - The prefetch- and data-abort handlers must be modified to check if the TO flag in the POM module is set. If so, then the application can assume that the time-out is caused by a bus contention between the POM transaction and another master accessing the same memory region. The abort handlers need to clear the TO flag, so that any further aborts are not misinterpreted as having been caused due to a time-out from the POM.

6.10 Flash Memory

6.10.1 Flash Memory Configuration

Flash Bank: A separate block of logic consisting of 1 to 16 sectors. Each flash bank normally has a customer-OTP and a TI-OTP area. These flash sectors share input/output buffers, data paths, sense amplifiers, and control logic.

Flash Sector: A contiguous region of flash memory which must be erased simultaneously due to physical construction constraints.

Flash Pump: A charge pump which generates all the voltages required for reading, programming, or erasing the flash banks.

Flash Module: Interface circuitry required between the host CPU and the flash banks and pump module.

Table 6-22. Flash Memory Banks and Sectors

MEMORY ARRAYS (OR BANKS) ⁽¹⁾	SECTOR NO.	SEGMENT (BYTES)	LOW ADDRESS	HIGH ADDRESS
BANK0 (1.5MB)	0	32KB	0x0000_0000	0x0000_7FFF
	1	32KB	0x0000_8000	0x0000_FFFF
	2	32KB	0x0001_0000	0x0001_7FFF
	3	32KB	0x0001_8000	0x0001_FFFF
	4	128KB	0x0002_0000	0x0003_FFFF
	5	128KB	0x0004_0000	0x0005_FFFF
	6	128KB	0x0006_0000	0x0007_FFFF
	7	128KB	0x0008_0000	0x0009_FFFF
	8	128KB	0x000A_0000	0x000B_FFFF
	9	128KB	0x000C_0000	0x000D_FFFF
	10	128KB	0x000E_0000	0x000F_FFFF
	11	128KB	0x0010_0000	0x0011_FFFF
	12	128KB	0x0012_0000	0x0013_FFFF
	13	128KB	0x0014_0000	0x0015_FFFF
BANK1 (1.5MB)	0	128KB	0x0018_0000	0x0019_FFFF
	1	128KB	0x001A_0000	0x001B_FFFF
	2	128KB	0x001C_0000	0x001D_FFFF
	3	128KB	0x001E_0000	0x001F_FFFF
(3MB devices only)	4	128KB	0x0020_0000	0x0021_FFFF
	5	128KB	0x0022_0000	0x0023_FFFF
	6	128KB	0x0024_0000	0x0025_FFFF
	7	128KB	0x0026_0000	0x0027_FFFF
	8	128KB	0x0028_0000	0x0029_FFFF
	9	128KB	0x002A_0000	0x002B_FFFF
	10	128KB	0x002C_0000	0x002D_FFFF
	11	128KB	0x002E_0000	0x002F_FFFF
BANK7 (64KB) for EEPROM emulation ⁽²⁾⁽³⁾	0	16KB	0xF020_0000	0xF020_3FFF
	1	16KB	0xF020_4000	0xF020_7FFF
	2	16KB	0xF020_8000	0xF020_BFFF
	3	16KB	0xF020_C000	0xF020_FFFF

(1) The Flash banks are 144-bit-wide bank with ECC support.

(2) The flash bank7 can be programmed while executing code from flash bank0 or bank1.

(3) Code execution is not allowed from flash bank7.

6.10.2 Main Features of Flash Module

- Support for multiple flash banks for program and/or data storage
- Simultaneous read access on a bank while performing program or erase operation on any other bank
- Integrated state machines to automate flash erase and program operations
- Software interface for flash program and erase operations
- Pipelined mode operation to improve instruction access interface bandwidth
- Support for Single Error Correction Double Error Detection (SECCDED) block inside Cortex-R4F CPU
 - Error address is captured for host system debugging
- Support for a rich set of diagnostic features

6.10.3 ECC Protection for Flash Accesses

All accesses to the program flash memory are protected by Single Error Correction Double Error Detection (SECCDED) logic embedded inside the CPU. The flash module provides 8 bits of ECC code for 64 bits of instructions or data fetched from the flash memory. The CPU calculates the expected ECC code based on the 64 bits received and compares it with the ECC code returned by the flash module. A single-bit error is corrected and flagged by the CPU, while a multibit error is only flagged. The CPU signals an ECC error via its Event bus. This signaling mechanism is not enabled by default and must be enabled by setting the 'X' bit of the Performance Monitor Control Register, c9.

```
MRC p15, #0, r1, c9, c12, #0      ;Enabling Event monitor states
ORR r1, r1, #0x00000010
MCR p15, #0, r1, c9, c12, #0      ;Set 4th bit ('X') of PMNC register
MRC p15, #0, r1, c9, c12, #0
```

The application must also explicitly enable the CPU's ECC checking for accesses on the CPU's ATCM and BTCM interfaces. These are connected to the program flash and data RAM respectively. ECC checking for these interfaces can be done by setting the B1TCMPCEN, B0TCMPCEN and ATCMPCEN bits of the System Control coprocessor's Auxiliary Control Register, c1.

```
MRC p15, #0, r1, c1, c0, #1
ORR r1, r1, #0x0e000000          ;Enable ECC checking for ATCM and BTCMs
DMB
MCR p15, #0, r1, c1, c0, #1
```

6.10.4 Flash Access Speeds

For information on flash memory access speeds and the relevant wait states required, refer to [Section 5.6](#).

6.10.5 Flash Program and Erase Timings for Program Flash

Table 6-23. Timing Specifications for Program Flash

PARAMETER			MIN	NOM	MAX	UNIT
t _{prog} (144bit)	Wide Word (144bit) programming time			40	300	µs
t _{prog} (Total)	3-MB programming time ⁽¹⁾	-40°C to 105°C			32	s
		0°C to 60°C, for first 25 cycles		8	16	s
t _{erase}	Sector/Bank erase time ⁽²⁾	-40°C to 105°C		0.03	4	s
		0°C to 60°C, for first 25 cycles		16	100	ms
t _{wec}	Write/erase cycles with 15-year Data Retention requirement	-40°C to 105°C			1000	cycles

(1) This programming time includes overhead of state machine, but does not include data transfer time. The programming time assumes programming 144 bits at a time at the maximum specified operating frequency.
 (2) During bank erase, the selected sectors are erased simultaneously. The time to erase the bank is specified as equal to the time to erase a sector.

6.10.6 Flash Program and Erase Timings for Data Flash

Table 6-24. Timing Specifications for Data Flash

PARAMETER			MIN	NOM	MAX	UNIT
t_{prog} (144bit)	Wide Word (144bit) programming time			40	300	μs
t_{prog} (Total)	64-KB programming time ⁽¹⁾	-40°C to 105°C			660	ms
		0°C to 60°C, for first 25 cycles		165	330	ms
t_{erase}	Sector/Bank erase time ⁽²⁾	-40°C to 105°C		0.2	8	s
		0°C to 60°C, for first 25 cycles		14	100	ms
t_{wec}	Write/erase cycles with 15-year Data Retention requirement	-40°C to 105°C			100000	cycles

- (1) This programming time includes overhead of state machine, but does not include data transfer time. The programming time assumes programming 144 bits at a time at the maximum specified operating frequency.
- (2) During bank erase, the selected sectors are erased simultaneously. The time to erase the bank is specified as equal to the time to erase a sector.

6.11 Tightly Coupled RAM (TCRAM) Interface Module

Figure 6-10 illustrates the connection of the Tightly Coupled RAM (TCRAM) to the Cortex-R4F CPU.

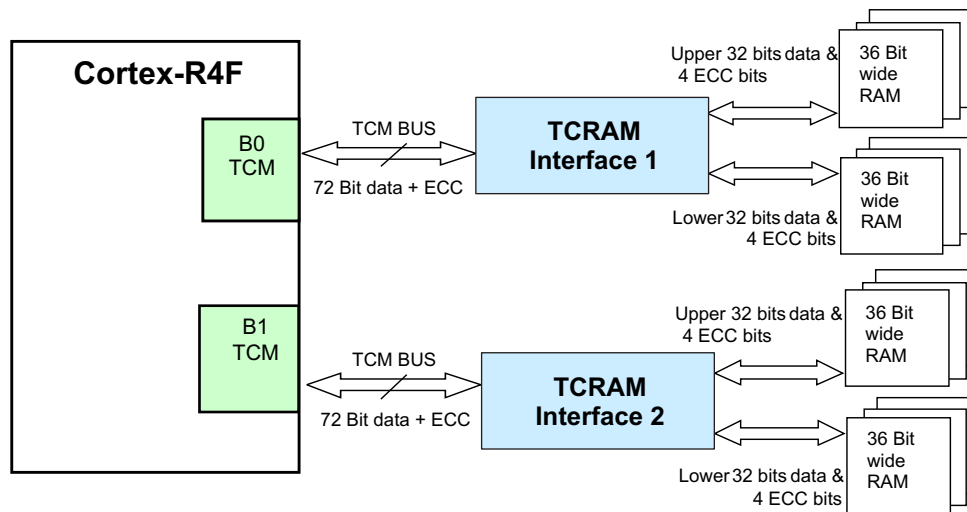

Figure 6-10. TCRAM Block Diagram

6.11.1 Features

The features of the TCRAM Module are:

- Acts as slave to the Cortex-R4F CPU's BTCM interface
- Supports CPU's internal ECC scheme by providing 64-bit data and 8-bit ECC code
- Monitors CPU Event Bus and generates single or multibit error interrupts
- Stores addresses for single and multibit errors
- Supports RAM trace module
- Provides CPU address bus integrity checking by supporting parity checking on the address bus
- Performs redundant address decoding for the RAM bank chip select and ECC select generation logic
- Provides enhanced safety for the RAM addressing by implementing two 36-bit wide byte-interleaved RAM banks and generating independent RAM access control signals to the two banks
- Supports auto-initialization of the RAM banks along with the ECC bits

6.11.2 TCRAM Interface ECC Support

The TCRAM interface passes on the ECC code for each data read by the Cortex-R4F CPU from the RAM. It also stores the CPU's ECC port contents in the ECC RAM when the CPU does a write to the RAM. The TCRAM interface monitors the CPU's event bus and provides registers for indicating singlebit or multibit errors and also for identifying the address that caused the single or multibit error. The event signaling and the ECC checking for the RAM accesses must be enabled inside the CPU.

For more information see the device specific technical reference manual.

6.12 Parity Protection for Peripheral RAMs

Most peripheral RAMs are protected by odd/even parity checking. During a read access the parity is calculated based on the data read from the peripheral RAM and compared with the good parity value stored in the parity RAM for that peripheral. If any word fails the parity check, the module generates a parity error signal that is mapped to the Error Signaling Module. The module also captures the peripheral RAM address that caused the parity error.

The parity protection for peripheral RAMs is not enabled by default and must be enabled by the application. Each individual peripheral contains control registers to enable the parity protection for accesses to its RAM.

NOTE

The CPU read access gets the actual data from the peripheral. The application can choose to generate an interrupt whenever a peripheral RAM parity error is detected.

6.13 On-Chip SRAM Initialization and Testing

6.13.1 On-Chip SRAM Self-Test Using PBIST

6.13.1.1 Features

- Extensive instruction set to support various memory test algorithms
- ROM-based algorithms allow application to run TI production-level memory tests
- Independent testing of all on-chip SRAM

6.13.1.2 PBIST RAM Groups

Table 6-25. PBIST RAM Grouping

MEMORY	RAM GROUP	TEST CLOCK	MEM TYPE	TEST PATTERN (ALGORITHM)			
				TRIPLE READ SLOW READ	TRIPLE READ FAST READ	MARCH 13N ⁽¹⁾ TWO PORT (CYCLES)	MARCH 13N ⁽¹⁾ SINGLE PORT (CYCLES)
				ALGO MASK 0x1	ALGO MASK 0x2	ALGO MASK 0x4	ALGO MASK 0x8
PBIST_ROM	1	ROM CLK	ROM	24578	8194		
STC_ROM	2	ROM CLK	ROM	19586	6530		
DCAN1	3	VCLK	Dual Port			25200	
DCAN2	4	VCLK	Dual Port			25200	
DCAN3	5	VCLK	Dual Port			25200	
ESRAM1 ⁽²⁾	6	HCLK	Single Port				266280
MIBSPI1	7	VCLK	Dual Port			33440	
MIBSPI3	8	VCLK	Dual Port			33440	
MIBSPI5	9	VCLK	Dual Port			33440	
VIM	10	VCLK	Dual Port			12560	
MIBADC1	11	VCLK	Dual Port			4200	
DMA	12	HCLK	Dual Port			18960	
N2HET1	13	VCLK	Dual Port			31680	
HTU1	14	VCLK	Dual Port			6480	
RTP	15	HCLK	Dual Port			37800	
MIBADC2	18	VCLK	Dual Port			4200	
N2HET2	19	VCLK	Dual Port			31680	
HTU2	20	VCLK	Dual Port			6480	
ESRAM5 ⁽³⁾	21	HCLK	Single Port				266280
ESRAM6 ⁽⁴⁾	22	HCLK	Single Port				266280
ETHERNET	23	VCLK3	Dual Port			8700	
	24				6360		
	25		Single Port				133160
USB	26	VCLK3	Dual Port			4240	
	27		Single Port				66600
ESRAM8 ⁽⁵⁾	28	HCLK	Single Port				266280

(1) There are several memory testing algorithms stored in the PBIST ROM. However, TI recommends the March13N algorithm for application testing.

(2) ESRAM1: Address 0x08000000 - 0x0800FFFF (Always on power domain)

(3) ESRAM5: Address 0x08010000 - 0x0801FFFF (RAM power domain 1)

(4) ESRAM6: Address 0x08020000 - 0x0802FFFF (RAM power domain 2)

(5) ESRAM8: Address 0x08030000 - 0x0803FFFF (RAM power domain 3)

The PBIST ROM clock frequency is limited to 110 MHz, if $110 \text{ MHz} < \text{HCLK} \leq \text{HCLKmax}$, or HCLK , if $\text{HCLK} \leq 110 \text{ MHz}$.

The PBIST ROM clock is divided down from HCLK. The divider is selected by programming the ROM_DIV field of the Memory Self-Test Global Control Register (MSTGCR) at address 0xFFFFF58.

6.13.2 On-Chip SRAM Auto Initialization

This microcontroller allows some of the on-chip memories to be initialized to zero via the Memory Hardware Initialization mechanism in the System module. This hardware mechanism allows an application to program the memory arrays with error detection capability to a known state based on their error detection scheme (odd/even parity or ECC).

The MINITGCR register enables the memory initialization sequence, and the MSINENA register selects the memories that are to be initialized.

For more information on these registers see the device specific technical reference manual.

The mapping of the different on-chip memories to the specific bits of the MSINENA registers is shown in [Table 6-26](#).

Table 6-26. Memory Initialization

CONNECTING MODULE	ADDRESS RANGE		MSINENA REGISTER BIT #
	BASE ADDRESS	ENDING ADDRESS	
RAM (PD#1)	0x08000000	0x0800FFFF	0 ⁽¹⁾
RAM (RAM_PD#1)	0x08010000	0x0801FFFF	0 ⁽¹⁾
RAM (RAM_PD#2)	0x08020000	0x0802FFFF	0 ⁽¹⁾
RAM (RAM_PD#3)	0x08030000	0x0803FFFF	0 ⁽¹⁾
MIBSPI5 RAM	0xFF0A0000	0xFF0BFFFF	12 ⁽²⁾
MIBSPI3 RAM	0xFF0C0000	0xFF0DFFFF	11 ⁽²⁾
MIBSPI1 RAM	0xFF0E0000	0xFF0FFFFF	7 ⁽²⁾
DCAN3 RAM	0xFF1A0000	0xFF1BFFFF	10
DCAN2 RAM	0xFF1C0000	0xFF1DFFFF	6
DCAN1 RAM	0xFF1E0000	0xFF1FFFFF	5
MIBADC2 RAM	0xFF3A0000	0xFF3BFFFF	14
MIBADC1 RAM	0xFF3E0000	0xFF3FFFFF	8
N2HET2 RAM	0xFF440000	0xFF45FFFF	15
N2HET1 RAM	0xFF460000	0xFF47FFFF	3
HTU2 RAM	0xFF4C0000	0xFF4DFFFF	16
HTU1 RAM	0xFF4E0000	0xFF4FFFFF	4
DMA RAM	0xFFF80000	0xFFF80FFF	1
VIM RAM	0xFFF82000	0xFFF82FFF	2
USB Device RAM	RAM is not CPU-Addressable		n/a
Ethernet RAM (CPPI Memory Slave)	0xFC520000	0xFC521FFF	n/a

(1) The TCM RAM wrapper has separate control bits to select the RAM power domain that is to be auto-initialized.

(2) The MibSPIx modules perform an initialization of the transmit and receive RAMs as soon as the module is released from its local reset via the SPIGCR0 register. This is independent of whether the application chooses to initialize the MibSPIx RAMs using the system module auto-initialization method. Before the MibSPI RAM can be initialized using the system module auto-initialization method: (i) The module must be released from its local reset, AND (ii) The application must poll for the "BUF INIT ACTIVE" status flag in the SPIFLG register to become cleared (zero)

6.14 External Memory Interface (EMIF)

6.14.1 Features

The EMIF includes many features to enhance the ease and flexibility of connecting to external asynchronous memories or SDRAM devices. The EMIF features includes support for:

- 3 addressable chip select for asynchronous memories of up to 16MB each
- 1 addressable chip select space for SDRAMs up to 128MB
- 8- or 16-bit data bus width
- Programmable cycle timings such as setup, strobe, and hold times as well as turnaround time
- Select strobe mode
- Extended Wait mode
- Data bus parking

6.14.2 Electrical and Timing Specifications

6.14.2.1 Asynchronous RAM

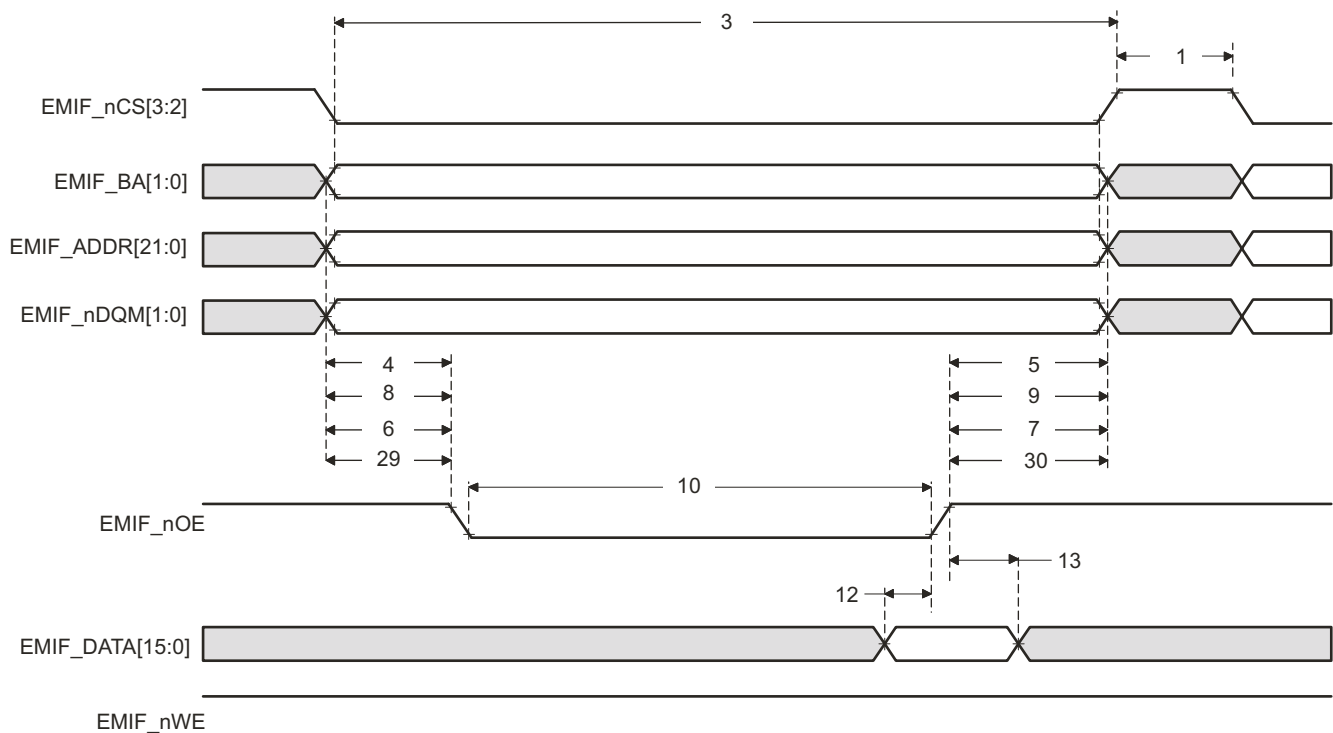

Figure 6-11. Asynchronous Memory Read Timing

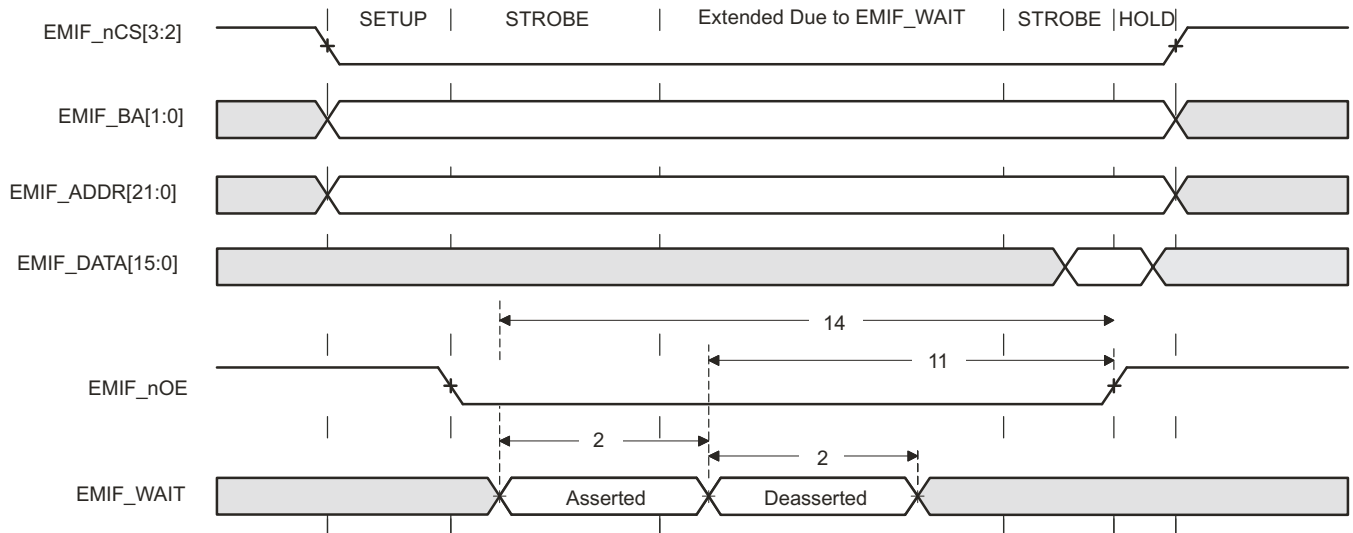

Figure 6-12. EMIFnWAIT Read Timing Requirements

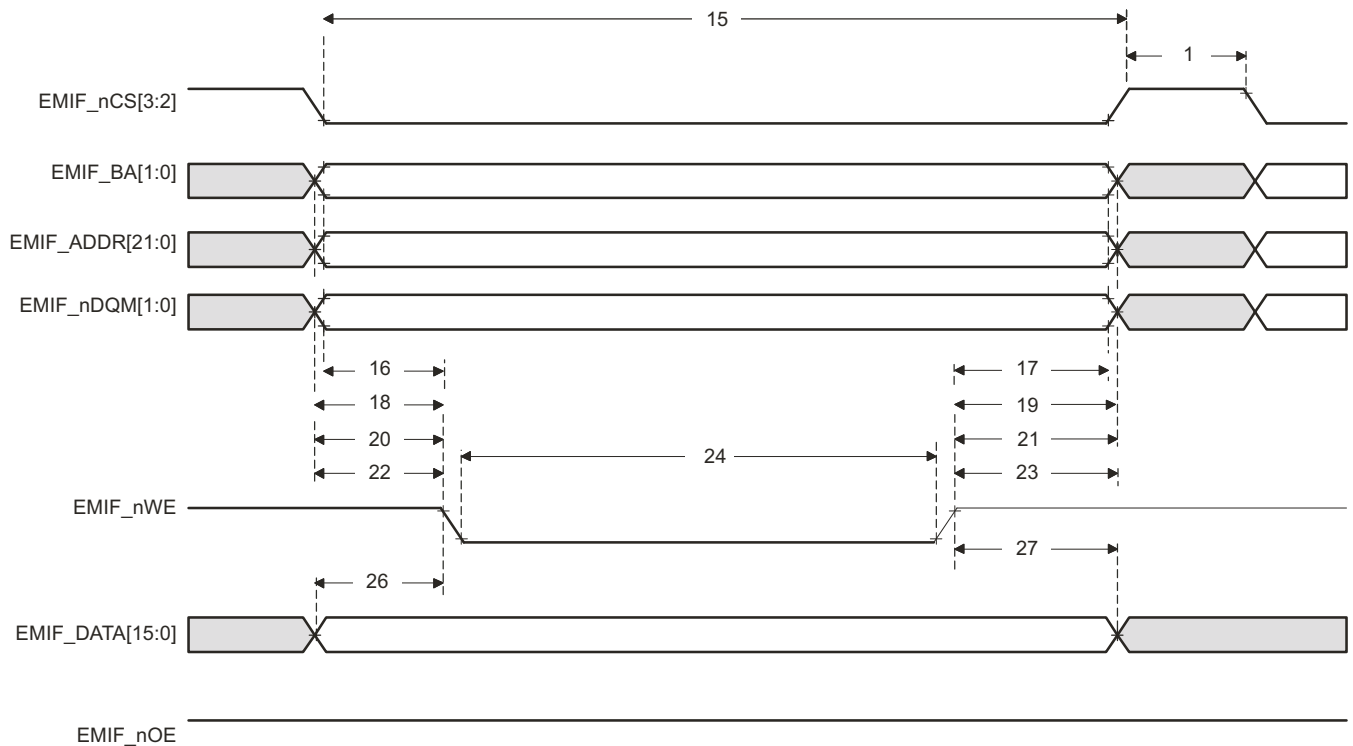

Figure 6-13. Asynchronous Memory Write Timing

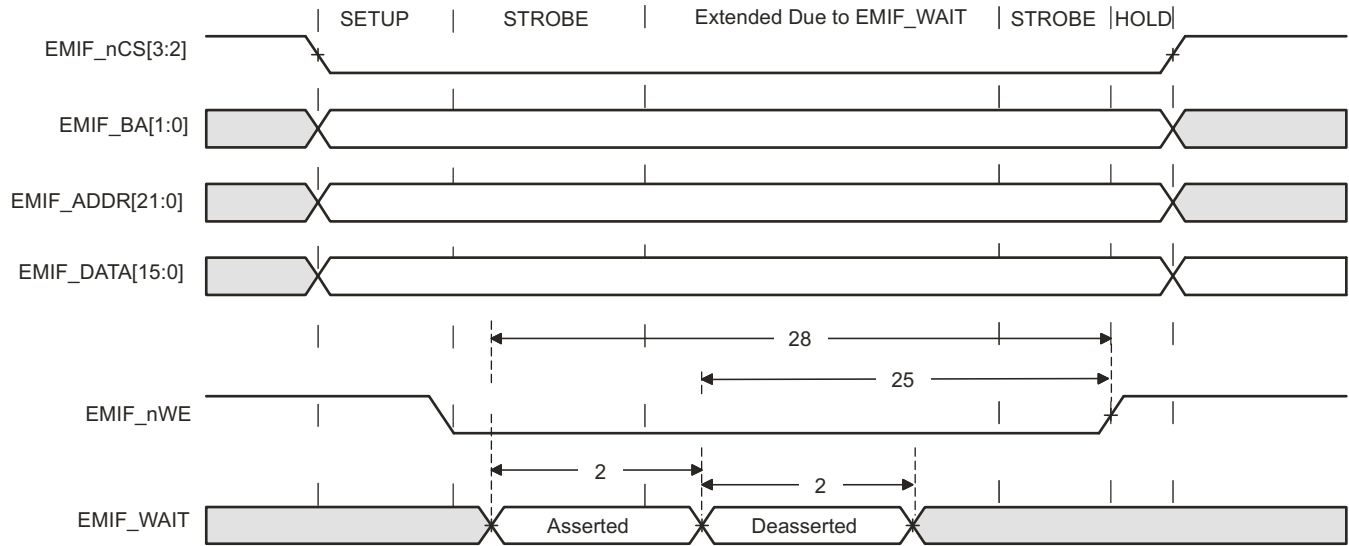

Figure 6-14. EMIFnWAIT Write Timing Requirements

Table 6-27. EMIF Asynchronous Memory Timing Requirements

NO.			MIN	NOM	MAX	UNIT
Reads and Writes						
	E	EMIF clock period	9			ns
2	$t_{w(EM_WAIT)}$	Pulse duration, EMIFnWAIT assertion and deassertion	2E			ns
Reads						
12	$t_{su(EMDV-EMOEH)}$	Setup time, EMIFDATA[15:0] valid before EMIFnOE high	30			ns
13	$t_h(EMOEH-EMDIV)$	Hold time, EMIFDATA[15:0] valid after EMIFnOE high	0.5			ns
14	$t_{su(EMOEL-EMWAIT)}$	Setup Time, EMIFnWAIT asserted before end of Strobe Phase ⁽¹⁾	4E+30			ns
Writes						
28	$t_{su(EMWEL-EMWAIT)}$	Setup Time, EMIFnWAIT asserted before end of Strobe Phase ⁽¹⁾	4E+30			ns

(1) Setup before end of STROBE phase (if no extended wait states are inserted) by which EMIFnWAIT must be asserted to add extended wait states. Figure Figure 6-12 and Figure Figure 6-14 describe EMIF transactions that include extended wait states inserted during the STROBE phase. However, cycles inserted as part of this extended wait period should not be counted; the 4E requirement is to the start of where the HOLD phase would begin if there were no extended wait cycles.

Table 6-28. EMIF Asynchronous Memory Switching Characteristics⁽¹⁾⁽²⁾⁽³⁾

NO.	PARAMETER		MIN	NOM	MAX	UNIT
Reads and Writes						
1	$t_d(TURNAROUND)$	Turn around time	(TA)*E - 4	(TA)*E	(TA)*E + 3	ns
Reads						

(1) TA = Turn around, RS = Read setup, RST = Read strobe, RH = Read hold, WS = Write setup, WST = Write strobe, WH = Write hold, MEWC = Maximum external wait cycles. These parameters are programmed via the Asynchronous Bank and Asynchronous Wait Cycle Configuration Registers. These support the following ranges of values: TA[4–1], RS[16–1], RST[64–1], RH[8–1], WS[16–1], WST[64–1], WH[8–1], and MEWC[1–256]. See the RM48x Technical Reference Manual (SPNU503) for more information.

(2) E = EMIF_CLK period in ns.

(3) EWC = external wait cycles determined by EMIFnWAIT input signal. EWC supports the following range of values. EWC[256–1]. Note that the maximum wait time before time-out is specified by bit field MEWC in the Asynchronous Wait Cycle Configuration Register. See the RM48x Technical Reference Manual (SPNU503) for more information.

Table 6-28. EMIF Asynchronous Memory Switching Characteristics⁽¹⁾⁽²⁾⁽³⁾ (continued)

NO.	PARAMETER	MIN	NOM	MAX	UNIT	
3	$t_{c(EMRCYCLE)}$	EMIF read cycle time (EW = 0)	$(RS+RST+RH) \cdot E - 3$	$(RS+RST+RH) \cdot E$	$(RS+RST+RH) \cdot E + 3$	ns
		EMIF read cycle time (EW = 1)	$(RS+RST+RH+(EWC \cdot 16)) \cdot E - 3$	$(RS+RST+RH+(EWC \cdot 16)) \cdot E$	$(RS+RST+RH+(EWC \cdot 16)) \cdot E + 3$	ns
4	$t_{su(EMCEL-EMOEL)}$	Output setup time, EMIFnCS[4:2] low to EMIFnOE low (SS = 0)	$(RS) \cdot E - 4$	$(RS) \cdot E$	$(RS) \cdot E + 3$	ns
		Output setup time, EMIFnCS[4:2] low to EMIFnOE low (SS = 1)	-3	0	+3	ns
5	$t_h(EMOEH-EMCEH)$	Output hold time, EMIFnOE high to EMIFnCS[4:2] high (SS = 0)	$(RH) \cdot E - 4$	$(RH) \cdot E$	$(RH) \cdot E + 3$	ns
		Output hold time, EMIFnOE high to EMIFnCS[4:2] high (SS = 1)	-3	0	+3	ns
6	$t_{su(EMBAV-EMOEL)}$	Output setup time, EMIFBA[1:0] valid to EMIFnOE low	$(RS) \cdot E - 4$	$(RS) \cdot E$	$(RS) \cdot E + 3$	ns
7	$t_h(EMOEH-EMBAIV)$	Output hold time, EMIFnOE high to EMIFBA[1:0] invalid	$(RH) \cdot E - 4$	$(RH) \cdot E$	$(RH) \cdot E + 3$	ns
8	$t_{su(EMAV-EMOEL)}$	Output setup time, EMIFADDR[21:0] valid to EMIFnOE low	$(RS) \cdot E - 4$	$(RS) \cdot E$	$(RS) \cdot E + 3$	ns
9	$t_h(EMOEH-EMAIV)$	Output hold time, EMIFnOE high to EMIFADDR[21:0] invalid	$(RH) \cdot E - 4$	$(RH) \cdot E$	$(RH) \cdot E + 3$	ns
10	$t_w(EMOEL)$	EMIFnOE active low width (EW = 0)	$(RST) \cdot E - 3$	$(RST) \cdot E$	$(RST) \cdot E + 3$	ns
		EMIFnOE active low width (EW = 1)	$(RST+(EWC \cdot 16)) \cdot E - 3$	$(RST+(EWC \cdot 16)) \cdot E$	$(RST+(EWC \cdot 16)) \cdot E + 3$	ns
11	$t_d(EMWAITH-EMOEH)$	Delay time from EMIFnWAIT deasserted to EMIFnOE high	3E-3	4E	4E+30	ns
29	$t_{su(EMDQMV-EMOEL)}$	Output setup time, EMIFnDQM[1:0] valid to EMIFnOE low	$(RS) \cdot E - 4$	$(RS) \cdot E$	$(RS) \cdot E + 3$	ns
30	$t_h(EMOEH-EMDQMIV)$	Output hold time, EMIFnOE high to EMIFnDQM[1:0] invalid	$(RH) \cdot E - 4$	$(RH) \cdot E$	$(RH) \cdot E + 3$	ns
Writes						
15	$t_{c(EMWCYCLE)}$	EMIF write cycle time (EW = 0)	$(WS+WST+WH) \cdot E - 3$	$(WS+WST+WH) \cdot E$	$(WS+WST+WH) \cdot E + 3$	ns
		EMIF write cycle time (EW = 1)	$(WS+WST+WH+(EWC \cdot 16)) \cdot E - 3$	$(WS+WST+WH+(EWC \cdot 16)) \cdot E$	$(WS+WST+WH+(EWC \cdot 16)) \cdot E + 3$	ns
16	$t_{su(EMCEL-EMWEL)}$	Output setup time, EMIFnCS[4:2] low to EMIFnWE low (SS = 0)	$(WS) \cdot E - 4$	$(WS) \cdot E$	$(WS) \cdot E + 3$	ns
		Output setup time, EMIFnCS[4:2] low to EMIFnWE low (SS = 1)	-4	0	+3	ns
17	$t_h(EMWEH-EMCEH)$	Output hold time, EMIFnWE high to EMIFnCS[4:2] high (SS = 0)	$(WH) \cdot E - 4$	$(WH) \cdot E$	$(WH) \cdot E + 3$	ns
		Output hold time, EMIFnWE high to EMIFCS[4:2] high (SS = 1)	-4	0	+3	ns
18	$t_{su(EMDQMV-EMWEL)}$	Output setup time, EMIFBA[1:0] valid to EMIFnWE low	$(WS) \cdot E - 4$	$(WS) \cdot E$	$(WS) \cdot E + 3$	ns
19	$t_h(EMWEH-EMDQMIV)$	Output hold time, EMIFnWE high to EMIFBA[1:0] invalid	$(WH) \cdot E - 4$	$(WH) \cdot E$	$(WH) \cdot E + 3$	ns
20	$t_{su(EMBAV-EMWEL)}$	Output setup time, EMIFBA[1:0] valid to EMIFnWE low	$(WS) \cdot E - 4$	$(WS) \cdot E$	$(WS) \cdot E + 3$	ns
21	$t_h(EMWEH-EMBAIV)$	Output hold time, EMIFnWE high to EMIFBA[1:0] invalid	$(WH) \cdot E - 4$	$(WH) \cdot E$	$(WH) \cdot E + 3$	ns
22	$t_{su(EMAV-EMWEL)}$	Output setup time, EMIFADDR[21:0] valid to EMIFnWE low	$(WS) \cdot E - 4$	$(WS) \cdot E$	$(WS) \cdot E + 3$	ns

Table 6-28. EMIF Asynchronous Memory Switching Characteristics⁽¹⁾⁽²⁾⁽³⁾ (continued)

NO.	PARAMETER	MIN	NOM	MAX	UNIT
23	$t_{h(EMWEH-EMAIV)}$	$(WH)*E-4$	$(WH)*E$	$(WH)*E+3$	ns
24	$t_{w(EMWEL)}$	$(WST)*E-3$	$(WST)*E$	$(WST)*E+3$	ns
	EMIFnWE active low width (EW = 1)	$(WST+(EWC*16)) *E-3$	$(WST+(EWC*16)) *E$	$(WST+(EWC*16)) *E+3$	ns
25	$t_{d(EMWAITH-EMWEH)}$	$3E-4$	$4E$	$4E+30$	ns
26	$t_{su(EMDV-EMWEL)}$	$(WS)*E-4$	$(WS)*E$	$(WS)*E+3$	ns
27	$t_{h(EMWEH-EMDIV)}$	$(WH)*E-4$	$(WH)*E$	$(WH)*E+3$	ns
31	$t_{su(EMDQMV-EMWEL)}$	$(WH)*E-4$	$(WH)*E$	$(WH)*E+3$	ns
32	$t_{h(EMWEH-EMDQIV)}$	$(WH)*E-4$	$(WH)*E$	$(WH)*E+3$	ns

6.14.2.2 Synchronous Timing

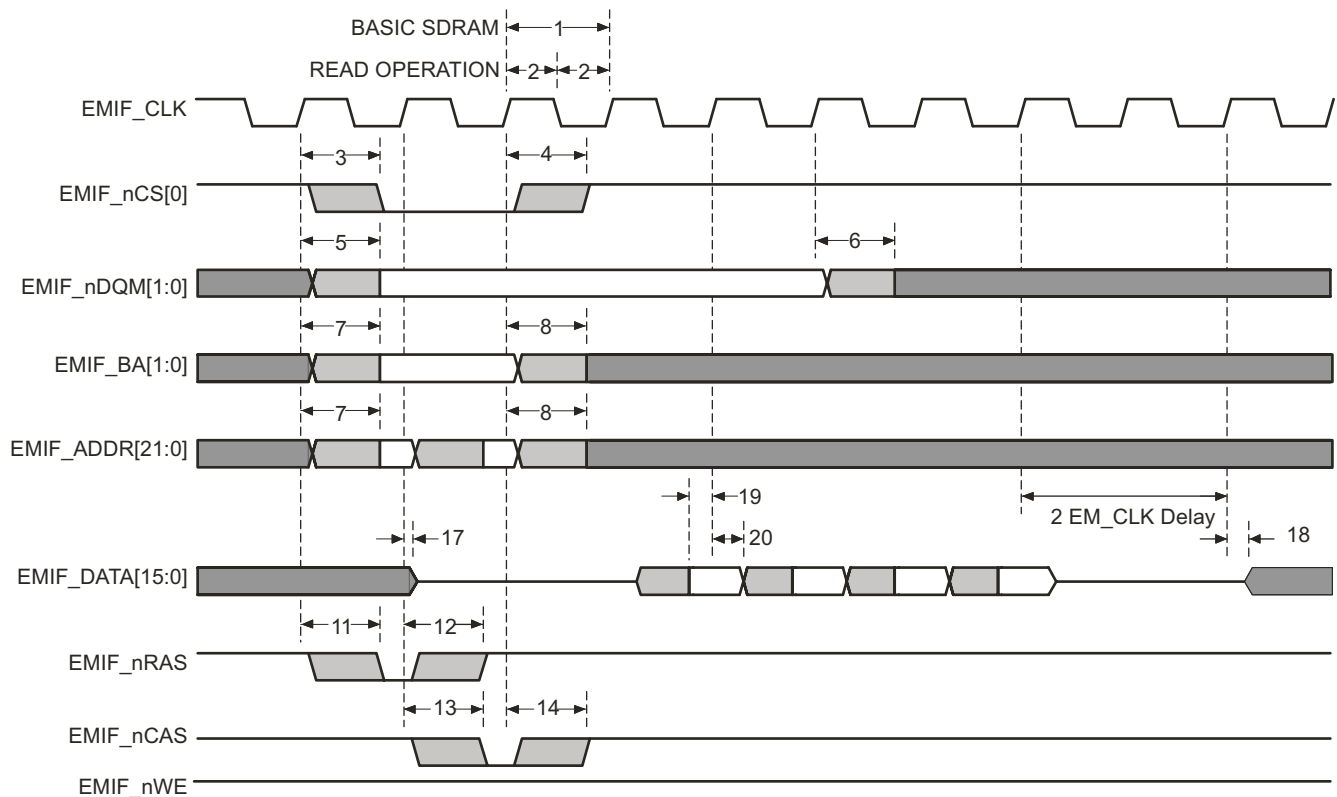

Figure 6-15. Basic SDRAM Read Operation

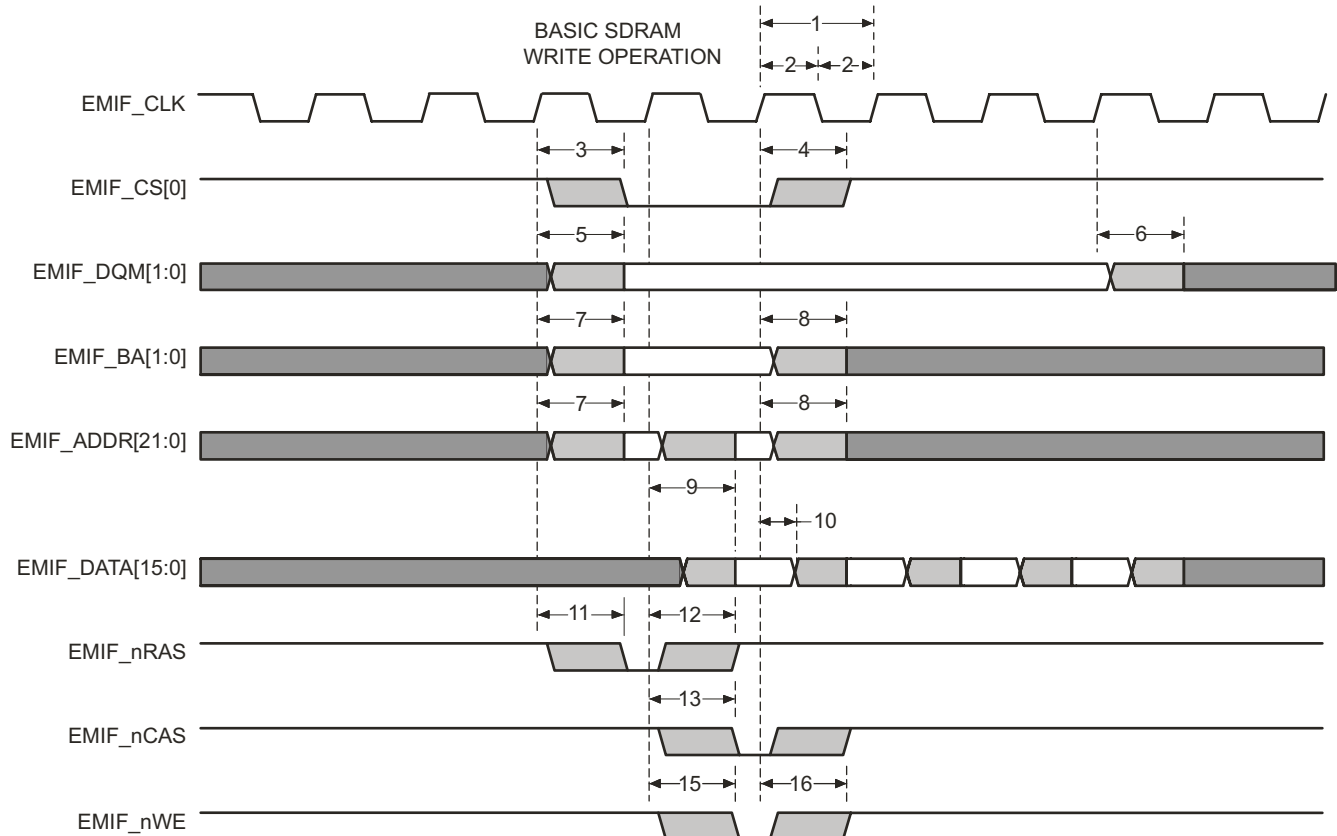

Figure 6-16. Basic SDRAM Write Operation

Table 6-29. EMIF Synchronous Memory Timing Requirements

NO.	PARAMETER	DESCRIPTION	MIN	MAX	UNIT
19	$t_{su}(EMIFDV-EM_CLKH)$	Input setup time, read data valid on EMIFDATA[15:0] before EMIF_CLK rising	2		ns
20	$t_h(CLKH-DIV)$	Input hold time, read data valid on EMIFDATA[15:0] after EMIF_CLK rising	1.5		ns

Table 6-30. EMIF Synchronous Memory Switching Characteristics

NO.	PARAMETER	DESCRIPTION	MIN	MAX	UNIT
1	$t_c(CLK)$	Cycle time, EMIF clock EMIF_CLK	18		ns
2	$t_w(CLK)$	Pulse width, EMIF clock EMIF_CLK high or low	5		ns
3	$t_d(CLKH-CSV)$	Delay time, EMIF_CLK rising to EMIFnCS[0] valid		13	ns
4	$t_{oh}(CLKH-CSIV)$	Output hold time, EMIF_CLK rising to EMIFnCS[0] invalid	1		ns
5	$t_d(CLKH-DQMV)$	Delay time, EMIF_CLK rising to EMIFnDQM[1:0] valid		13	ns
6	$t_{oh}(CLKH-DQMIV)$	Output hold time, EMIF_CLK rising to EMIFnDQM[1:0] invalid	1		ns
7	$t_d(CLKH-AV)$	Delay time, EMIF_CLK rising to EMIFADDR[21:0] and EMIFBA[1:0] valid		13	ns
8	$t_{oh}(CLKH-AIV)$	Output hold time, EMIF_CLK rising to EMIFADDR[21:0] and EMIFBA[1:0] invalid	1		ns
9	$t_d(CLKH-DV)$	Delay time, EMIF_CLK rising to EMIFDATA[15:0] valid		13	ns

Table 6-30. EMIF Synchronous Memory Switching Characteristics (continued)

NO.	PARAMETER		MIN	MAX	UNIT
10	$t_{oh}(CLKH-DIV)$	Output hold time, EMIF_CLK rising to EMIFDATA[15:0] invalid	1		ns
11	$t_d(CLKH-RASV)$	Delay time, EMIF_CLK rising to EMIFnRAS valid		13	ns
12	$t_{oh}(CLKH-RASIV)$	Output hold time, EMIF_CLK rising to EMIFnRAS invalid	1		ns
13	$t_d(CLKH-CASV)$	Delay time, EMIF_CLK rising to EMIFnCAS valid		13	ns
14	$t_{oh}(CLKH-CASIV)$	Output hold time, EMIF_CLK rising to EMIFnCAS invalid	1		ns
15	$t_d(CLKH-WEV)$	Delay time, EMIF_CLK rising to EMIFnWE valid		13	ns
16	$t_{oh}(CLKH-WEIV)$	Output hold time, EMIF_CLK rising to EMIFnWE invalid	1		ns
17	$t_{dis}(CLKH-DHZ)$	Delay time, EMIF_CLK rising to EMIFDATA[15:0] tri-stated		7	ns
18	$t_{ena}(CLKH-DLZ)$	Output hold time, EMIF_CLK rising to EMIFDATA[15:0] driving	1		ns

6.15 Vectored Interrupt Manager

The vectored interrupt manager (VIM) provides hardware assistance for prioritizing and controlling the many interrupt sources present on this device. Interrupts are caused by events outside of the normal flow of program execution. Normally, these events require a timely response from the central processing unit (CPU); therefore, when an interrupt occurs, the CPU switches execution from the normal program flow to an interrupt service routine (ISR).

6.15.1 VIM Features

The VIM module has the following features:

- Supports 96 interrupt channels.
 - Provides programmable priority and enable for interrupt request lines.
- Provides a direct hardware dispatch mechanism for fastest IRQ dispatch.
- Provides two software dispatch mechanisms when the CPU VIC port is not used.
 - Index interrupt
 - Register vectored interrupt
- Parity protected vector interrupt table

6.15.2 Interrupt Request Assignments

Table 6-31. Interrupt Request Assignments

MODULES	INTERRUPT SOURCES	DEFAULT VIM INTERRUPT CHANNEL
ESM	ESM High level interrupt (NMI)	0
Reserved	Reserved	1
RTI	RTI compare interrupt 0	2
RTI	RTI compare interrupt 1	3
RTI	RTI compare interrupt 2	4
RTI	RTI compare interrupt 3	5
RTI	RTI overflow interrupt 0	6
RTI	RTI overflow interrupt 1	7
RTI	RTI timebase interrupt	8
GPIO	GPIO interrupt A	9
N2HET1	N2HET1 level 0 interrupt	10
HTU1	HTU1 level 0 interrupt	11
MIBSPI1	MIBSPI1 level 0 interrupt	12
LIN	LIN level 0 interrupt	13
MIBADC1	MIBADC1 event group interrupt	14
MIBADC1	MIBADC1 sw group 1 interrupt	15
DCAN1	DCAN1 level 0 interrupt	16
Reserved	Reserved	18
CRC	CRC Interrupt	19
ESM	ESM Low level interrupt	20
SYSTEM	Software interrupt (SSI)	21
CPU	PMU Interrupt	22
GPIO	GPIO interrupt B	23
N2HET1	N2HET1 level 1 interrupt	24
HTU1	HTU1 level 1 interrupt	25
MIBSPI1	MIBSPI1 level 1 interrupt	26

Table 6-31. Interrupt Request Assignments (continued)

MODULES	INTERRUPT SOURCES	DEFAULT VIM INTERRUPT CHANNEL
LIN	LIN level 1 interrupt	27
MIBADC1	MIBADC1 sw group 2 interrupt	28
DCAN1	DCAN1 level 1 interrupt	29
MIBADC1	MIBADC1 magnitude compare interrupt	31
Reserved	Reserved	32
DMA	FTCA interrupt	33
DMA	LFSA interrupt	34
DCAN2	DCAN2 level 0 interrupt	35
DMM	DMM level 0 interrupt	36
MIBSPI3	MIBSPI3 level 0 interrupt	37
MIBSPI3	MIBSPI3 level 1 interrupt	38
DMA	HBCA interrupt	39
DMA	BTCA interrupt	40
EMIF	AEMIFINT3	41
DCAN2	DCAN2 level 1 interrupt	42
DMM	DMM level 1 interrupt	43
DCAN1	DCAN1 IF3 interrupt	44
DCAN3	DCAN3 level 0 interrupt	45
DCAN2	DCAN2 IF3 interrupt	46
FPU	"OR" of the six Cortex R4F FPU Exceptions	47
Reserved	Reserved	48
SPI4	SPI4 level 0 interrupt	49
MIBADC2	MibADC2 event group interrupt	50
MIBADC2	MibADC2 sw group1 interrupt	51
Reserved	Reserved	52
MIBSPI5	MIBSPI5 level 0 interrupt	53
SPI4	SPI4 level 1 interrupt	54
DCAN3	DCAN3 level 1 interrupt	55
MIBSPI5	MIBSPI5 level 1 interrupt	56
MIBADC2	MibADC2 sw group2 interrupt	57
Reserved	Reserved	58
MIBADC2	MibADC2 magnitude compare interrupt	59
DCAN3	DCAN3 IF3 interrupt	60
FMC	FSM_DONE interrupt	61
Reserved	Reserved	62
N2HET2	N2HET2 level 0 interrupt	63
SCI	SCI level 0 interrupt	64
HTU2	HTU2 level 0 interrupt	65
I2C	I2C level 0 interrupt	66
USB Host	OHCI_INT	67
USB Device	USB_FUNC.IRQISOON	68
USB Device	USB_FUNC.IRQGENION	69
USB Device	USB_FUNC.IRQNONISOON	70
USB Device	not (USB_FUNC.DSWAKEREQON)	71
USB Device	USB_FUNC.USBRESETO	72
N2HET2	N2HET2 level 1 interrupt	73
SCI	SCI level 1 interrupt	74

Table 6-31. Interrupt Request Assignments (continued)

MODULES	INTERRUPT SOURCES	DEFAULT VIM INTERRUPT CHANNEL
HTU2	HTU2 level 1 interrupt	75
Ethernet	C0_MISC_PULSE	76
Ethernet	C0_TX_PULSE	77
Ethernet	C0_THRESH_PULSE	78
Ethernet	C0_RX_PULSE	79
HWAG1	HWA_INT_REQ_H	80
HWAG2	HWA_INT_REQ_H	81
DCC1	DCC1 done interrupt	82
DCC2	DCC2 done interrupt	83
Reserved	Reserved	84
PBIST	PBIST_DONE	85
Reserved	Reserved	86
Reserved	Reserved	87
HWAG1	HWA_INT_REQ_L	88
HWAG2	HWA_INT_REQ_L	89
Reserved	Reserved	90-95

NOTE

Address location 0x00000000 in the VIM RAM is reserved for the phantom interrupt ISR entry; therefore only request channels 0..94 can be used and are offset by 1 address in the VIM RAM.

NOTE

The lower-order interrupt channels are higher priority channels than the higher-order interrupt channels.

NOTE

The application can change the mapping of interrupt sources to the interrupt channels via the interrupt channel control registers (CHANCTRLx) inside the VIM module.

6.16 DMA Controller

The DMA controller is used to transfer data between two locations in the memory map in the background of CPU operations. Typically, the DMA is used to:

- Transfer blocks of data between external and internal data memories
- Restructure portions of internal data memory
- Continually service a peripheral

6.16.1 DMA Features

- CPU independent data transfer
- One master port - PortB (64 bits wide) that interfaces to the RM4x Memory System.
- FIFO buffer(4 entries deep and each 64 bits wide)
- Channel control information is stored in RAM protected by parity
- 16 channels with individual enable
- Channel chaining capability
- 32 peripheral DMA requests
- Hardware and Software DMA requests
- 8-, 16-, 32-, or 64-bit transactions supported
- Multiple addressing modes for source/destination (fixed, increment, offset)
- Auto-initiation
- Power-management mode
- Memory Protection with four configurable memory regions

6.16.2 Default DMA Request Map

The DMA module on this microcontroller has 16 channels and up to 32 hardware DMA requests. The module contains DREQASx registers which are used to map the DMA requests to the DMA channels. By default, channel 0 is mapped to request 0, channel 1 to request 1, and so on.

Some DMA requests have multiple sources, as shown in [Table 6-32](#). The application must ensure that only one of these DMA request sources is enabled at any time.

Table 6-32. DMA Request Line Connection

Modules	DMA Request Sources	DMA Request
MIBSPI1	MIBSPI1[1] ⁽¹⁾	DMAREQ[0]
MIBSPI1	MIBSPI1[0] ⁽²⁾	DMAREQ[1]
SPI2	SPI2 receive	DMAREQ[2]
SPI2	SPI2 transmit	DMAREQ[3]
MIBSPI1 / MIBSPI3 / DCAN2	MIBSPI1[2] / MIBSPI3[2] / DCAN2 IF3	DMAREQ[4]
MIBSPI1 / MIBSPI3 / DCAN2	MIBSPI1[3] / MIBSPI3[3] / DCAN2 IF2	DMAREQ[5]
DCAN1 / MIBSPI5	DCAN1 IF2 / MIBSPI5[2]	DMAREQ[6]
MIBADC1 / MIBSPI5	MIBADC1 event / MIBSPI5[3]	DMAREQ[7]
MIBSPI1 / MIBSPI3 / DCAN1	MIBSPI1[4] / MIBSPI3[4] / DCAN1 IF1	DMAREQ[8]
MIBSPI1 / MIBSPI3 / DCAN2	MIBSPI1[5] / MIBSPI3[5] / DCAN2 IF1	DMAREQ[9]
MIBADC1 / I2C / MIBSPI5	MIBADC1 G1 / I2C receive / MIBSPI5[4]	DMAREQ[10]
MIBADC1 / I2C / MIBSPI5	MIBADC1 G2 / I2C transmit / MIBSPI5[5]	DMAREQ[11]
RTI / MIBSPI1 / MIBSPI3	RTI DMAREQ0 / MIBSPI1[6] / MIBSPI3[6]	DMAREQ[12]
RTI / MIBSPI1 / MIBSPI3	RTI DMAREQ1 / MIBSPI1[7] / MIBSPI3[7]	DMAREQ[13]
MIBSPI3 / USB Device / MibADC2 / MIBSPI5	MIBSPI3[1] ⁽¹⁾ / USB_FUNC.DMATXREQ_ON[0] / MibADC2 event / MIBSPI5[6]	DMAREQ[14]
MIBSPI3 / USB Device / MIBSPI5	MIBSPI3[0] ⁽²⁾ / USB_FUNC.DMARXREQ_ON[0] / MIBSPI5[7]	DMAREQ[15]
MIBSPI1 / MIBSPI3 / DCAN1 / MibADC2	MIBSPI1[8] / MIBSPI3[8] / DCAN1 IF3 / MibADC2 G1	DMAREQ[16]
MIBSPI1 / MIBSPI3 / DCAN3 / MibADC2	MIBSPI1[9] / MIBSPI3[9] / DCAN3 IF1 / MibADC2 G2	DMAREQ[17]
RTI / USB Device / MIBSPI5	RTI DMAREQ2 / USB_FUNC.DMATXREQ_ON[1] / MIBSPI5[8]	DMAREQ[18]
RTI / USB Device / MIBSPI5	RTI DMAREQ3 / USB_FUNC.DMARXREQ_ON[1] / MIBSPI5[9]	DMAREQ[19]
N2HET1 / N2HET2 / DCAN3	N2HET1 DMAREQ[4] / N2HET2 DMAREQ[4] / DCAN3 IF2	DMAREQ[20]
N2HET1 / N2HET2 / DCAN3	N2HET1 DMAREQ[5] / N2HET2 DMAREQ[5] / DCAN3 IF3	DMAREQ[21]
MIBSPI1 / MIBSPI3 / MIBSPI5	MIBSPI1[10] / MIBSPI3[10] / MIBSPI5[10]	DMAREQ[22]
MIBSPI1 / MIBSPI3 / MIBSPI5	MIBSPI1[11] / MIBSPI3[11] / MIBSPI5[11]	DMAREQ[23]
N2HET1 / N2HET2 / SPI4 / MIBSPI5	N2HET1 DMAREQ[6] / N2HET2 DMAREQ[6] / SPI4 receive / MIBSPI5[12]	DMAREQ[24]
N2HET1 / N2HET2 / SPI4 / MIBSPI5	N2HET1 DMAREQ[7] / N2HET2 DMAREQ[7] / SPI4 transmit / MIBSPI5[13]	DMAREQ[25]
CRC / MIBSPI1 / MIBSPI3	CRC DMAREQ[0] / MIBSPI1[12] / MIBSPI3[12]	DMAREQ[26]
CRC / MIBSPI1 / MIBSPI3	CRC DMAREQ[1] / MIBSPI1[13] / MIBSPI3[13]	DMAREQ[27]
LIN / USB Device / MIBSPI5	LIN receive / USB_FUNC.DMATXREQ_ON[2] / MIBSPI5[14]	DMAREQ[28]
LIN / USB Device / MIBSPI5	LIN transmit / USB_FUNC.DMARXREQ_ON[2] / MIBSPI5[15]	DMAREQ[29]
MIBSPI1 / MIBSPI3 / SCI / MIBSPI5	MIBSPI1[14] / MIBSPI3[14] / SCI receive / MIBSPI5[1] ⁽¹⁾	DMAREQ[30]

(1) SPI1, SPI3, SPI5 receive in mode

(2) SPI1, SPI3, SPI5 transmit in mode

Table 6-32. DMA Request Line Connection (continued)

Modules	DMA Request Sources	DMA Request
MIBSPI1 / MIBSPI3 / SCI / MIBSPI5	MIBSPI1[15] / MIBSPI3[15] / SCI transmit / MIBSPI5[0] ⁽²⁾	DMAREQ[31]

6.17 Real Time Interrupt Module

The real-time interrupt (RTI) module provides timer functionality for operating systems and for benchmarking code. The RTI module incorporates two 64-bit counters that define the timebases needed for scheduling an operating system.

The timers also allow you to benchmark certain areas of code by reading the values of the counters at the beginning and the end of the desired code range and calculating the difference between the values.

6.17.1 Features

The RTI module has the following features:

- Two independent 64 bit counter blocks
- Four configurable compares for generating operating system ticks or DMA requests. Each event can be driven by either counter block 0 or counter block 1.
- Fast enabling/disabling of events
- Two time-stamp (capture) functions for system or peripheral interrupts, one for each counter block

6.17.2 Block Diagrams

Figure 6-17 shows a high-level block diagram for one of the two 64-bit counter blocks inside the RTI module. Both the counter blocks are identical except the Network Time Unit (NTUx) inputs are only available as time base inputs for the counter block 0.

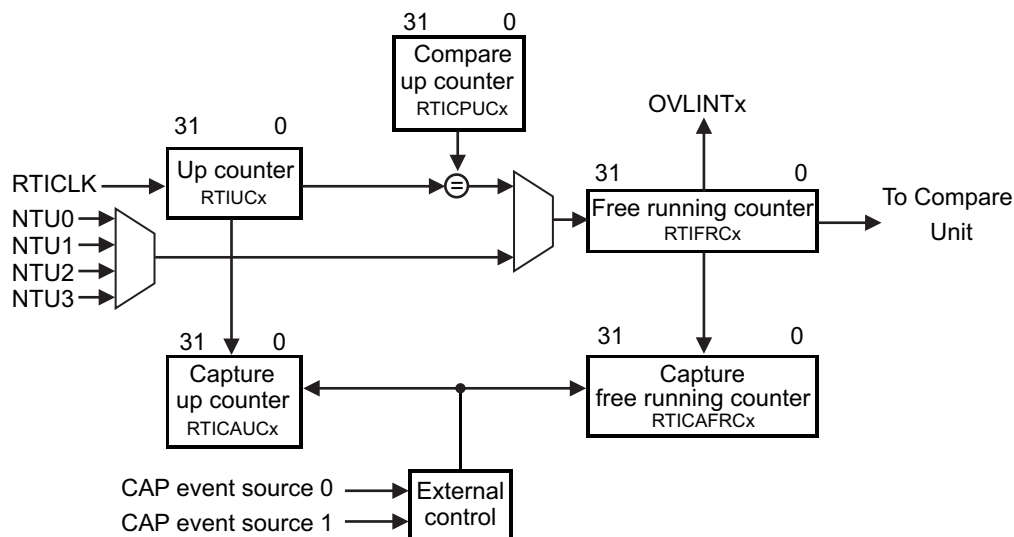

Figure 6-17. Counter Block Diagram

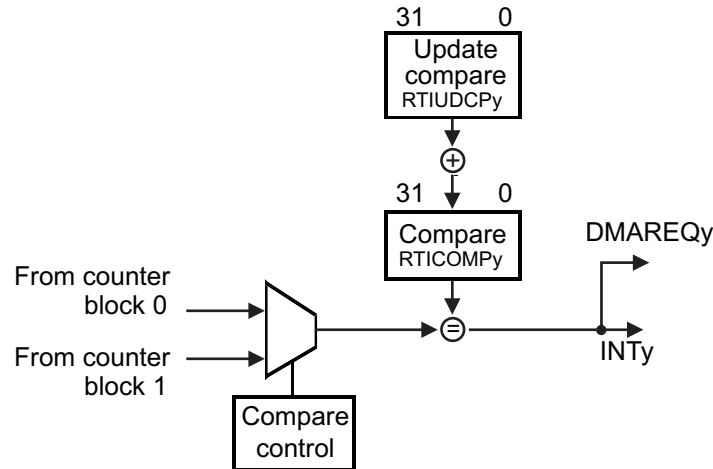

Figure 6-18. Compare Block Diagram

6.17.3 Clock Source Options

The RTI module uses the RTI1CLK clock domain for generating the RTI time bases.

The application can select the clock source for the RTI1CLK by configuring the RCLKSRC register in the System module at address 0xFFFFF50. The default source for RTI1CLK is VCLK.

For more information on clock sources refer to [Table 6-8](#) and [Table 6-13](#).

6.17.4 Network Time Synchronization Inputs

The RTI module supports 4 Network Time Unit (NTU) inputs that signal internal system events, and which can be used to synchronize the time base used by the RTI module. On this device, these NTU inputs are connected as shown in [Table 6-33](#).

Table 6-33. Network Time Synchronization Inputs

NTU Input	Source
0	Reserved
1	Reserved
2	PLL2 Clock output
3	EXTCLKIN1 clock input

6.18 Error Signaling Module

The Error Signaling Module (ESM) manages the various error conditions on the RM4x microcontroller. The error condition is handled based on a fixed severity level assigned to it. Any severe error condition can be configured to drive a low level on a dedicated device terminal called nERROR. This can be used as an indicator to an external monitor circuit to put the system into a safe state.

6.18.1 Features

The features of the Error Signaling Module are:

- 128 interrupt/error channels are supported, divided into 3 different groups
 - 64 channels with maskable interrupt and configurable error pin behavior
 - 32 error channels with nonmaskable interrupt and predefined error pin behavior
 - 32 channels with predefined error pin behavior only
- Error pin to signal severe device failure
- Configurable timebase for error signal
- Error forcing capability

6.18.2 ESM Channel Assignments

The Error Signaling Module (ESM) integrates all the device error conditions and groups them in the order of severity. Group1 is used for errors of the lowest severity while Group3 is used for errors of the highest severity. The device response to each error is determined by the severity group it is connected to. [Table 6-35](#) shows the channel assignment for each group.

Table 6-34. ESM Groups

ERROR GROUP	INTERRUPT CHARACTERISTICS	INFLUENCE ON ERROR PIN
Group1	maskable, low or high priority	configurable
Group2	nonmaskable, high priority	fixed
Group3	no interrupt generated	fixed

Table 6-35. ESM Channel Assignments

ERROR SOURCES	GROUP	CHANNELS
Reserved	Group1	0
MibADC2 - parity	Group1	1
DMA - MPU	Group1	2
DMA - parity	Group1	3
Reserved	Group1	4
DMA/DMM - imprecise read error	Group1	5
FMC - correctable error: bus1 and bus2 interfaces (does not include accesses to EEPROM bank)	Group1	6
N2HET1/N2HET2 - parity	Group1	7
HTU1/HTU2 - parity	Group1	8
HTU1/HTU2 - MPU	Group1	9
PLL - Slip	Group1	10
Clock Monitor - interrupt	Group1	11
Reserved	Group1	12
DMA/DMM - imprecise write error	Group1	13
Reserved	Group1	14
VIM RAM - parity	Group1	15
Reserved	Group1	16
MibSPI1 - parity	Group1	17
MibSPI3 - parity	Group1	18

Table 6-35. ESM Channel Assignments (continued)

ERROR SOURCES	GROUP	CHANNELS
MibADC1 - parity	Group1	19
Reserved	Group1	20
DCAN1 - parity	Group1	21
DCAN3 - parity	Group1	22
DCAN2 - parity	Group1	23
MibSPI5 - parity	Group1	24
Reserved	Group1	25
RAM even bank (B0TCM) - correctable error	Group1	26
CPU - selftest	Group1	27
RAM odd bank (B1TCM) - correctable error	Group1	28
Reserved	Group1	29
DCC1 - error	Group1	30
CCM-R4 - selftest	Group1	31
Reserved	Group1	32
Reserved	Group1	33
Reserved	Group1	34
FMC - correctable error (EEPROM bank access)	Group1	35
FMC - uncorrectable error (EEPROM bank access)	Group1	36
IOMM - Mux configuration error	Group1	37
Power domain controller compare error	Group1	38
Power domain controller self-test error	Group1	39
eFuse Controller Error – this error signal is generated when any bit in the eFuse controller error status register is set. The application can choose to generate an interrupt whenever this bit is set to service any eFuse controller error conditions.	Group1	40
eFuse Controller - Self Test Error. This error signal is generated only when a self test on the eFuse controller generates an error condition. When an ECC self test error is detected, group 1 channel 40 error signal will also be set.	Group1	41
PLL2 - Slip	Group1	42
Ethernet Controller master interface	Group1	43
USB Host Controller master interface	Group1	44
Reserved	Group1	45
Reserved	Group1	46
Reserved	Group1	47
Reserved	Group1	48
Reserved	Group1	49
Reserved	Group1	50
Reserved	Group1	51
Reserved	Group1	52
Reserved	Group1	53
Reserved	Group1	54
Reserved	Group1	55
Reserved	Group1	56
Reserved	Group1	57
Reserved	Group1	58
Reserved	Group1	59
Reserved	Group1	60
Reserved	Group1	61
DCC2 - error	Group1	62

Table 6-35. ESM Channel Assignments (continued)

ERROR SOURCES	GROUP	CHANNELS
Reserved	Group1	63
GROUP 2		
Reserved	Group2	0
Reserved	Group2	1
CCMR4 - compare	Group2	2
Reserved	Group2	3
FMC - uncorrectable error (address parity on bus1 accesses)	Group2	4
Reserved	Group2	5
RAM even bank (B0TCM) - uncorrectable error	Group2	6
Reserved	Group2	7
RAM odd bank (B1TCM) - uncorrectable error	Group2	8
Reserved	Group2	9
RAM even bank (B0TCM) - address bus parity error	Group2	10
Reserved	Group2	11
RAM odd bank (B1TCM) - address bus parity error	Group2	12
Reserved	Group2	13
Reserved	Group2	14
Reserved	Group2	15
TCM - ECC live lock detect	Group2	16
Reserved	Group2	17
Reserved	Group2	18
Reserved	Group2	19
Reserved	Group2	20
Reserved	Group2	21
Reserved	Group2	22
Reserved	Group2	23
RTI_WWD_NMI	Group2	24
Reserved	Group2	25
Reserved	Group2	26
Reserved	Group2	27
Reserved	Group2	28
Reserved	Group2	29
Reserved	Group2	30
Reserved	Group2	31
GROUP 3		
Reserved	Group3	0
eFuse Controller - autoload error	Group3	1
Reserved	Group3	2
RAM even bank (B0TCM) - ECC uncorrectable error	Group3	3
Reserved	Group3	4
RAM odd bank (B1TCM) - ECC uncorrectable error	Group3	5
Reserved	Group3	6
FMC - uncorrectable error: bus1 and bus2 interfaces (does not include address parity error and errors on accesses to EEPROM bank)	Group3	7
Reserved	Group3	8
Reserved	Group3	9
Reserved	Group3	10
Reserved	Group3	11

Table 6-35. ESM Channel Assignments (continued)

ERROR SOURCES	GROUP	CHANNELS
Reserved	Group3	12
Reserved	Group3	13
Reserved	Group3	14
Reserved	Group3	15
Reserved	Group3	16
Reserved	Group3	17
Reserved	Group3	18
Reserved	Group3	19
Reserved	Group3	20
Reserved	Group3	21
Reserved	Group3	22
Reserved	Group3	23
Reserved	Group3	24
Reserved	Group3	25
Reserved	Group3	26
Reserved	Group3	27
Reserved	Group3	28
Reserved	Group3	29
Reserved	Group3	30
Reserved	Group3	31

6.19 Reset / Abort / Error Sources

Table 6-36. Reset/Abort/Error Sources

ERROR SOURCE	SYSTEM MODE	ERROR RESPONSE	ESM HOOKUP group.channel
CPU TRANSACTIONS			
Precise write error (NCNB/Strongly Ordered)	User/Privilege	Precise Abort (CPU)	n/a
Precise read error (NCB/Device or Normal)	User/Privilege	Precise Abort (CPU)	n/a
Imprecise write error (NCB/Device or Normal)	User/Privilege	Imprecise Abort (CPU)	n/a
Illegal instruction	User/Privilege	Undefined Instruction Trap (CPU) ⁽¹⁾	n/a
MPU access violation	User/Privilege	Abort (CPU)	n/a
SRAM			
B0 TCM (even) ECC single error (correctable)	User/Privilege	ESM	1.26
B0 TCM (even) ECC double error (noncorrectable)	User/Privilege	Abort (CPU), ESM => nERROR	3.3
B0 TCM (even) uncorrectable error (for example, redundant address decode)	User/Privilege	ESM => NMI => nERROR	2.6
B0 TCM (even) address bus parity error	User/Privilege	ESM => NMI => nERROR	2.10
B1 TCM (odd) ECC single error (correctable)	User/Privilege	ESM	1.28
B1 TCM (odd) ECC double error (noncorrectable)	User/Privilege	Abort (CPU), ESM => nERROR	3.5
B1 TCM (odd) uncorrectable error (for example, redundant address decode)	User/Privilege	ESM => NMI => nERROR	2.8
B1 TCM (odd) address bus parity error	User/Privilege	ESM => NMI => nERROR	2.12
FLASH			
FMC correctable error - Bus1 and Bus2 interfaces	User/Privilege	ESM	1.6
FMC uncorrectable error - Bus1 accesses (does not include address parity error)	User/Privilege	Abort (CPU), ESM => nERROR	3.7
FMC uncorrectable error - Bus2 accesses (does not include address parity error and EEPROM bank accesses)	User/Privilege	ESM => nERROR	3.7
FMC uncorrectable error - address parity error on Bus1 accesses	User/Privilege	ESM => NMI => nERROR	2.4
FMC correctable error - Accesses to EEPROM bank	User/Privilege	ESM	1.35
FMC uncorrectable error - Accesses to EEPROM bank	User/Privilege	ESM	1.36
DMA TRANSACTIONS			
External imprecise error on read (Illegal transaction with ok response)	User/Privilege	ESM	1.5
External imprecise error on write (Illegal transaction with ok response)	User/Privilege	ESM	1.13
Memory access permission violation	User/Privilege	ESM	1.2
Memory parity error	User/Privilege	ESM	1.3
DMM TRANSACTIONS			
External imprecise error on read (Illegal transaction with ok response)	User/Privilege	ESM	1.5
External imprecise error on write (Illegal transaction with ok response)	User/Privilege	ESM	1.13
HTU1			
NCNB (Strongly Ordered) transaction with slave error response	User/Privilege	Interrupt => VIM	n/a
External imprecise error (Illegal transaction with ok response)	User/Privilege	Interrupt => VIM	n/a
Memory access permission violation	User/Privilege	ESM	1.9

(1) The Undefined Instruction TRAP is NOT detectable outside the CPU. The trap is taken only if the instruction reaches the execute stage of the CPU.

Table 6-36. Reset/Abort/Error Sources (continued)

ERROR SOURCE	SYSTEM MODE	ERROR RESPONSE	ESM HOOKUP group.channel
Memory parity error	User/Privilege	ESM	1.8
HTU2			
NCNB (Strongly Ordered) transaction with slave error response	User/Privilege	Interrupt => VIM	n/a
External imprecise error (Illegal transaction with ok response)	User/Privilege	Interrupt => VIM	n/a
Memory access permission violation	User/Privilege	ESM	1.9
Memory parity error	User/Privilege	ESM	1.8
N2HET1			
Memory parity error	User/Privilege	ESM	1.7
N2HET2			
Memory parity error	User/Privilege	ESM	1.7
ETHERNET MASTER INTERFACE			
Any error reported by slave being accessed	User/Privilege	ESM	1.43
USB HOST CONTROLLER (OHCI) MASTER INTERFACE			
Any error reported by slave being accessed	User/Privilege	ESM	1.44
MIBSPI			
MibSPI1 memory parity error	User/Privilege	ESM	1.17
MibSPI3 memory parity error	User/Privilege	ESM	1.18
MibSPI5 memory parity error	User/Privilege	ESM	1.24
MIBADC			
MibADC1 Memory parity error	User/Privilege	ESM	1.19
MibADC2 Memory parity error	User/Privilege	ESM	1.1
DCAN			
DCAN1 memory parity error	User/Privilege	ESM	1.21
DCAN2 memory parity error	User/Privilege	ESM	1.23
DCAN3 memory parity error	User/Privilege	ESM	1.22
PLL			
PLL slip error	User/Privilege	ESM	1.10
PLL #2 slip error	User/Privilege	ESM	1.42
CLOCK MONITOR			
Clock monitor interrupt	User/Privilege	ESM	1.11
DCC			
DCC1 error	User/Privilege	ESM	1.30
DCC2 error	User/Privilege	ESM	1.62
CCM-R4			
Self test failure	User/Privilege	ESM	1.31
Compare failure	User/Privilege	ESM => NMI => nERROR	2.2
VIM			
Memory parity error	User/Privilege	ESM	1.15
VOLTAGE MONITOR			
VMON out of voltage range	n/a	Reset	n/a
CPU SELFTEST (LBIST)			
CPU Selftest (LBIST) error	User/Privilege	ESM	1.27

Table 6-36. Reset/Abort/Error Sources (continued)

ERROR SOURCE	SYSTEM MODE	ERROR RESPONSE	ESM HOOKUP group.channel
PIN MULTIPLEXING CONTROL			
Mux configuration error	User/Privilege	ESM	1.37
POWER DOMAIN CONTROL			
PSCON compare error	User/Privilege	ESM	1.38
PSCON self-test error	User/Privilege	ESM	1.39
eFuse CONTROLLER			
eFuse Controller Autoload error	User/Privilege	ESM => nERROR	3.1
eFuse Controller - Any bit set in the error status register	User/Privilege	ESM	1.40
eFuse Controller self-test error	User/Privilege	ESM	1.41
WINDOWED WATCHDOG			
WWD Nonmaskable Interrupt exception	n/a	ESM => NMI => nERROR	2.24
ERRORS REFLECTED IN THE SYSESR REGISTER			
Power-Up Reset	n/a	Reset	n/a
Oscillator fail / PLL slip ⁽²⁾	n/a	Reset	n/a
Watchdog exception	n/a	Reset	n/a
CPU Reset (driven by the CPU STC)	n/a	Reset	n/a
Software Reset	n/a	Reset	n/a
External Reset	n/a	Reset	n/a

(2) Oscillator fail/PLL slip can be configured in the system register (SYS.PLLCTL1) to generate a reset.

6.20 Digital Windowed Watchdog

This device includes a digital windowed watchdog (DWWD) module that protects against runaway code execution.

The DWWD module allows the application to configure the time window within which the DWWD module expects the application to service the watchdog. A watchdog violation occurs if the application services the watchdog outside of this window, or fails to service the watchdog at all. The application can choose to generate a system reset or a nonmaskable interrupt to the CPU in case of a watchdog violation.

The watchdog is disabled by default and must be enabled by the application. Once enabled, the watchdog can only be disabled upon a system reset.

6.21 Debug Subsystem

6.21.1 Block Diagram

The device contains an ICEPICK module to allow JTAG access to the scan chains.

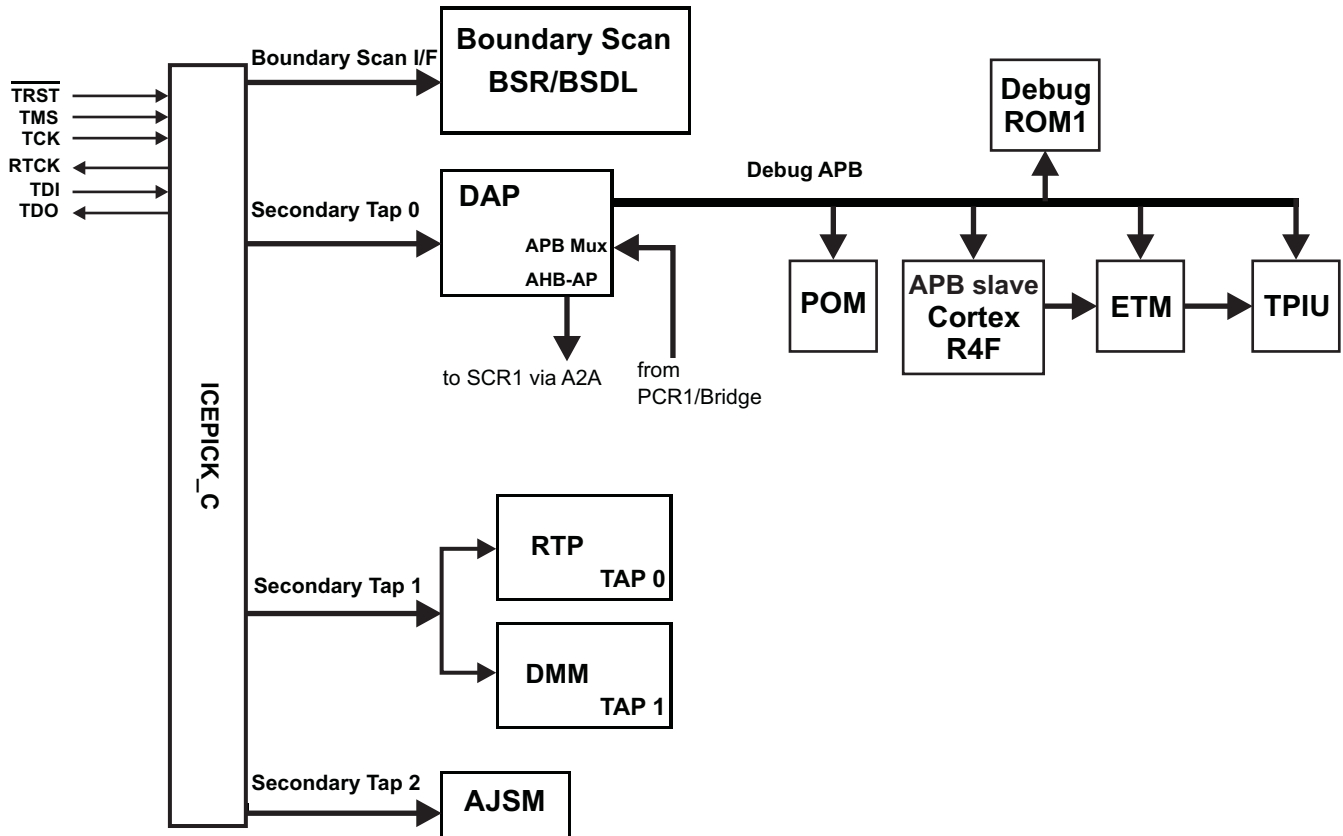

Figure 6-19. Debug Subsystem Block Diagram

NOTE

The ETM, RTP and DMM exist in silicon, but are not supported in the PGE package.

6.21.2 Debug Components Memory Map

Table 6-37. Debug Components Memory Map

MODULE NAME	FRAME CHIP SELECT	FRAME ADDRESS RANGE		FRAME SIZE	ACTUAL SIZE	RESPONSE FOR ACCESS TO UNIMPLEMENTED LOCATIONS IN FRAME
		START	END			
CoreSight Debug ROM	CSCS0	0xFFA00000	0xFFA00FFF	4KB	4KB	Reads: 0, writes: no effect
Cortex-R4F Debug	CSCS1	0xFFA01000	0xFFA01FFF	4KB	4KB	Reads: 0, writes: no effect
ETM-R4	CSCS2	0xFFA02000	0xFFA02FFF	4KB	4KB	Reads: 0, writes: no effect
CoreSight TPIU	CSCS3	0xFFA03000	0xFFA03FFF	4KB	4KB	Reads: 0, writes: no effect

6.21.3 JTAG Identification Code

The JTAG ID code for this device is the same as the device ICEPick Identification Code.

Table 6-38. JTAG ID Code

SILICON REVISION	ID
Rev A	0x0B8A002F
Rev B	0x2B8A002F
Rev C	0x3B8A002F
Rev D	0x4B8A002F

6.21.4 Debug ROM

The Debug ROM stores the location of the components on the Debug APB bus:

Table 6-39. Debug ROM table

ADDRESS	DESCRIPTION	VALUE
0x000	pointer to Cortex-R4F	0x00001003
0x001	ETM-R4	0x00002003
0x002	TPIU	0x00003003
0x003	POM	0x00004003
0x004	end of table	0x00000000

6.21.5 JTAG Scan Interface Timings

Table 6-40. JTAG Scan Interface Timing⁽¹⁾

NO.	PARAMETER	MIN	MAX	UNIT
	fTCK TCK frequency (at HCLKmax)		12	MHz
	fRTCK RTCK frequency (at TCKmax and HCLKmax)	10		MHz
1	td(TCK -RTCK) Delay time, TCK to RTCK		24	ns
2	tsu(TDI/TMS - RTCKr) Setup time, TDI, TMS before RTCK rise (RTCKr)	26		ns
3	th(RTCKr -TDI/TMS) Hold time, TDI, TMS after RTCKr	0		ns
4	th(RTCKr -TDO) Hold time, TDO after RTCKf	0		ns
5	td(TCKf -TDO) Delay time, TDO valid after RTCK fall (RTCKf)		12	ns

(1) Timings for TDO are specified for a maximum of 50pF load on TDO

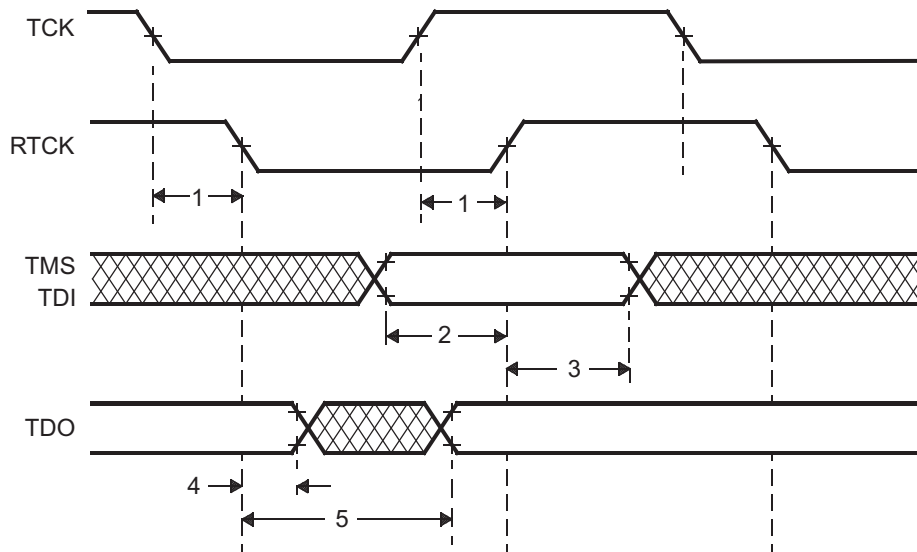

Figure 6-20. JTAG Timing

6.21.6 Advanced JTAG Security Module

This device includes an Advanced JTAG Security Module (AJSM) which provides maximum security to the memory content of the device by letting users secure the device after programming.

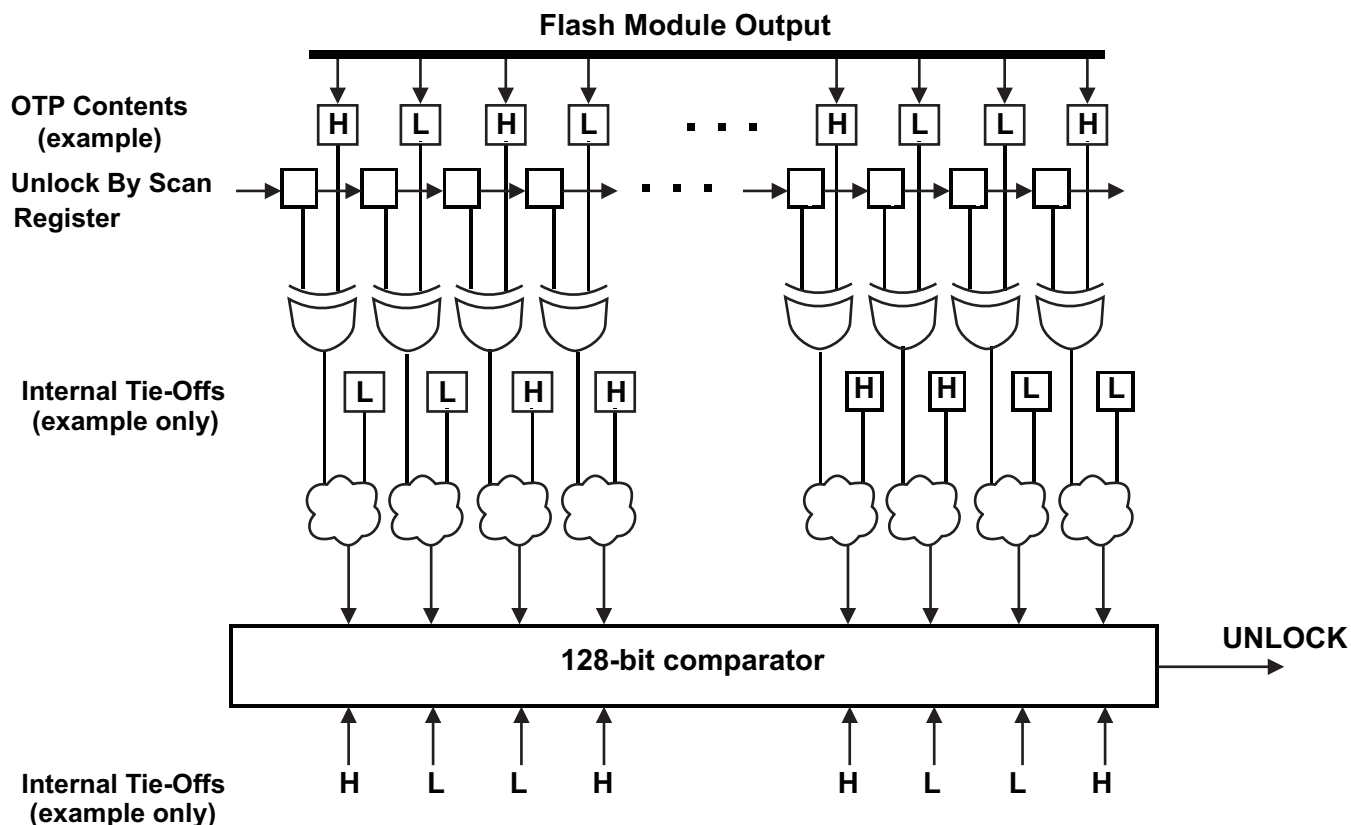

Figure 6-21. AJSM Unlock

The device is unsecure by default by virtue of a 128-bit visible unlock code programmed in the OTP address 0xF0000000. The OTP contents are XOR-ed with the "Unlock By Scan" register contents. The outputs of these XOR gates are again combined with a set of secret internal tie-offs. The output of this combinational logic is compared against a secret hard-wired 128-bit value. A match results in the UNLOCK signal being asserted, so that the device is now unsecure.

A user can secure the device by changing at least one bit in the visible unlock code from 1 to 0. Changing a 0 to 1 is not possible because the visible unlock code is stored in the One Time Programmable (OTP) flash region. Also, changing all the 128 bits to zeros is not a valid condition and will permanently secure the device.

Once secured, a user can unsecure the device by scanning an appropriate value into the "Unlock By Scan" register of the AJSM module. The value to be scanned is such that the XOR of the OTP contents and the Unlock-By-Scan register contents results in the original visible unlock code.

The Unlock-By-Scan register is reset only upon asserting power-on reset (nPORRST).

A secure device only permits JTAG accesses to the AJSM scan chain via the Secondary Tap # 2 of the ICEPick module. All other secondary taps, test taps and the boundary scan interface are not accessible in this state.

6.21.7 Embedded Trace Macrocell (ETM-R4)

The device contains a ETM-R4 module with a 32-bit internal data port. The ETM-R4 module is connected to a TPIU with a 32-bit data bus; the TPIU provides a 35-bit (32-bit data, 3-bit control) external interface for trace. The ETM-R4 is CoreSight compliant and follows the ETM v3 specification; for more details see ARM CoreSight ETM-R4 TRM specification.

6.21.7.1 ETM TRACECLKIN Selection

The ETM clock source can be selected as either VCLK or the external ETMTRACECLKIN pin. The selection is done by the EXTCTLOUT[1:0] control bits of the TPIU; the default is '00'. The address of this register is TPIU base address + 0x404.

Before you begin accessing TPIU registers, TPIU should be unlocked via coresight key and 1 or 2 should be written to this register.

Table 6-41. TPIU / TRACECLKIN Selection

EXTCTLOUT[1:0]	TPIU/TRACECLKIN
00	tied-zero
01	VCLK
10	ETMTRACECLKIN
11	tied-zero

6.21.7.2 Timing Specifications

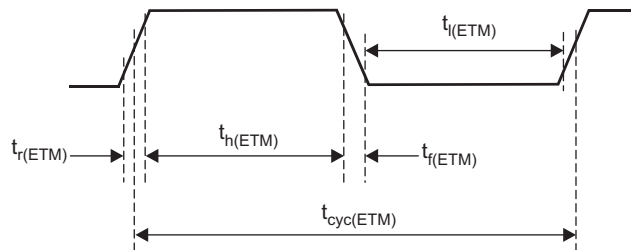

Figure 6-22. ETMTRACECLKOUT Timing

Table 6-42. ETMTRACECLK Timing

PARAMETER		MIN	MAX	UNIT
$t_{cyc}(ETM)$	Clock period	$t_{(HCLK)} * 4$		ns
$t_l(ETM)$	Low pulse width	20		ns
$t_h(ETM)$	High pulse width	20		ns
$t_r(ETM)$	Clock and data rise time		3	ns
$t_f(ETM)$	Clock and data fall time		3	ns

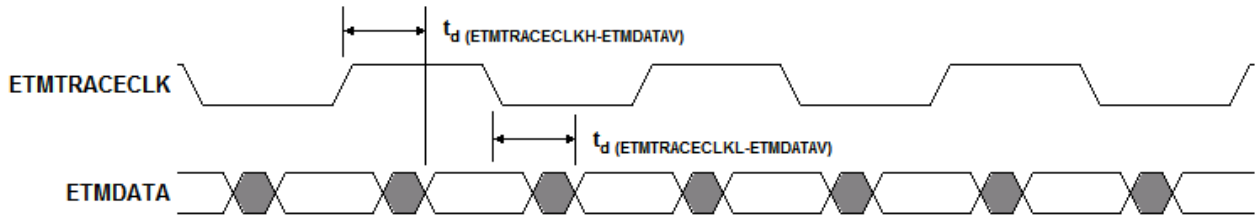

Figure 6-23. ETMDATA Timing

Table 6-43. ETMDATA Timing

PARAMETER		MIN	MAX	UNIT
$t_{d(ETMTRACECLKH-ETMDATAV)}$	Delay time, ETM trace clock high to ETM data valid	1.5	7	ns
$t_{d(ETMTRACECLKL-ETMDATAV)}$	Delay time, ETM trace clock low to ETM data valid	1.5	7	ns

NOTE

The ETMTRACECLK and ETMDATA timing is based on a 15-pF load and for ambient temperature lower than 85°C.

6.21.8 RAM Trace Port (RTP)

The RTP provides the ability to datalog the RAM contents of the RM4x devices or accesses to peripherals without program intrusion. It can trace all data write or read accesses to internal RAM. In addition, it provides the capability to directly transfer data to a FIFO to support a CPU-controlled transmission of the data. The trace data is transmitted over a dedicated external interface.

6.21.8.1 Features

The RTP offers the following features:

- Two modes of operation - Trace Mode and Direct Data Mode
 - Trace Mode
 - Nonintrusive data trace on write or read operation
 - Visibility of RAM content at any time on external capture hardware
 - Trace of peripheral accesses
 - 2 configurable trace regions for each RAM module to limit amount of data to be traced
 - FIFO to store data and address of data of multiple read/write operations
 - Trace of CPU and/or DMA accesses with indication of the master in the transmitted data packet
 - Direct Data Mode
 - Directly write data with the CPU or trace read operations to a FIFO, without transmitting header and address information
- Dedicated synchronous interface to transmit data to external devices
- Free-running clock generation or clock stop mode between transmissions
- Up to 100 Mbps/pin transfer rate for transmitting data
- Pins not used in functional mode can be used as GIOs

6.21.8.2 Timing Specifications

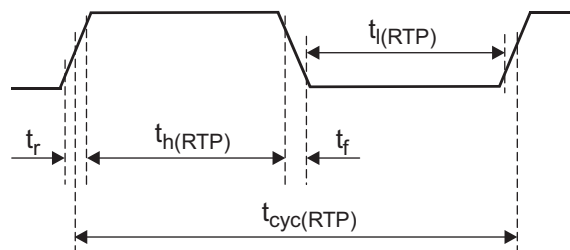

Figure 6-24. RTPCLK Timing

Table 6-44. RTPCLK Timing

PARAMETER		MIN	MAX	UNIT
$t_{cyc(RTP)}$	Clock period, prescaled from HCLK; must not be faster than HCLK / 2	11 (= 90 MHz)		ns
$t_{h(RTP)}$	High pulse width	$((t_{cyc(RTP)})/2) - ((t_r+t_f)/2)$		ns
$t_{l(RTP)}$	Low pulse width	$((t_{cyc(RTP)})/2) - ((t_r+t_f)/2)$		ns

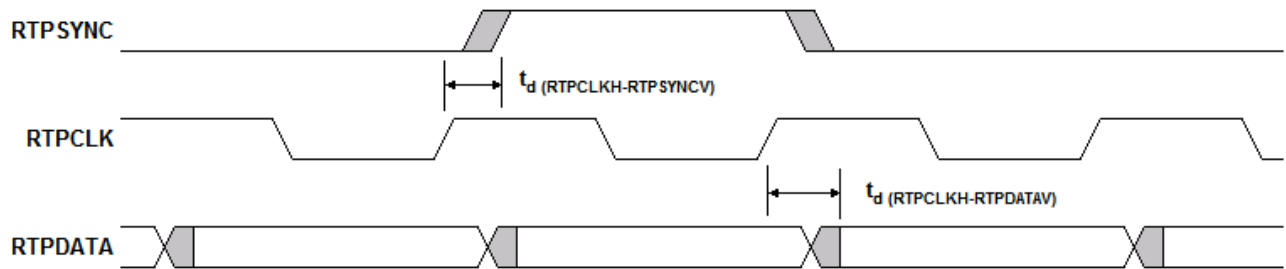

Figure 6-25. RTPDATA Timing

Table 6-45. RTPDATA Timing

PARAMETER	MIN	MAX	UNIT
$t_d(RTPCLKH-RTPSYNCV)$	-5	4	ns
$t_d(RTPCLKH-RTPDATAV)$	-5	4	ns

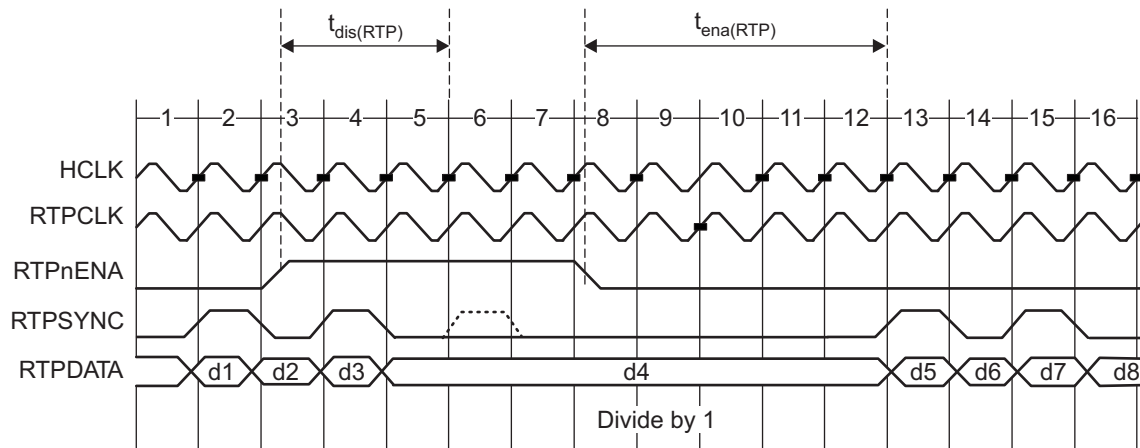

Figure 6-26. RTPnENA Timing

Table 6-46. RTPnENA Timing

PARAMETER	MIN	MAX	UNIT
$t_{dis}(RTP)$	time RTPnENA must go high before what would be the next RTPSYNC, to ensure delaying the next packet		ns
$t_{ena}(RTP)$	time after RTPnENA goes low before a packet that has been halted, resumes		ns

6.21.9 Data Modification Module (DMM)

The Data Modification Module (DMM) provides the capability to modify data in the entire 4-GB address space of the RM4x devices from an external peripheral, with minimal interruption of the application.

6.21.9.1 Features

The DMM module has the following features:

- Acts as a bus master, thus enabling direct writes to the 4-GB address space without CPU intervention
- Writes to memory locations specified in the received packet (leverages packets defined by trace mode of the RAM trace port (RTP) module)
- Writes received data to consecutive addresses, which are specified by the DMM module (leverages packets defined by direct data mode of RTP module)
- Configurable port width (1, 2, 4, 8, 16 pins)
- Up to 100 Mbit/s pin data rate
- Unused pins configurable as GPIO pins

6.21.9.2 Timing Specifications

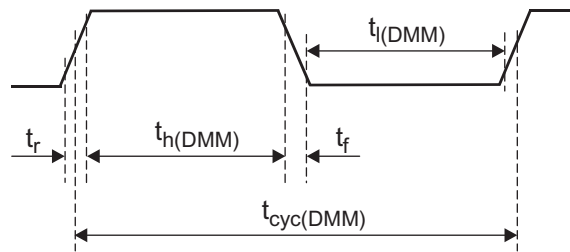

Figure 6-27. DMMCLK Timing

Table 6-47. Timing Requirements for DMMCLK

		MIN	MAX	UNIT
$t_{cyc}(DMM)$	Cycle time, DMMCLK period	$t_{c(HCLK)} * 2$		ns
$t_h(DMM)$	Pulse duration, DMMCLK high	$((t_{cyc}(DMM))/2) - ((t_r+t_l)/2)$		ns
$t_l(DMM)$	Pulse duration, DMMCLK low	$((t_{cyc}(DMM))/2) - ((t_r+t_l)/2)$		ns

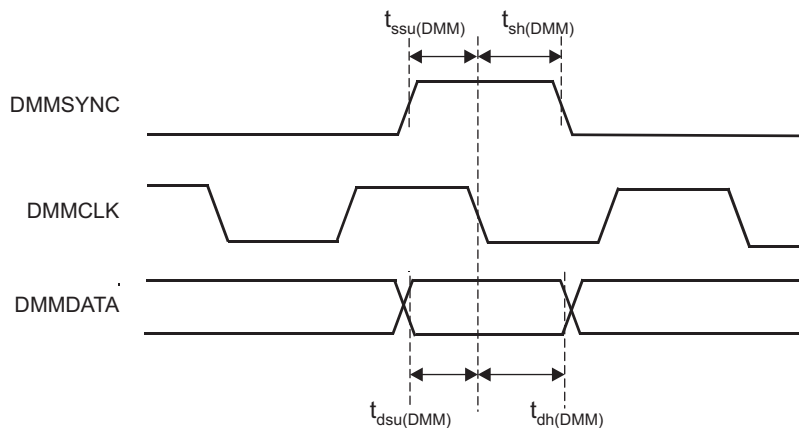

Figure 6-28. DMMDATA Timing

Table 6-48. Timing Requirements for DMMDATA

		MIN	MAX	UNIT
$t_{ssu(DMM)}$	SYNC active to clk falling edge setup time	2		ns
$t_{sh(DMM)}$	clk falling edge to SYNC inactive hold time	3		ns
$t_{dsu(DMM)}$	DATA to clk falling edge setup time	2		ns
$t_{dh(DMM)}$	clk falling edge to DATA hold time	3		ns

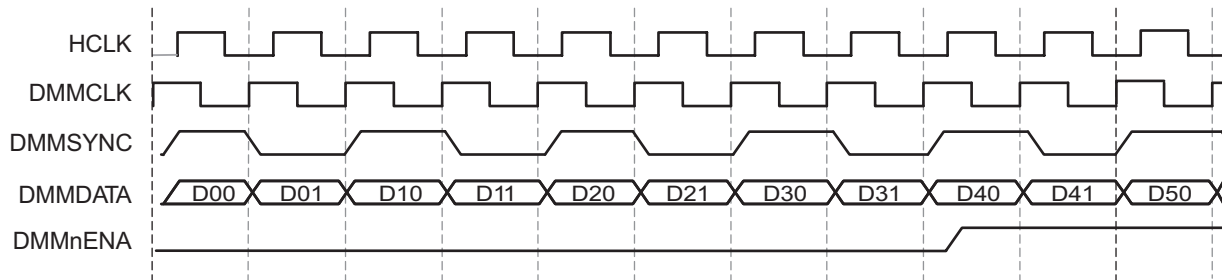

Figure 6-29. DMMnENA Timing

Figure 6-29 shows a case with 1 DMM packet per 2 DMMCLK cycles (Mode = Direct Data Mode, data width = 8, port width = 4) where none of the packets received by the DMM are sent out, leading to filling up of the internal buffers. The DMMnENA signal is shown asserted, after the first two packets have been received and synchronized to the HCLK domain. Here, the DMM has the capacity to accept packets D4x, D5x, D6x, D7x. Packet D8 would result in an overflow. Once DMMnENA is asserted, the DMM expects to stop receiving packets after 4 HCLK cycles; once DMMnENA is deasserted, the DMM can handle packets immediately (after 0 HCLK cycles).

6.21.10 Boundary Scan Chain

The device supports IEEE1149.1-compliant boundary scan for testing pin-to-pin compatibility. The boundary scan chain is connected to the Boundary Scan Interface of the ICEPICK module.

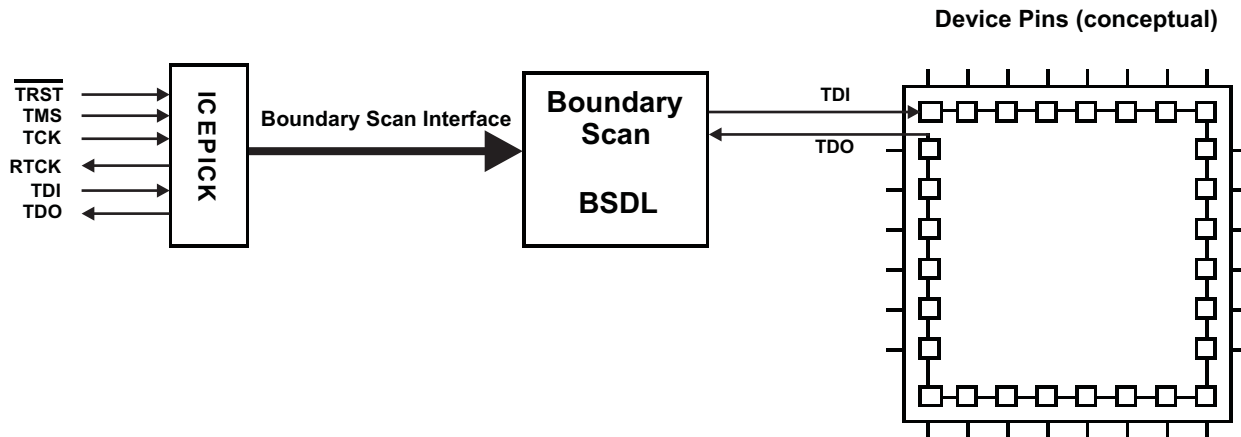

Figure 6-30. Boundary Scan Implementation (Conceptual Diagram)

Data is serially shifted into all boundary-scan buffers via TDI, and out via TDO.

7 Peripheral Information and Electrical Specifications

7.1 Peripheral Legend

Table 7-1. Peripheral Legend

ABBREVIATION	FULL NAME
MibADC	Analog To Digital Converter
CCM-R4F	CPU Compare Module - CortexR4F
CRC	Cyclic Redundancy Check
DCAN	Controller Area Network
DCC	Dual Clock Comparator
DMA	Direct Memory Access
DMM	Data Modification Module
EMIF	External Memory Interface
ESM	Error Signaling Module
ETM-R4F	Embedded Trace Macrocell - CortexR4F
GPIO	General-Purpose Input/Output
HTU	High End Timer Transfer Unit
I2C	Inter-Integrated Circuit
LIN	Local Interconnect Network
MIBSPI	Multibuffer Serial Peripheral Interface
N2HET	Platform High-End Timer
POM	Parameter Overlay Module
RTI	Real-Time Interrupt Module
RTP	RAM Trace Port
SPI	Serial Peripheral Interface
USB	Universal Serial Bus
VIM	Vectored Interrupt Manager

7.2 Multibuffered 12-Bit Analog-to-Digital Converter

The multibuffered A-to-D converter (MibADC) has a separate power bus for its analog circuitry that enhances the A-to-D performance by preventing digital switching noise on the logic circuitry which could be present on V_{SS} and V_{CC} from coupling into the A-to-D analog stage. All A-to-D specifications are given with respect to AD_{REFLO} unless otherwise noted.

Table 7-2. MibADC Overview

DESCRIPTION	VALUE
Resolution	12 bits
Monotonic	Assured
Output conversion code	00h to FFFh [00 for $V_{AI} \leq AD_{REFLO}$; FFF for $V_{AI} \geq AD_{REFHI}$]

7.2.1 Features

- 10-/12-bit resolution
- AD_{REFHI} and AD_{REFLO} pins (high and low reference voltages)
- Total Sample/Hold/Convert time: 600 ns Typical Minimum at 30 MHz ADCLK
- One memory region per conversion group is available (event, group 1, group 2)
- Allocation of channels to conversion groups is completely programmable
- Memory regions are serviced either by interrupt or by DMA
- Programmable interrupt threshold counter is available for each group
- Programmable magnitude threshold interrupt for each group for any one channel
- Option to read either 8-bit, 10-bit or 12-bit values from memory regions
- Single or continuous conversion modes
- Embedded self-test
- Embedded calibration logic
- Enhanced power-down mode
 - Optional feature to automatically power down ADC core when no conversion is in progress
- External event pin (ADEV_T) programmable as general-purpose I/O

7.2.2 Event Trigger Options

The ADC module supports 3 conversion groups: Event Group, Group1 and Group2. Each of these 3 groups can be configured to be hardware event-triggered. In that case, the application can select from among 8 event sources to be the trigger for a group's conversions.

7.2.2.1 Default MIBADC1 Event Trigger Hookup

Table 7-3. MIBADC1 Event Trigger Hookup

Event #	Source Select Bits For G1, G2 Or Event (G1SRC[2:0], G2SRC[2:0] or EVSRC[2:0])	Trigger
1	000	ADEV _T
2	001	N2HET1[8]
3	010	N2HET1[10]
4	011	RTI compare 0 interrupt
5	100	N2HET1[12]
6	101	N2HET1[14]
7	110	GIOB[0]
8	111	GIOB[1]

NOTE

For ADEV_T, N2HET1 and GIOB trigger sources, the connection to the MibADC1 module trigger input is made from the output side of the input buffer. This way, a trigger condition can be generated either by configuring the function as output onto the pad (via the mux control), or by driving the function from an external trigger source as input. If the mux control module is used to select different functionality instead of the ADEV_T, N2HET1[x] or GIOB[x] signals, then care must be taken to disable these signals from triggering conversions; there is no multiplexing on the input connections.

NOTE

For the RTI compare 0 interrupt source, the connection is made directly from the output of the RTI module. That is, the interrupt condition can be used as a trigger source even if the actual interrupt is not signaled to the CPU.

7.2.2.2 Alternate MIBADC1 Event Trigger Hookup

Table 7-4. Alternate MIBADC1 Event Trigger Hookup

EVENT #	SOURCE SELECT BITS FOR G1, G2 OR EVENT (G1SRC[2:0], G2SRC[2:0] or EVSRC[2:0])	TRIGGER
1	000	ADEVT
2	001	N2HET2[5]
3	010	N2HET1[27]
4	011	RTI compare 0 interrupt
5	100	N2HET1[17]
6	101	N2HET1[19]
7	110	N2HET1[11]
8	111	N2HET2[13]

The selection between the default MIBADC1 event trigger hook-up versus the alternate event trigger hook-up is done by multiplexing control module register 30 bits 0 and 1.

If 30[0] = 1, then the default MibADC1 event trigger hook-up is used.

If 30[0] = 0 and 30[1] = 1, then the alternate MibADC1 event trigger hook-up is used.

NOTE

For ADEVT trigger source, the connection to the MibADC1 module trigger input is made from the output side of the input buffer. This way, a trigger condition can be generated either by configuring ADEVT as an output function on to the pad (via the mux control), or by driving the ADEVT signal from an external trigger source as input. If the mux control module is used to select different functionality instead of the ADEVT signal, then care must be taken to disable ADEVT from triggering conversions; there is no multiplexing on the input connection.

NOTE

For N2HETx trigger sources, the connection to the MibADC1 module trigger input is made from the input side of the output buffer (at the N2HETx module boundary). This way, a trigger condition can be generated even if the N2HETx signal is not selected to be output on the pad.

NOTE

For the RTI compare 0 interrupt source, the connection is made directly from the output of the RTI module. That is, the interrupt condition can be used as a trigger source even if the actual interrupt is not signaled to the CPU.

7.2.2.3 Default MIBADC2 Event Trigger Hookup

Table 7-5. MIBADC2 Event Trigger Hookup

EVENT #	SOURCE SELECT BITS FOR G1, G2 OR EVENT (G1SRC[2:0], G2SRC[2:0] or EVSRC[2:0])	TRIGGER
1	000	AD2EVT
2	001	N2HET1[8]
3	010	N2HET1[10]
4	011	RTI compare 0
5	100	N2HET1[12]
6	101	N2HET1[14]
7	110	GIOB[0]
8	111	GIOB[1]

NOTE

For AD2EVT, N2HET1 and GIOB trigger sources, the connection to the MibADC2 module trigger input is made from the output side of the input buffer. This way, a trigger condition can be generated either by configuring the function as output onto the pad (via the mux control), or by driving the function from an external trigger source as input. If the mux control module is used to select different functionality instead of the AD2EVT, N2HET1[x] or GIOB[x] signals, then care must be taken to disable these signals from triggering conversions; there is no multiplexing on the input connections.

NOTE

For the RTI compare 0 interrupt source, the connection is made directly from the output of the RTI module. That is, the interrupt condition can be used as a trigger source even if the actual interrupt is not signaled to the CPU.

7.2.2.4 Alternate MIBADC2 Event Trigger Hookup

Table 7-6. Alternate MIBADC2 Event Trigger Hookup

EVENT #	SOURCE SELECT BITS FOR G1, G2 OR EVENT (G1SRC[2:0], G2SRC[2:0] or EVSRC[2:0])	TRIGGER
1	000	AD2EVT
2	001	N2HET2[5]
3	010	N2HET1[27]
4	011	RTI compare 0
5	100	N2HET1[17]
6	101	N2HET1[19]
7	110	N2HET1[11]
8	111	N2HET2[13]

The selection between the default MIBADC2 event trigger hook-up versus the alternate event trigger hook-up is done by multiplexing control module register 30 bits 0 and 1.

If 30[0] = 1, then the default MibADC2 event trigger hook-up is used.

If 30[0] = 0 and 30[1] = 1, then the alternate MibADC2 event trigger hook-up is used.

NOTE

For AD2EVT trigger source, the connection to the MibADC2 module trigger input is made from the output side of the input buffer. This way, a trigger condition can be generated either by configuring AD2EVT as an output function on to the pad (via the mux control), or by driving the AD2EVT signal from an external trigger source as input. If the mux control module is used to select different functionality instead of the AD2EVT signal, then care must be taken to disable AD2EVT from triggering conversions; there is no multiplexing on the input connections.

NOTE

For N2HETx trigger sources, the connection to the MibADC2 module trigger input is made from the input side of the output buffer (at the N2HETx module boundary). This way, a trigger condition can be generated even if the N2HETx signal is not selected to be output on the pad.

NOTE

For the RTI compare 0 interrupt source, the connection is made directly from the output of the RTI module. That is, the interrupt condition can be used as a trigger source even if the actual interrupt is not signaled to the CPU.

7.2.3 ADC Electrical and Timing Specifications

Table 7-7. MibADC Recommended Operating Conditions

PARAMETER		MIN	MAX	UNIT
AD _{REFHI}	A-to-D high-voltage reference source	AD _{REFLO}	V _{CCAD} ⁽¹⁾	V
AD _{REFLO}	A-to-D low-voltage reference source	V _{SSAD} ⁽¹⁾	AD _{REFHI}	V
V _{AI}	Analog input voltage	AD _{REFLO}	AD _{REFHI}	V
I _{AIK}	Analog input clamp current ⁽²⁾ (V _{AI} < V _{SSAD} – 0.3 or V _{AI} > V _{CCAD} + 0.3)	- 2	2	mA

(1) For V_{CCAD} and V_{SSAD} recommended operating conditions, see Section 5.4.

(2) Input currents into any ADC input channel outside the specified limits could affect conversion results of other channels.

Table 7-8. MibADC Electrical Characteristics Over Full Ranges of Recommended Operating Conditions

PARAMETER		DESCRIPTION/CONDITIONS		MIN	MAX	UNIT
R _{mux}	Analog input mux on-resistance	See Figure 7-1			250	Ω
R _{samp}	ADC sample switch on-resistance	See Figure 7-1			250	Ω
C _{mux}	Input mux capacitance	See Figure 7-1			16	pF
C _{samp}	ADC sample capacitance	See Figure 7-1			13	pF
I _{AiL}	Analog off-state input leakage current	V _{CCAD} = 3.6 V maximum	V _{SSAD} ≤ V _{IN} < V _{SSAD} + 100 mV	-300	200	nA
			V _{SSAD} + 100 mV ≤ V _{IN} ≤ V _{CCAD} - 200 mV	-200	200	
			V _{CCAD} - 200 mV < V _{IN} ≤ V _{CCAD}	-200	500	
I _{AiL}	Analog off-state input leakage current	V _{CCAD} = 5.5 V maximum	V _{SSAD} ≤ V _{IN} < V _{SSAD} + 300 mV	-1000	250	nA
			V _{SSAD} + 300 mV ≤ V _{IN} ≤ V _{CCAD} - 300 mV	-250	250	
			V _{CCAD} - 300 mV < V _{IN} ≤ V _{CCAD}	-250	1000	
I _{AOSB1} ⁽¹⁾	ADC1 Analog on-state input bias current	V _{CCAD} = 3.6 V maximum	V _{SSAD} ≤ V _{IN} < V _{SSAD} + 100 mV	-8	2	μA
			V _{SSAD} + 100 mV < V _{IN} < V _{CCAD} - 200 mV	-4	2	
			V _{CCAD} - 200 mV < V _{IN} < V _{CCAD}	-4	12	
I _{AOSB2} ⁽¹⁾	ADC2 Analog on-state input bias current	V _{CCAD} = 3.6 V maximum	V _{SSAD} ≤ V _{IN} < V _{SSAD} + 100 mV	-7	2	μA
			V _{SSAD} + 100 mV ≤ V _{IN} ≤ V _{CCAD} - 200 mV	-4	2	
			V _{CCAD} - 200 mV < V _{IN} ≤ V _{CCAD}	-4	10	
I _{AOSB1} ⁽¹⁾	ADC1 Analog on-state input bias current	V _{CCAD} = 5.5 V maximum	V _{SSAD} ≤ V _{IN} < V _{SSAD} + 300 mV	-10	3	μA
			V _{SSAD} + 300 mV ≤ V _{IN} ≤ V _{CCAD} - 300 mV	-5	3	
			V _{CCAD} - 300 mV < V _{IN} ≤ V _{CCAD}	-5	14	
I _{AOSB2} ⁽¹⁾	ADC2 Analog on-state input bias current	V _{CCAD} = 5.5 V maximum	V _{SSAD} ≤ V _{IN} < V _{SSAD} + 300 mV	-8	3	μA
			V _{SSAD} + 300 mV ≤ V _{IN} ≤ V _{CCAD} - 300 mV	-5	3	
			V _{CCAD} - 300 mV < V _{IN} ≤ V _{CCAD}	-5	12	
I _{ADREFHI}	AD _{REFHI} input current	AD _{REFHI} = V _{CCAD} , AD _{REFLO} = V _{SSAD}			3	mA
I _{CCAD}	Static supply current	Normal operating mode			15	mA
		ADC core in power down mode			5	μA

(1) If a shared channel is being converted by both ADC converters at the same time, the on-state leakage is equal to I_{AOSL1} + I_{AOSL2}

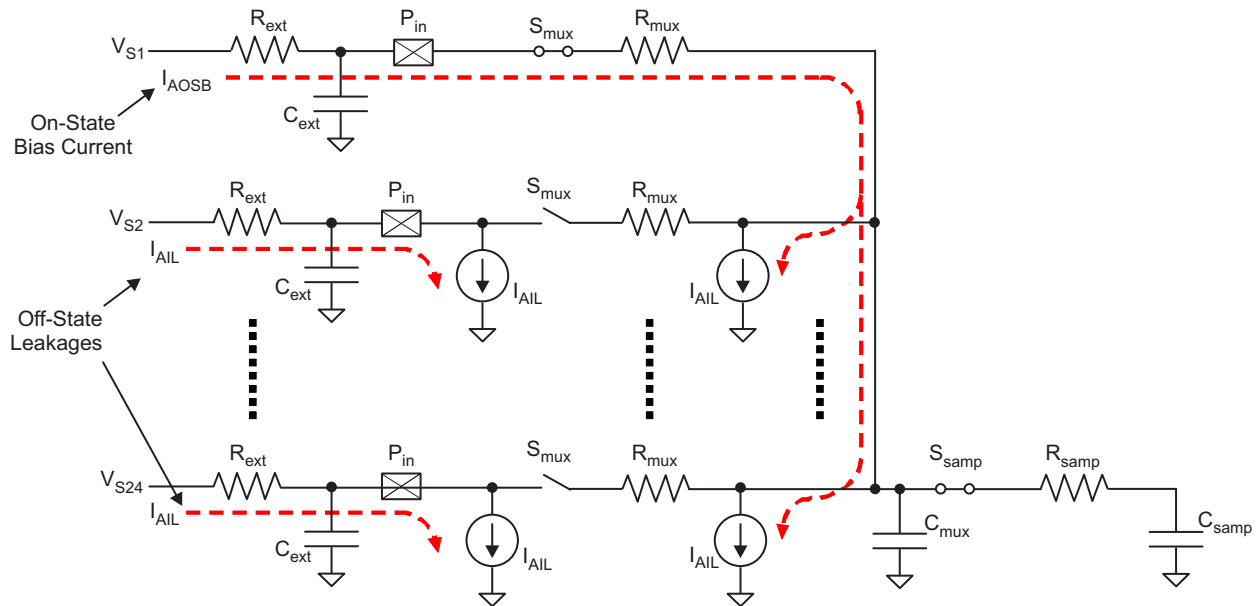

Figure 7-1. MibADC Input Equivalent Circuit

Table 7-9. MibADC Timing Specifications

PARAMETER		MIN	NOM	MAX	UNIT
$t_{c(ADCLK)}^{(1)}$	Cycle time, MibADC clock	0.033			μs
$t_{d(SH)}^{(2)}$	Delay time, sample and hold time	0.2			μs
$t_{d(PU-ADV)}$	Delay time from ADC power on until first input can be sampled	1			μs
12-BIT MODE					
$t_{d(c)}$	Delay time, conversion time	0.4			μs
$t_{d(SHC)}^{(3)}$	Delay time, total sample/hold and conversion time	0.6			μs
10-BIT MODE					
$t_{d(c)}$	Delay time, conversion time	0.33			μs
$t_{d(SHC)}^{(3)}$	Delay time, total sample/hold and conversion time	0.53			μs

- (1) The MibADC clock is the ADCLK, generated by dividing down the VCLK by a prescale factor defined by the ADCLOCKCR register bits 4:0.
- (2) The sample and hold time for the ADC conversions is defined by the ADCLK frequency and the AD<GP>SAMP register for each conversion group. The sample time needs to be determined by accounting for the external impedance connected to the input channel as well as the ADC's internal impedance.
- (3) This is the minimum sample/hold and conversion time that can be achieved. These parameters are dependent on many factors, for example, the prescale settings.

Table 7-10. MibADC Operating Characteristics Over Full Ranges of Recommended Operating Conditions

PARAMETER		DESCRIPTION/CONDITIONS	MIN	NOM	MAX	UNIT
CR	Conversion range over which specified accuracy is maintained	$AD_{REFHI} - AD_{REFLO}$	3		5.5	V
Z _{SET}	Zero Scale Offset	Difference between the first ideal transition (from code 000h to 001h) and the actual transition	10-bit mode		1	LSB ⁽¹⁾
			12-bit mode		2	LSB ⁽²⁾
F _{SET}	Full Scale Offset	Difference between the range of the measured code transitions (from first to last) and the range of the ideal code transitions	10-bit mode		2	LSB
			12-bit mode		3	LSB
E _{DNL}	Differential nonlinearity error	Difference between the actual step width and the ideal value. (See Figure 76)	10-bit mode		± 1.5	LSB
			12-bit mode		± 2	LSB
E _{INL}	Integral nonlinearity error	Maximum deviation from the best straight line through the MibADC. MibADC transfer characteristics, excluding the quantization error.	10-bit mode		± 2	LSB
			12-bit mode		± 2	LSB
E _{TOT}	Total unadjusted error	Maximum value of the difference between an analog value and the ideal midstep value.	10-bit mode		± 2	LSB
			12-bit mode		± 4	LSB

(1) 1 LSB = $(AD_{REFHI} - AD_{REFLO}) / 2^{10}$ for 10-bit mode
 (2) 1 LSB = $(AD_{REFHI} - AD_{REFLO}) / 2^{12}$ for 12-bit mode

7.2.4 Performance (Accuracy) Specifications

7.2.4.1 MibADC Nonlinearity Errors

The differential nonlinearity error shown in Figure 7-2 (sometimes referred to as differential linearity) is the difference between an actual step width and the ideal value of 1 LSB.

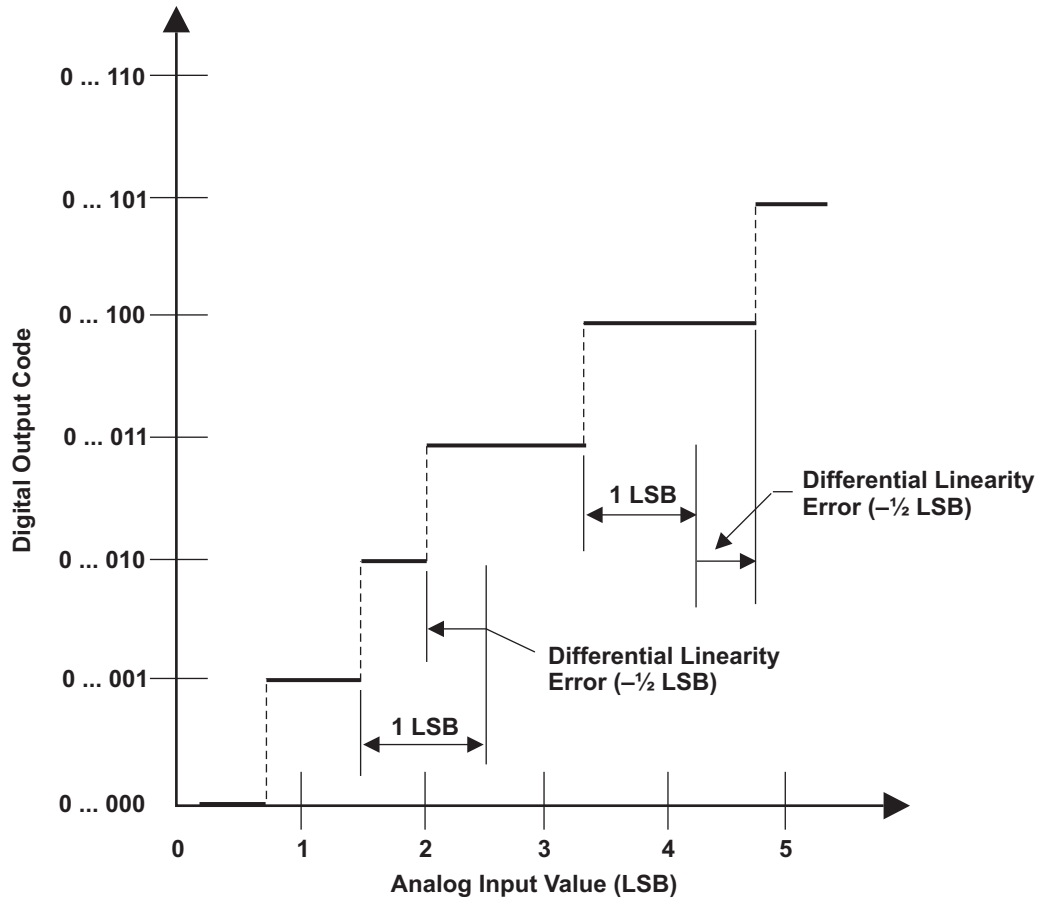

NOTE A: $1 \text{ LSB} = (AD_{\text{REFHI}} - AD_{\text{REFLO}}) / 2^{12}$

Figure 7-2. Differential Nonlinearity (DNL) Error

The integral nonlinearity error shown in Figure 7-3 (sometimes referred to as linearity error) is the deviation of the values on the actual transfer function from a straight line.

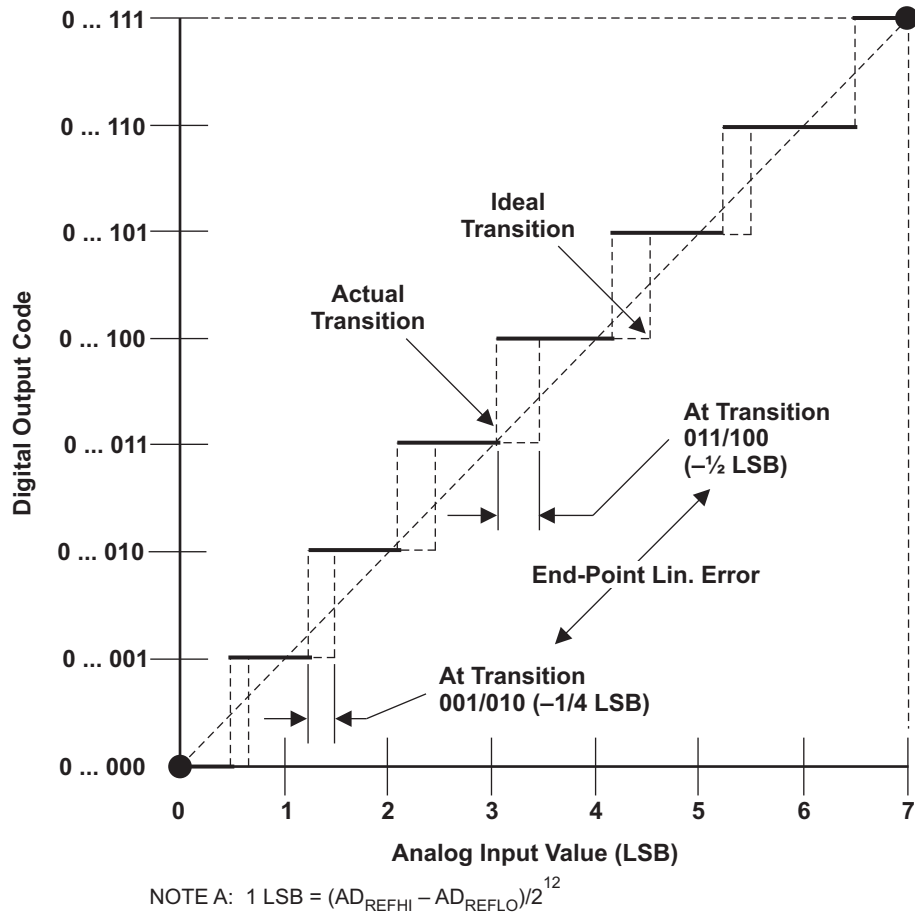

Figure 7-3. Integral Nonlinearity (INL) Error

7.2.4.2 MibADC Total Error

The absolute accuracy or total error of an MibADC as shown in Figure 7-4 is the maximum value of the difference between an analog value and the ideal midstep value.

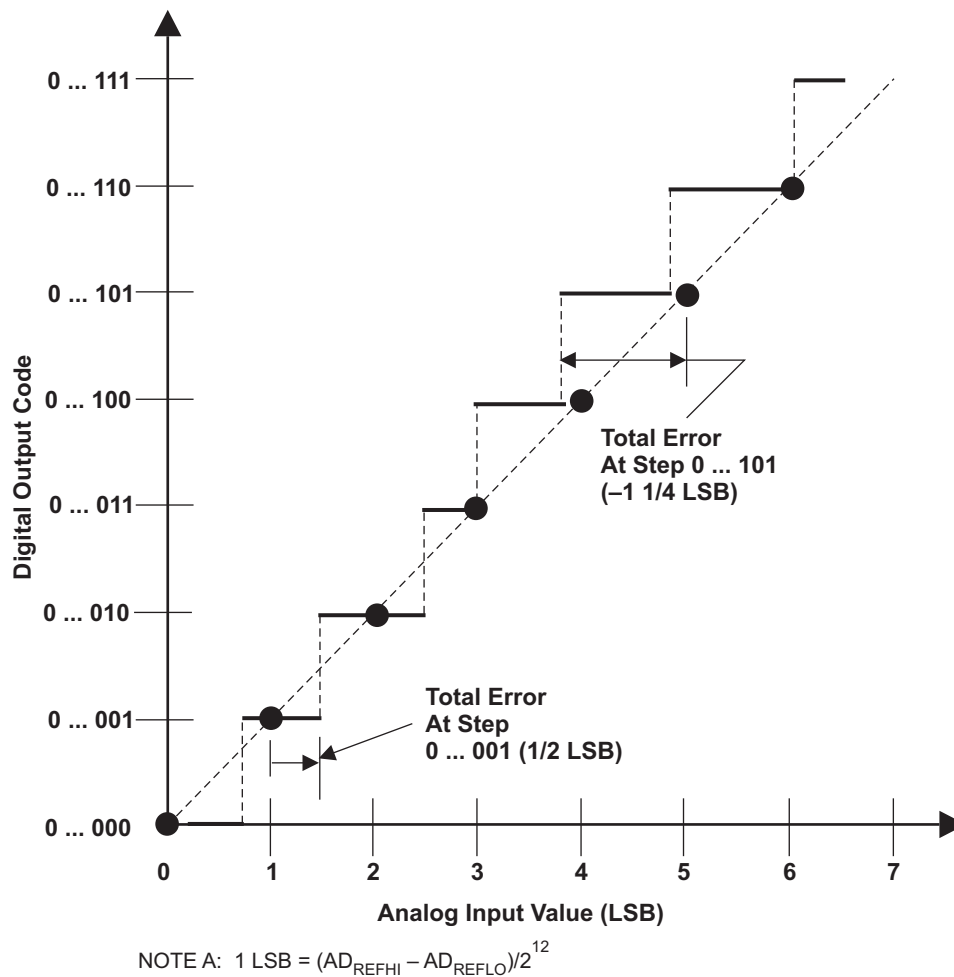

Figure 7-4. Absolute Accuracy (Total) Error

7.3 General-Purpose Input/Output

The GPIO module on this device supports two ports, GIOA and GIOB. The I/O pins are bidirectional and bit-programmable. Both GIOA and GIOB support external interrupt capability.

7.3.1 Features

The GPIO module has the following features:

- Each IO pin can be configured as:
 - Input
 - Output
 - Open Drain
- The interrupts have the following characteristics:
 - Programmable interrupt detection either on both edges or on a single edge (set in GIOINTDET)
 - Programmable edge-detection polarity, either rising or falling edge (set in GIOPOL register)
 - Individual interrupt flags (set in GIOFLG register)
 - Individual interrupt enables, set and cleared through GIOENASET and GIOENACLR registers respectively
 - Programmable interrupt priority, set through GIOLVLSET and GIOLVLCLR registers
- Internal pullup/pulldown allows unused I/O pins to be left unconnected

For information on input and output timings see [Section 5.11](#) and [Section 5.12](#)

7.4 Enhanced High-End Timer (N2HET)

The N2HET is an advanced intelligent timer that provides sophisticated timing functions for real-time applications. The timer is software-controlled, using a reduced instruction set, with a specialized timer micromachine and an attached I/O port. The N2HET can be used for pulse width modulated outputs, capture or compare inputs, or general-purpose I/O. It is especially well suited for applications requiring multiple sensor information and drive actuators with complex and accurate time pulses.

7.4.1 Features

The N2HET module has the following features:

- Programmable timer for input and output timing functions
- Reduced instruction set (30 instructions) for dedicated time and angle functions
- 160 words of instruction RAM protected by parity
- User defined number of 25-bit virtual counters for timer, event counters and angle counters
- 7-bit hardware counters for some pins allow up to 32-bit resolution in conjunction with the 25-bit virtual counters
- Up to 32 pins usable for input signal measurements or output signal generation
- Programmable suppression filter for each input pin with adjustable limiting frequency
- Low CPU overhead and interrupt load
- Efficient data transfer to or from the CPU memory with dedicated High-End-Timer Transfer Unit (HTU) or DMA
- Diagnostic capabilities with different loopback mechanisms and pin status readback functionality

7.4.2 N2HET RAM Organization

The timer RAM uses 4 RAM banks, where each bank has two port access capability. This means that one RAM address may be written while another address is read. The RAM words are 96 bits wide, which are split into three 32-bit fields (program, control, and data).

7.4.3 Input Timing Specifications

The N2HET instructions PCNT and WCAP impose some timing constraints on the input signals.

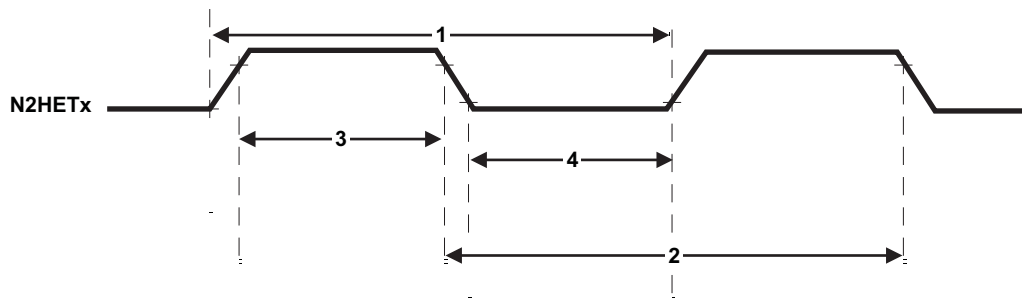

Figure 7-5. N2HET Input Capture Timings

Table 7-11. Input Timing Requirements for the N2HET Input Capture Functionality

NO.		MIN ^{(1) (2)}	MAX ^{(1) (2)}	UNIT
1	Input signal period, PCNT or WCAP for rising edge to rising edge	2 (hr) (lr) $t_{C(VCLK2)} + 2$	2^{25} (hr) (lr) $t_{C(VCLK2)} - 2$	ns
2	Input signal period, PCNT or WCAP for falling edge to falling edge	2 (hr) (lr) $t_{C(VCLK2)} + 2$	2^{25} (hr) (lr) $t_{C(VCLK2)} - 2$	ns
3	Input signal high phase, PCNT or WCAP for rising edge to falling edge	(hr) (lr) $t_{C(VCLK2)} + 2$	2^{25} (hr) (lr) $t_{C(VCLK2)} - 2$	ns
4	Input signal low phase, PCNT or WCAP for falling edge to rising edge	(hr) (lr) $t_{C(VCLK2)} + 2$	2^{25} (hr) (lr) $t_{C(VCLK2)} - 2$	ns

(1) hr = High-resolution prescaler, configured using the HRPFC field of the Prescale Factor Register (HETPFR).

(2) lr = Loop-resolution prescaler, configured using the LFPRC field of the Prescale Factor Register (HETPFR).

Both N2HET1 and N2HET2 have channels that are enhanced to be able to capture inputs with smaller pulse widths than that specified in Table 7-11. See Table 7-13 for a list of which pins support small pulse capture.

The input capture capability for these channels is specified in Table 7-12.

Table 7-12. Input Timing Requirements for N2HET Channels with Enhanced Pulse Capture

NO.		MIN	MAX	UNIT
1	Input signal period, PCNT or WCAP for rising edge to rising edge	(hr) (lr) $t_{C(VCLK2)} + 2$	2^{25} (hr) (lr) $t_{C(VCLK2)} - 2$	ns
2	Input signal period, PCNT or WCAP for falling edge to falling edge	(hr) (lr) $t_{C(VCLK2)} + 2$	2^{25} (hr) (lr) $t_{C(VCLK2)} - 2$	ns
3	Input signal high phase, PCNT or WCAP for rising edge to falling edge	2 (hr) $t_{C(VCLK2)} + 2$	2^{25} (hr) (lr) $t_{C(VCLK2)} - 2$	ns
4	Input signal low phase, PCNT or WCAP for falling edge to rising edge	2 (hr) $t_{C(VCLK2)} + 2$	2^{25} (hr) (lr) $t_{C(VCLK2)} - 2$	ns

Table 7-13. Input Capture Pin Capability

CHANNEL	SUPPORTS 32-BIT CAPTURE	ENHANCED PULSE CAPTURE
N2HET1[00]	Yes	No
N2HET1[01]	Yes	No
N2HET1[02]	Yes	No
N2HET1[03]	Yes	No
N2HET1[04]	Yes	No
N2HET1[05]	Yes	No
N2HET1[06]	Yes	No
N2HET1[07]	Yes	No
N2HET1[08]	Yes	No
N2HET1[09]	Yes	No
N2HET1[10]	Yes	No
N2HET1[11]	Yes	No
N2HET1[12]	Yes	No
N2HET1[13]	Yes	No
N2HET1[14]	Yes	No
N2HET1[15]	Yes	Yes
N2HET1[16]	Yes	No
N2HET1[17]	Yes	No
N2HET1[18]	Yes	No
N2HET1[19]	Yes	No
N2HET1[20]	Yes	Yes

Table 7-13. Input Capture Pin Capability (continued)

CHANNEL	SUPPORTS 32-BIT CAPTURE	ENHANCED PULSE CAPTURE
N2HET1[21]	Yes	No
N2HET1[22]	Yes	No
N2HET1[23]	Yes	No
N2HET1[24]	Yes	No
N2HET1[25]	Yes	No
N2HET1[26]	Yes	No
N2HET1[27]	Yes	No
N2HET1[28]	Yes	No
N2HET1[29]	Yes	No
N2HET1[30]	Yes	No
N2HET1[31]	Yes	Yes
N2HET2[00]	Yes	No
N2HET2[01]	No	No
N2HET2[02]	No	No
N2HET2[03]	No	No
N2HET2[04]	Yes	No
N2HET2[05]	No	No
N2HET2[06]	Yes	No
N2HET2[07]	No	No
N2HET2[08]	No	No
N2HET2[09]	No	No
N2HET2[10]	No	No
N2HET2[11]	No	No
N2HET2[12]	Yes	Yes
N2HET2[13]	No	No
N2HET2[14]	Yes	Yes
N2HET2[15]	No	No
N2HET2[16]	Yes	Yes
N2HET2[18]	No	No

7.4.4 N2HET1-N2HET2 Interconnections

In some applications the N2HET resolutions must be synchronized. Some other applications require a single time base to be used for all PWM outputs and input timing captures.

The N2HET provides such a synchronization mechanism. The Clk_master/slave (HETGCR.16) configures the N2HET in master or slave mode (default is slave mode). A N2HET in master mode provides a signal to synchronize the prescalers of the slave N2HET. The slave N2HET synchronizes its loop resolution to the loop resolution signal sent by the master. The slave does not require this signal after it receives the first synchronization signal. However, anytime the slave receives the resynchronization signal from the master, the slave must synchronize itself again..

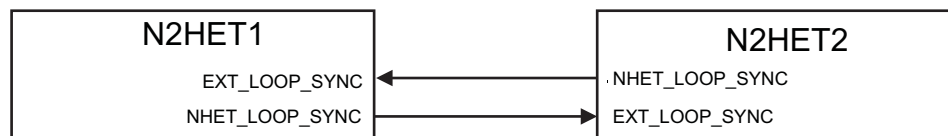

Figure 7-6. N2HET1 – N2HET2 Synchronization Hookup

7.4.5 N2HET Checking

7.4.5.1 Internal Monitoring

To assure correctness of the high-end timer operation and output signals, the two N2HET modules can be used to monitor each other's signals as shown in Figure 7-7. The direction of the monitoring is controlled by the I/O multiplexing control module.

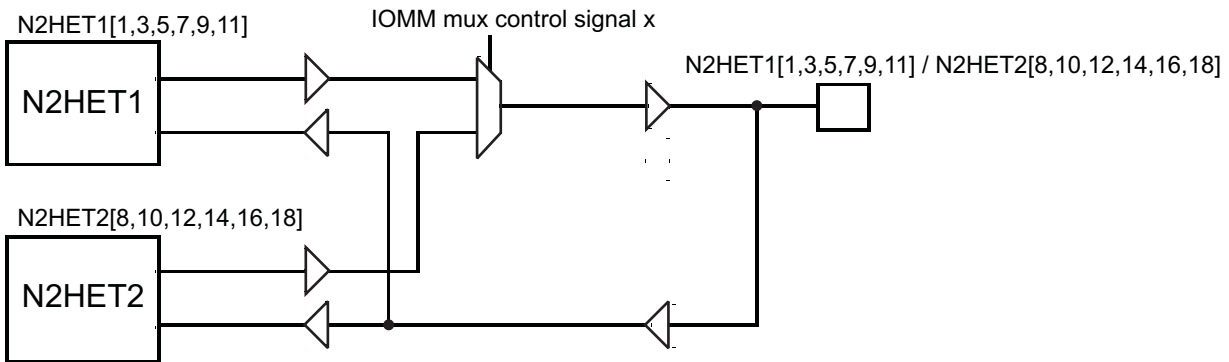

Figure 7-7. N2HET Monitoring

7.4.5.2 Output Monitoring Using Dual Clock Comparator (DCC)

N2HET1[31] is connected as a clock source for counter 1 in DCC1. This allows the application to measure the frequency of the pulse-width modulated (PWM) signal on N2HET1[31].

Similarly, N2HET2[0] is connected as a clock source for counter 1 in DCC2. This allows the application to measure the frequency of the pulse-width modulated (PWM) signal on N2HET2[0].

Both N2HET1[31] and N2HET2[0] can be configured to be internal-only channels. That is, the connection to the DCC module is made directly from the output of the N2HETx module (from the input of the output buffer).

For more information on DCC see [Section 6.7.3](#).

7.4.6 Disabling N2HET Outputs

Some applications require the N2HET outputs to be disabled under some fault condition. The N2HET module provides this capability via the "Pin Disable" input signal. This signal, when driven low, causes the N2HET outputs identified by a programmable register (HETPINDIS) to be tri-stated. See the device specific technical reference manual for more details on the "N2HET Pin Disable" feature.

GIOA[5] is connected to the "Pin Disable" input for N2HET1, and GIOB[2] is connected to the "Pin Disable" input for N2HET2.

7.4.7 High-End Timer Transfer Unit (HTU)

A High End Timer Transfer Unit (HTU) can perform DMA type transactions to transfer N2HET data to or from main memory. A Memory Protection Unit (MPU) is built into the HTU.

7.4.7.1 Features

- CPU and DMA independent
- Master Port to access system memory
- 8 control packets supporting dual buffer configuration
- Control packet information is stored in RAM protected by parity
- Event synchronization (HET transfer requests)
- Supports 32- or 64-bit transactions
- Addressing modes for HET address (8 byte or 16 byte) and system memory address (fixed, 32 bit or 64 bit)
- One shot, circular and auto switch buffer transfer modes
- Request lost detection

7.4.7.2 Trigger Connections

Table 7-14. HTU1 Request Line Connection

MODULES	REQUEST SOURCE	HTU1 REQUEST
N2HET1	HTUREQ[0]	HTU1 DCP[0]
N2HET1	HTUREQ[1]	HTU1 DCP[1]
N2HET1	HTUREQ[2]	HTU1 DCP[2]
N2HET1	HTUREQ[3]	HTU1 DCP[3]
N2HET1	HTUREQ[4]	HTU1 DCP[4]
N2HET1	HTUREQ[5]	HTU1 DCP[5]
N2HET1	HTUREQ[6]	HTU1 DCP[6]
N2HET1	HTUREQ[7]	HTU1 DCP[7]

Table 7-15. HTU2 Request Line Connection

MODULES	REQUEST SOURCE	HTU2 REQUEST
N2HET2	HTUREQ[0]	HTU2 DCP[0]
N2HET2	HTUREQ[1]	HTU2 DCP[1]
N2HET2	HTUREQ[2]	HTU2 DCP[2]
N2HET2	HTUREQ[3]	HTU2 DCP[3]
N2HET2	HTUREQ[4]	HTU2 DCP[4]
N2HET2	HTUREQ[5]	HTU2 DCP[5]
N2HET2	HTUREQ[6]	HTU2 DCP[6]
N2HET2	HTUREQ[7]	HTU2 DCP[7]

7.5 Controller Area Network (DCAN)

The DCAN supports the CAN 2.0B protocol standard and uses a serial, multimaster communication protocol that efficiently supports distributed real-time control with robust communication rates of up to 1 Mbps. The DCAN is ideal for applications operating in noisy and harsh environments (for example, automotive and industrial fields) that require reliable serial communication or multiplexed wiring.

7.5.1 Features

Features of the DCAN module include:

- Supports CAN protocol version 2.0 part A, B
- Bit rates up to 1 Mbps
- The CAN kernel can be clocked by the oscillator for baud-rate generation.
- 64 mailboxes on each DCAN
- Individual identifier mask for each message object
- Programmable FIFO mode for message objects
- Programmable loop-back modes for self-test operation
- Automatic bus on after Bus-Off state by a programmable 32-bit timer
- Message RAM protected by parity
- Direct access to Message RAM during test mode
- CAN Rx / Tx pins configurable as general purpose IO pins
- Message RAM Auto Initialization
- DMA support

For more information on the DCAN, see the RM48x 16/32-Bit RISC Flash Microcontroller Technical Reference Manual ([SPNU503](#)).

7.5.2 Electrical and Timing Specifications

Table 7-16. Dynamic Characteristics for the DCANx TX and RX Pins

PARAMETER		MIN	MAX	UNIT
$t_{d(CANnTX)}$	Delay time, transmit shift register to CANnTX pin ⁽¹⁾		15	ns
$t_{d(CANnRX)}$	Delay time, CANnRX pin to receive shift register		5	ns

(1) These values do not include rise/fall times of the output buffer.

7.6 Local Interconnect Network Interface (LIN)

The SCI/LIN module can be programmed to work either as an SCI or as a LIN. The core of the module is an SCI. The hardware features of the SCI are augmented to achieve LIN compatibility.

The SCI module is a universal asynchronous receiver-transmitter that implements the standard nonreturn to zero format. The SCI can be used to communicate, for example, through an RS-232 port or over a K-line.

The LIN standard is based on the SCI (UART) serial data link format. The communication concept is single-master/multiple-slave with a message identification for multicast transmission between any network nodes.

7.6.1 LIN Features

The following are features of the LIN module:

- Compatible to LIN 1.3, 2.0, and 2.1 protocols
- Multibuffered receive and transmit units DMA capability for minimal CPU intervention
- Identification masks for message filtering
- Automatic Master Header Generation
 - Programmable Synch Break Field
 - Synch Field
 - Identifier Field
- Slave Automatic Synchronization
 - Synch break detection
 - Optional baudrate update
 - Synchronization Validation
- 2^{31} programmable transmission rates with 7 fractional bits
- Error detection
- 2 Interrupt lines with priority encoding

7.7 Serial Communication Interface (SCI)

7.7.1 Features

- Standard universal asynchronous receiver-transmitter (UART) communication
- Supports full- or half-duplex operation
- Standard nonreturn to zero (NRZ) format
- Double-buffered receive and transmit functions
- Configurable frame format of 3 to 13 bits per character based on the following:
 - Data word length programmable from 1 to 8 bits
 - Additional address bit in address-bit mode
 - Parity programmable for zero or 1 parity bit, odd or even parity
 - Stop programmable for 1 or 2 stop bits
- Asynchronous or isosynchronous communication modes
- Two multiprocessor communication formats allow communication between more than two devices.
- Sleep mode is available to free CPU resources during multiprocessor communication.
- The 24-bit programmable baud rate supports 2^{24} different baud rates provide high accuracy baud rate selection.
- Four error flags and five status flags provide detailed information regarding SCI events.
- Capability to use DMA for transmit and receive data.

7.8 Inter-Integrated Circuit (I2C)

The inter-integrated circuit (I2C) module is a multimaster communication module providing an interface between the RM4x microcontroller and devices compliant with Philips Semiconductor I2C-bus specification version 2.1 and connected by an I²C-bus™. This module will support any slave or master I2C compatible device.

7.8.1 Features

The I2C has the following features:

- Compliance to the Philips I²C-bus specification, v2.1 (The I2C Specification, Philips document number 9398 393 40011)
 - Bit/Byte format transfer
 - 7-bit and 10-bit device addressing modes
 - General call
 - START byte
 - Multimaster transmitter/ slave receiver mode
 - Multimaster receiver/ slave transmitter mode
 - Combined master transmit/receive and receive/transmit mode
 - Transfer rates of 10 kbps up to 400 kbps (Phillips fast-mode rate)
- Free data format
- Two DMA events (transmit and receive)
- DMA event enable/disable capability
- Seven interrupts that can be used by the CPU
- Module enable/disable capability
- The SDA and SCL are optionally configurable as general-purpose I/O
- Slew rate control of the outputs
- Open-drain control of the outputs
- Programmable pullup/pulldown capability on the inputs
- Supports Ignore NACK mode

NOTE

This I2C module does not support:

- High-speed (HS) mode
 - C-bus compatibility mode
 - The combined format in 10-bit address mode (the I2C module sends the slave address second byte every time it sends the slave address first byte)
-

7.8.2 I2C I/O Timing Specifications

Table 7-17. I2C Signals (SDA and SCL) Switching Characteristics⁽¹⁾

PARAMETER		STANDARD MODE		FAST MODE		UNIT
		MIN	MAX	MIN	MAX	
$t_{c(I2CCLK)}$	Cycle time, Internal Module clock for I2C, prescaled from VCLK	75.2	149	75.2	149	ns
$f_{(SCL)}$	SCL Clock frequency	0	100	0	400	kHz
$t_{c(SCL)}$	Cycle time, SCL	10		2.5		μ s
$t_{su(SCLH-SDAL)}$	Setup time, SCL high before SDA low (for a repeated START condition)	4.7		0.6		μ s
$t_{h(SCLL-SDAL)}$	Hold time, SCL low after SDA low (for a repeated START condition)	4		0.6		μ s
$t_{w(SCLL)}$	Pulse duration, SCL low	4.7		1.3		μ s
$t_{w(SCLH)}$	Pulse duration, SCL high	4		0.6		μ s
$t_{su(SDA-SCLH)}$	Setup time, SDA valid before SCL high	250		100		ns
$t_{h(SDA-SCLL)}$	Hold time, SDA valid after SCL low (for I2C bus devices)	0	3.45 ⁽²⁾	0	0.9	μ s
$t_{w(SDAH)}$	Pulse duration, SDA high between STOP and START conditions	4.7		1.3		μ s
$t_{su(SCLH-SDAH)}$	Setup time, SCL high before SDA high (for STOP condition)	4.0		0.6		μ s
$t_{w(SP)}$	Pulse duration, spike (must be suppressed)			0	50	ns
C_b ⁽³⁾	Capacitive load for each bus line		400		400	pF

- (1) The I2C pins SDA and SCL do not feature fail-safe I/O buffers. These pins could potentially draw current when the device is powered down.
- (2) The maximum $t_{h(SDA-SCLL)}$ for I2C bus devices has only to be met if the device does not stretch the low period ($t_{w(SCLL)}$) of the SCL signal.
- (3) C_b = The total capacitance of one bus line in pF.

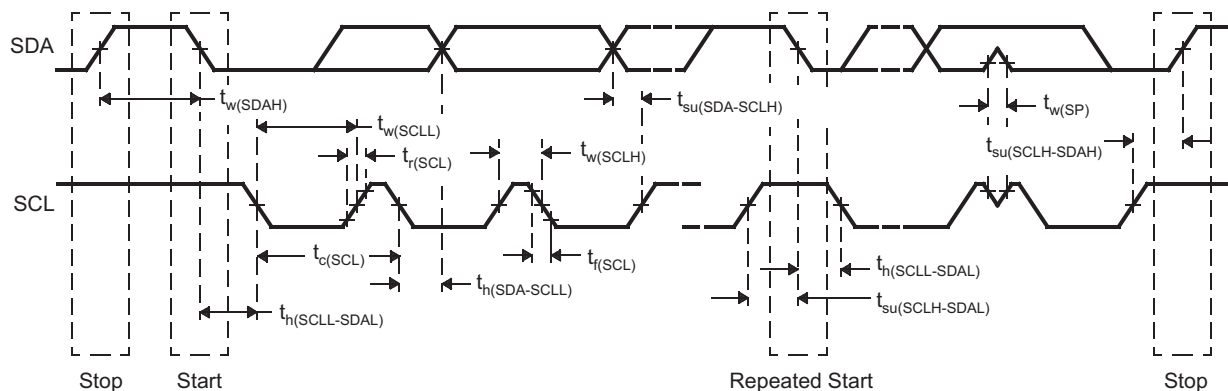

Figure 7-8. I2C Timings

NOTE

- A device must internally provide a hold time of at least 300 ns for the SDA signal (referred to the VIHmin of the SCL signal) to bridge the undefined region of the falling edge of SCL.
 - The maximum $t_{h(SDA-SCLL)}$ has only to be met if the device does not stretch the LOW period ($t_{w(SCLL)}$) of the SCL signal.
 - A Fast-mode I2C-bus device can be used in a Standard-mode I2C-bus system, but the requirement $t_{su(SDA-SCLH)} \geq 250$ ns must then be met. This will automatically be the case if the device does not stretch the LOW period of the SCL signal. If such a device does stretch the LOW period of the SCL signal, it must output the next data bit to the SDA line $t_{r\ max} + t_{su(SDA-SCLH)}$.
 - C_b = total capacitance of one bus line in pF. If mixed with fast-mode devices, faster fall-times are allowed.
-

7.9 Multibuffered / Standard Serial Peripheral Interface

The MibSPI is a high-speed synchronous serial input/output port that allows a serial bit stream of programmed length (2 to 16 bits) to be shifted in and out of the device at a programmed bit-transfer rate. Typical applications for the SPI include interfacing to external peripherals, such as I/Os, memories, display drivers, and analog-to-digital converters.

7.9.1 Features

Both Standard and MibSPI modules have the following features:

- 16-bit shift register
- Receive buffer register
- 5-bit baud clock generator
- SPICLK can be internally-generated (master mode) or received from an external clock source (slave mode)
- Each word transferred can have a unique format
- SPI I/Os not used in the communication can be used as digital input/output signals

Table 7-18. MibSPI/SPI Configurations

MibSPIx/SPIx	I/Os
MibSPI1	MIBSPI1SIMO[1:0], MIBSPI1SOMI[1:0], MIBSPI1CLK, MIBSPI1nCS[5:0], MIBSPI1nENA
MibSPI3	MIBSPI3SIMO, MIBSPI3SOMI, MIBSPI3CLK, MIBSPI3nCS[5:0], MIBSPI3nENA
MibSPI5	MIBSPI5SIMO[3:0], MIBSPI5SOMI[3:0], MIBSPI5CLK, MIBSPI5nCS[3:0], MIBSPI5nENA
SPI2	SPI2SIMO, SPI2SOMI, SPI2CLK, SPI2nCS[1:0], SPI2nENA
SPI4	SPI4SIMO, SPI4SOMI, SPI4CLK, SPI4nCS[0], SPI4nENA

7.9.2 MibSPI Transmit and Receive RAM Organization

The Multibuffer RAM is comprised of 128 buffers. Each entry in the Multibuffer RAM consists of 4 parts: a 16-bit transmit field, a 16-bit receive field, a 16-bit control field and a 16-bit status field. The Multibuffer RAM can be partitioned into multiple transfer group with variable number of buffers each.

7.9.3 MibSPI Transmit Trigger Events

Each of the transfer groups can be configured individually. For each of the transfer groups a trigger event and a trigger source can be chosen. A trigger event can be for example a rising edge or a permanent low level at a selectable trigger source. For example, up to 15 trigger sources are available which can be used by each transfer group. These trigger options are listed in [Table 7-19](#) for MIBSPI1, [Section 7.9.3.2](#) for MIBSPI3 and [Section 7.9.3.3](#) for MibSPI5.

7.9.3.1 MIBSPI1 Event Trigger Hookup

Table 7-19. MIBSPI1 Event Trigger Hookup

EVENT #	TGxCTRL TRIGSRC[3:0]	TRIGGER
Disabled	0000	No trigger source
EVENT0	0001	GIOA[0]
EVENT1	0010	GIOA[1]
EVENT2	0011	GIOA[2]
EVENT3	0100	GIOA[3]
EVENT4	0101	GIOA[4]
EVENT5	0110	GIOA[5]
EVENT6	0111	GIOA[6]
EVENT7	1000	GIOA[7]
EVENT8	1001	N2HET1[8]
EVENT9	1010	N2HET1[10]
EVENT10	1011	N2HET1[12]
EVENT11	1100	N2HET1[14]
EVENT12	1101	N2HET1[16]
EVENT13	1110	N2HET1[18]
EVENT14	1111	Internal Tick counter

NOTE

For N2HET1 trigger sources, the connection to the MibSPI1 module trigger input is made from the input side of the output buffer (at the N2HET1 module boundary). This way, a trigger condition can be generated even if the N2HET1 signal is not selected to be output on the pad.

NOTE

For GIOx trigger sources, the connection to the MibSPI1 module trigger input is made from the output side of the input buffer. This way, a trigger condition can be generated either by selecting the GIOx pin as an output pin, or by driving the GIOx pin from an external trigger source.

7.9.3.2 MIBSPI3 Event Trigger Hookup

Table 7-20. MIBSPI3 Event Trigger Hookup

EVENT #	TGxCTRL TRIGSRC[3:0]	TRIGGER
Disabled	0000	No trigger source
EVENT0	0001	GIOA[0]
EVENT1	0010	GIOA[1]
EVENT2	0011	GIOA[2]
EVENT3	0100	GIOA[3]
EVENT4	0101	GIOA[4]
EVENT5	0110	GIOA[5]
EVENT6	0111	GIOA[6]
EVENT7	1000	GIOA[7]
EVENT8	1001	HET[8]
EVENT9	1010	N2HET1[10]
EVENT10	1011	N2HET1[12]
EVENT11	1100	N2HET1[14]

Table 7-20. MIBSPI3 Event Trigger Hookup (continued)

EVENT #	TGxCTRL TRIGSRC[3:0]	TRIGGER
EVENT12	1101	N2HET1[16]
EVENT13	1110	N2HET1[18]
EVENT14	1111	Internal Tick counter

NOTE

For N2HET1 trigger sources, the connection to the MibSPI3 module trigger input is made from the input side of the output buffer (at the N2HET1 module boundary). This way, a trigger condition can be generated even if the N2HET1 signal is not selected to be output on the pad.

NOTE

For GIOx trigger sources, the connection to the MibSPI3 module trigger input is made from the output side of the input buffer. This way, a trigger condition can be generated either by selecting the GIOx pin as an output pin, or by driving the GIOx pin from an external trigger source.

7.9.3.3 MIBSPI5 Event Trigger Hookup**Table 7-21. MIBSPI5 Event Trigger Hookup**

EVENT #	TGxCTRL TRIGSRC[3:0]	TRIGGER
Disabled	0000	No trigger source
EVENT0	0001	GIOA[0]
EVENT1	0010	GIOA[1]
EVENT2	0011	GIOA[2]
EVENT3	0100	GIOA[3]
EVENT4	0101	GIOA[4]
EVENT5	0110	GIOA[5]
EVENT6	0111	GIOA[6]
EVENT7	1000	GIOA[7]
EVENT8	1001	N2HET1[8]
EVENT9	1010	N2HET1[10]
EVENT10	1011	N2HET1[12]
EVENT11	1100	N2HET1[14]
EVENT12	1101	N2HET1[16]
EVENT13	1110	N2HET1[18]
EVENT14	1111	Internal Tick counter

NOTE

For N2HET1 trigger sources, the connection to the MibSPI5 module trigger input is made from the input side of the output buffer (at the N2HET1 module boundary). This way, a trigger condition can be generated even if the N2HET1 signal is not selected to be output on the pad.

NOTE

For GIOx trigger sources, the connection to the MibSPI5 module trigger input is made from the output side of the input buffer. This way, a trigger condition can be generated either by selecting the GIOx pin as an output pin + selecting the pin to be a GIOx pin, or by driving the GIOx pin from an external trigger source. If the mux control module is used to select different functionality instead of the GIOx signal, then care must be taken to disable GIOx from triggering MibSPI5 transfers; there is no multiplexing on the input connections.

7.9.4 MibSPI/SPI Master Mode I/O Timing Specifications

Table 7-22. SPI Master Mode External Timing Parameters (CLOCK PHASE = 0, SPICLK = output, SPISIMO = output, and SPISOMI = input)⁽¹⁾⁽²⁾⁽³⁾

NO.	PARAMETER		MIN	MAX	UNIT	
1	$t_{c(SPC)M}$	Cycle time, SPICLK ⁽⁴⁾	40	$256t_{c(VCLK)}$	ns	
2 ⁽⁵⁾	$t_{w(SPCH)M}$	Pulse duration, SPICLK high (clock polarity = 0)	$0.5t_{c(SPC)M} - t_{r(SPC)M} - 3$	$0.5t_{c(SPC)M} + 3$	ns	
	$t_{w(SPCL)M}$	Pulse duration, SPICLK low (clock polarity = 1)	$0.5t_{c(SPC)M} - t_{r(SPC)M} - 3$	$0.5t_{c(SPC)M} + 3$		
3 ⁽⁵⁾	$t_{w(SPCL)M}$	Pulse duration, SPICLK low (clock polarity = 0)	$0.5t_{c(SPC)M} - t_{r(SPC)M} - 3$	$0.5t_{c(SPC)M} + 3$	ns	
	$t_{w(SPCH)M}$	Pulse duration, SPICLK high (clock polarity = 1)	$0.5t_{c(SPC)M} - t_{r(SPC)M} - 3$	$0.5t_{c(SPC)M} + 3$		
4 ⁽⁵⁾	$t_{d(SPCH-SIMO)M}$	Delay time, SPISIMO valid before SPICLK low (clock polarity = 0)	$0.5t_{c(SPC)M} - 6$		ns	
	$t_{d(SPCL-SIMO)M}$	Delay time, SPISIMO valid before SPICLK high (clock polarity = 1)	$0.5t_{c(SPC)M} - 6$			
5 ⁽⁵⁾	$t_{v(SPCL-SIMO)M}$	Valid time, SPISIMO data valid after SPICLK low (clock polarity = 0)	$0.5t_{c(SPC)M} - t_{f(SPC)} - 4$		ns	
	$t_{v(SPCH-SIMO)M}$	Valid time, SPISIMO data valid after SPICLK high (clock polarity = 1)	$0.5t_{c(SPC)M} - t_{f(SPC)} - 4$			
6 ⁽⁵⁾	$t_{su(SOMI-SPCL)M}$	Setup time, SPISOMI before SPICLK low (clock polarity = 0)	$t_{f(SPC)} + 2.2$		ns	
	$t_{su(SOMI-SPCH)M}$	Setup time, SPISOMI before SPICLK high (clock polarity = 1)	$t_{f(SPC)} + 2.2$			
7 ⁽⁵⁾	$t_{h(SPCL-SOMI)M}$	Hold time, SPISOMI data valid after SPICLK low (clock polarity = 0)	10		ns	
	$t_{h(SPCH-SOMI)M}$	Hold time, SPISOMI data valid after SPICLK high (clock polarity = 1)	10			
8 ⁽⁶⁾	$t_{C2TDELAY}$	Setup time CS active until SPICLK high (clock polarity = 0)	CSHOLD = 0	$C2TDELAY * t_{c(VCLK)} + 2 * t_{c(VCLK)} - t_{f(SPICS)} + t_{r(SPC)} - 7$	$(C2TDELAY + 2) * t_{c(VCLK)} - t_{f(SPICS)} + t_{r(SPC)} + 5.5$	ns
			CSHOLD = 1	$C2TDELAY * t_{c(VCLK)} + 3 * t_{c(VCLK)} - t_{f(SPICS)} + t_{r(SPC)} - 7$	$(C2TDELAY + 3) * t_{c(VCLK)} - t_{f(SPICS)} + t_{r(SPC)} + 5.5$	
		Setup time CS active until SPICLK low (clock polarity = 1)	CSHOLD = 0	$C2TDELAY * t_{c(VCLK)} + 2 * t_{c(VCLK)} - t_{f(SPICS)} + t_{f(SPC)} - 7$	$(C2TDELAY + 2) * t_{c(VCLK)} - t_{f(SPICS)} + t_{f(SPC)} + 5.5$	
			CSHOLD = 1	$C2TDELAY * t_{c(VCLK)} + 3 * t_{c(VCLK)} - t_{f(SPICS)} + t_{f(SPC)} - 7$	$(C2TDELAY + 3) * t_{c(VCLK)} - t_{f(SPICS)} + t_{f(SPC)} + 5.5$	
9 ⁽⁶⁾	$t_{T2CDELAY}$	Hold time SPICLK low until CS inactive (clock polarity = 0)	$0.5 * t_{c(SPC)M} + T2CDELAY * t_{c(VCLK)} + t_{c(VCLK)} - t_{f(SPC)} + t_{r(SPICS)} - 7$	$0.5 * t_{c(SPC)M} + T2CDELAY * t_{c(VCLK)} + t_{c(VCLK)} - t_{f(SPC)} + t_{r(SPICS)} + 11$	ns	
		Hold time SPICLK high until CS inactive (clock polarity = 1)	$0.5 * t_{c(SPC)M} + T2CDELAY * t_{c(VCLK)} + t_{c(VCLK)} - t_{r(SPC)} + t_{r(SPICS)} - 7$	$0.5 * t_{c(SPC)M} + T2CDELAY * t_{c(VCLK)} + t_{c(VCLK)} - t_{r(SPC)} + t_{r(SPICS)} + 11$		
10	t_{SPIENA}	SPIENAn Sample point	$(C2TDELAY + 1) * t_{c(VCLK)} - t_{f(SPICS)} - 29$	$(C2TDELAY + 1) * t_{c(VCLK)}$	ns	
11	$t_{SPIENAW}$	SPIENAn Sample point from write to buffer		$(C2TDELAY + 2) * t_{c(VCLK)}$	ns	

(1) The MASTER bit (SPIGCR1.0) is set and the CLOCK PHASE bit (SPIFMTx.16) is cleared.

(2) $t_{c(VCLK)}$ = interface clock cycle time = $1 / f_{(VCLK)}$

(3) For rise and fall timings, see [Table 5-7](#).

(4) When the SPI is in Master mode, the following must be true:

For PS values from 1 to 255: $t_{c(SPC)M} \geq (PS + 1)t_{c(VCLK)} \geq 40ns$, where PS is the prescale value set in the SPIFMTx.[15:8] register bits.

For PS values of 0: $t_{c(SPC)M} = 2t_{c(VCLK)} \geq 40ns$.

The external load on the SPICLK pin must be less than 60pF.

(5) The active edge of the SPICLK signal referenced is controlled by the CLOCK POLARITY bit (SPIFMTx.17).

(6) C2TDELAY and T2CDELAY is programmed in the SPIDELAY register

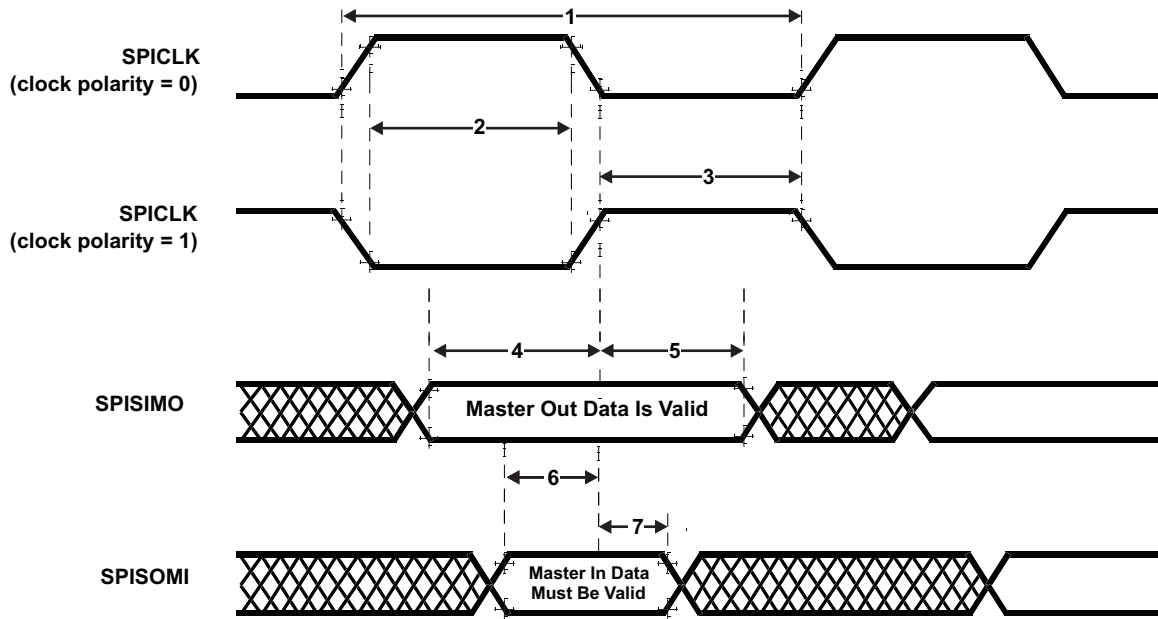

Figure 7-9. SPI Master Mode External Timing (CLOCK PHASE = 0)

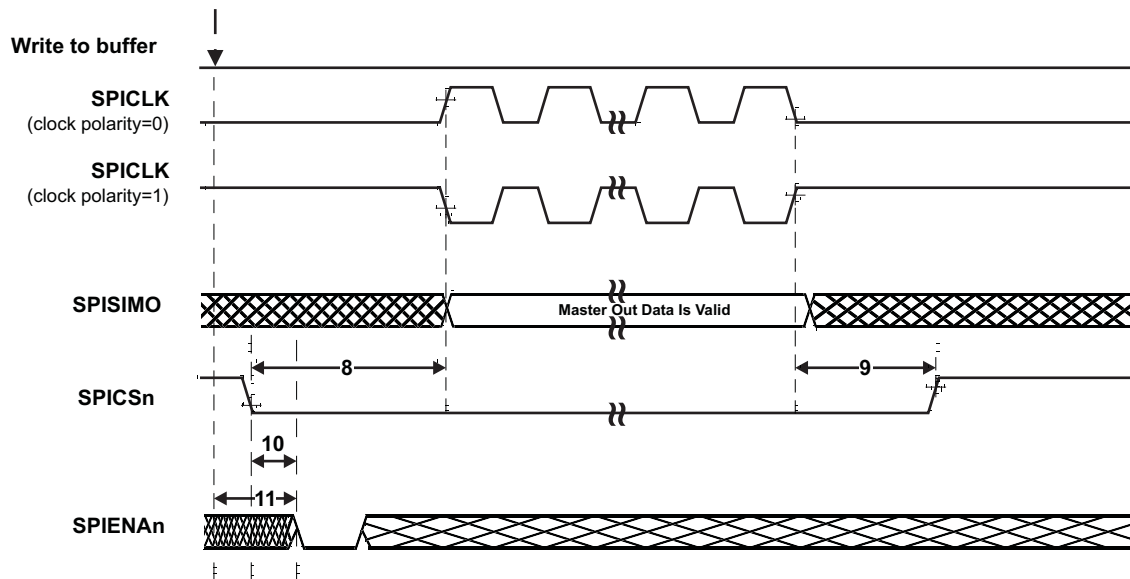

Figure 7-10. SPI Master Mode Chip Select Timing (CLOCK PHASE = 0)

Table 7-23. SPI Master Mode External Timing Parameters (CLOCK PHASE = 1, SPICLK = output, SPISIMO = output, and SPISOMI = input)⁽¹⁾⁽²⁾⁽³⁾

NO.	PARAMETER		MIN	MAX	UNIT	
1	$t_{c(SPC)M}$	Cycle time, SPICLK ⁽⁴⁾	40	$256t_{c(VCLK)}$	ns	
2 ⁽⁵⁾	$t_{w(SPCH)M}$	Pulse duration, SPICLK high (clock polarity = 0)	$0.5t_{c(SPC)M} - t_{f(SPC)M} - 3$	$0.5t_{c(SPC)M} + 3$	ns	
	$t_{w(SPCL)M}$	Pulse duration, SPICLK low (clock polarity = 1)	$0.5t_{c(SPC)M} - t_{f(SPC)M} - 3$	$0.5t_{c(SPC)M} + 3$		
3 ⁽⁵⁾	$t_{w(SPCL)M}$	Pulse duration, SPICLK low (clock polarity = 0)	$0.5t_{c(SPC)M} - t_{f(SPC)M} - 3$	$0.5t_{c(SPC)M} + 3$	ns	
	$t_{w(SPCH)M}$	Pulse duration, SPICLK high (clock polarity = 1)	$0.5t_{c(SPC)M} - t_{f(SPC)M} - 3$	$0.5t_{c(SPC)M} + 3$		
4 ⁽⁵⁾	$t_{v(SIMO-SPCH)M}$	Valid time, SPICLK high after SPISIMO data valid (clock polarity = 0)	$0.5t_{c(SPC)M} - 6$		ns	
	$t_{v(SIMO-SPCL)M}$	Valid time, SPICLK low after SPISIMO data valid (clock polarity = 1)	$0.5t_{c(SPC)M} - 6$			
5 ⁽⁵⁾	$t_{v(SPCH-SIMO)M}$	Valid time, SPISIMO data valid after SPICLK high (clock polarity = 0)	$0.5t_{c(SPC)M} - t_{f(SPC)} - 4$		ns	
	$t_{v(SPCL-SIMO)M}$	Valid time, SPISIMO data valid after SPICLK low (clock polarity = 1)	$0.5t_{c(SPC)M} - t_{f(SPC)} - 4$			
6 ⁽⁵⁾	$t_{su(SOMI-SPCH)M}$	Setup time, SPISOMI before SPICLK high (clock polarity = 0)	$t_{f(SPC)} + 2.2$		ns	
	$t_{su(SOMI-SPCL)M}$	Setup time, SPISOMI before SPICLK low (clock polarity = 1)	$t_{f(SPC)} + 2.2$			
7 ⁽⁵⁾	$t_{v(SPCH-SOMI)M}$	Valid time, SPISOMI data valid after SPICLK high (clock polarity = 0)	10		ns	
	$t_{v(SPCL-SOMI)M}$	Valid time, SPISOMI data valid after SPICLK low (clock polarity = 1)	10			
8 ⁽⁶⁾	$t_{C2TDELAY}$	Setup time CS active until SPICLK high (clock polarity = 0)	CSHOLD = 0	$0.5t_{c(SPC)M} + (C2TDELAY+2) * t_{c(VCLK)} - t_{f(SPICS)} + t_{f(SPC)} - 7$	$0.5t_{c(SPC)M} + (C2TDELAY+2) * t_{c(VCLK)} - t_{f(SPICS)} + t_{f(SPC)} + 5.5$	ns
			CSHOLD = 1	$0.5t_{c(SPC)M} + (C2TDELAY+3) * t_{c(VCLK)} - t_{f(SPICS)} + t_{f(SPC)} - 7$	$0.5t_{c(SPC)M} + (C2TDELAY+3) * t_{c(VCLK)} - t_{f(SPICS)} + t_{f(SPC)} + 5.5$	
		Setup time CS active until SPICLK low (clock polarity = 1)	CSHOLD = 0	$0.5t_{c(SPC)M} + (C2TDELAY+2) * t_{c(VCLK)} - t_{f(SPICS)} + t_{f(SPC)} - 7$	$0.5t_{c(SPC)M} + (C2TDELAY+2) * t_{c(VCLK)} - t_{f(SPICS)} + t_{f(SPC)} + 5.5$	
			CSHOLD = 1	$0.5t_{c(SPC)M} + (C2TDELAY+3) * t_{c(VCLK)} - t_{f(SPICS)} + t_{f(SPC)} - 7$	$0.5t_{c(SPC)M} + (C2TDELAY+3) * t_{c(VCLK)} - t_{f(SPICS)} + t_{f(SPC)} + 5.5$	
9 ⁽⁶⁾	$t_{T2CDELAY}$	Hold time SPICLK low until CS inactive (clock polarity = 0)	$T2CDELAY * t_{c(VCLK)} + t_{c(VCLK)} - t_{f(SPC)} + t_{f(SPICS)} - 7$	$T2CDELAY * t_{c(VCLK)} + t_{c(VCLK)} - t_{f(SPC)} + t_{f(SPICS)} + 11$	ns	
		Hold time SPICLK high until CS inactive (clock polarity = 1)	$T2CDELAY * t_{c(VCLK)} + t_{c(VCLK)} - t_{f(SPC)} + t_{f(SPICS)} - 7$	$T2CDELAY * t_{c(VCLK)} + t_{c(VCLK)} - t_{f(SPC)} + t_{f(SPICS)} + 11$		
10	t_{SPIENA}	SPIENAn Sample Point	$(C2TDELAY+1) * t_{c(VCLK)} - t_{f(SPICS)} - 29$	$(C2TDELAY+1) * t_{c(VCLK)}$	ns	
11	$t_{SPIENAW}$	SPIENAn Sample point from write to buffer		$(C2TDELAY+2) * t_{c(VCLK)}$	ns	

(1) The MASTER bit (SPIGCR1.0) is set and the CLOCK PHASE bit (SPIFMTx.16) is set.
 (2) $t_{c(VCLK)}$ = interface clock cycle time = $1 / f_{(VCLK)}$
 (3) For rise and fall timings, see the [Table 5-7](#).
 (4) When the SPI is in Master mode, the following must be true:
 For PS values from 1 to 255: $t_{c(SPC)M} \geq (PS + 1)t_{c(VCLK)} \geq 40ns$, where PS is the prescale value set in the SPIFMTx.[15:8] register bits.
 For PS values of 0: $t_{c(SPC)M} = 2t_{c(VCLK)} \geq 40ns$.
 The external load on the SPICLK pin must be less than 60pF.
 (5) The active edge of the SPICLK signal referenced is controlled by the CLOCK POLARITY bit (SPIFMTx.17).
 (6) C2TDELAY and T2CDELAY is programmed in the SPIDELAY register

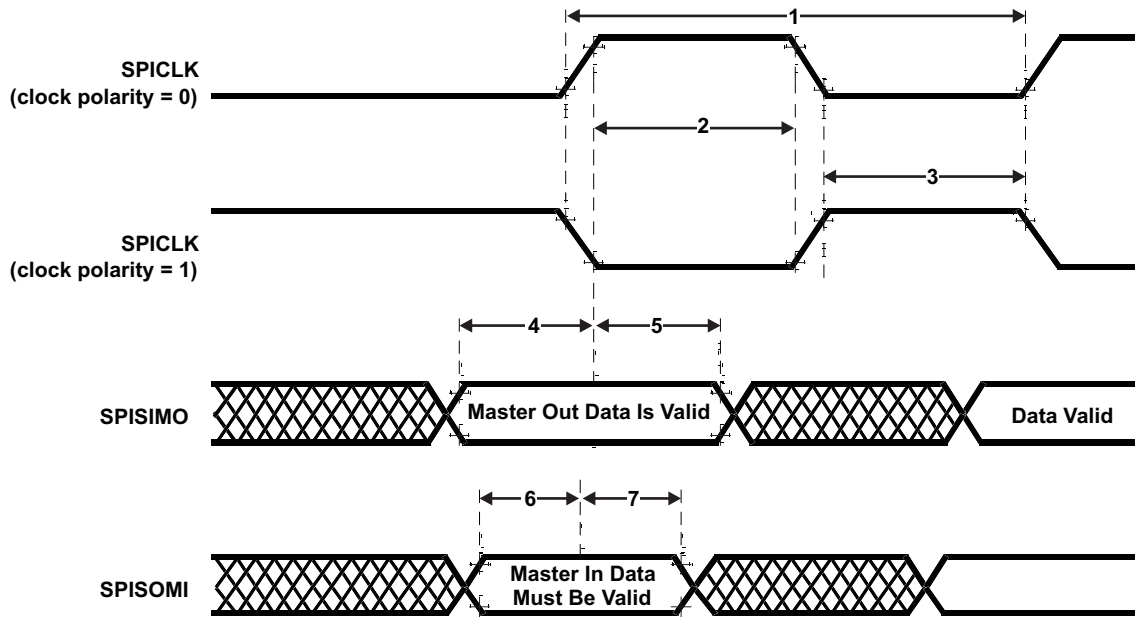

Figure 7-11. SPI Master Mode External Timing (CLOCK PHASE = 1)

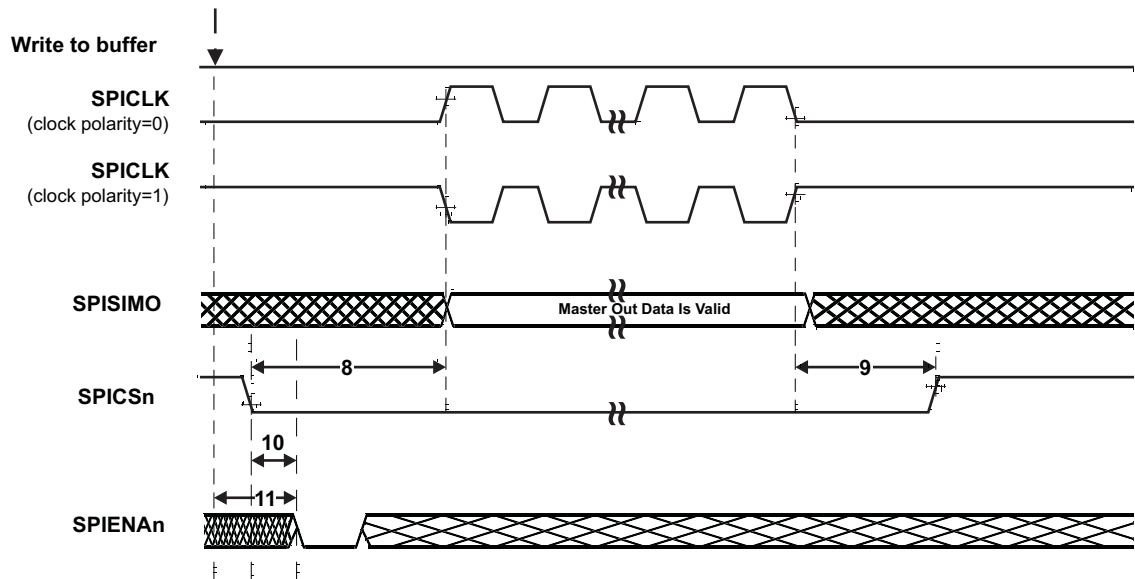

Figure 7-12. SPI Master Mode Chip Select Timing (CLOCK PHASE = 1)

7.9.5 SPI Slave Mode I/O Timings

Table 7-24. SPI Slave Mode External Timing Parameters (CLOCK PHASE = 0, SPICLK = input, SPISIMO = input, and SPISOMI = output)⁽¹⁾⁽²⁾⁽³⁾⁽⁴⁾

NO.	PARAMETER		MIN	MAX	UNIT
1	$t_{c(SPC)S}$	Cycle time, SPICLK ⁽⁵⁾	40		ns
2 ⁽⁶⁾	$t_{w(SPCH)S}$	Pulse duration, SPICLK high (clock polarity = 0)	14		ns
	$t_{w(SPCL)S}$	Pulse duration, SPICLK low (clock polarity = 1)	14		
3 ⁽⁶⁾	$t_{w(SPCL)S}$	Pulse duration, SPICLK low (clock polarity = 0)	14		ns
	$t_{w(SPCH)S}$	Pulse duration, SPICLK high (clock polarity = 1)	14		
4 ⁽⁶⁾	$t_{d(SPCH-SOMI)S}$	Delay time, SPISOMI valid after SPICLK high (clock polarity = 0)		$t_{r(SOMI)} + 20$	ns
	$t_{d(SPCL-SOMI)S}$	Delay time, SPISOMI valid after SPICLK low (clock polarity = 1)		$t_{r(SOMI)} + 20$	
5 ⁽⁶⁾	$t_{h(SPCH-SOMI)S}$	Hold time, SPISOMI data valid after SPICLK high (clock polarity = 0)	2		ns
	$t_{h(SPCL-SOMI)S}$	Hold time, SPISOMI data valid after SPICLK low (clock polarity = 1)	2		
6 ⁽⁶⁾	$t_{su(SIMO-SPCL)S}$	Setup time, SPISIMO before SPICLK low (clock polarity = 0)	4		ns
	$t_{su(SIMO-SPCH)S}$	Setup time, SPISIMO before SPICLK high (clock polarity = 1)	4		
7 ⁽⁶⁾	$t_{h(SPCL-SIMO)S}$	Hold time, SPISIMO data valid after SPICLK low (clock polarity = 0)	2		ns
	$t_{h(SPCH-SIMO)S}$	Hold time, SPISIMO data valid after SPICLK high (clock polarity = 1)	2		
8	$t_{d(SPCL-SENAH)S}$	Delay time, SPIENAn high after last SPICLK low (clock polarity = 0)	$1.5t_{c(VCLK)}$	$2.5t_{c(VCLK)} + t_{r(ENAn)} + 22$	ns
	$t_{d(SPCH-SENAH)S}$	Delay time, SPIENAn high after last SPICLK high (clock polarity = 1)	$1.5t_{c(VCLK)}$	$2.5t_{c(VCLK)} + t_{r(ENAn)} + 22$	
9	$t_{d(SCSL-SENAL)S}$	Delay time, SPIENAn low after SPICLK low (if new data has been written to the SPI buffer)	$t_{r(ENAn)}$	$t_{c(VCLK)} + t_{r(ENAn)} + 27$	ns

- (1) The MASTER bit (SPIGCR1.0) is cleared and the CLOCK PHASE bit (SPIFMTx.16) is cleared.
- (2) If the SPI is in slave mode, the following must be true: $t_{c(SPC)S} \geq (PS + 1)t_{c(VCLK)}$, where PS = prescale value set in SPIFMTx.[15:8].
- (3) For rise and fall timings, see [Table 5-7](#).
- (4) $t_{c(VCLK)}$ = interface clock cycle time = $1/f_{(VCLK)}$
- (5) When the SPI is in Slave mode, the following must be true:
 For PS values from 1 to 255: $t_{c(SPC)S} \geq (PS + 1)t_{c(VCLK)} \geq 40ns$, where PS is the prescale value set in the SPIFMTx.[15:8] register bits.
 For PS values of 0: $t_{c(SPC)S} = 2t_{c(VCLK)} \geq 40ns$.
- (6) The active edge of the SPICLK signal referenced is controlled by the CLOCK POLARITY bit (SPIFMTx.17).

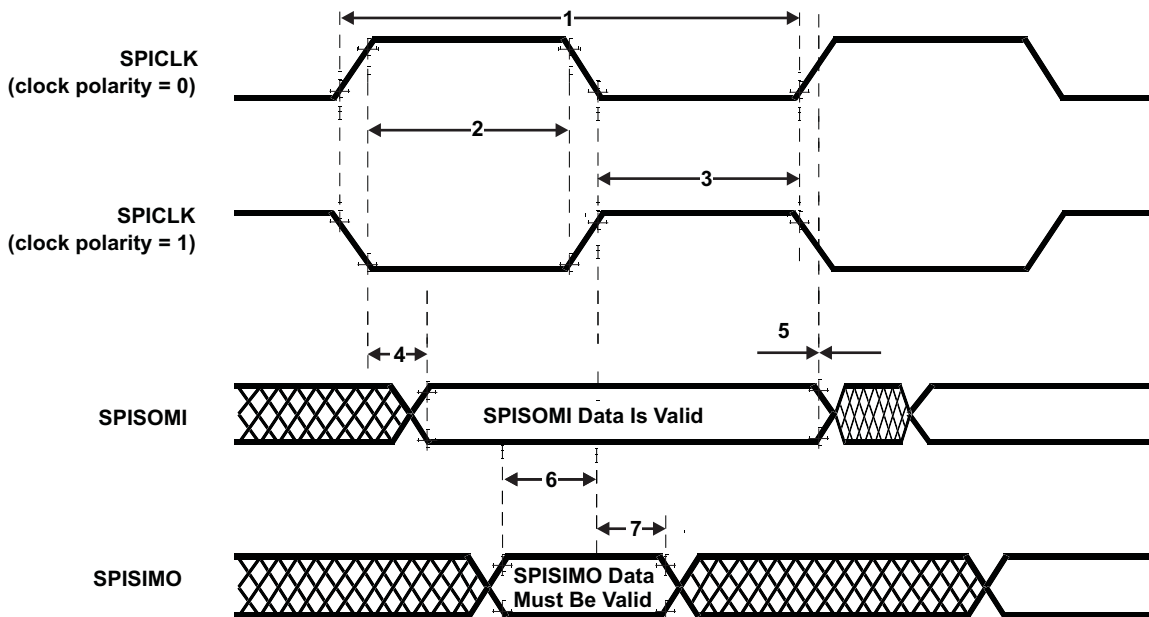

Figure 7-13. SPI Slave Mode External Timing (CLOCK PHASE = 0)

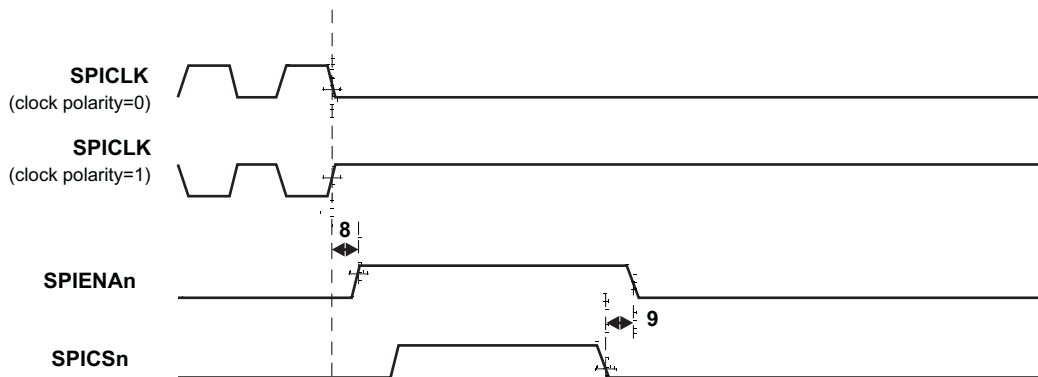

Figure 7-14. SPI Slave Mode Enable Timing (CLOCK PHASE = 0)

Table 7-25. SPI Slave Mode External Timing Parameters (CLOCK PHASE = 1, SPICLK = input, SPISIMO = input, and SPISOMI = output)⁽¹⁾⁽²⁾⁽³⁾⁽⁴⁾

NO.	PARAMETER		MIN	MAX	UNIT
1	$t_{c(SPC)S}$	Cycle time, SPICLK ⁽⁵⁾	40		ns
2 ⁽⁶⁾	$t_{w(SPCH)S}$	Pulse duration, SPICLK high (clock polarity = 0)	14		ns
	$t_{w(SPCL)S}$	Pulse duration, SPICLK low (clock polarity = 1)	14		
3 ⁽⁶⁾	$t_{w(SPCL)S}$	Pulse duration, SPICLK low (clock polarity = 0)	14		ns
	$t_{w(SPCH)S}$	Pulse duration, SPICLK high (clock polarity = 1)	14		
4 ⁽⁶⁾	$t_{d(SOMI-SPCL)S}$	Dealy time, SPISOMI data valid after SPICLK low (clock polarity = 0)		$t_{r(SOMI)} + 20$	ns
	$t_{d(SOMI-SPCH)S}$	Delay time, SPISOMI data valid after SPICLK high (clock polarity = 1)		$t_{r(SOMI)} + 20$	
5 ⁽⁶⁾	$t_{h(SPCL-SOMI)S}$	Hold time, SPISOMI data valid after SPICLK high (clock polarity = 0)	2		ns
	$t_{h(SPCH-SOMI)S}$	Hold time, SPISOMI data valid after SPICLK low (clock polarity = 1)	2		
6 ⁽⁶⁾	$t_{su(SIMO-SPCH)S}$	Setup time, SPISIMO before SPICLK high (clock polarity = 0)	4		ns
	$t_{su(SIMO-SPCL)S}$	Setup time, SPISIMO before SPICLK low (clock polarity = 1)	4		
7 ⁽⁶⁾	$t_{v(SPCH-SIMO)S}$	High time, SPISIMO data valid after SPICLK high (clock polarity = 0)	2		ns
	$t_{v(SPCL-SIMO)S}$	High time, SPISIMO data valid after SPICLK low (clock polarity = 1)	2		
8	$t_{d(SPCH-SENAH)S}$	Delay time, SPIENAn high after last SPICLK high (clock polarity = 0)	$1.5t_{c(VCLK)}$	$2.5t_{c(VCLK)} + t_{r(ENAn)} + 22$	ns
	$t_{d(SPCL-SENAH)S}$	Delay time, SPIENAn high after last SPICLK low (clock polarity = 1)	$1.5t_{c(VCLK)}$	$2.5t_{c(VCLK)} + t_{r(ENAn)} + 22$	
9	$t_{d(SCSL-SENAL)S}$	Delay time, SPIENAn low after SPICSn low (if new data has been written to the SPI buffer)	$t_{r(ENAn)}$	$t_{c(VCLK)} + t_{r(ENAn)} + 27$	ns
10	$t_{d(SCSL-SOMI)S}$	Delay time, SOMI valid after SPICSn low (if new data has been written to the SPI buffer)	$t_{c(VCLK)}$	$2t_{c(VCLK)} + t_{r(SOMI)} + 28$	ns

- (1) The MASTER bit (SPIGCR1.0) is cleared and the CLOCK PHASE bit (SPIFMTx.16) is set.
- (2) If the SPI is in slave mode, the following must be true: $t_{c(SPC)S} \leq (PS + 1) t_{c(VCLK)}$, where PS = prescale value set in SPIFMTx.[15:8].
- (3) For rise and fall timings, see [Table 5-7](#).
- (4) $t_{c(VCLK)}$ = interface clock cycle time = $1 / f_{(VCLK)}$
- (5) When the SPI is in Slave mode, the following must be true:
 For PS values from 1 to 255: $t_{c(SPC)S} \geq (PS + 1)t_{c(VCLK)} \geq 40ns$, where PS is the prescale value set in the SPIFMTx.[15:8] register bits.
 For PS values of 0: $t_{c(SPC)S} = 2t_{c(VCLK)} \geq 40ns$.
- (6) The active edge of the SPICLK signal referenced is controlled by the CLOCK POLARITY bit (SPIFMTx.17).

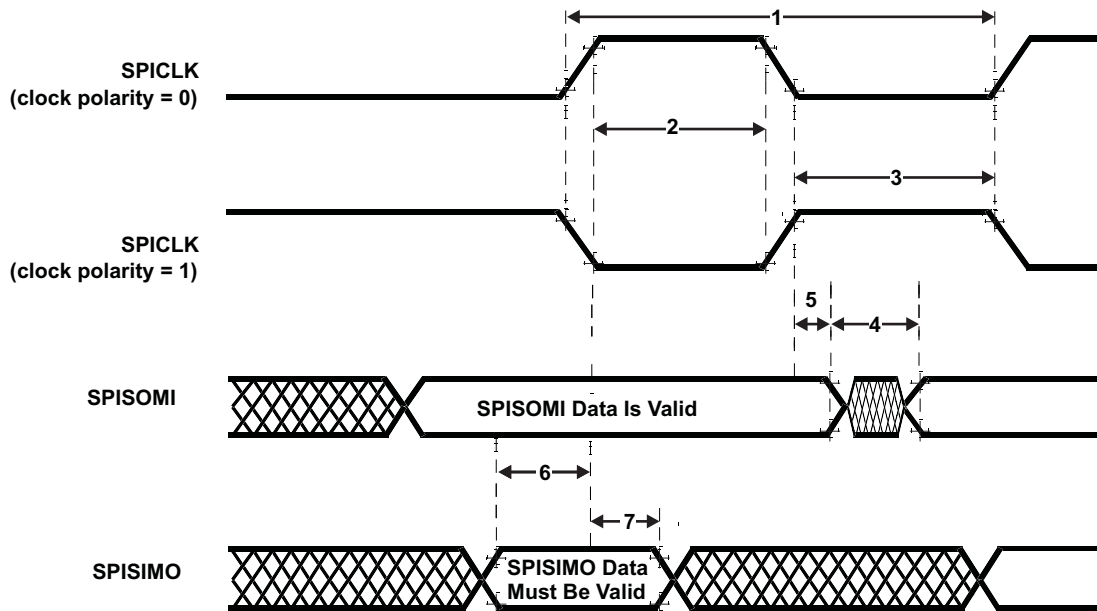

Figure 7-15. SPI Slave Mode External Timing (CLOCK PHASE = 1)

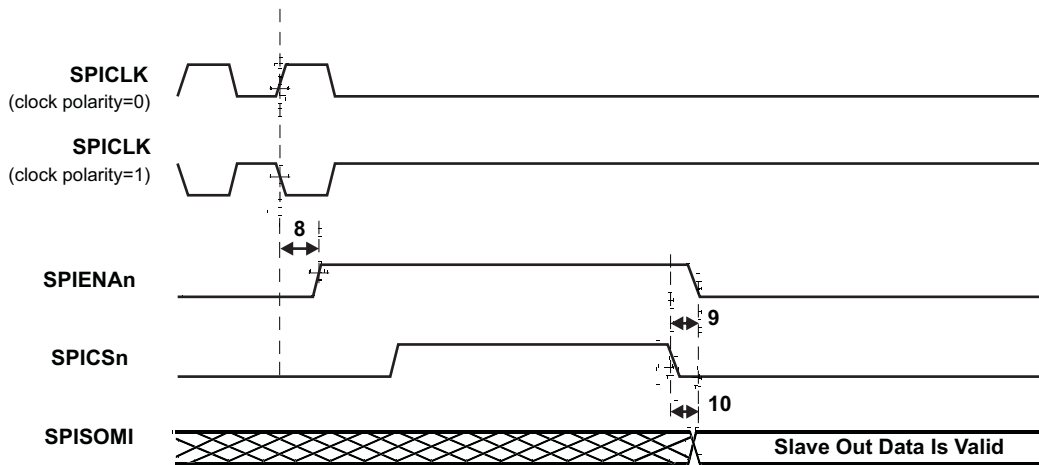

Figure 7-16. SPI Slave Mode Enable Timing (CLOCK PHASE = 1)

7.10 Ethernet Media Access Controller

The Ethernet Media Access Controller (EMAC) provides an efficient interface between the CPU and the network. The EMAC supports both 10Base-T and 100Base-TX, or 10 Mbits/second (Mbps) and 100 Mbps in either half- or full-duplex mode, with hardware flow control and quality of service (QoS) support.

The EMAC controls the flow of packet data from the RM4x device to the PHY. The MDIO module controls PHY configuration and status monitoring.

Both the EMAC and the MDIO modules interface to the RM4x device through a custom interface that allows efficient data transmission and reception. This custom interface is referred to as the EMAC control module, and is considered integral to the EMAC/MDIO peripheral. The control module is also used to multiplex and control interrupts.

7.10.1 Ethernet MII Electrical and Timing Specifications

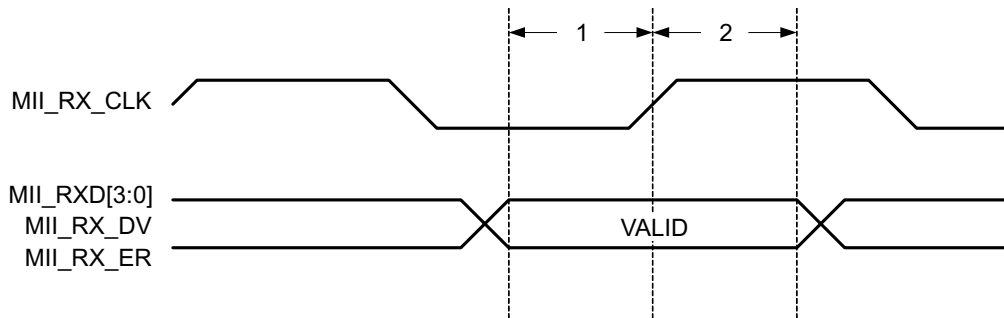

Figure 7-17. MII Receive Timing

Table 7-26. Timing Requirements for EMAC MII Receive

NO.			MIN	MAX	UNIT
1	$t_{su}(MIIRXD - MIIRXCLKH)$	Setup time, MII_RXD[3:0] before MII_RX_CLK rising edge	8		ns
	$t_{su}(MIIRXDV - MIIRXCLKH)$	Setup time, MII_RX_DV before MII_RX_CLK rising edge	8		ns
	$t_{su}(MIIRXER - MIIRXCLKH)$	Setup time, MII_RX_ER before MII_RX_CLK rising edge	8		ns
2	$t_h(MIIRXCLKH - MIIRXD)$	Hold time, MII_RXD[3:0] valid after MII_RX_CLK rising edge	8		ns
	$t_h(MIIRXCLKH - MIIRXDV)$	Hold time, MII_RX_DV valid after MII_RX_CLK rising edge	8		ns
	$t_h(MIIRXCLKH - MIIRXER)$	Hold time, MII_RX_ER valid after MII_RX_CLK rising edge	8		ns

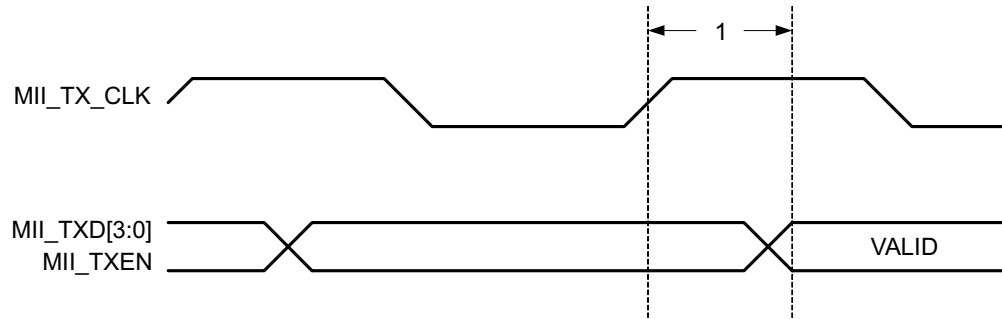

Figure 7-18. MII Transmit Timing

Table 7-27. Switching Characteristics Over Recommended Operating Conditions for EMAC MII Transmit

NO.	PARAMETER	MIN	MAX	UNIT
1	$t_d(\text{MIIRXCLKH} - \text{MIITXD})$ Delay time, MII_TX_CLK rising edge to MII_TXD[3:0] valid	5	25	ns
	$t_d(\text{MIIRXCLKH} - \text{MIITXEN})$ Delay time, MII_TX_CLK rising edge to MII_TXEN valid	5	25	ns

7.10.2 Ethernet RMI Electrical and Timing Specifications

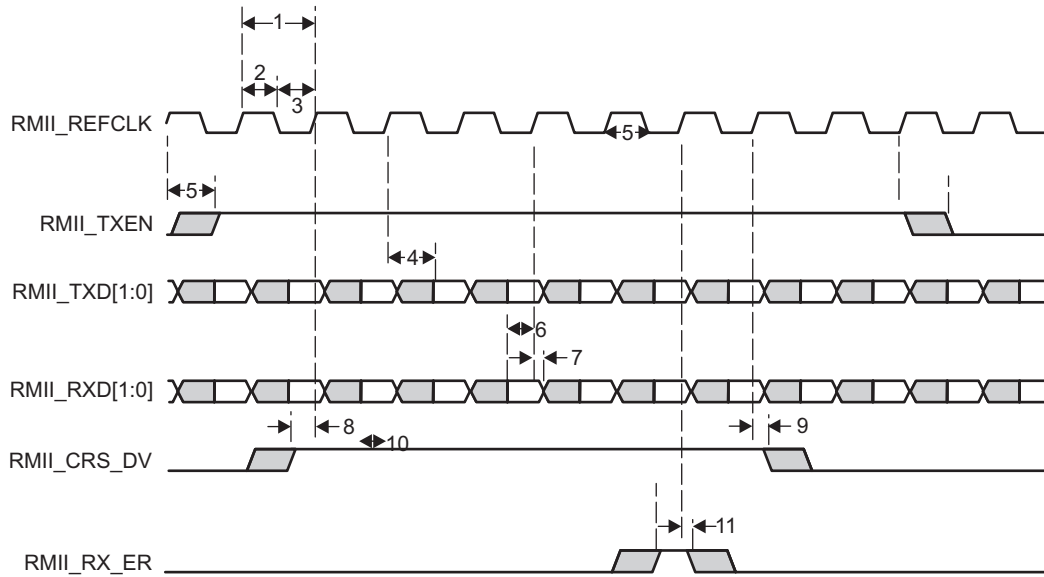

Figure 7-19. RMI Timing Diagram

Table 7-28. Timing Requirements for EMAC RMI Receive and RMII_REFCLK

NO.	PARAMETER	DESCRIPTION	MIN	NOM	MAX	UNIT
1	$t_c(\text{REFCLK})$	Cycle time, RMII_REFCLK		20		ns
2	$t_w(\text{REFCLKH})$	Pulse width, RMII_REFCLK high	7		13	ns
3	$t_w(\text{REFCLKL})$	Pulse width, RMII_REFCLK low	7		13	ns
6	$t_{su}(\text{RXD-REFCLK})$	Input setup time, RMII_RXD[1:0] valid before RMII_REFCLK high	4			ns
7	$t_h(\text{REFCLK-RXD})$	Input hold time, RMII_RXD[1:0] valid after RMII_REFCLK high	2			ns
8	$t_{su}(\text{CRSDV-REFCLK})$	Input setup time, RMII_CRSDV valid before RMII_REFCLK high	4			ns
9	$t_h(\text{REFCLK-CRSDV})$	Input hold time, RMII_CRSDV valid after RMII_REFCLK high	2			ns
10	$t_{su}(\text{RXER-REFCLK})$	Input setup time, RMII_RX_ER valid before RMII_REFCLK high	4			ns
11	$t_h(\text{REFCLK-RXER})$	Input hold time, RMII_RX_ER valid after RMII_REFCLK high	2			ns

Table 7-29. Switching Characteristics Over Recommended Operating Conditions for EMAC RMI Transmit

NO.	PARAMETER	DESCRIPTION	MIN	MAX	UNIT
4	$t_d(\text{REFCLK-TXD})$	Output delay time, RMII_REFCLK high to RMII_TXD[1:0] valid	2		ns
5	$t_d(\text{REFCLK-TXEN})$	Output delay time, RMII_REFCLK high to RMII_TXEN valid	2		ns

7.10.3 Management Data Input/Output (MDIO) Electrical and Timing Specifications

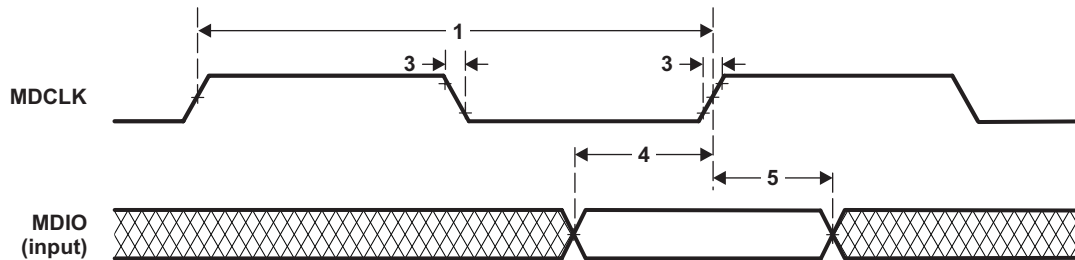

Figure 7-20. MDIO Input Timing

Table 7-30. Timing Requirements for MDIO Input

NO.			MIN	MAX	UNIT
1	$t_c(\text{MDCLK})$	Cycle time, MDCLK	400	-	ns
2	$t_w(\text{MDCLK})$	Pulse duration, MDCLK high or low	180	-	ns
3	$t_t(\text{MDCLK})$	Transition time, MDCLK	-	5	ns
4	$t_{su}(\text{MDIO-MDCLKH})$	Setup time, MDIO data input valid before MDCLK High	33 ⁽¹⁾	-	ns
5	$t_h(\text{MDCLKH-MDIO})$	Hold time, MDIO data input valid after MDCLK High	10	-	ns

(1) This is a discrepancy to IEEE 802.3, but is compatible with many PHY devices.

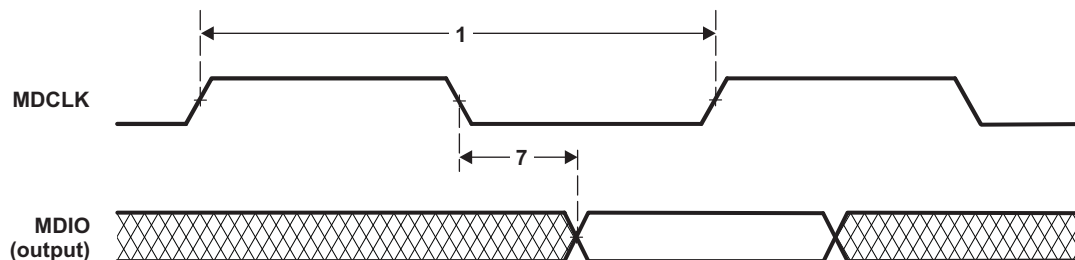

Figure 7-21. MDIO Output Timing

Table 7-31. MDIO Output Timing Requirements

NO.			MIN	MAX	UNIT
1	$t_c(\text{MDCLK})$	Cycle time, MDCLK	400	-	ns
7	$t_d(\text{MDCLKL-MDIO})$	Delay time, MDCLK low to MDIO data output valid	-7	100	ns

7.11 Universal Serial Bus (USB) Host and Device Controllers

7.11.1 Features

This device provides several varieties of USB functionality, including:

- One full-speed USB device port compatible with the USB Specification Revision 2.0 and USB Specification Revision 1.1
- Two USB host ports compatible with USB Specification Revision 2.0, which is based on the OHCI Specification For USB Release 1.0.

7.11.2 Electrical and Timing Specifications

Table 7-32. Full-Speed USB Interface Timing Requirements⁽¹⁾

NO.			MIN	MAX	UNIT
FSU20	$t_{d(VPL, VML)}$	Host time duration, USBx.VP and USBx.VM low together during transition ⁽²⁾		15	ns
		Device time duration, USBx.VP and USBx.VM low together during transition		15	
FSU21	$t_{d(VPH, VMH)}$	Host time duration, USBx.VP and USBx.VM high together during transition ⁽²⁾		15	ns
		Device time duration, USBx.VP and USBx.VM high together during transition		15	

(1) The capacitive loading is equivalent to 15 pF

(2) Applies to both host ports, USB1 and USB2

Table 7-33. Full-Speed USB Interface Switching Characteristics⁽¹⁾

NO.	PARAMETER		MIN	MAX	UNIT
FSU15	$t_{d(TXENL-DATV)}$	Host delay time USBx.TXEN active to USBx.TXDAT valid ⁽²⁾	-2.1	2.2	ns
		Device delay time USBx.TXEN active to USBx.TXDAT valid	0.6	7	
FSU16	$t_{d(TXENL-SE0V)}$	Host delay time USBx.TXEN active to USBx.TXSE0 valid ⁽²⁾	-2.0	2.5	ns
		Device delay time USBx.TXEN active to USBx.TXSE0 valid	-1.9	1.0	
FSU17	$t_{s(DAT-SE0)}$	Host skew between USBx.TXDAT and USBx.TXSE0 transition ⁽²⁾	0	1.7	ns
		Device skew between USBx.TXDAT and USBx.TXSE0 transition	0	7.6	
FSU18	$t_{d(TXENH-DATI)}$	Host delay time USBx.TXEN inactive to USBx.TXDAT invalid ⁽²⁾	-2.2	1.8	ns
		Device delay time USBx.TXEN inactive to USBx.TXDAT invalid	0.8	7.1	
FSU19	$t_{d(TXENH-SE0I)}$	Host delay time USBx.TXEN inactive to USBx.TXSE0 invalid ⁽²⁾	-2.1	1.8	ns
		Device delay time USBx.TXEN inactive to USBx.TXSE0 invalid	-1.9	1.1	

(1) The capacitive loading is equivalent to 15 pF

(2) Applies to both host ports, USB1 and USB2

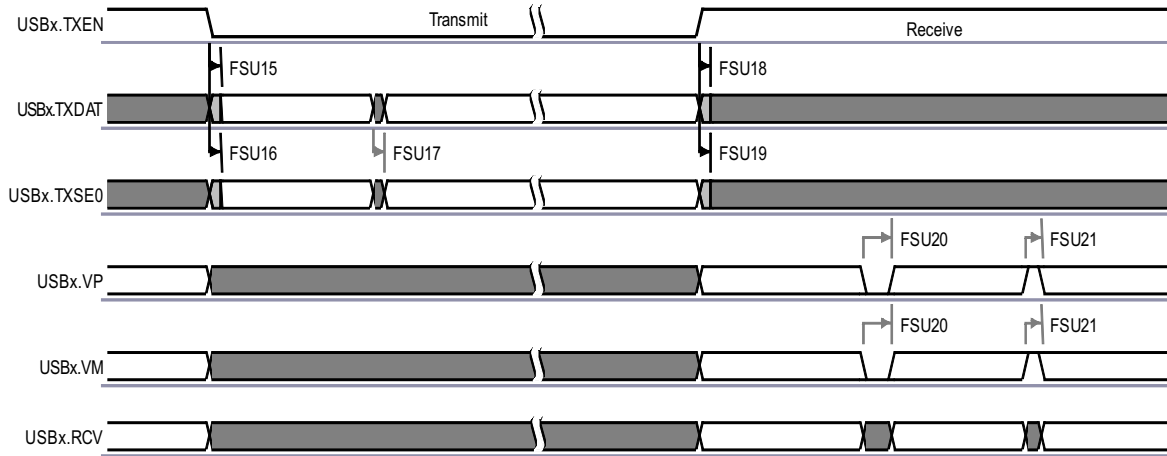

Figure 7-22. Full-Speed USB Interface – Transmit and Receive Modes

8 Device and Documentation Support

8.1 Device Support

8.1.1 Development Support

Texas Instruments (TI) offers an extensive line of development tools for the TMS570LSxRM48Lx family of MCUs, including tools to evaluate the performance of the processors, generate code, develop algorithm implementations, and fully integrate and debug software and hardware modules.

The following products support development:

Software Development Tools

- Code Composer Studio™ (CCS) Integrated Development Environment (IDE)–
 - C/C++ Compiler
 - Code generation tools
 - Assembler/Linker
 - FPU Optimized Libraries
- Application algorithms
- Sample applications code

Hardware Development Tools

- Development and evaluation boards
- JTAG-based emulators - XDS510™ class, XDS560™ emulator, XDS100v2, XDS110, XDS200
- Flash programming tools

For a complete listing of development-support tools, visit the Texas Instruments website at www.ti.com.

8.1.2 Device Nomenclature

To designate the stages in the product development cycle, TI assigns prefixes to the part numbers of all MCU devices. Each MCU commercial family member has one of three prefixes: X, P, or NULL [blank] (for example, xRM48L952). These prefixes represent evolutionary stages of product development from engineering prototypes (X) through fully qualified production devices (NULL[blank]).

Device development evolutionary flow:

X	Experimental device that is not necessarily representative of the final device's electrical specifications.
P	Final silicon die that conforms to the device's electrical specifications but has not completed quality and reliability verification.
NULL	Fully-qualified production device.

X and P devices are shipped against the following disclaimer:

"Developmental product is intended for internal evaluation purposes."

Production devices have been characterized fully, and the quality and reliability of the device have been demonstrated fully. TI's standard warranty applies.

Predictions show that prototype devices (X or P) have a greater failure rate than the standard production devices. Texas Instruments recommends that these devices not be used in any production system because their expected end-use failure rate still is undefined. Only qualified production devices are to be used.

Figure 8-1 shows the numbering and symbol nomenclature for the RM48L952 .

For additional information on the device nomenclature markings, see the device-specific silicon errata document listed in [Section 8.2.1](#), *Related Documentation from Texas Instruments*.

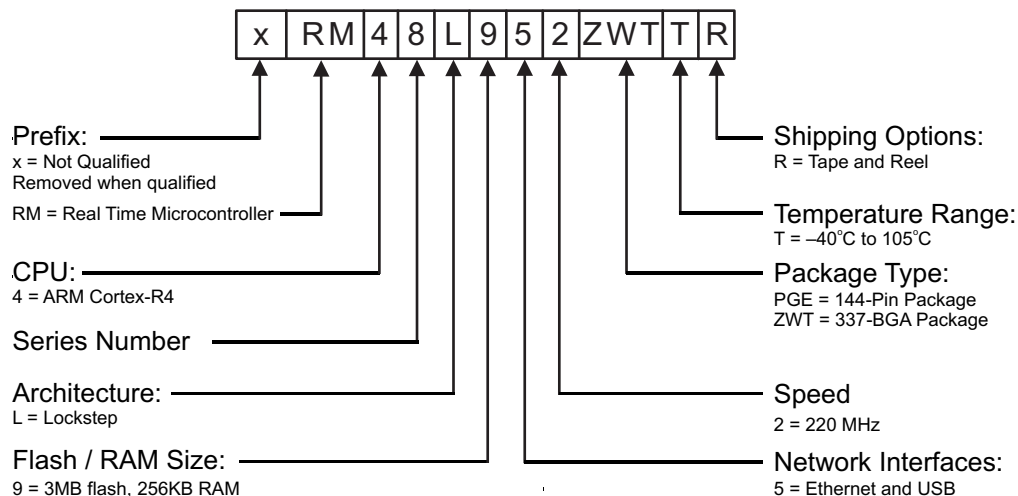

Figure 8-1. RM48x Device Numbering Conventions

8.2 Documentation Support

8.2.1 Related Documentation from Texas Instruments

The following documents describe the *RM48L952* microcontroller..

[SPNU503](#) *RM48x 16/32-Bit RISC Flash Microcontroller Technical Reference Manual* details the integration, the environment, the functional description, and the programming models for each peripheral and subsystem in the device.

[SPNZ196](#) *RM48x Microcontroller, Silicon Revision C, Silicon Errata* describes the usage notes and known exceptions to the functional specifications for the device silicon revision C.

[SPNZ223](#) *RM48x Microcontroller, Silicon Revision D, Silicon Errata* describes the usage notes and known exceptions to the functional specifications for the device silicon revision D.

[SPNA207](#) *Calculating Equivalent Power-on-Hours for Hercules™ Safety MCUs* details how to use the spreadsheet to calculate the aging effect of temperature on Texas Instruments Hercules Safety MCUs.

8.3 Community Resources

The following links connect to TI community resources. Linked contents are provided "AS IS" by the respective contributors. They do not constitute TI specifications and do not necessarily reflect TI's views; see TI's [Terms of Use](#).

[TI E2E™ Online Community](#) *TI's Engineer-to-Engineer (E2E) Community*. Created to foster collaboration among engineers. At [e2e.ti.com](#), you can ask questions, share knowledge, explore ideas and help solve problems with fellow engineers.

[TI Embedded Processors Wiki](#) *Texas Instruments Embedded Processors Wiki*. Established to help developers get started with Embedded Processors from Texas Instruments and to foster innovation and growth of general knowledge about the hardware and software surrounding these devices.

8.4 Trademarks

Code Composer Studio, XDS510, XDS560, E2E are trademarks of Texas Instruments.

CoreSight is a trademark of ARM Limited.

ARM, Cortex are registered trademarks of ARM Limited (or its subsidiaries) in the EU and/or elsewhere.

All rights reserved.

I²C-bus is a trademark of NXP Semiconductors N. V.

All other trademarks are the property of their respective owners.

8.5 Electrostatic Discharge Caution



This integrated circuit can be damaged by ESD. Texas Instruments recommends that all integrated circuits be handled with appropriate precautions. Failure to observe proper handling and installation procedures can cause damage.

ESD damage can range from subtle performance degradation to complete device failure. Precision integrated circuits may be more susceptible to damage because very small parametric changes could cause the device not to meet its published specifications.

8.6 Glossary

[SLYZ022](#) — *TI Glossary*.

This glossary lists and explains terms, acronyms, and definitions.

8.7 Device Identification Code Register

The device identification code register identifies several aspects of the device including the silicon version. The details of the device identification code register are shown in [Table 8-1](#). The device identification code register value for this device is:

- Rev A = 0x802AAD05
- Rev B = 0x802AAD15
- Rev C = 0x802AAD1D
- Rev D = 0x802AAD25

Figure 8-2. Device ID Bit Allocation Register

31	30	29	28	27	26	25	24	23	22	21	20	19	18	17	16
CP-15	UNIQUE ID														TECH
R-1	R-00000000010101														R-0
15	14	13	12	11	10	9	8	7	6	5	4	3	2	1	0
TECH		I/O VOLT AGE	PERIPH PARITY	FLASH ECC	RAM ECC	VERSION						1	0	1	
R-101		R-0	R-1	R-10	R-1	R-00000						R-1	R-0	R-1	

LEGEND: R/W = Read/Write; R = Read only; -n = value after reset

Table 8-1. Device ID Bit Allocation Register Field Descriptions

BIT	FIELD	VALUE	DESCRIPTION
31	CP15	1	Indicates the presence of coprocessor 15 CP15 present
30-17	UNIQUE ID	10101	Silicon version (revision) bits. This bit field holds a unique number for a dedicated device configuration (die).
16-13	TECH	0101	Process technology on which the device is manufactured. F021
12	I/O VOLTAGE	0	I/O voltage of the device. I/O are 3.3 V
11	PERIPHERAL PARITY	1	Peripheral Parity Parity on peripheral memories
10-9	FLASH ECC	10	Flash ECC Program memory with ECC
8	RAM ECC	1	Indicates if RAM memory ECC is present. ECC implemented
7-3	REVISION		Revision of the device.
2-0	101		The platform family ID is always 0b101

8.8 Die Identification Registers

The two die ID registers at addresses 0xFFFFF7C and 0xFFFFF80 form a 64-bit die ID with the information as shown in [Table 8-2](#).

Table 8-2. Die-ID Registers

ITEM	NUMBER OF BITS	BIT LOCATION
X Coord. on Wafer	12	0xFFFFF7C[11:0]
Y Coord. on Wafer	12	0xFFFFF7C[23:12]
Wafer #	8	0xFFFFF7C[31:24]
Lot #	24	0xFFFFF80[23:0]
Reserved	8	0xFFFFF80[31:24]

8.9 Module Certifications

The following communications modules have received certification of adherence to a standard.

8.9.1 DCAN Certification

Testhouse
 C&S group GmbH
 Am Exer 19b
 D-38302 Wolfenbuettel
 Phone: +49 5331/90 555-0
 Fax: +49 5331/90 555-110





Authentication

on CAN Conformance

Texas Instruments

P10_0294_021_CAN_DL_Test_Authentication_r01.doc
 Date of Approval: 2011-Feb-08

C&S is worldwide recognized as a neutral expert in testing of communication systems such as CAN Transceiver, CAN, CAN Software Drivers, (CAN) Network Management, FlexRay and LIN.
 Herewith C&S group is proud to confirm that the followings tests on the subsequently specified device implementations have been performed by C&S resulting in the findings given below:

C&S Conformance Test Results

Manufacturer	Texas Instruments
Component/Part Number	TMSx70 x021 Microcontroller Family, DCAN Core Release 0xA3170504, 980 A2C0007940000 X470MUF C63C1 P80576 24 YFB-08A9X6W
Date of Tests	February 2011
Version of Test Specification	CAN Conformance Test <ol style="list-style-type: none"> 1 ISO CAN Conformance Tests according to "ISO 16845:2004 Road vehicles - Controller area network (CAN) - Conformance test plan" and C&S enhancement/ corrections according to "CAN CONFORMANCE TESTING Test Specification C&S Version 2.0 RC" 2 C&S Register Functionality Tests according to "C&S Register Functionality Test Specification V2.0" 3 C&S Robustness Tests according to "C&S Robustness Test Specification V1.4"
Corresponding Test Report	P10_0294_020_CAN_DL_Test_report_r01
1 ISO CAN conformance tests	Pass
2 C&S Register Functionality tests	Pass
3 C&S Robustness tests	Pass
• Further Observations	None

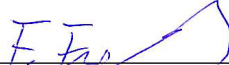

 Frank Fischer, CTO



 Lothar Kukla, Project Manager

Quote No. P10_0294 R01

Figure 8-3. DCAN Certification

8.9.2 LIN Certification

8.9.2.1 LIN Master Mode

ihr

AUTOMOTIVE
Engineering
Services & Products

lin
LOCAL INTERCONNECT NETWORK

DAKKS
Deutsche
Akkreditierungsstelle
D-PL-17201-01-01

Accredited test lab by DAKKS GmbH according DIN ISO/IEC 17025.
The accreditation is valid for all test methods stated in the certificate.

Test Summary

for
LIN 2.1 Conformance Test - Master

Client / Manufacturer: **Texas Instruments**
Automotive Applications
12500 TI Boulevard
75243 DALLAS, TEXAS
UNITED STATES OF AMERICA

Implementation Under Test: **Microcontroller TMS570LS3137**

Part Number: **LIN Master Mode**

Revision: SW: : 2013-05-31_IHR_LIN

Test Sample Marking: TMX570LS 3137 CZWTQQ1 YFC-2AAQ32W

Test Board: Gladiator 337 SN# 58 rev. B

Performed Tests: **LIN OSI Layer 2 – Data Link Layer**
Node Configuration / Network Management

Specification References: **LIN Conformance Test Specification, 10-Oct-2008**
for the LIN Specification Package Revision 2.1 , 24-Nov-2006

Result / Status: **The device has *passed* the test.**

Version / Date: 1.0 / 13-May-2013

Document Number: Test Summary_DLL21_Master_20121130_130513_TMS570LS_V1.0.doc

ihr Reference: 20121130

This test summary don't represent a complete test report according the LIN consortium.
It contains 7 pages and shall not be reproduced except in full without written approval of the *ihr* Test Center. All performed test results concerns the above mentioned IUT revision only.

ihr GmbH
Airport Boulevard B 210
D 77836 Rheinmünster
Tel.: +49 (0) 7229-18475-0
Fax: +49 (0) 7229-18475-11

Bank: Volksbank Bühl
Konto: 1376209
BLZ: 66291400
UST-Id-Nr. DE177221429

Geschäftsführer: Jörg Holzberg
Gerichtsstand: Bühl
Handelsreg.:Baden-Baden HRB908BH
eMail: info@ihr.de
Internet: www.ihr.de

Figure 8-4. LIN Certification - Master Mode

8.9.2.2 LIN Slave Mode - Fixed Baud Rate

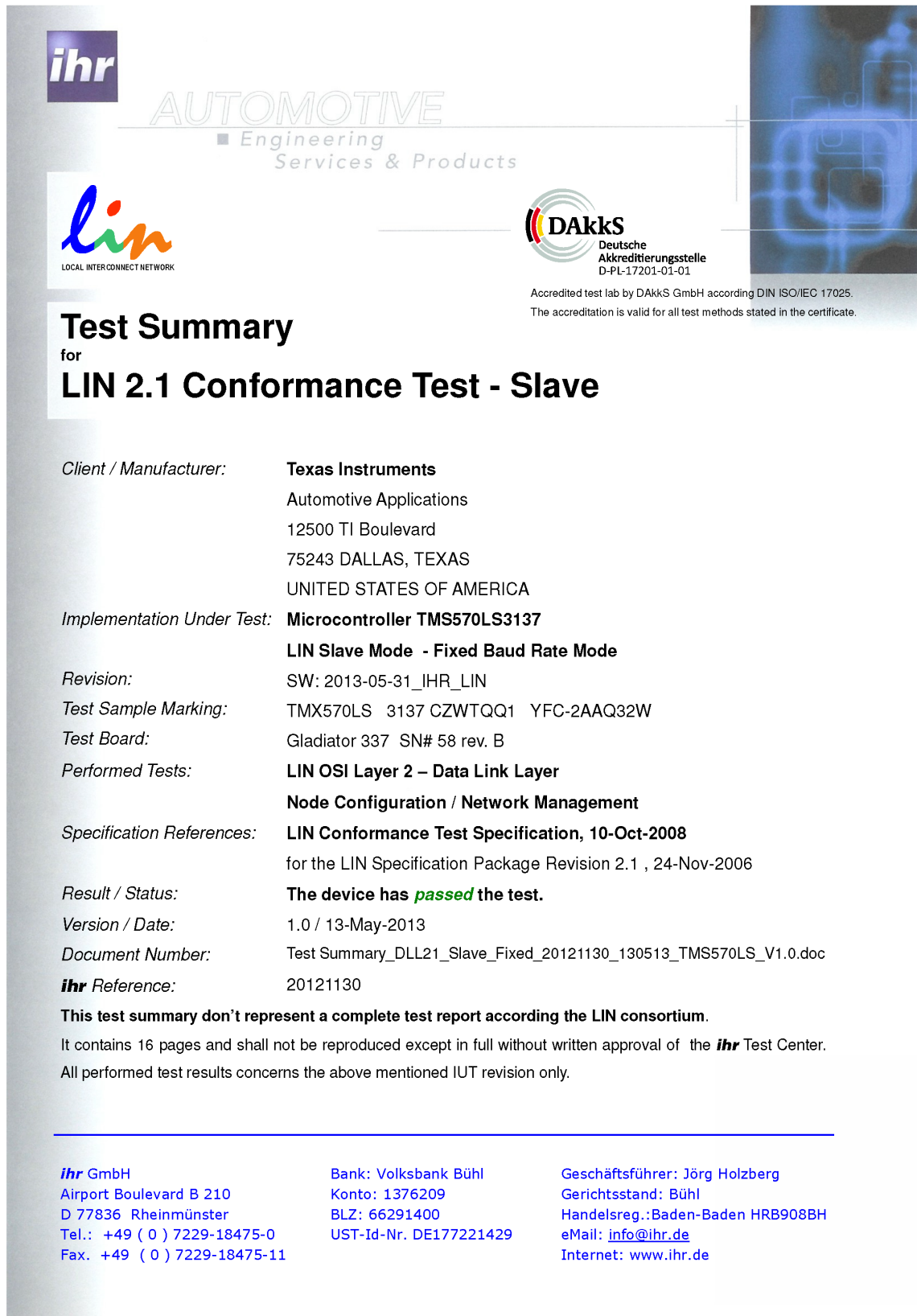

ihr
AUTOMOTIVE
Engineering
Services & Products

lin
LOCAL INTERCONNECT NETWORK

DAkks
Deutsche
Akkreditierungsstelle
D-PL-17201-01-01

Accredited test lab by DAkks GmbH according DIN ISO/IEC 17025.
The accreditation is valid for all test methods stated in the certificate.

Test Summary for LIN 2.1 Conformance Test - Slave

Client / Manufacturer: Texas Instruments
Automotive Applications
12500 TI Boulevard
75243 DALLAS, TEXAS
UNITED STATES OF AMERICA

Implementation Under Test: Microcontroller TMS570LS3137
LIN Slave Mode - Fixed Baud Rate Mode

Revision: SW: 2013-05-31_IHR_LIN

Test Sample Marking: TMX570LS 3137 CZWTQQ1 YFC-2AAQ32W

Test Board: Gladiator 337 SN# 58 rev. B

Performed Tests: LIN OSI Layer 2 – Data Link Layer
Node Configuration / Network Management

Specification References: LIN Conformance Test Specification, 10-Oct-2008
for the LIN Specification Package Revision 2.1 , 24-Nov-2006

Result / Status: The device has **passed** the test.

Version / Date: 1.0 / 13-May-2013

Document Number: Test Summary_DLL21_Slave_Fixed_20121130_130513_TMS570LS_V1.0.doc

ihr Reference: 20121130

This test summary don't represent a complete test report according the LIN consortium.
It contains 16 pages and shall not be reproduced except in full without written approval of the **ihr** Test Center.
All performed test results concerns the above mentioned IUT revision only.

ihr GmbH
Airport Boulevard B 210
D 77836 Rheinmünster
Tel.: +49 (0) 7229-18475-0
Fax. +49 (0) 7229-18475-11

Bank: Volksbank Bühl
Konto: 1376209
BLZ: 66291400
UST-Id-Nr. DE177221429

Geschäftsführer: Jörg Holzberg
Gerichtsstand: Bühl
Handelsreg.:Baden-Baden HRB908BH
eMail: info@ihr.de
Internet: www.ihr.de

Figure 8-5. LIN Certification - Slave Mode - Fixed Baud Rate

8.9.2.3 LIN Slave Mode - Adaptive Baud Rate

Test Summary
for
LIN 2.1 Conformance Test - Slave

Client / Manufacturer: **Texas Instruments**
Automotive Applications
12500 TI Boulevard
75243 DALLAS, TEXAS
UNITED STATES OF AMERICA

Implementation Under Test: **Microcontroller TMS570LS3137**
LIN Slave Mode - Adaptive Baud Rate Mode

Revision: SW: 2013-05-31_IHR_LIN

Test Sample Marking: TMX570LS 3137 CZWTQQ1 YFC-2AAQ32W

Test Board: Gladiator 337 SN# 58 rev. B

Performed Tests: **LIN OSI Layer 2 – Data Link Layer**
Node Configuration / Network Management

Specification References: **LIN Conformance Test Specification, 10-Oct-2008**
for the LIN Specification Package Revision 2.1 , 24-Nov-2006

Result / Status: **The device has *passed* the test.**

Version / Date: 1.0 / 13-May-2013

Document Number: Test Summary_DLL21_Slave_Adapt_TI_TMS570LS_130513_V1.0.doc

ihr Reference: 20121130

This test summary don't represent a complete test report according the LIN consortium.
It contains 16 pages and shall not be reproduced except in full without written approval of the **ihr** Test Center.
All performed test results concerns the above mentioned IUT revision only.

ihr GmbH
Airport Boulevard B 210
D 77836 Rheinmünster
Tel.: +49 (0) 7229-18475-0
Fax. +49 (0) 7229-18475-11

Bank: Volksbank Bühl
Konto: 1376209
BLZ: 66291400
UST-Id-Nr. DE177221429

Geschäftsführer: Jörg Holzberg
Gerichtsstand: Bühl
Handelsreg.:Baden-Baden HRB908BH
eMail: info@ihr.de
Internet: www.ihr.de

Figure 8-6. LIN Certification - Slave Mode - Adaptive Baud Rate

9 Mechanical Packaging and Orderable Information

9.1 Packaging Information

The following pages include mechanical packaging and orderable information. This information is the most current data available for the designated devices. This data is subject to change without notice and without revision of this document. For browser-based versions of this data sheet, refer to the left-hand navigation.

PACKAGING INFORMATION

Orderable Device	Status (1)	Package Type	Package Drawing	Pins	Package Qty	Eco Plan (2)	Lead/Ball Finish (6)	MSL Peak Temp (3)	Op Temp (°C)	Device Marking (4/5)	Samples
RM48L952PGET	ACTIVE	LQFP	PGE	144	60	Green (RoHS & no Sb/Br)	CU NIPDAU	Level-3-260C-168 HR	-40 to 105	RM48 L952PGET	Samples
RM48L952ZWTT	ACTIVE	NFBGA	ZWT	337	90	Green (RoHS & no Sb/Br)	SNAGCU	Level-3-260C-168 HR	-40 to 105	RM48 L952ZWTT	Samples

(1) The marketing status values are defined as follows:

ACTIVE: Product device recommended for new designs.

LIFEBUY: TI has announced that the device will be discontinued, and a lifetime-buy period is in effect.

NRND: Not recommended for new designs. Device is in production to support existing customers, but TI does not recommend using this part in a new design.

PREVIEW: Device has been announced but is not in production. Samples may or may not be available.

OBSOLETE: TI has discontinued the production of the device.

(2) Eco Plan - The planned eco-friendly classification: Pb-Free (RoHS), Pb-Free (RoHS Exempt), or Green (RoHS & no Sb/Br) - please check <http://www.ti.com/productcontent> for the latest availability information and additional product content details.

TBD: The Pb-Free/Green conversion plan has not been defined.

Pb-Free (RoHS): TI's terms "Lead-Free" or "Pb-Free" mean semiconductor products that are compatible with the current RoHS requirements for all 6 substances, including the requirement that lead not exceed 0.1% by weight in homogeneous materials. Where designed to be soldered at high temperatures, TI Pb-Free products are suitable for use in specified lead-free processes.

Pb-Free (RoHS Exempt): This component has a RoHS exemption for either 1) lead-based flip-chip solder bumps used between the die and package, or 2) lead-based die adhesive used between the die and leadframe. The component is otherwise considered Pb-Free (RoHS compatible) as defined above.

Green (RoHS & no Sb/Br): TI defines "Green" to mean Pb-Free (RoHS compatible), and free of Bromine (Br) and Antimony (Sb) based flame retardants (Br or Sb do not exceed 0.1% by weight in homogeneous material)

(3) MSL, Peak Temp. - The Moisture Sensitivity Level rating according to the JEDEC industry standard classifications, and peak solder temperature.

(4) There may be additional marking, which relates to the logo, the lot trace code information, or the environmental category on the device.

(5) Multiple Device Markings will be inside parentheses. Only one Device Marking contained in parentheses and separated by a "~" will appear on a device. If a line is indented then it is a continuation of the previous line and the two combined represent the entire Device Marking for that device.

(6) Lead/Ball Finish - Orderable Devices may have multiple material finish options. Finish options are separated by a vertical ruled line. Lead/Ball Finish values may wrap to two lines if the finish value exceeds the maximum column width.

Important Information and Disclaimer: The information provided on this page represents TI's knowledge and belief as of the date that it is provided. TI bases its knowledge and belief on information provided by third parties, and makes no representation or warranty as to the accuracy of such information. Efforts are underway to better integrate information from third parties. TI has taken and continues to take reasonable steps to provide representative and accurate information but may not have conducted destructive testing or chemical analysis on incoming materials and chemicals. TI and TI suppliers consider certain information to be proprietary, and thus CAS numbers and other limited information may not be available for release.

In no event shall TI's liability arising out of such information exceed the total purchase price of the TI part(s) at issue in this document sold by TI to Customer on an annual basis.

ZWT (S-PBGA-N337)

PLASTIC BALL GRID ARRAY

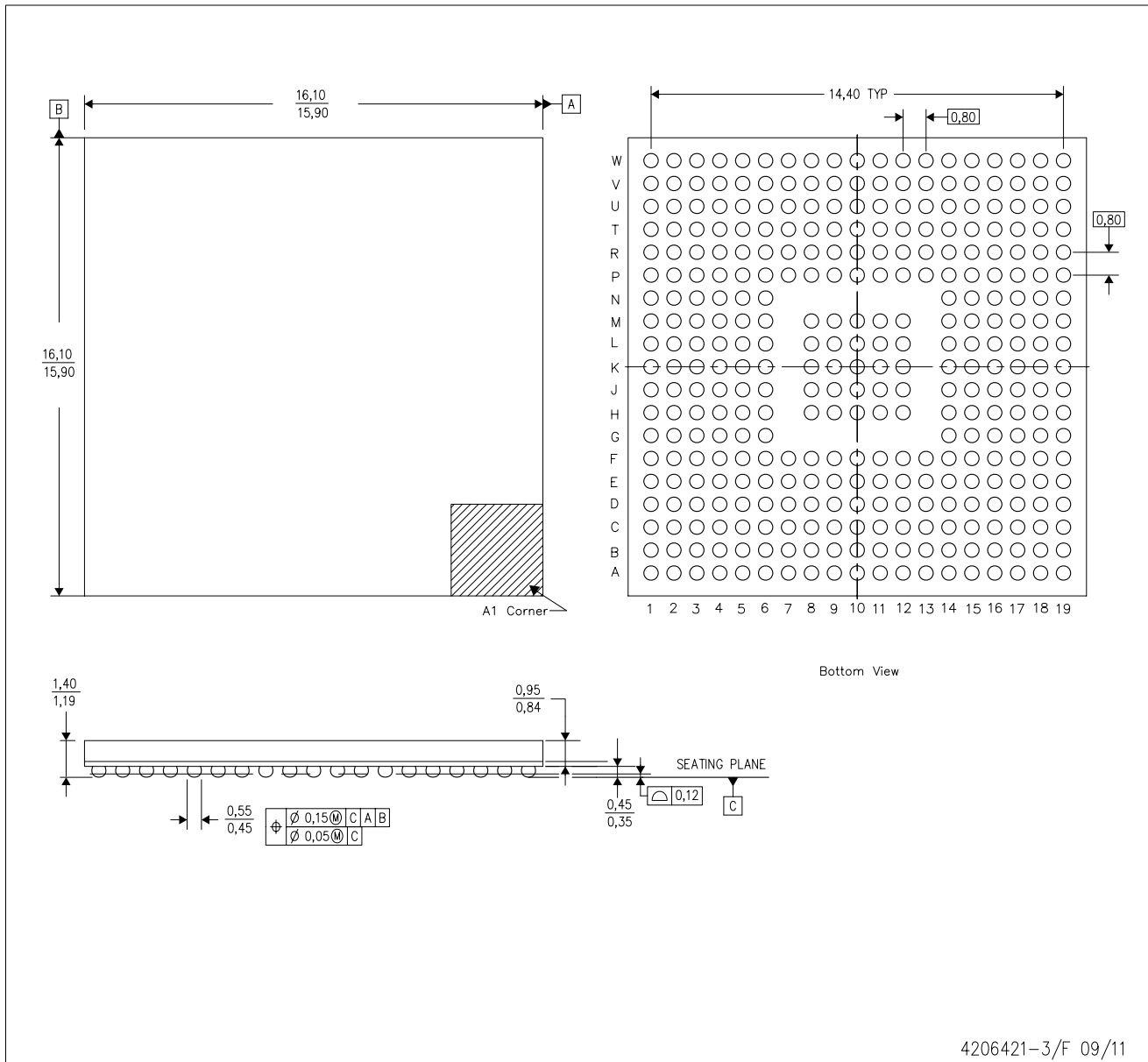

- NOTES:
- A. All linear dimensions are in millimeters. Dimensioning and tolerancing per ASME Y14.5M-1994.
 - B. This drawing is subject to change without notice.
 - C. This is a Pb-free solder ball design.
 - D. Falls within JEDEC MO-275.

PGE (S-PQFP-G144)

PLASTIC QUAD FLATPACK

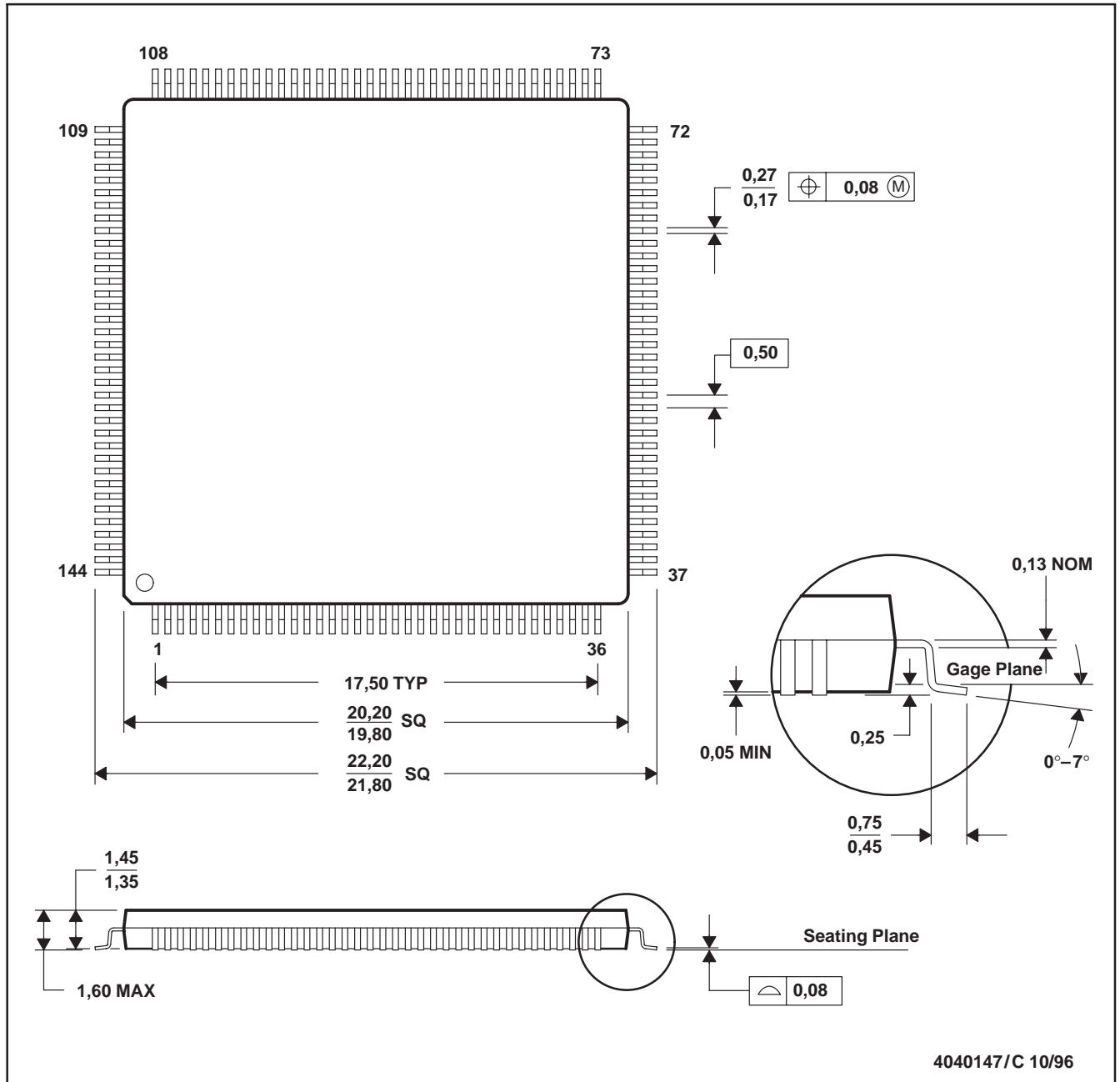

- NOTES: A. All linear dimensions are in millimeters.
 B. This drawing is subject to change without notice.
 C. Falls within JEDEC MS-026

IMPORTANT NOTICE

Texas Instruments Incorporated and its subsidiaries (TI) reserve the right to make corrections, enhancements, improvements and other changes to its semiconductor products and services per JESD46, latest issue, and to discontinue any product or service per JESD48, latest issue. Buyers should obtain the latest relevant information before placing orders and should verify that such information is current and complete. All semiconductor products (also referred to herein as "components") are sold subject to TI's terms and conditions of sale supplied at the time of order acknowledgment.

TI warrants performance of its components to the specifications applicable at the time of sale, in accordance with the warranty in TI's terms and conditions of sale of semiconductor products. Testing and other quality control techniques are used to the extent TI deems necessary to support this warranty. Except where mandated by applicable law, testing of all parameters of each component is not necessarily performed.

TI assumes no liability for applications assistance or the design of Buyers' products. Buyers are responsible for their products and applications using TI components. To minimize the risks associated with Buyers' products and applications, Buyers should provide adequate design and operating safeguards.

TI does not warrant or represent that any license, either express or implied, is granted under any patent right, copyright, mask work right, or other intellectual property right relating to any combination, machine, or process in which TI components or services are used. Information published by TI regarding third-party products or services does not constitute a license to use such products or services or a warranty or endorsement thereof. Use of such information may require a license from a third party under the patents or other intellectual property of the third party, or a license from TI under the patents or other intellectual property of TI.

Reproduction of significant portions of TI information in TI data books or data sheets is permissible only if reproduction is without alteration and is accompanied by all associated warranties, conditions, limitations, and notices. TI is not responsible or liable for such altered documentation. Information of third parties may be subject to additional restrictions.

Resale of TI components or services with statements different from or beyond the parameters stated by TI for that component or service voids all express and any implied warranties for the associated TI component or service and is an unfair and deceptive business practice. TI is not responsible or liable for any such statements.

Buyer acknowledges and agrees that it is solely responsible for compliance with all legal, regulatory and safety-related requirements concerning its products, and any use of TI components in its applications, notwithstanding any applications-related information or support that may be provided by TI. Buyer represents and agrees that it has all the necessary expertise to create and implement safeguards which anticipate dangerous consequences of failures, monitor failures and their consequences, lessen the likelihood of failures that might cause harm and take appropriate remedial actions. Buyer will fully indemnify TI and its representatives against any damages arising out of the use of any TI components in safety-critical applications.

In some cases, TI components may be promoted specifically to facilitate safety-related applications. With such components, TI's goal is to help enable customers to design and create their own end-product solutions that meet applicable functional safety standards and requirements. Nonetheless, such components are subject to these terms.

No TI components are authorized for use in FDA Class III (or similar life-critical medical equipment) unless authorized officers of the parties have executed a special agreement specifically governing such use.

Only those TI components which TI has specifically designated as military grade or "enhanced plastic" are designed and intended for use in military/aerospace applications or environments. Buyer acknowledges and agrees that any military or aerospace use of TI components which have **not** been so designated is solely at the Buyer's risk, and that Buyer is solely responsible for compliance with all legal and regulatory requirements in connection with such use.

TI has specifically designated certain components as meeting ISO/TS16949 requirements, mainly for automotive use. In any case of use of non-designated products, TI will not be responsible for any failure to meet ISO/TS16949.

Products

Audio	www.ti.com/audio
Amplifiers	amplifier.ti.com
Data Converters	dataconverter.ti.com
DLP® Products	www.dlp.com
DSP	dsp.ti.com
Clocks and Timers	www.ti.com/clocks
Interface	interface.ti.com
Logic	logic.ti.com
Power Mgmt	power.ti.com
Microcontrollers	microcontroller.ti.com
RFID	www.ti-rfid.com
OMAP Applications Processors	www.ti.com/omap
Wireless Connectivity	www.ti.com/wirelessconnectivity

Applications

Automotive and Transportation	www.ti.com/automotive
Communications and Telecom	www.ti.com/communications
Computers and Peripherals	www.ti.com/computers
Consumer Electronics	www.ti.com/consumer-apps
Energy and Lighting	www.ti.com/energy
Industrial	www.ti.com/industrial
Medical	www.ti.com/medical
Security	www.ti.com/security
Space, Avionics and Defense	www.ti.com/space-avionics-defense
Video and Imaging	www.ti.com/video

TI E2E Community

e2e.ti.com