

## TROPO 15W LED DRIVER

### DESCRIPTION

TROPO switch mode power supply technology is designed to generate one constant current output from an AC input, and work with industry standard lighting controls in dimming applications.

### KEY FEATURES

- 120V<sub>AC</sub> or 230V<sub>AC</sub> Input
- Output current availability 0.35A-1.5A.
- Dims with leading and trailing edge dimmers
- Efficiency up to 82%
- 90°C Top case rated
- Compact Encapsulated Assembly
- Active Power Factor Correction
- UL and ENEC Approved
- Long Life
- RoHS Compliant



### APPLICATIONS AND BENEFITS

TROPO is designed for powering LED luminaires with standard lighting controls. The modules operate with:

- Standard Light Switches
- Triac based Incandescent Dimmers (Standard phase – leading edge)
- Electronic Low Voltage Dimmers (Reverse Phase – trailing edge)

The following diagram depicts a typical installation utilizing the TROPO:

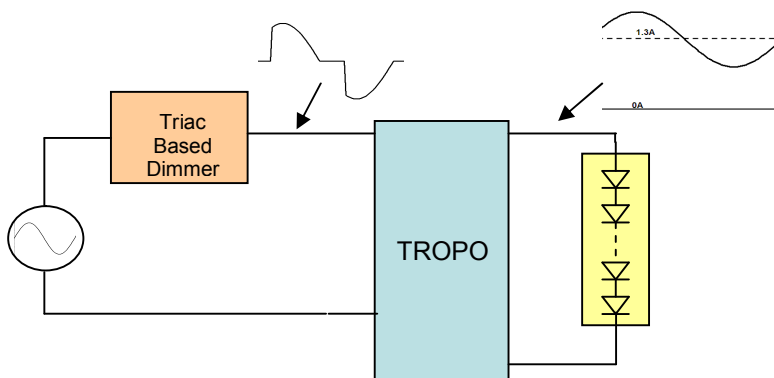

#### Trope's Dimming Options:

- Dimming range down to less than 10% nominal output current
- Output current does not terminate during off time of dimmer
- Output Current up to 1.5A
- Multiple Drivers / LED Assemblies may be connected to a single dimmer
- Facilitates compliance with Energy Star ratings for LED luminaires

**MODEL CODING AND OUTPUT RATINGS**

Low Input Voltage (120V <sub>AC</sub> Only)					
Model Number	Pout Max (W)	Iout (mA)	Vout Min <sup>1</sup> (V <sub>DC</sub> )	Vout Max <sup>1</sup> (V <sub>DC</sub> )	Vout No_Load (V <sub>DC</sub> )
RLDD015L-350	16.8	350	24	48	60
RLDD015L-350H	7.4	350	12	21	37
RLDD015L-350J	11.2	350	18	32	37
RLDD015L-480	6.5	480	10	13.5	24
RLDD015L-600	7.2	600	8	12	16
RLDD015L-700	16.8	700	16	24	35
RLDD015L-800	9.6	800	8	12	16
RLDD015L-900	14.4	900	10	16	25
RLDD015L-900L	10.8	900	8	12	16
RLDD015L-1000	16.0	1000	10	16	25
RLDD015L-1200	15.8	1200	10	13.2	25
RLDD015L-1250	15.0	1250	8	12	16
RLDD015L-1400 <sup>2</sup>	16.1	1400	8	11.5	16
RLDD015L-1500	15.0	1500	5	10	16

High Input Voltage (230V <sub>AC</sub> Only)					
Model Number	Pout Max (W)	Iout (mA)	Vout Min <sup>1</sup> (V <sub>DC</sub> )	Vout Max <sup>1</sup> (V <sub>DC</sub> )	Vout No_Load (V <sub>DC</sub> )
RLDD015H-350	16.8	350	24	48	60
RLDD015H-350H	7.4	350	12	21	37
RLDD015H-350J	11.2	350	18	32	37
RLDD015H-480	6.5	480	10	13.5	24
RLDD015H-600	7.2	600	8	12	16
RLDD015H-700	16.8	700	16	24	35
RLDD015H-800	9.6	800	8	12	16
RLDD015H-900	14.4	900	10	16	25
RLDD015H-900L	10.8	900	8	12	16
RLDD015H-1000	16.0	1000	10	16	25
RLDD015H-1200	15.8	1200	10	13.2	25
RLDD015H-1250	15.0	1250	8	12	16
RLDD015H-1400 <sup>2</sup>	16.1	1400	8	11.5	16
RLDD015H-1500	15.0	1500	5	10	16

**Note 1:** Total LED forward voltage must be within these ratings under all conditions including dimming. Tropro Application Note 2 provides additional technical information.

**Note 2:** Maximum Top case rating for model RLDD15X-1400 is 80°C

**Table 1: Absolute Maximum Driver Ratings**

**INPUT SPECIFICATIONS**

Specification	Test Conditions / Notes	Min.	Nominal	Max.	Units
<b>AC Input Voltage</b>	120V <sub>AC</sub> Rated Models	90	120	135	V <sub>AC</sub>
<b>AC Input Voltage</b>	230V <sub>AC</sub> Rated Models	176	230	265	V <sub>AC</sub>
<b>Input Frequency</b>		47	50/60	63	Hz
<b>Input Current</b>	120V <sub>AC</sub>	-	-	0.17	A
	230V <sub>AC</sub>	-	-	0.09	A
<b>Inrush Current</b>	120V <sub>AC</sub>	Half Value time: 20μs		2.0	Apk
	230V <sub>AC</sub>	Half Value time: 20μs		2.5	Apk
<b>Efficiency</b>	Rated Load	78	-	82	%
<b>Power Factor</b>	120V <sub>AC</sub> Rated Load	0.9	-	-	
	230V <sub>AC</sub> Rated Load; PF is >0.8 for 230VAC Models with output power <10W	0.9	-	-	

**OUTPUT SPECIFICATIONS**

Specification	Test Conditions / Notes	Min.	Nominal	Max.	Units
<b>Output Power Rating</b>	check Model Coding and Output Ratings table	6.5	-	16.8	W
<b>Output Voltage</b>	check Model Coding and Output Ratings table	8	-	48	V
<b>Output Current</b>	check Model Coding and Output Ratings table	350	-	1500	mA
<b>Ripple Current</b>	lout_pk-pk/RMS (except for models identified in the table below)	-	-	40	%
<b>Output Regulation</b>		-	-	±5	%lout
<b>Start-up time</b>	With no dimmer connected	-	-	500	ms

**PROTECTION FEATURES**

Specification	Test Conditions / Notes	Min.	Nominal	Max.	Units
<b>Output Short-Circuit</b>	Hiccup, Auto recovery	-	-	-	-
<b>Over-Temperature Top Case</b>	Hiccup, Auto recovery	-	-	90	°C
<b>No Load</b>	Unit will not exceed "Vout No_Load" in Table 1	-	-	V_No_Load	V
<b>Isolation Primary-to-Secondary</b>	Reinforced/double Insulation meets IEC/EN61347-2-13 Class II				

## LINE DIMMING

Current Dimming of the driver is possible with standard TRIAC based incandescent dimmers that chop the AC voltage, or with ELV dimmers. During the rapid rise time of the AC voltage when the dimmer turns on, the driver does not generate any voltage or current oscillations, and inrush current is controlled. During the on-time of the AC input, the driver regulates the output. The RMS value of the driver output current is proportional to the on-time of the AC input voltage. The RMS output current varies depending upon the conduction angle and RMS value of the applied AC input voltage.

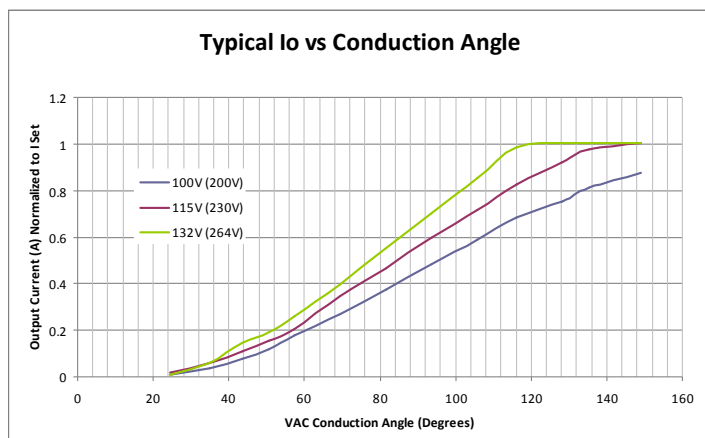
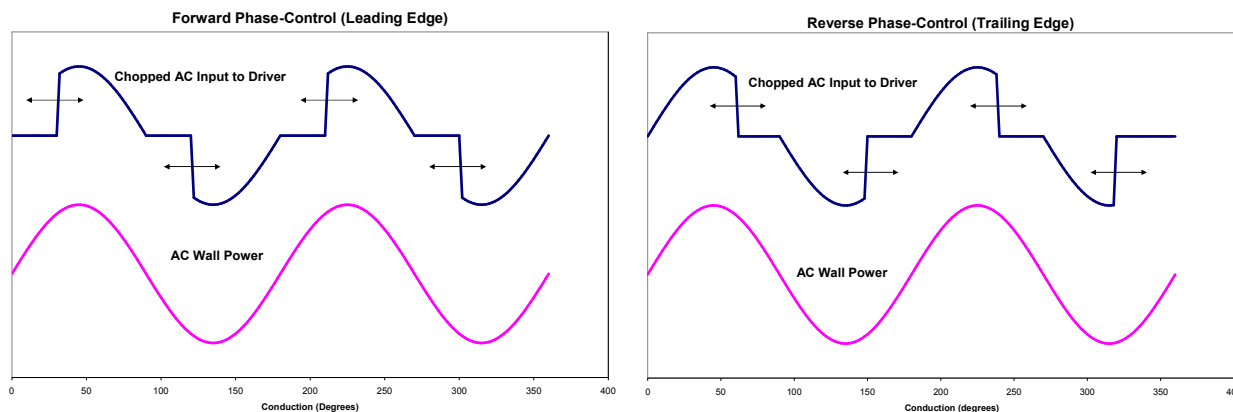

**Output Control:** Output Dims without any flicker.

Total dimming range is as follows:

**Conduction Angle/output:** 180 degrees/100% max  
30 degrees/10% min

## COMPATIBLE LINE DIMMERS:

TROPO drivers are designed to operate with most standard dimmers. However, it has been performed extensive testing with the dimmers listed below. This list of dimmers does not imply any guarantee or warranty of compatibility with a particular application. The lack of dimmers on this list does not imply it is not compatible with TROPO drivers.

Cooper, Aspire Series (Part numbers 9530XXX)  
 Leviton, Illumitech Series (Part numbers IPI06-XXX)  
 Leviton, Trimatron Series (Part numbers 6602-X, 6681-X, 6683-X, 6684-X, 700-X and 705-X)  
 Leviton, SureSlide Series (Part Numbers 6631)  
 Leviton, True Touch Series (Part Number 6606-1LM)  
 Lutron Skylark Series (Part Number S-600, S2-LH)

In addition, the following Electronic Low Voltage (ELV) dimmers that employ reverse phase control have been tested with TROPO:

Lutron Nova T Series (Part number NTELV-600)  
 Lutron Faedra (Part Number FAELV-500-XX)  
 Leviton Acenti (Part Number ACE06-XXX)  
 Leviton Vizia (Part Number VZE04)

Refer to Tropo Application Note #1, Line Voltage Dimming of Tropo drivers, for further information.

**MECHANICAL DETAILS**

Enclosure Material: Partially encapsulated with ABS plastic body enclosure  
 I/O Connections: Flying leads, 18AWG, 152mm long, 105C Rated, Stranded, Stripped by approximately 9.5mm and tinned  
 Mounting Details: Universal Mounting Clips and 6 mounting locations per package allow installer to choose the most suitable position for the mounting feet  
 Ingress Protection: IP 20, UL damp rated

Weight: 145g = 5.10z  
 Dimensions: 82 x 56 x 29 mm  
 3.21 x 2.21 x 1.13 in

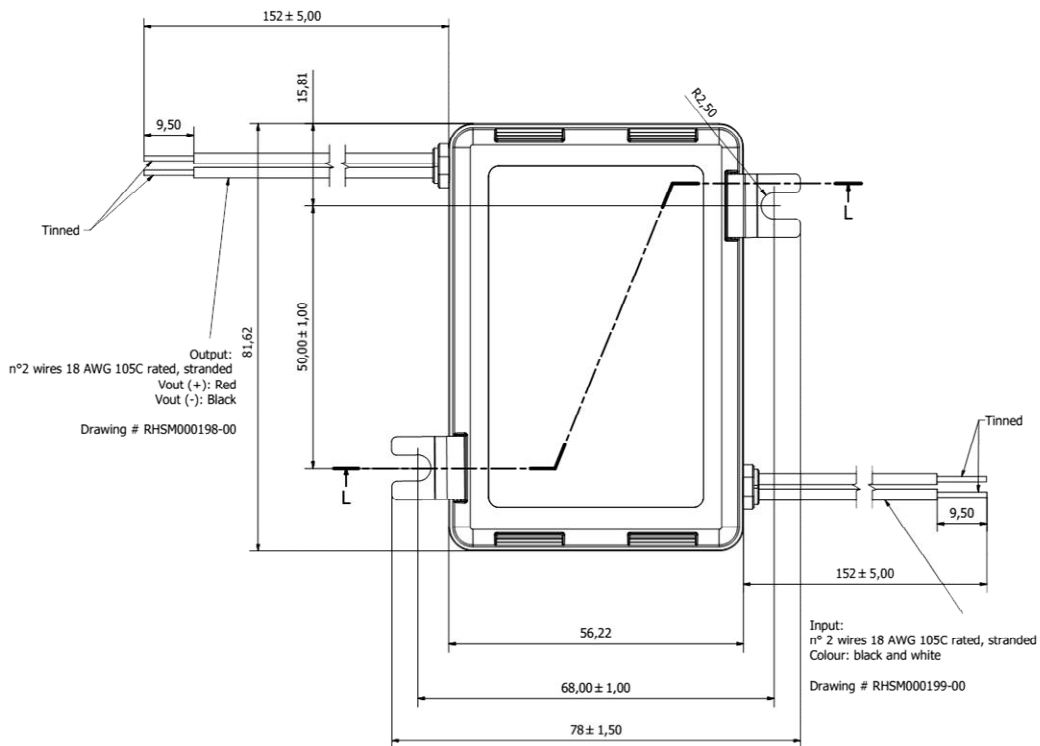
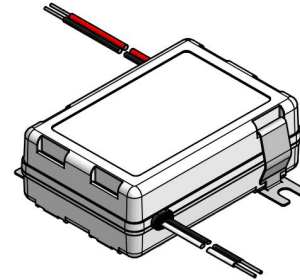

**ENVIRONMENTAL SPECIFICATIONS**

Specification	Test Conditions / Notes	Min	Nom	Max	Units
<b>Top Case Temperature Range</b>	Refer to the Top Case measurement point	-30	-	90	°C
<b>Storage Temperature</b>		-40	-	85	°C
<b>Operating Relative Humidity</b>	Non-condensing	5	-	95	%
<b>Surface Temperature</b>	Exposed surfaces temperature under all operating conditions	-	-	90	°C
<b>Cooling</b>	Convection cooled	-	-	-	
<b>Shock EN 60068-2-27</b>	Operating: Half sine, 30 g, 18 ms, 3 axes, 6x each (3 positive and 3 negative). Non-Operating: Half sine, 50 g, 11 ms, 3 axes, 6x each (3 positive and 3 negative).				
<b>Vibration EN 60068-2-64</b>	Operating: 5 – 500Hz, 1gRMS (0.02 g <sup>2</sup> /Hz), 3 axes, 30 min. Non-Operating: 5 – 500Hz, 2.46gRMS (0.0122 g <sup>2</sup> /Hz), 3 axes, 30 min.				
<b>Vibration EN 60068-2-6</b>	Operating Sine, 10 – 500Hz, 1g, 3 axes, 1 oct/min., 60 min.				
<b>MTBF</b>	Rated Load, 90°C Top Case, Bellcore	500k	-	-	Hours
<b>Useful Life</b>	90°C Top Case.	-	50k	-	Hours





**ELECTROMAGNETIC COMPATIBILITY (EMC) – EMISSIONS**

Phenomenon	Conditions / Notes	Standard	Equipment Performance Class
<b>Conducted and Radiated Emission</b>	Test at 230V <sub>AC</sub>	EN55015	
<b>Conducted and Radiated Emission</b>	Test at 120V <sub>AC</sub>	FCC CFR47- part 15/subpart B	Class B
<b>Harmonic Current Emissions</b>		EN61000-3-2	Class C
<b>Voltage Changes, Fluctuation and Flicker</b>		EN61000-3-3	

**ELECTROMAGNETIC COMPATIBILITY (EMC) – IMMUNITY**

Phenomenon	Conditions / Notes	Standard	Note
<b>Equipment for general lighting purposes -EMC Immunity Requirements</b>		EN 61547	
<b>ESD (Electrostatic Discharge)</b>		EN 61000-4-2	
<b>Radiated Radio-Frequency electromagnetic field</b>		EN 61000-4-3	
<b>Electric Fast Transient / Burst</b>	2kV on AC input	EN 61000-4-4	
<b>Surge</b>	Level ±1kV L-N	EN 61000-4-5	
<b>Conducted disturbances induced by Radio-Frequency fields</b>		EN 61000-4-6	
<b>Voltage Dips, short interruptions and Voltage Variations</b>		EN 61000-4-11	
<b>Non repetitive damped oscillatory transient, Ring wave</b>	2.5kV	ANSI C.62.41	Category A

**SAFETY AGENCIES APPROVALS**

Certification Body	Safety Standards	Category
	UL Recognized ANSI / UL60950-1, CSA C22.2 No.60950-1. Models with output voltages <60 V <sub>DC</sub> include UL and CSA approval (cULus) as LVLE output. LED Driver suitable for dry and damp location	
	To obtain the "CE Declaration of Conformity" please contact <a href="mailto:info@efore.com">info@efore.com</a>	
	IEC/EN 61347-2-13 electronic control gear for LED Modules IEC/EN 62384 DC or AC supplied electronic control gear for LED modules – Performance Requirements	
	Reinforced/double Insulation meets IEC/EN61347-2-13 Class II	

Specifications appearing in EFORE's catalogues and brochures as well as any oral statements are not binding. All descriptions, drawings and other particulars (including dimensions, materials and performance data) given by EFORE are as accurate as possible but, being given for general information, and are not binding on EFORE. EFORE makes thus no representation or warranty as to the accuracy of such material. We assume no liability other than as agreed in the terms of the individual contracts and we reserve the right to make technical modifications in the course of our product development. Our product information solely describes our goods and services and is in no way to be construed or interpreted as a quality or condition guarantee. The aforesaid shall not relieve the customer of its obligation to verify the suitability of our Products for the use or application intended by the purchaser. Customers are responsible for their products and applications. EFORE assumes no liability from the use of its products outside of specifications. No license is granted to any intellectual property rights by this document.



CONSTANT CURRENT, LEADING AND TRAILING EDGE DIMMABLE

## TROPO 15W LED DRIVER

**This page intentionally blank**