

## Rad-hard quad LVDS receivers

Datasheet - production data

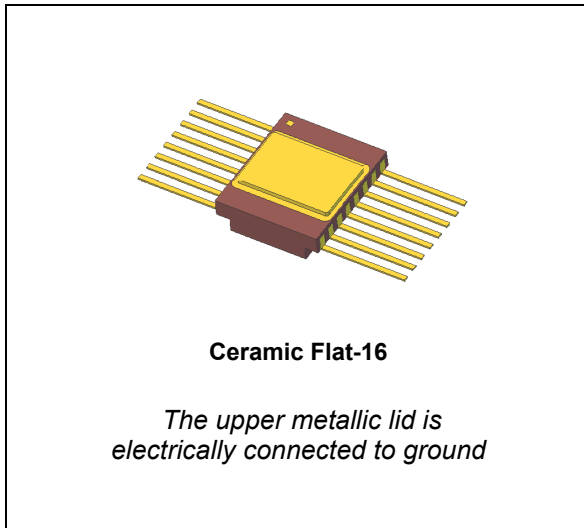

- Large input common mode: -4 V to +5 V
- Guaranteed up to 300 krad TID
- SEL immune up to 135 MeV.cm<sup>2</sup>/mg
- SET/SEU immune up to 32 MeV.cm<sup>2</sup>/mg

### Description

The RHFLVDS32A is a quad, low-voltage differential signaling (LVDS) receiver specifically designed, packaged and qualified for use in aerospace environments in a low-power and fast data transmission standard.

The circuit features an internal fail-safe function to ensure a known state in case of an input short circuit or a floating input.

All pins have cold spare buffers to ensure they are in high impedance when  $V_{CC}$  is tied to GND.

Designed on ST's proprietary CMOS process with specific mitigation techniques, the RHFLVDS32A achieves "best in the class" for hardness to total ionisation dose and heavy ions.

The RHFLVDS32A can operate over a large temperature range of -55 °C to +125 °C and it is housed in an hermetic Ceramic Flat-16 package.

### Features

- LVDS input
- CMOS output
- ANSI TIA/EIA-644 compliant
- 400 Mbps (200 MHz)
- Cold spare on all pins
- Fail-safe function
- 3.3 V operating power supply
- 4.8 V absolute rating
- Power consumption: 43 mW at 3.3 V
- Hermetic package

**Table 1. Device summary**

Reference	SMD pin	Quality level	Package	Lead finish	Mass	EPPL <sup>(1)</sup>	Temp. range
RHFLVDS32AK1	-	Engineering model	Ceramic Flat-16	Gold	-	-	-55 °C to 125 °C
RHFLVDS32AK01V	5962F98652	QML-V Flight				Target	

1. EPPL = ESA preferred part list

# Contents

1	Functional description .....	3
2	Pin configuration .....	4
3	Maximum ratings and operating conditions .....	5
4	Radiation .....	6
5	Electrical characteristics .....	7
6	Test circuit .....	9
7	Package information .....	11
	7.1 Ceramic Flat-16 package information .....	12
8	Ordering information .....	13
9	Shipping information .....	13
10	Revision history .....	14



# 1 Functional description

Figure 1. Logic diagram and logic symbol

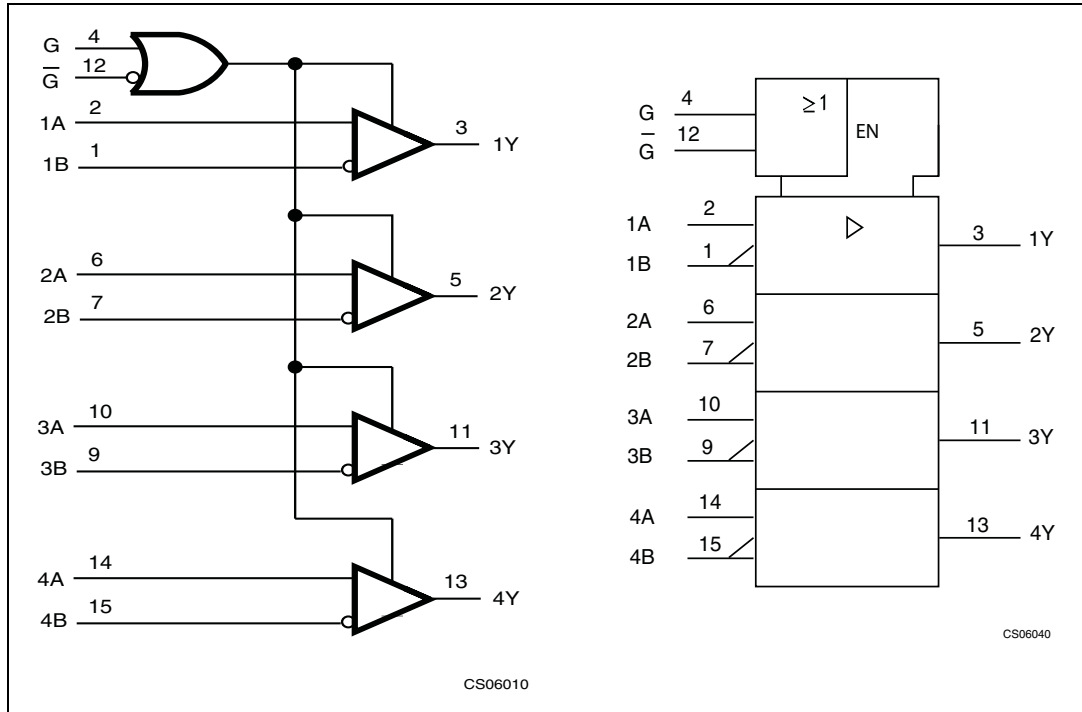

Table 2. Truth table

Differential inputs <b>A, B</b>	Enables		Output
	<b>G</b>	<b>Ḡ</b>	<b>Y</b>
$V_{ID} \geq 100 \text{ mV}$	H	X	H
	X	L	H
$-100 \text{ mV} < V_{ID} < 100 \text{ mV}$	H	X	?
	X	L	?
$V_{ID} \leq -100 \text{ mV}$	H	X	L
	X	L	L
X	L	H	Z
Open/Short or terminated	H	X	H
	X	L	H

- Note:
- 1 The G input features an internal pull-up network. The  $\bar{G}$  input features an internal pull-down network. If they are floating the circuit is enabled.
  - 2  $V_{id} = V_{IA} - V_{IB}$
  - 3 L = low level, H = high Level, X = irrelevant, Z = high impedance (off). ? = intermediate

## 2 Pin configuration

Figure 2. Pin connections (top view)

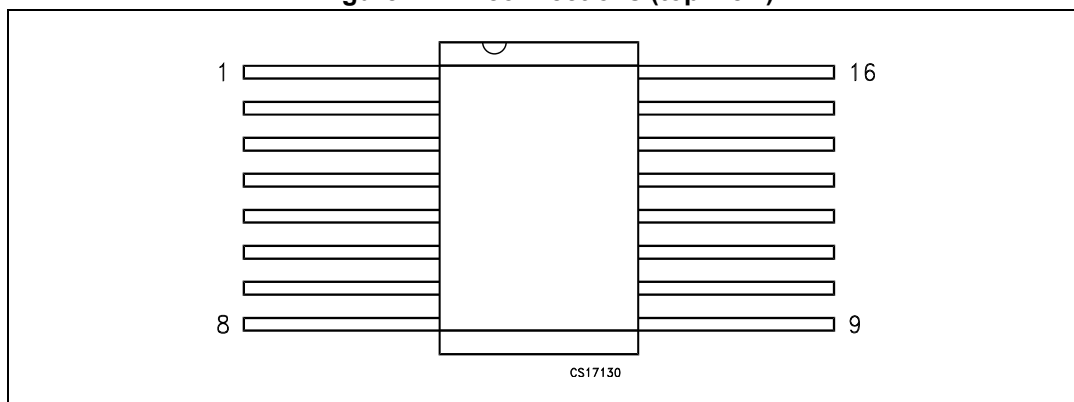

Table 3. Pin description

Pin number	Symbol	Name and function
2, 6, 10, 14	1A to 4A	Receiver inputs
1, 7, 9, 15	1B to 4B	Negated receiver inputs
3, 5, 11, 13	1Y to 4Y	Receiver outputs
4	G	Enable
12	$\overline{G}$	
8	GND	Ground
16	V <sub>CC</sub>	Supply voltage

### 3 Maximum ratings and operating conditions

Absolute maximum ratings are those values beyond which damage to the device may occur. Functional operation under these conditions is not implied.

**Table 4. Absolute maximum ratings**

Symbol	Parameter	Value	Unit
$V_{CC}$	Supply voltage <sup>(1)</sup>	4.8	V
$V_i$	TTL inputs (operating or cold-spares)	-0.3 to 4.8	
$V_{CM}$	LVDS common mode (operating or cold-spares)	-5 to +6	
$V_{OUT}$	TTL outputs (operating or cold-spares)	-0.3 to 4.8	
$T_{stg}$	Storage temperature range	-65 to +150	°C
$T_j$	Maximum junction temperature	+150	
$R_{thjc}$	Thermal resistance junction to case <sup>(2)</sup>	22	°C/W
ESD	HBM: Human body model		kV
	– All pins excepted LVDS inputs	2	
	– LVDS inputs vs. GND	8	
	CDM: Machine model	500	V

1. All voltages, except differential I/O bus voltage, are with respect to the network ground terminal.
2. Short-circuits can cause excessive heating. Destructive dissipation can result from short-circuits on the amplifiers.

**Table 5. Operating conditions**

Symbol	Parameter	Min.	Typ.	Max.	Unit
$V_{CC}$	Supply voltage	3	3.3	3.6	V
$V_{CM}$	Static common mode on the receiver	- 4		+ 5	
$T_A$	Ambient temperature range	-55		+125	°C

## 4 Radiation

### Total dose (MIL-STD-883 TM 1019)

The products guaranteed in radiation within the RHA QML-V system fully comply with the MIL-STD-883 TM 1019 specification.

The RHFLVDS32A is RHA QML-V, tested and characterized in full compliance with the MIL-STD-883 specification, between 50 and 300 rad/s only (full CMOS technology).

All parameters provided in [Table 7: Electrical characteristics](#) apply to both pre- and post-irradiation, as follows:

- All test are performed in accordance with MIL-PRF-38535 and test method 1019 of MIL-STD-883 for total ionizing dose (TID).
- The initial characterization is performed in qualification only on both biased and unbiased parts.
- Each wafer lot is tested at high dose rate only, in the worst bias case condition, based on the results obtained during the initial qualification.

### Heavy ions

The behavior of the product when submitted to heavy ions is not tested in production. Heavy-ion trials are performed on qualification lots only.

**Table 6. Radiations**

Type	Characteristics	Value	Unit
TID	High-dose rate (50 - 300 rad/sec) up to:	300	krad
Heavy ions	SEL immune up to: (with a particle angle of 60 ° at 125 °C)	135	MeV.cm <sup>2</sup> /mg
	SEL immune up to: (with a particle angle of 0 ° at 125 °C)	67	
	SET/SEU immune up to: (at 25 °C)	32	

## 5 Electrical characteristics

In [Table 7](#) below,  $V_{CC} = 3\text{ V}$  to  $3.6\text{ V}$ , capa-load (CL) =  $10\text{ pF}$ , typical values are at  $T_{amb} = +25\text{ }^{\circ}\text{C}$ , min. and max values are at  $T_{amb} = -55\text{ }^{\circ}\text{C}$  and  $+125\text{ }^{\circ}\text{C}$  unless otherwise specified

**Table 7. Electrical characteristics**

Symbol	Parameter	Test conditions	Min.	Typ.	Max.	Unit
$I_{CC}$	Total enabled supply current, receivers enabled, not switching	$V_{ID} = 400\text{ mV}$		13	15	mA
$I_{CCZ}$	Total disabled supply current, receivers disabled	$V_{ID} = 400\text{ mV}$ $G = \text{GND}$ and $\overline{G} = V_{CC}$			4	
$I_{OFF}$	LVDS input power-off leakage current <sup>(1)</sup>	$V_{CC} = 0\text{ V}$ , $V_{IN} = -4\text{ V}$ to $5\text{ V}$	-60		60	$\mu\text{A}$
	TTL I/O power-off leakage current <sup>(1)</sup>	$V_{CC} = 0\text{ V}$ , $\overline{\text{G}}$ $V_{IN}$ , $G$ and $\overline{G} = 3.6\text{ V}$ , $V_{OUT} = 3.6\text{ V}$	-10		10	
$V_{IH}$	Enable threshold high level	G and $\overline{G}$ inputs	2		$V_{CC}$	V
$V_{IL}$	Enable threshold low level		GND		0.8	
$I_{IH}$	High level input current	G and $\overline{G}$ inputs $V_{CC} = 3.6\text{ V}$ , $V_{IN} = V_{CC}$	-10		10	$\mu\text{A}$
$I_{IL}$	Low level input current	G and $\overline{G}$ inputs $V_{CC} = 3.6\text{ V}$ , $V_{IN} = 0$	-10		10	
$V_{TL}$	Differential input low threshold	$V_{CM} = 1.2\text{ V}$			-100	mV
		$-4\text{ V} < V_{CM} < +5\text{ V}$			-130	
$V_{TH}$	Differential input high threshold	$V_{CM} = 1.2\text{ V}$	100			
		$-4\text{ V} < V_{CM} < +5\text{ V}$	130			
$V_{CL}$	TTL input clamp voltage	$I_{CL} = 18\text{ mA}$			1.5	V
$V_{CMR}$	Common mode voltage range	$V_{ID} = 200\text{ mVp-p}$	-4		+5	
$V_{CMREJ}$	Common mode rejection <sup>(2)</sup>	$F = 10\text{ MHz}$		300		mVp-p
$I_{ID}$	Differential input current	$V_{ID} = 400\text{ mVp-p}$	-10		10	$\mu\text{A}$
$I_{ICM}$	Common mode input current	$V_{IC} = -4\text{ V}$ to $+5\text{ V}$	-70		70	
$V_{OH}$	Output voltage high	$I_{OH} = -0.4\text{ mA}$ , $V_{CC} = 3\text{ V}$	2.7			V
$V_{OL}$	Output voltage low	$I_{OL} = 2\text{ mA}$ , $V_{CC} = 3\text{ V}$			0.25	
$I_{OS}$	Output short-circuit current	$V_{OUT} = 0\text{ V}$	-90		-30	mA
$I_{OZ}$	Output tri-state current	Disabled, $V_{OUT} = 0\text{ V}$ or $V_{CC}$	-10		10	$\mu\text{A}$
$C_{IN}$	Input capacitance	On each LVDS input vs. GND		3		pF
$R_{out}$	Output resistance			45		$\Omega$

Table 7. Electrical characteristics (continued)

Symbol	Parameter	Test conditions	Min.	Typ.	Max.	Unit
$t_{PHLD}$	Propagation delay time, high to low output	$V_{ID} = 200$ mVp-p, input pulse from 1.1 V to 1.3 V, $V_{CM} = 1.2$ V Load: refer to <a href="#">Figure 3</a>	1		2.5	ns
$t_{PLHD}$	Propagation delay time, low to high output		1		2.5	
$t_{SK1}$	Channel to channel skew <sup>(3)</sup>	$V_{ID} = 200$ mVp-p Load: refer to <a href="#">Figure 3</a>			0.25	ns
$t_{SK2}$	Chip to chip skew <sup>(4)(5)</sup>				0.7	
$t_{SKD}$	Differential skew <sup>(6)</sup> ( $t_{PHLD} - t_{PLHD}$ )				0.3	
$t_r$	Output signal rise time	Load: refer to <a href="#">Figure 3</a>		0.9		
$t_f$	Output signal fall time			0.9		
$t_{PLZ}$	Propagation delay time, low level to high impedance output	Load: refer to <a href="#">Figure 4</a>			3.8	
$t_{PHZ}$	Propagation delay time, high level to high impedance output				3.8	
$t_{PZH}$	Propagation delay time, high impedance to high level output				3.8	
$t_{PZL}$	Propagation delay time, high impedance to low level output				3.8	
$t_{D1}$	Fail-safe to active time			1		μs
$t_{D2}$	Active to fail-safe time			1		

1. All pins except pin under test and  $V_{CC}$  are floating.
2. Guaranteed by characterization on the bench.
3.  $t_{SK1}$  is the maximum delay time difference between all outputs of the same device (measured with all inputs connected together).
4.  $t_{SK2}$  is the maximum delay time difference between outputs of all devices when they operate with the same supply voltage, at the same temperature.
5. Guaranteed by design.  $t_{SKD}$  is the maximum delay time difference between  $t_{PHLD} - t_{PLHD}$
6.  $t_{SKD}$  is the maximum delay time difference between  $t_{PHLD}$  and  $t_{PLHD}$ , see [Figure 3](#).

### Cold sparing

The RHFLVDS32A features a cold spare input and output buffer. In high reliability applications, cold sparing enables a redundant device to be tied to the data bus with its power supply at 0 V ( $V_{CC} = GND$ ) without affecting the bus signals or injecting current from the I/Os to the power supplies. Cold sparing also allows redundant devices to be kept powered off so that they can be switched on only when required. This has no impact on the application. Cold sparing is achieved by implementing a high impedance between the I/Os and  $V_{CC}$ . The ESD protection is ensured through a non-conventional dedicated structure.

### Fail-safe

In many applications, inputs need a fail-safe function to avoid an uncertain output state when the inputs are not connected properly. In case of an LVDS input short circuit or floating inputs, the TTL outputs remain in stable logic-high state.

# 6 Test circuit

Figure 3. Timing test circuit and waveform

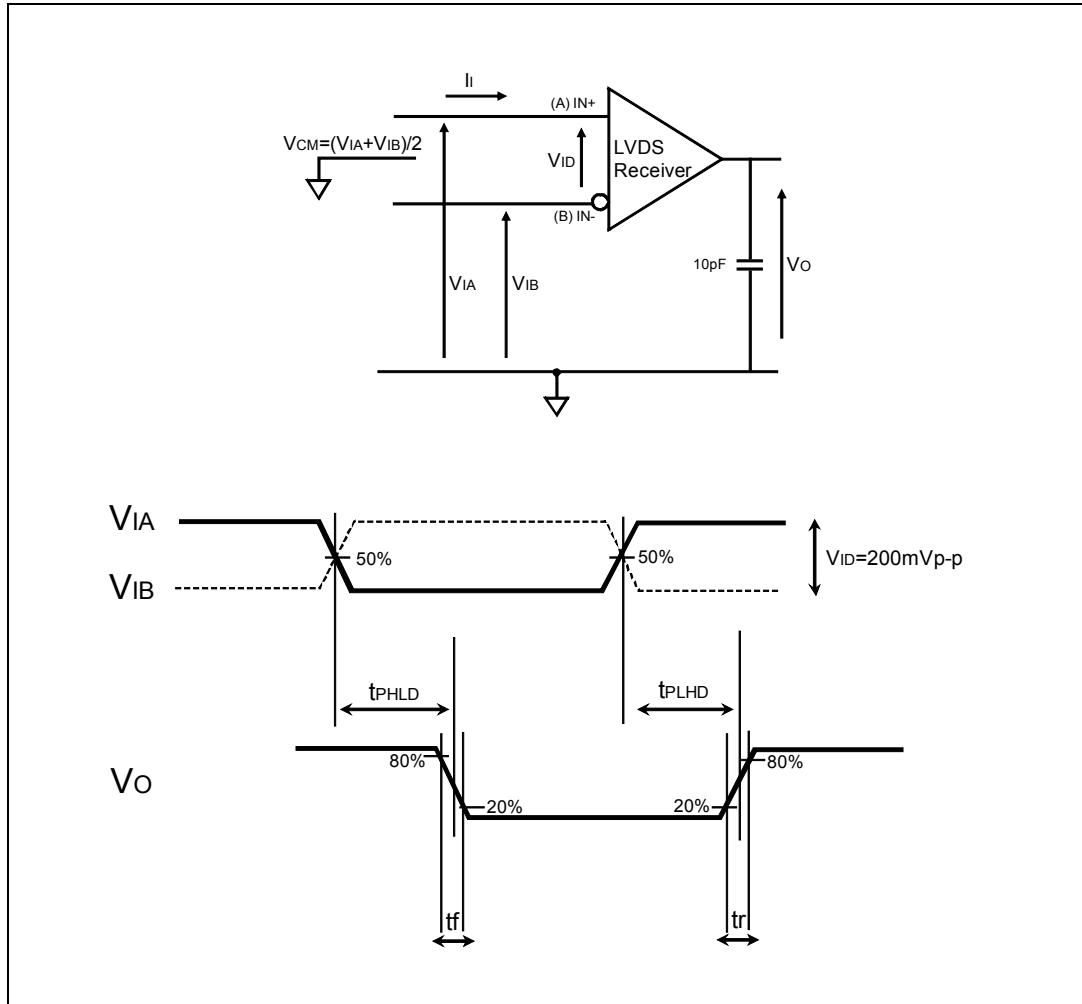

1. All input pulses are supplied by a generator with the following characteristics:  $t_r$  or  $t_f \leq 1$  ns,  $f = 1$  MHz,  $Z_O = 50 \Omega$ , and duty cycle = 50%.
2. The product is guaranteed in test with  $CL = 10$  pF

Figure 4. Enable and disable time test circuit and waveform

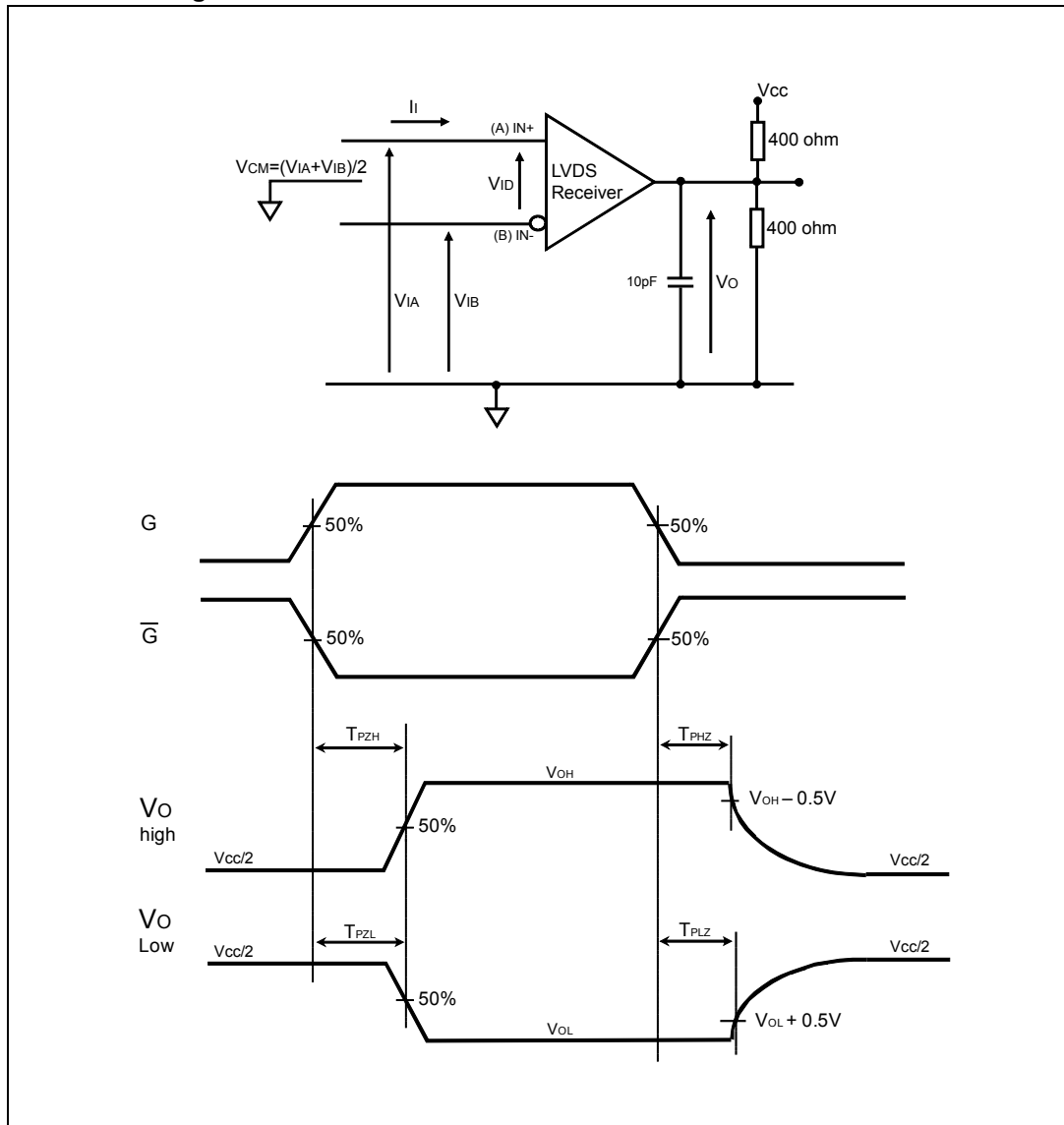

1. All input pulses (including  $G$  and  $\bar{G}$ ) are supplied by a generator with the following characteristics:  $t_r$  or  $t_f \leq 1$  ns,  $f_G$  or  $f_{\bar{G}} = 500$  kHz, and pulse width  $G$  or  $\bar{G} = 500$  ns.
2. The product is guaranteed in test with  $C_L = 10$  pF

## 7 Package information

In order to meet environmental requirements, ST offers these devices in different grades of ECOPACK<sup>®</sup> packages, depending on their level of environmental compliance. ECOPACK<sup>®</sup> specifications, grade definitions and product status are available at: [www.st.com](http://www.st.com). ECOPACK<sup>®</sup> is an ST trademark.

### 7.1 Ceramic Flat-16 package information

Figure 5. Ceramic Flat 16 package mechanical drawing

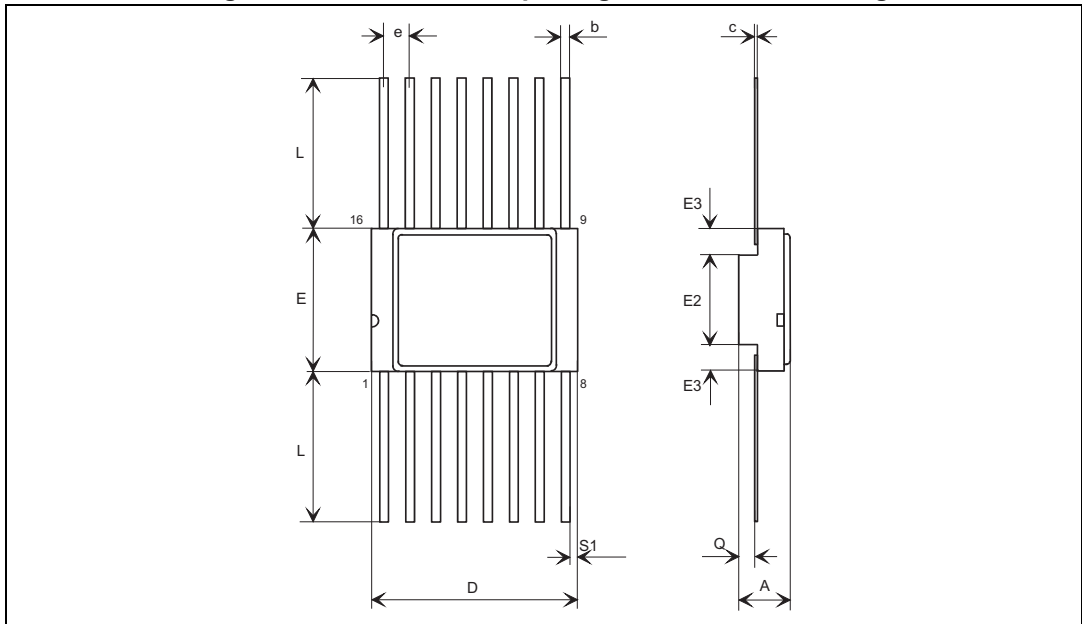

1. The upper metallic lid is electrically connected to ground.

Table 8. Ceramic Flat 16 package mechanical data

Ref.	Dimensions					
	Millimeters			Inches		
	Min.	Typ.	Max.	Min.	Typ.	Max.
A	2.31		2.72	0.091		0.107
b	0.38		0.48	0.015		0.019
c	0.10		0.18	0.004		0.007
D	9.75		10.13	0.384		0.399
E	6.75		7.06	0.266		0.278
E2		4.32			0.170	
E3	0.76			0.030		
e		1.27			0.050	
L	6.35		7.36	0.250		0.290
Q	0.66		1.14	0.026		0.045
S1	0.13			0.005		

## 8 Ordering information

Table 9. Order codes

Order code	Description	Temp. range	Package	Marking <sup>(1)</sup>	Packing
RHFLVDS32AK1	Engineering model	-55 °C to 125 °C	Ceramic Flat-16	RHFLVDS32AK1	Strip pack
RHFLVDS32AK01V	QML-V flight			5962F9865207VZC	

1. Specific marking only. Complete marking includes the following:
- SMD pin (on QML-V flight only)
  - ST logo
  - Date code (date the package was sealed) in YYWWA (year, week, and lot index of week)
  - QML logo (Q or V)
  - Country of origin (FR = France).

*Note:* Contact your ST sales office for information regarding the specific conditions for products in die form and QML-Q versions.

## 9 Shipping information

### Date code

The date code is structured as follows:

- Engineering model: EM xyywwz
- QML flight model: FM yywwz

Where:

x = 3 (EM only), assembly location Rennes (France)

yy = last two digits of the year

ww = week digits

z = lot index of the week

## 10 Revision history

Table 10. Document revision history

Date	Revision	Changes
29-Oct-2013	1	Initial release
30-Oct-2014	2	<ul style="list-style-type: none"><li>– Updated production status and marking information relative to order code RHFLVDS32AK01V in <a href="#">Table 1: Device summary</a> and <a href="#">Table 9: Order codes</a>.</li><li>– Removed row regarding CL parameter from <a href="#">Table 5: Operating conditions</a>.</li><li>– Changed title of <a href="#">Section 4</a> to “Radiation” and moved <a href="#">Electrical characteristics</a> to <a href="#">Section 5</a>.</li></ul>
04-Mar-2015	3	<ul style="list-style-type: none"><li>– Added <math>V_{OUT}</math> to <a href="#">Table 4: Absolute maximum ratings</a>.</li><li>– Added <math>V_{CL}</math> to <a href="#">Table 7: Electrical characteristics</a>.</li></ul>

**IMPORTANT NOTICE – PLEASE READ CAREFULLY**

STMicroelectronics NV and its subsidiaries ("ST") reserve the right to make changes, corrections, enhancements, modifications, and improvements to ST products and/or to this document at any time without notice. Purchasers should obtain the latest relevant information on ST products before placing orders. ST products are sold pursuant to ST's terms and conditions of sale in place at the time of order acknowledgement.

Purchasers are solely responsible for the choice, selection, and use of ST products and ST assumes no liability for application assistance or the design of Purchasers' products.

No license, express or implied, to any intellectual property right is granted by ST herein.

Resale of ST products with provisions different from the information set forth herein shall void any warranty granted by ST for such product.

ST and the ST logo are trademarks of ST. All other product or service names are the property of their respective owners.

Information in this document supersedes and replaces information previously supplied in any prior versions of this document.

© 2015 STMicroelectronics – All rights reserved

