

Rad-hard advanced high-speed 5 V CMOS logic series

Data brief

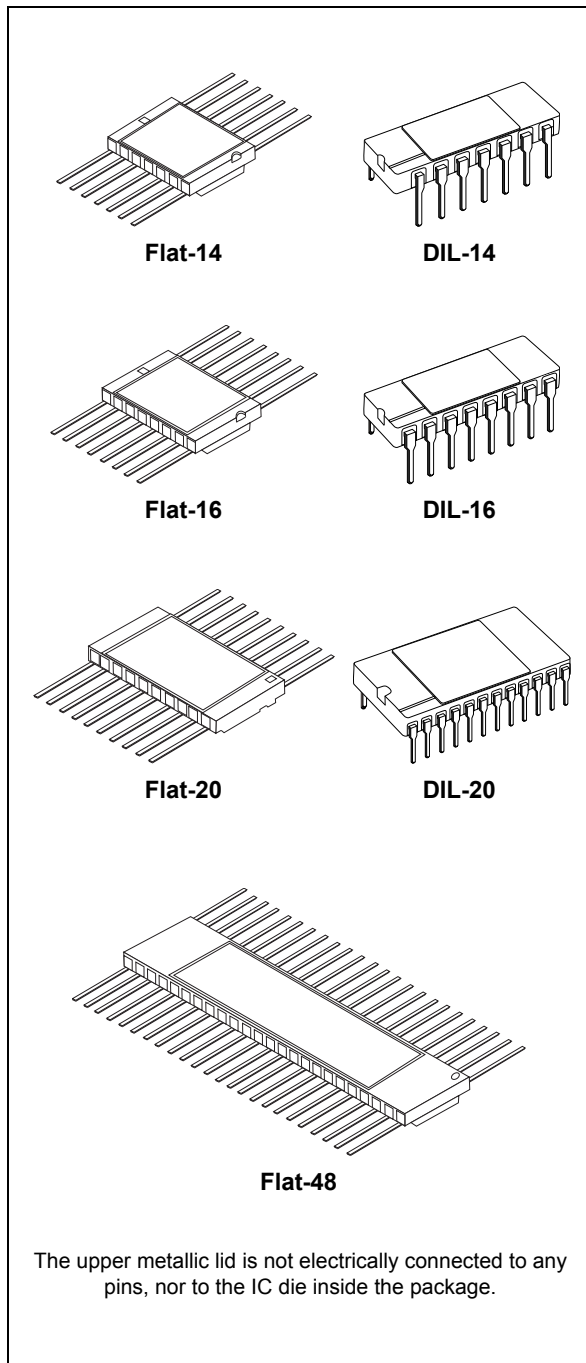

Features

- AC: 2 to 6 V operating voltage
- ACT: 4.5 to 5.5 V operating voltage
- High speed $T_{PD} = 4.5$ ns (typ.)
- Low DC power dissipation: 8 μ A max.
- Symmetrical 24 mA output characteristics
- High noise immunity: 28% of min. V_{CC}
- Power-down input protection
- Balanced propagation delays
- Improved electrical latch-up immunity
- Controlled rise and fall times
- Operating temperature: - 55 to 150 °C
- Hermetic packages
- Rad-hard: 300 kRad TID at any Mil1019 dose rates
- SEL immune to 110 MeV/cm²/mg LET ions
- RHA QML-V qualified
- Same die and electrical specification for engineering and flight models

Description

The 54AC and 54ACT series represent over 60 product types with different high-speed CMOS functions, specifically designed to meet the radiation requirements of the aerospace industry. They include a large set of gates, flip-flops, multiplexers, counters, bus interfaces, and several other functions. Their radiation hardness, immunity from single event latch-up (SEL) and single event upset (SEU), and housing in hermetic packages make them suitable for the most difficult environmental conditions. The complete specification for each type is available from the DSCC web site: www.dsccl.dla.mil. STMicroelectronics guarantees full compliance of qualified parts with these DSCC specifications.

Contents

- 1 54AC and 54ACT series overview 5**
- 2 Input and output equivalent circuit diagram 8**
- 3 Maximum rating 9**
 - 3.1 Absolute maximum ratings 9
 - 3.1.1 54AC series 9
 - 3.1.2 54ACT series 9
 - 3.2 Recommended operating conditions 10
 - 3.2.1 54AC series 10
 - 3.2.2 54ACT series 10
- 4 Package mechanical data 11**
- 5 Ordering information 18**
- 6 Other information 27**
 - 6.1 Date code 27
 - 6.2 Documentation 27
- 7 Revision history 28**

List of tables

Table 1.	Device summary	5
Table 2.	Absolute maximum ratings - 54AC series.	9
Table 3.	Absolute maximum ratings - 54ACT series.	9
Table 4.	Recommended operating conditions for 54AC series	10
Table 5.	Recommended operating conditions for 54ACT series	10
Table 6.	Ceramic Flat-14 (MIL-STD-1835) package mechanical data	11
Table 7.	Ceramic DIL-14 (MIL-STD-1835) package mechanical data	12
Table 8.	Ceramic Flat-16 (MIL-STD-1835) package mechanical data	13
Table 9.	Ceramic DIL-16 (MIL-STD-1835) package mechanical data	14
Table 10.	Ceramic Flat-20 package mechanical data	15
Table 11.	Ceramic DIL-20 (MIL-STD-1835) package mechanical data	16
Table 12.	Ceramic Flat-48 package mechanical data	17
Table 13.	Ordering information	18
Table 14.	Documentation provided for QML-V flight.	27
Table 15.	Document revision history	28

List of figures

Figure 1.	Input and output equivalent circuit diagram	8
Figure 2.	Ceramic Flat-14 package outline	11
Figure 3.	Ceramic DIL-14 package outline	12
Figure 4.	Ceramic Flat-16 package outline	13
Figure 5.	Ceramic DIL-16 package outline	14
Figure 6.	Ceramic Flat-20 package outline	15
Figure 7.	Ceramic DIL-20 package outline	16
Figure 8.	Ceramic Flat-48 package outline	17

1 54AC and 54ACT series overview

Table 1. Device summary

Part number	Description	Radiation level	Agency qualification	EPPL	SMD / detailed specification	Package	Other features
54AC00	Rad-hard quad 2-input NAND gate	300 krad (Si)	QML-V	Y	5962F87549	Flat-14 - DIL-14	-
54ACT00	Rad-hard quad 2-input NAND gate			Y	5962F87699	Flat-14 - DIL-14	
54AC02	Rad-hard quad 2-input NOR gate			Y	5962F87612	Flat-14 - DIL-14	
54ACT02	Rad-hard quad 2-input NOR gate			-	5962F89791	Flat-14 - DIL-14	
54AC04	Rad-hard hex inverter			Y	5962F87609	Flat-14 - DIL-14	
54ACT04	Rad-hard hex inverter			-	5962F89734	Flat-14 - DIL-14	
54AC08	Rad-hard quad 2-input AND gate			Y	5962F87615	Flat-14 - DIL-14	
54ACT08	Rad-hard quad 2-input AND gate			-	5962F89547	Flat-14 - DIL-14	
54AC10	Rad-hard triple 3-input NAND gate			Y	5962F87610	Flat-14 - DIL-14	
54ACT10	Rad-hard triple 3-input NAND gate			-	5962F92182	Flat-14 - DIL-14	
54AC11	Rad-hard triple 3-input AND gate			Y	5962F87611	Flat-14 - DIL-14	
54ACT11	Rad-hard triple 3-input AND gate			-	5962F90772	Flat-14 - DIL-14	
54AC14	Rad-hard hex Schmitt inverter			Y	5962F87624	Flat-14 - DIL-14	
54AC14A	Rad-hard hex Schmitt inverter low power			-	5962F87624	Flat-14 - DIL-14	
54ACT14	Rad-hard hex Schmitt inverter			-	5962F96813	Flat-14 - DIL-14	
54AC32	Rad-hard quad 2-input OR gate			-	5962F87614	Flat-14 - DIL-14	
54ACT32	Rad-hard quad 2-input OR gate			-	5962F89736	Flat-14 - DIL-14	
54AC74	Rad-hard dual D-type flip-flop with preset and clear			Y	5962F88520	Flat-14 - DIL-14	
54ACT74	Rad-hard dual D-type flip-flop with preset and clear			-	5962F87525	Flat-14 - DIL-14	
54AC86	Rad-hard quad exclusive OR			-	5962F89550	Flat-14 - DIL-14	

**Table 1. Device summary (continued)**

Part number	Description	Radiation level	Agency qualification	EPPL	SMD / detailed specification	Package	Other features	
54ACT86	Rad-hard quad exclusive OR	300 krad (Si)	QML-V	Y	5962F90687	Flat-14 - DIL-14		
54AC138	Rad-hard 3 to 8 line decoder inverter			Y	5962F87622	Flat-16 - DIL-16		
54ACT138	Rad-hard 3 to 8 line decoder inverter			-	5962F87554	Flat-16 - DIL-16		
54AC139	Rad-hard dual 2 to 4 line decoder/demultiplexer			Y	5962F87623	Flat-16 - DIL-16		
54ACT139	Rad-hard dual 2 to 4 line decoder/demultiplexer			-	5962F87553	Flat-16 - DIL-16		
54AC151	Rad-hard 8-channel multiplexer			-	5962F87691	Flat-16 - DIL-16		
54ACT151	Rad-hard 8-channel multiplexer			-	5962F88756	Flat-16 - DIL-16		
54AC157	Rad-hard quad 2-channel multiplexer			Y	5962F89539	Flat-16 - DIL-16		
54ACT157	Rad-hard quad 2-channel multiplexer			-	5962F89668	Flat-16 - DIL-16		
54AC161	Rad-hard synchronous binary counter with async. clear			Y	5962F89561	Flat-16 - DIL-16		
54ACT161	Rad-hard synchronous binary counter with async. clear			-	5962F91722	Flat-16 - DIL-16		
54AC174	Rad-hard hex D-type flip-flop with clear			-	5962F87626	Flat-16 - DIL-16		
54ACT174	Rad-hard hex D-type flip-flop with clear			-	5962F87757	Flat-16 - DIL-16		
54AC191	Rad-hard 4-bit synchronous binary up/down counter			-	5962F89749	Flat-16 - DIL-16		
54ACT191	Rad-hard 4-bit synchronous binary up/down counter			-	5962F04228	Flat-16 - DIL-16		
54AC240	Rad-hard octal bus buffer 3-state inverter			Y	5962F87550	Flat-20		
54ACT240	Rad-hard octal bus buffer 3-state inverter			Y	5962F87759	Flat-20		
54AC244	Rad-hard octal bus buffer 3-state			Y	5962F87552	Flat-20		Inverted enable
54ACT244	Rad-hard octal bus buffer 3-state			Y	5962F87760	Flat-20		
54AC245	Rad-hard octal bus transceiver 3-state			Y	5962F87758	Flat-20		
54ACT245	Rad-hard octal bus transceiver 3-state	Y	5962F87663	Flat-20				
54AC273	Rad-hard octal D-type flip-flop with clear	Y	5962F87756	Flat-20				
54ACT273	Rad-hard octal D-type flip-flop with clear	-	5962F01527	Flat-20				

Table 1. Device summary (continued)

Part number	Description	Radiation level	Agency qualification	EPPL	SMD / detailed specification	Package	Other features
54AC373	Rad-hard octal D-type latch 3-state	300 krad (Si)	QML-V	Y	5962F87555	Flat-20	
54ACT373	Rad-hard octal D-type latch 3-state			-	5962F87556	Flat-20	
54AC374	Rad-hard octal D-type flip-flop 3-state			Y	5962F87694	Flat-20	
54ACT374	Rad-hard octal D-type flip-flop 3-state			-	5962F87631	Flat-20	
54AC521 ⁽¹⁾	Rad-hard 8-bit comparator with enable			-	5962F87695	Flat-20	
54AC540 ⁽¹⁾	Rad-hard octal buffer/line driver 3-state			-	5962F90985	Flat-20	
54AC541	Rad-hard octal bus buffer 3-state			Y	5962F88706	Flat-20	Non inverted enable
54ACT541	Rad-hard octal bus buffer 3-state			-	5962F89795	Flat-20	
54AC574	Rad-hard octal D-type flip-flop 3-state			-	5962F96773	Flat-20	
54ACT574	Rad-hard octal D-type flip-flop 3-state			Y	5962F89601	Flat-20	
54AC2525 ⁽¹⁾	Rad-hard 1 to 8 skew clock driver			-	5962F92174	Flat-48	
54AC16244	Rad-hard 16-bit bus transceiver non inverting			-	5962F04210	Flat-48	
54ACT16244	Rad-hard 16-bit bus transceiver non inverting			-	5962F92022	Flat-48	
54AC16245	Rad-hard 16-bit bus transceiver 3-inverting			-	5962F04211	Flat-48	
54ACT16245	Rad-hard 16-bit 3-state buffer transceiver			-	5962F92023	Flat-48	
54AC16373	Rad-hard 16 D-type latch 3-state			-	5962F04212	Flat-48	
54ACT16373	Rad-hard 16-bit 3-state D-type latch			-	5962F92024	Flat-48	
54AC16374	Rad-hard 16 D-type flip flop 3-state	-	5962F04213	Flat-48			
54ACT16374	Rad-hard 16-bit 3-state D-type flip-flop	-	5962F92025	Flat-48			
54AC164245	Rad-hard 16-bit 3 to 5 V level shifter transceiver 3-state	100 krad (Si)	-	5962R98580	Flat-48		

1. The product is not yet formally qualified by DSCC.

Contact ST sales office for information about the specific conditions for other 54AC or 54ACT part numbers, product in die form and QML-Q versions.



2 Input and output equivalent circuit diagram

Figure 1. Input and output equivalent circuit diagram

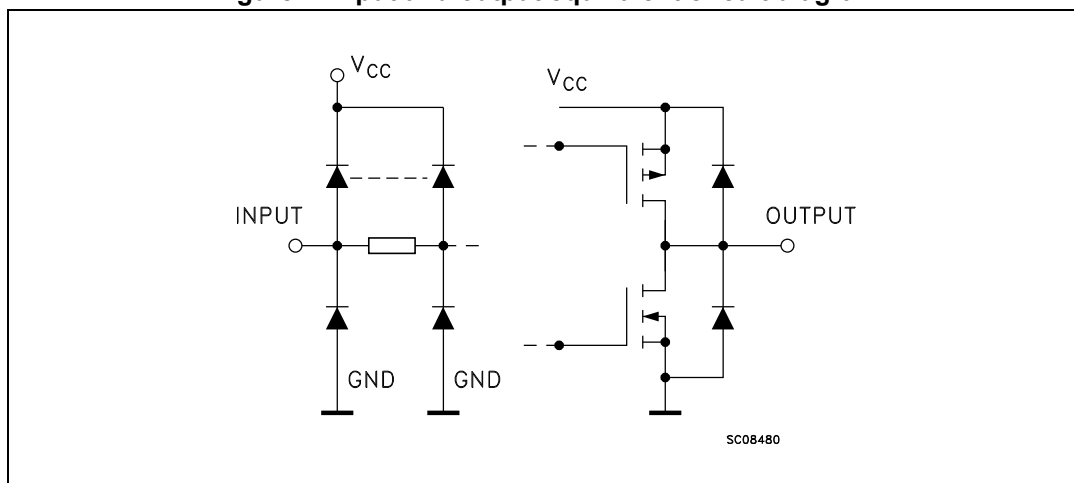

3 Maximum rating

3.1 Absolute maximum ratings

3.1.1 54AC series

Table 2. Absolute maximum ratings - 54AC series

Symbol	Parameter	Value	Unit
V_{CC}	Supply voltage	-0.5 to +7.0	V
V_I	DC input voltage	-0.5 to +7.0	V
V_O	DC output voltage	-0.5 to $V_{CC} + 0.5$	V
I_{IK}	DC input diode current	± 20	mA
I_{OK}	DC output diode current	± 50	mA
I_O	DC output current	± 50	mA
I_{CC} or I_{GND}	DC V_{CC} or ground current	from 100 to 400	mA
T_{STG}	Storage temperature	-65 to +150	°C
T_L	Lead temperature (10 sec)	260	°C

Note: All voltage values are referred to V_{SS} pin voltage.

3.1.2 54ACT series

Table 3. Absolute maximum ratings - 54ACT series

Symbol	Parameter	Value	Unit
V_{CC}	Supply voltage	-0.5 to +6.0	V
V_I	DC input voltage	-0.5 to +6.0	V
V_O	DC output voltage	-0.5 to $V_{CC} + 0.5$	V
I_{IK}	DC input diode current	± 20	mA
I_{OK}	DC output diode current	± 50	mA
I_O	DC output current	± 50	mA
I_{CC} or I_{GND}	DC V_{CC} or ground current	from 100 to 400	mA
T_{STG}	Storage temperature	-65 to +150	°C
T_L	Lead temperature (10 sec)	260	°C

Note: All voltage values are referred to V_{SS} pin voltage.

3.2 Recommended operating conditions

3.2.1 54AC series

Table 4. Recommended operating conditions for 54AC series

Symbol	Parameter	Value	Unit
V_{CC}	Supply voltage	2 to 6	V
V_I	Input voltage	0 to V_{CC}	V
V_O	Output voltage	0 to V_{CC}	V
T_{OP}	Operating temperature	-55 to 150	°C
dt/dv	Input rise and fall time ⁽¹⁾ $V_{CC} = 3.0, 4.5$ or 5.5	0 to 8	ns/V

1. V_{IN} from 30% to 70% of V_{CC} .

3.2.2 54ACT series

Table 5. Recommended operating conditions for 54ACT series

Symbol	Parameter	Value	Unit
V_{CC}	Supply voltage	4.5 to 5.5	V
V_I	Input voltage	0 to V_{CC}	V
V_O	Output voltage	0 to V_{CC}	V
T_{OP}	Operating temperature	-55 to 150	°C
dt/dv	Input rise and fall time ⁽¹⁾ $V_{CC} = 3.0, 4.5$ or 5.5	0 to 8	ns/V

1. V_{IN} from 30% to 70% of V_{CC} .

4 Package mechanical data

In order to meet environmental requirements, ST offers these devices in different grades of ECOPACK® packages, depending on their level of environmental compliance. ECOPACK® specifications, grade definitions and product status are available at: www.st.com. ECOPACK is an ST trademark.

Figure 2. Ceramic Flat-14 package outline

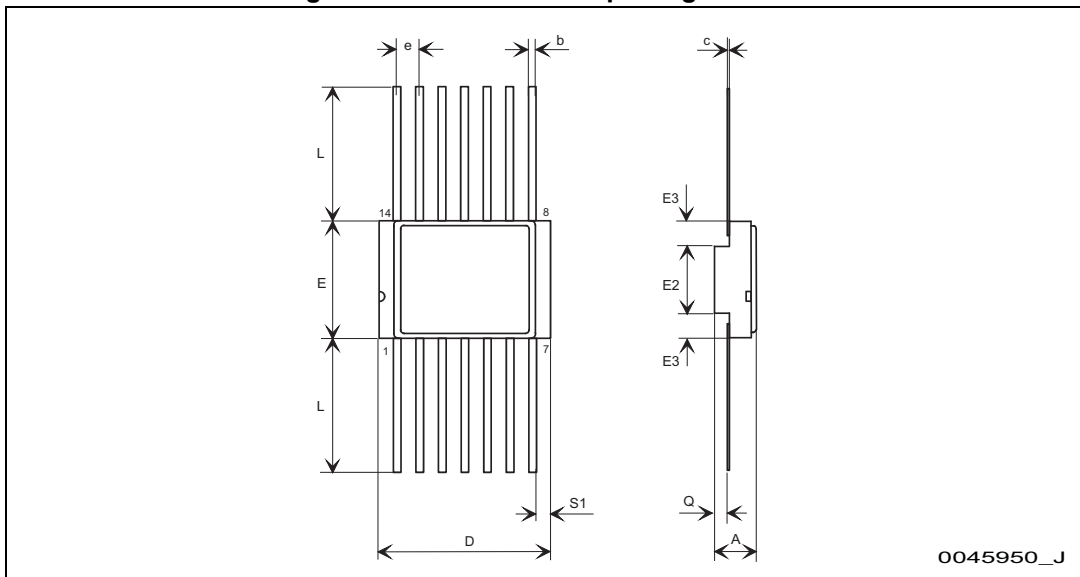

Note: The upper metallic lid is not electrically connected to any pins, nor to the IC die inside the package. Connecting unused pins or metal lid to ground or to the power supply will not affect the electrical characteristics.

Table 6. Ceramic Flat-14 (MIL-STD-1835) package mechanical data

Symbol	Dimensions (mm)			Dimensions (inches)		
	Min.	Typ.	Max.	Min.	Typ.	Max.
A	2.31		2.72	.091		.107
b	0.38		0.48	.015		.019
c	0.10		0.18	.004		.007
D	9.27		9.73	.365		.383
E	6.19		6.50	.244		.256
E2		3.68			.145	
E3	0.76			.030		
e		1.27			.050	
L	6.86		7.62	.250		.300
Q	0.66		1.14	.026		.045
S1	0.13			.005		

Figure 3. Ceramic DIL-14 package outline

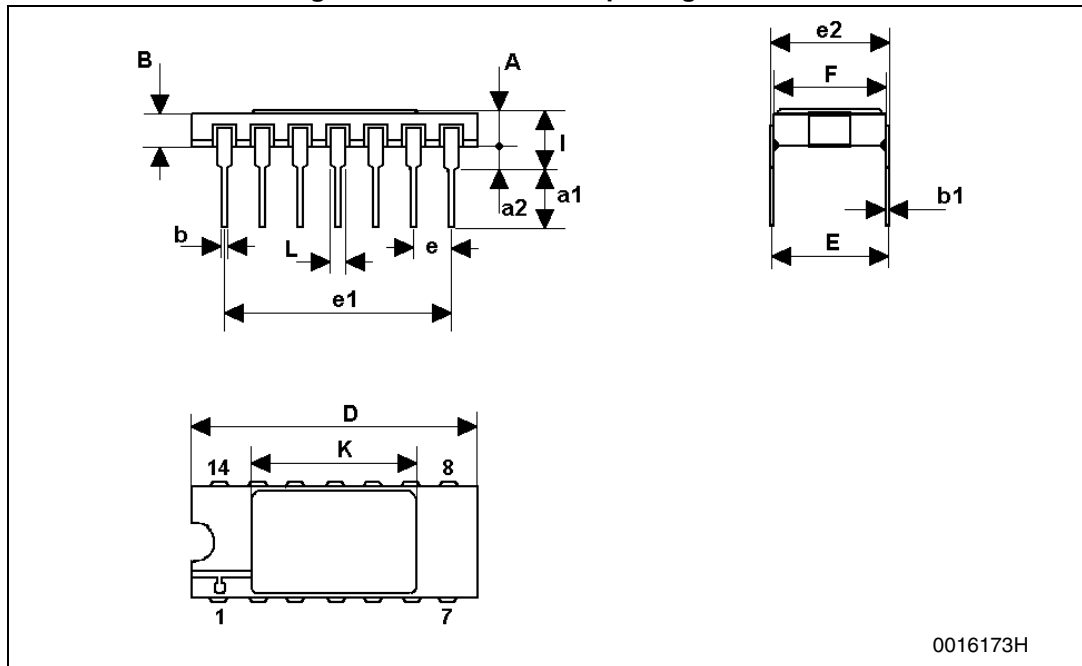

Note: The upper metallic lid is not electrically connected to any pins, nor to the IC die inside the package. Connecting unused pins or metal lid to ground or to the power supply will not affect the electrical characteristics.

Table 7. Ceramic DIL-14 (MIL-STD-1835) package mechanical data

Symbol	Dimensions (mm)			Dimensions (inches)		
	Min.	Typ.	Max.	Min.	Typ.	Max.
A	2.1		2.54	0.083		0.100
a1	3.00		3.70	0.118		0.146
a2	0.63	0.88	1.14	0.025	0.035	0.045
B	1.82	2.03	2.39	0.072	0.080	0.094
b	0.40	0.45	0.50	0.016	0.018	0.020
b1	0.20	0.254	0.30	0.008	0.010	0.012
D	18.79	19.00	19.20	0.740	0.748	0.756
E	7.36	7.62	7.87	0.290	0.300	0.310
e		2.54			0.100	
e1	15.11	15.24	15.37	0.595	0.600	0.605
e2	7.62	7.87	8.12	0.300	0.310	0.320
F	7.11		7.75	0.280		0.305
I			3.70			0.146
K	10.90		12.1	0.429		0.476
L	1.14	1.27	1.5	0.045	0.050	0.059

Figure 4. Ceramic Flat-16 package outline

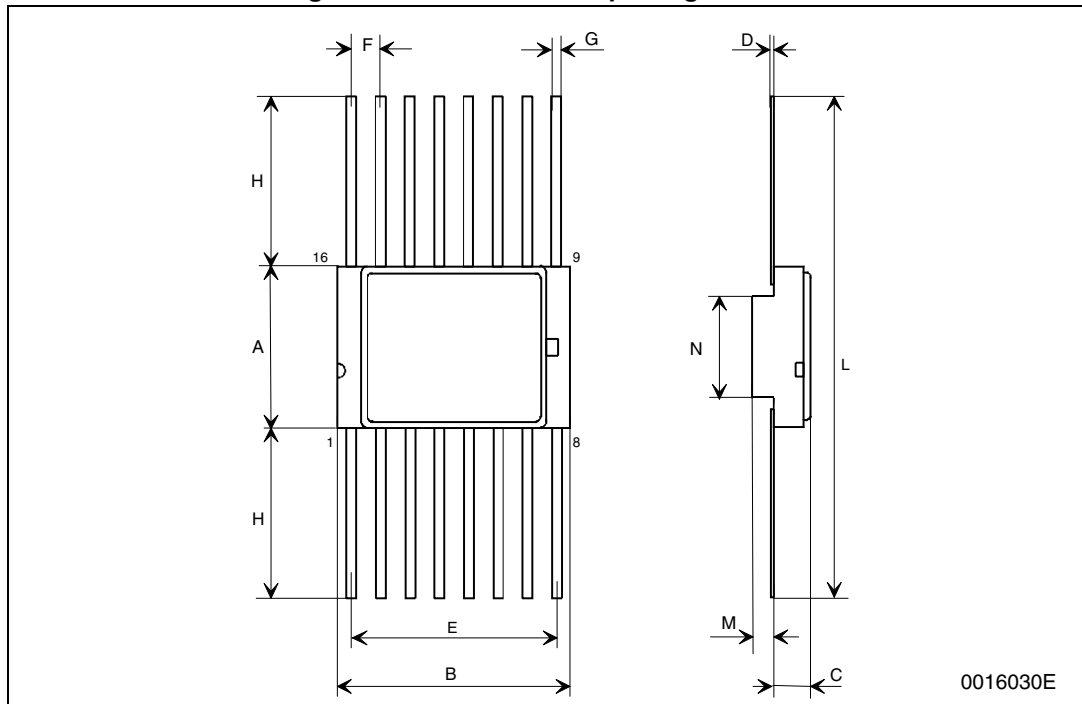

Note: The upper metallic lid is not electrically connected to any pins, nor to the IC die inside the package. Connecting unused pins or metal lid to ground or to the power supply will not affect the electrical characteristics.

Table 8. Ceramic Flat-16 (MIL-STD-1835) package mechanical data

Symbol	Dimensions (mm)			Dimensions (inches)		
	Min.	Typ.	Max.	Min.	Typ.	Max.
A	6.75	6.91	7.06	0.266	0.272	0.278
B	9.76	9.94	10.14	0.384	0.391	0.399
C	1.49		1.95	0.059		0.077
D	0.102	0.127	0.152	0.004	0.005	0.006
E	8.76	8.89	9.01	0.345	0.350	0.355
F		1.27			0.050	
G	0.38	0.43	0.48	0.015	0.017	0.019
H	6.0			0.236		
L	18.75		22.0	0.738		0.866
M	0.33	0.38	0.43	0.013	0.015	0.017
N		4.31			0.170	

Figure 5. Ceramic DIL-16 package outline

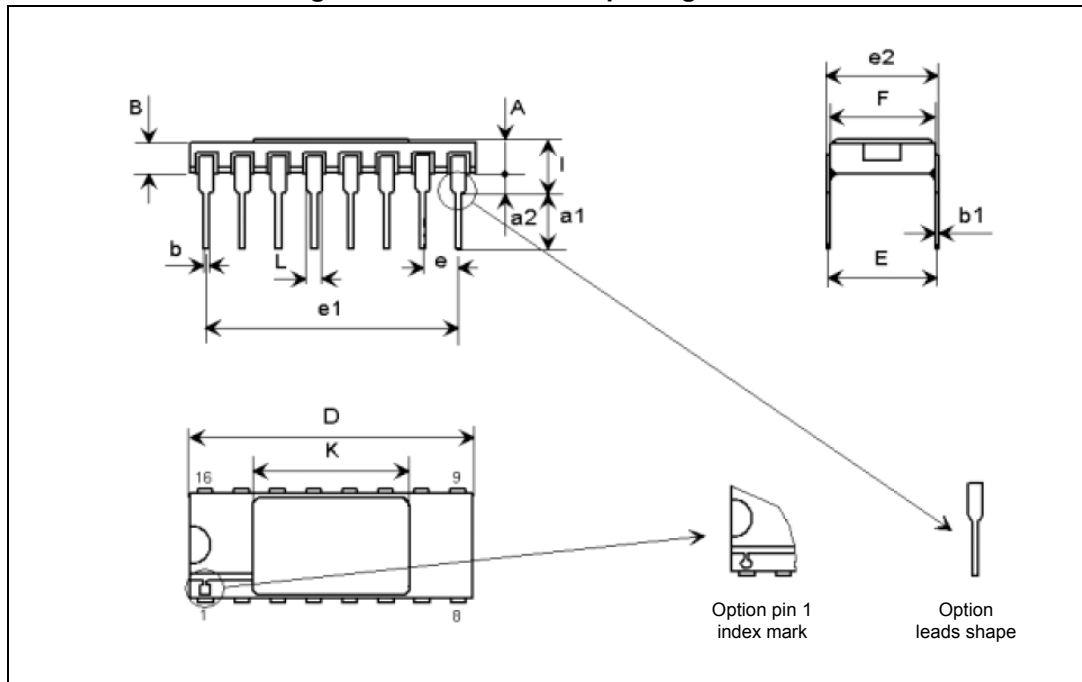

Note: The upper metallic lid is not electrically connected to any pins, nor to the IC die inside the package. Connecting unused pins or metal lid to ground or to the power supply will not affect the electrical characteristics.

Table 9. Ceramic DIL-16 (MIL-STD-1835) package mechanical data

Symbol	Dimensions (mm)			Dimensions (inches)		
	Min.	Typ.	Max.	Min.	Typ.	Max.
A	2.10		2.71	0.083		0.107
a1	3.00		3.70	0.118		0.146
a2	0.63	0.88	1.14	0.025	0.035	0.045
B	1.82		2.39	0.072		0.094
b	0.40	0.45	0.50	0.016	0.018	0.020
b1	0.20	0.254	0.30	0.008	0.010	0.012
D	20.06	20.32	20.58	0.790	0.800	0.810
E	7.36	7.62	7.87	0.290	0.300	0.310
e		2.54			0.100	
e1	17.65	17.78	17.90	0.695	0.700	0.705
e2	7.62	7.87	8.12	0.300	0.310	0.320
F	7.29	7.49	7.70	0.287	0.295	0.303
I			3.83			0.151
K	10.90		12.10	0.429		0.476
L	1.14		1.50	0.045		0.059

Figure 6. Ceramic Flat-20 package outline

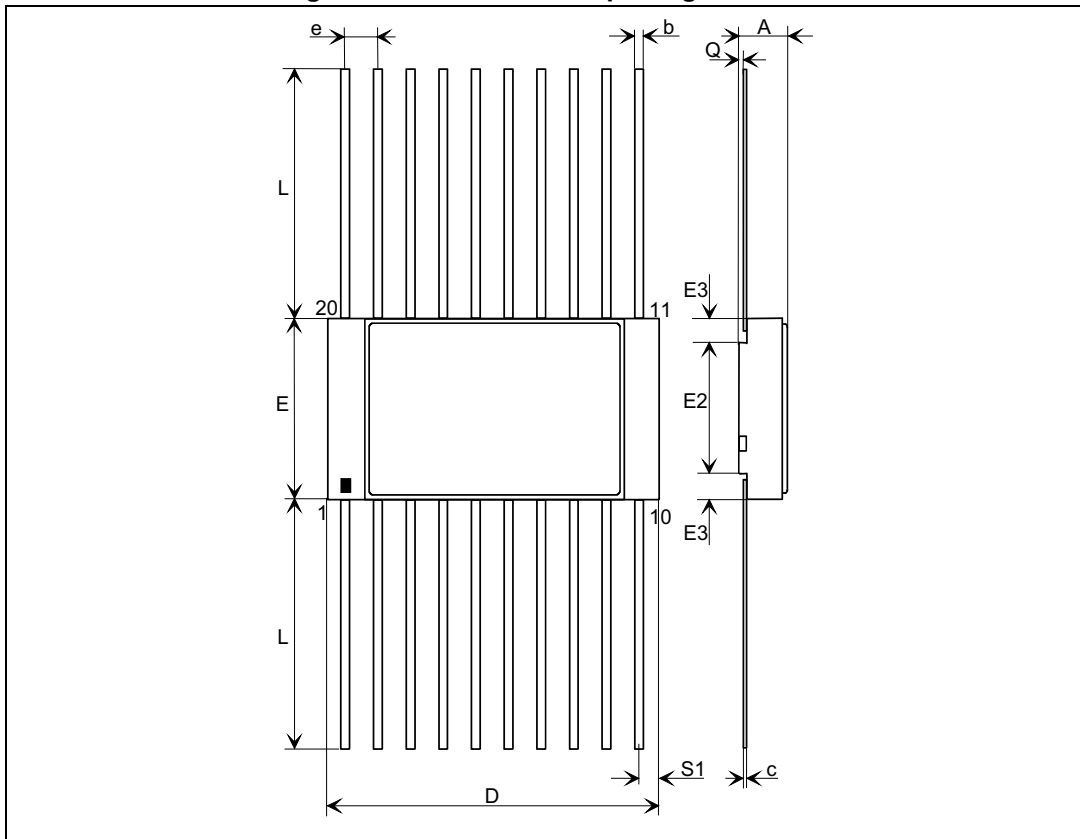

Note: The upper metallic lid is not electrically connected to any pins, nor to the IC die inside the package. Connecting unused pins or metal lid to ground or to the power supply will not affect the electrical characteristics.

Table 10. Ceramic Flat-20 package mechanical data

Symbol	Dimensions (mm)			Dimensions (inches)		
	Min.	Typ.	Max.	Min.	Typ.	Max.
A	1.91		2.21	0.075		0.087
b	0.38		0.48	0.015		0.019
c	0.076		0.152	0.003		0.006
D	12.83		13.08	0.505		0.515
E	6.99		7.24	0.275		0.285
E2	5.05	5.21	5.36	0.199	0.205	0.211
E3		0.95			0.037	
e	1.14		1.40	0.045		0.055
L	6.35		9.39	0.250		0.370
Q	0.25			0.010		
S1		0.55			0.022	

Figure 7. Ceramic DIL-20 package outline

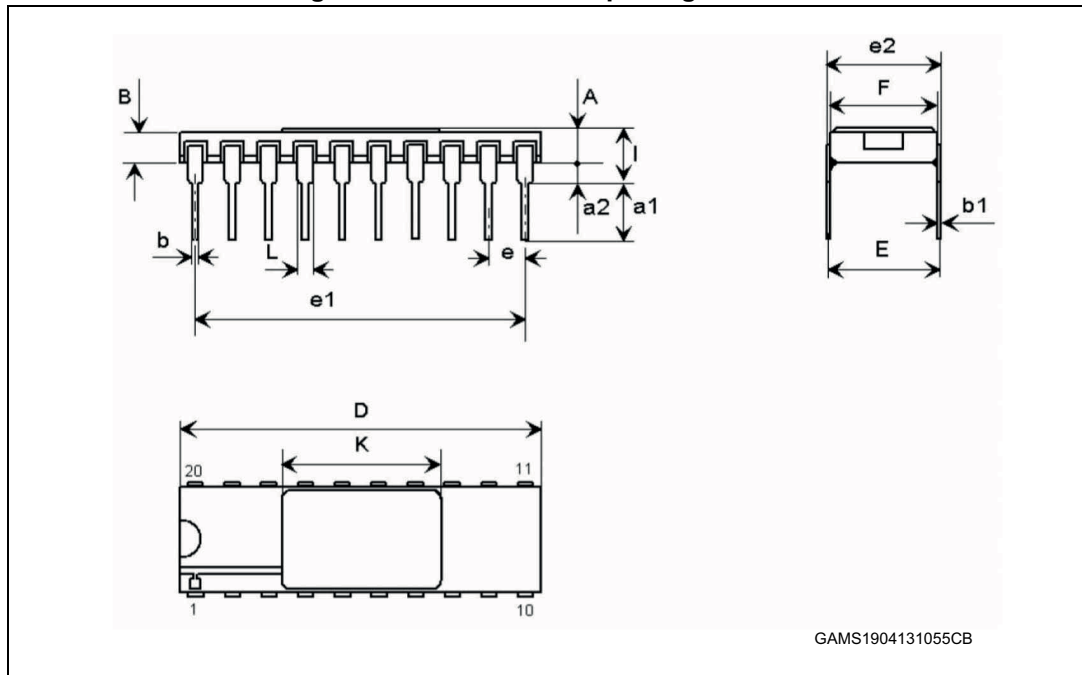

Note: The upper metallic lid is not electrically connected to any pins, nor to the IC die inside the package. Connecting unused pins or metal lid to ground or to the power supply will not affect the electrical characteristics.

Table 11. Ceramic DIL-20 (MIL-STD-1835) package mechanical data

Symbol	Dimensions (mm)			Dimensions (inches)		
	Min.	Typ.	Max.	Min.	Typ.	Max.
A	2.1		2.72	0.083		0.107
a1	3		3.7	0.118		0.146
a2	0.63	0.88	1.14	0.025	0.035	0.045
B	1.93	2.03	2.23	0.076	0.080	0.088
b	0.4	0.45	0.5	0.016	0.018	0.020
b1	0.2	0.254	0.3	0.008	0.010	0.012
D	25.14	25.4	25.65	0.990	1.000	1.010
E	7.36	7.62	7.87	0.290	0.300	0.310
e		2.54			0.100	
e1	22.73	22.86	22.99	0.895	0.900	0.905
e2	7.62	7.87	8.12	0.300	0.310	0.320
F	7.29	7.49	7.62	0.287	0.295	0.300
I			3.86			0.152
K	11.3		11.56	0.445		0.455
L	1.14	1.27	1.4	0.045	0.050	0.055

Figure 8. Ceramic Flat-48 package outline

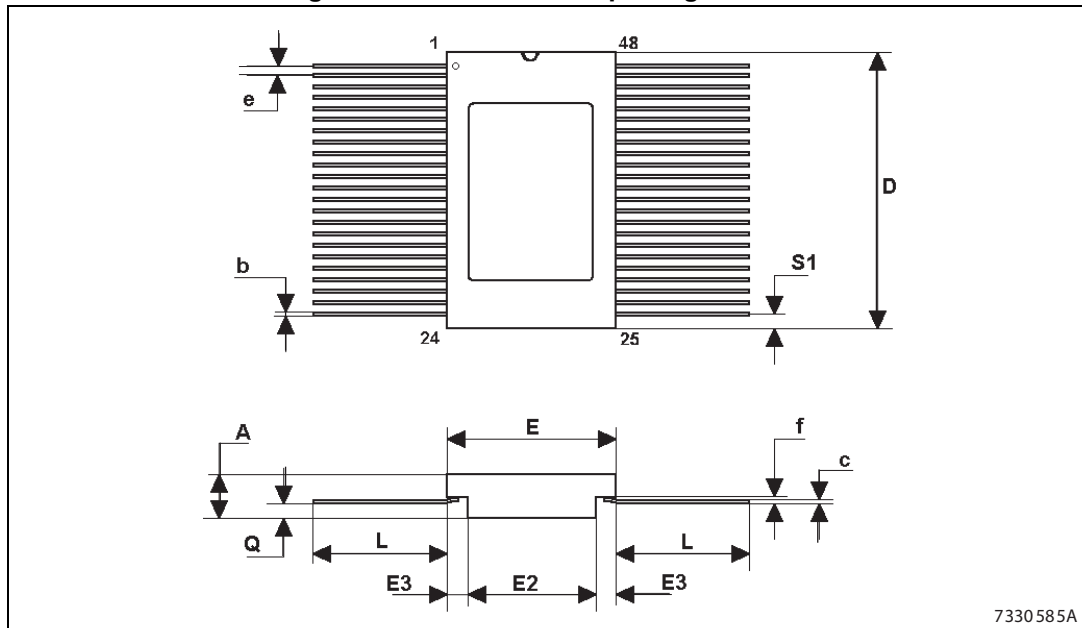

7330585A

Note: The upper metallic lid is not electrically connected to any pins, nor to the IC die inside the package. Connecting unused pins or metal lid to ground or to the power supply will not affect the electrical characteristics.

Table 12. Ceramic Flat-48 package mechanical data

Symbol	Dimensions (mm)			Dimensions (inches)		
	Min.	Typ.	Max.	Min.	Typ.	Max.
A	2.18	2.47	2.72	0.086	0.097	0.107
b	0.20	0.254	0.30	0.008	0.010	0.012
c	0.12	0.15	0.18	0.005	0.006	0.007
D	15.57	15.75	15.92	0.613	0.620	0.627
E	9.52	9.65	9.78	0.375	0.380	0.385
E2	6.22	6.35	6.48	0.245	0.250	0.255
E3	1.52	1.65	1.78	0.060	0.065	0.070
e		0.635			0.025	
f		0.20			0.008	
L	6.85	8.38	9.40	0.270	0.330	0.370
Q	0.66	0.79	0.92	0.026	0.031	0.036
S1	0.25	0.43	0.61	0.010	0.017	0.024



5 Ordering information

Table 13. Ordering information

Order codes	SMD pin	Quality level	Package	Lead finish	Marking ⁽¹⁾	Mass (g)	EPPL	Packing
RHFAC00K1	-	Engineering model	Flat-14	Gold	RHFAC00K1	0.70	-	Strip pack
RHFAC00K01V	5962F8754901VXC	QML-V flight	Flat-14	Gold	5962F8754901VXC	0.70	Y	
RHFAC00K02V	5962F8754901VXA	QML-V flight	Flat-14	Solder dip	5962F8754901VXA	0.70	Y	
RHFAC00D03V	5962F8754901VCC	QML-V flight	DIL-14	Gold	5962F8754901VCC	2.20	-	
RHFACT00K1	-	Engineering model	Flat-14	Gold	RHFACT00K1	0.70	-	
RHFACT00K01V	5962F8769903VXC	QML-V flight	Flat-14	Gold	5962F8769903VXC	0.70	Y	
RHFACT00K02V	5962F8769903VXA	QML-V flight	Flat-14	Solder dip	5962F8769903VXA	0.70	Y	
RHFACT00D03V	5962F8769903VCC	QML-V flight	DIL-14	Gold	5962F8769903VCC	2.20	-	
RHFAC02K1	-	Engineering model	Flat-14	Gold	RHFAC02K1	0.70	-	
RHFAC02K01V	5962F8761201VXC	QML-V flight	Flat-14	Gold	5962F8761201VXC	0.70	Y	
RHFAC02K02V	5962F8761201VXA	QML-V flight	Flat-14	Solder dip	5962F8761201VXA	0.70	Y	
RHFAC02D03V	5962F8761201VCC	QML-V flight	DIL-14	Gold	5962F8761201VCC	2.20	-	
RHFACT02K1	-	Engineering model	Flat-14	Gold	RHFACT02K1	0.70	-	
RHFACT02K01V	5962F8979101VXC	QML-V flight	Flat-14	Gold	5962F8979101VXC	0.70	-	
RHFACT02K02V	5962F8979101VXA	QML-V flight	Flat-14	Solder dip	5962F8979101VXA	0.70	-	
RHFAC04K1	-	Engineering model	Flat-14	Gold	RHFAC04K1	0.70	-	
RHFAC04K01V	5962F8760901VXC	QML-V flight	Flat-14	Gold	5962F8760901VXC	0.70	Y	
RHFAC04K02V	5962F8760901VXA	QML-V flight	Flat-14	Solder dip	5962F8760901VXA	0.70	Y	
RHFAC04D03V	5962F8760901VCC	QML-V flight	DIL-14	Gold	5962F8760901VCC	2.20	-	
RHFACT04K1	-	Engineering model	Flat-14	Gold	RHFACT04K1	0.70	-	
RHFACT04K01V	5962F8973403VXC	QML-V flight	Flat-14	Gold	5962F8973403VXC	0.70	-	
RHFACT04K02V	5962F8973403VXA	QML-V flight	Flat-14	Solder dip	5962F8973403VXA	0.70	-	

DocID17352 Rev 5

18/29

54ACxxxx, 54ACTxxxx

Ordering information



Table 13. Ordering information (continued)

Order codes	SMD pin	Quality level	Package	Lead finish	Marking ⁽¹⁾	Mass (g)	EPPL	Packing
RHFACT04D03V	5962F8973403VCC	QML-V flight	DIL-14	Gold	5962F8973403VCC	2.20	-	Strip pack
RHFAC08K1	-	Engineering model	Flat-14	Gold	RHFAC08K1	0.70	-	
RHFAC08K01V	5962F8761501VXC	QML-V flight	Flat-14	Gold	5962F8761501VXC	0.70	Y	
RHFAC08K02V	5962F8761501VXA	QML-V flight	Flat-14	Solder dip	5962F8761501VXA	0.70	Y	
RHFAC08D03V	5962F8761501VCC	QML-V flight	DIL-14	Gold	5962F8761501VCC	2.20	-	
RHFACT08K1	-	Engineering model	Flat-14	Gold	RHFACT08K1	0.70	-	
RHFACT08K01V	5962F8954703VXC	QML-V flight	Flat-14	Gold	5962F8954703VXC	0.70	-	
RHFACT08K02V	5962F8954703VXA	QML-V flight	Flat-14	Solder dip	5962F8954703VXA	0.70	-	
RHFACT08D03V	5962F8954703VCC	QML-V flight	DIL-14	Gold	5962F8954703VCC	2.20	-	
RHFAC10K1	-	Engineering model	Flat-14	Gold	RHFAC10K1	0.70	-	
RHFAC10K01V	5962F8761001VXC	QML-V flight	Flat-14	Gold	5962F8761001VXC	0.70	Y	
RHFAC10K02V	5962F8761001VXA	QML-V flight	Flat-14	Solder dip	5962F8761001VXA	0.70	Y	
RHFAC10D03V	5962F8761001VCC	QML-V flight	DIL-14	Gold	5962F8761001VCC	2.20	-	
RHFACT10K1	-	Engineering model	Flat-14	Gold	RHFACT10K1	0.70	-	
RHFACT10K01V	5962F9218202VXC	QML-V flight	Flat-14	Gold	5962F9218202VXC	0.70	-	
RHFACT10K02V	5962F9218202VXA	QML-V flight	Flat-14	Solder dip	5962F9218202VXA	0.70	-	
RHFAC11K1	-	Engineering model	Flat-14	Gold	RHFAC11K1	0.70	-	
RHFAC11K01V	5962F8761101VXC	QML-V flight	Flat-14	Gold	5962F8761101VXC	0.70	Y	
RHFAC11K02V	5962F8761101VXA	QML-V flight	Flat-14	Solder dip	5962F8761101VXA	0.70	Y	
RHFAC11D03V	5962F8761101VCC	QML-V flight	DIL-14	Gold	5962F8761101VCC	2.20	-	
RHFACT11K1	-	Engineering model	Flat-14	Gold	RHFACT11K1	0.70	-	
RHFACT11K01V	5962F9077202VXC	QML-V flight	Flat-14	Gold	5962F9077202VXC	0.70	-	
RHFACT11K02V	5962F9077202VXA	QML-V flight	Flat-14	Solder dip	5962F9077202VXA	0.70	-	
RHFAC14K1	-	Engineering model	Flat-14	Gold	RHFAC14K1	0.70	-	
RHFAC14K01V	5962F8762401VXC	QML-V flight	Flat-14	Gold	5962F8762401VXC	0.70	Y	

**Table 13. Ordering information (continued)**

Order codes	SMD pin	Quality level	Package	Lead finish	Marking ⁽¹⁾	Mass (g)	EPPL	Packing
RHFAC14K02V	5962F8762401VXA	QML-V flight	Flat-14	Solder dip	5962F8762401VXA	0.70	Y	Strip pack
RHFAC14D03V	5962F8762401VCC	QML-V flight	DIL-14	Gold	5962F8762401VCC	2.20	-	
RHFAC14D04V	5962F8762401VCA	QML-V flight	DIL-14	Solder dip	5962F8762401VCA	2.20	-	
RHFAC14AK1	-	Engineering model	Flat-14	Gold	RHFAC14AK1	0.70	-	
RHFAC14AK01V	5962F8762403VXC	QML-V flight	Flat-14	Gold	5962F8762403VXC	0.70	-	
RHFAC14AK02V	5962F8762403VXA	QML-V flight	Flat-14	Solder dip	5962F8762403VXA	0.70	-	
RHFACT14K1	-	Engineering model	Flat-14	Gold	RHFACT14K1	0.70	-	
RHFACT14K01V	5962F9681301VXC	QML-V flight	Flat-14	Gold	5962F9681301VXC	0.70	-	
RHFACT14K02V	5962F9681301VXA	QML-V flight	Flat-14	Solder dip	5962F9681301VXA	0.70	-	
RHFAC32K1	-	Engineering model	Flat-14	Gold	RHFAC32K1	0.70	-	
RHFAC32K01V	5962F8761401VXC	QML-V flight	Flat-14	Gold	5962F8761401VXC	0.70	Y	
RHFAC32K02V	5962F8761401VXA	QML-V flight	Flat-14	Solder dip	5962F8761401VXA	0.70	Y	
RHFAC32D03V	5962F8761401VCC	QML-V flight	DIL-14	Gold	5962F8761401VCC	2.20	-	
RHFACT32K1	-	Engineering model	Flat-14	Gold	RHFACT32K1	0.70	-	
RHFACT32K01V	5962F8973603VXC	QML-V flight	Flat-14	Gold	5962F8973603VXC	0.70	-	
RHFACT32K02V	5962F8973603VXA	QML-V flight	Flat-14	Solder dip	5962F8973603VXA	0.70	-	
RHFACT32D03V	5962F8973603VCC	QML-V flight	DIL-14	Gold	5962F8973603VCC	2.20	-	
RHFAC74K1	-	Engineering model	Flat-14	Gold	RHFAC74K1	0.70	-	
RHFAC74K01V	5962F8852003VXC	QML-V flight	Flat-14	Gold	5962F8852003VXC	0.70	Y	
RHFAC74K02V	5962F8852003VXA	QML-V flight	Flat-14	Solder dip	5962F8852003VXA	0.70	Y	
RHFAC74D03V	5962F8852003VCC	QML-V flight	DIL-14	Gold	5962F8852003VCC	2.20	-	
RHFACT74K1	-	Engineering model	Flat-14	Gold	RHFACT74K1	0.70	-	
RHFACT74K01V	5962F87525 03VXC	QML-V flight	Flat-14	Gold	5962F87525 03VXC	0.70	-	
RHFACT74K02V	5962F87525 03VXA	QML-V flight	Flat-14	Solder dip	5962F87525 03VXA	0.70	-	
RHFACT74D03V	5962F87525 03VCC	QML-V flight	DIL-14	Gold	5962F87525 03VCC	2.20	-	

DocID17352 Rev 5

2012/9

54ACxxxx, 54ACTxxxx

Ordering information

**Table 13. Ordering information (continued)**

Order codes	SMD pin	Quality level	Package	Lead finish	Marking ⁽¹⁾	Mass (g)	EPPL	Packing
RHFAC86K1	-	Engineering model	Flat-14	Gold	RHFAC86K1	0.70	-	Strip pack
RHFAC86K01V	5962F8955001VXC	QML-V flight	Flat-14	Gold	5962F8955001VXC	0.70	Y	
RHFAC86K02V	5962F8955001VXA	QML-V flight	Flat-14	Solder dip	5962F8955001VXA	0.70	Y	
RHFAC86D03V	5962F8955001VCC	QML-V flight	DIL-14	Gold	5962F8955001VCC	2.20	-	
RHFACT86K1	-	Engineering model	Flat-14	Gold	RHFACT86K1	0.70	-	
RHFACT86K01V	5962F9068702VXC	QML-V flight	Flat-14	Gold	5962F9068702VXC	0.70	Y	
RHFACT86K02V	5962F9068702VXA	QML-V flight	Flat-14	Solder dip	5962F9068702VXA	0.70	Y	
RHFAC138K1	-	Engineering model	Flat-16	Gold	RHFAC138K1	0.70	-	
RHFAC138K01V	5962F8762201VXC	QML-V flight	Flat-16	Gold	5962F8762201VXC	0.70	Y	
RHFAC138K02V	5962F8762201VXA	QML-V flight	Flat-16	Solder dip	5962F8762201VXA	0.70	Y	
RHFAC138D03V	5962F8762201VEC	QML-V flight	DIL-16	Gold	5962F8762201VEC	2.20	-	
RHFACT138K1	-	Engineering model	Flat-16	Gold	RHFACT138K1	0.70	-	
RHFACT138K01V	5962F8755403VXC	QML-V flight	Flat-16	Gold	5962F8755403VXC	0.70	-	
RHFACT138K02V	5962F8755403VXA	QML-V flight	Flat-16	Solder dip	5962F8755403VXA	0.70	-	
RHFAC139K1	-	Engineering model	Flat-16	Gold	RHFAC139K1	0.70	-	
RHFAC139K01V	5962F8762301VXC	QML-V flight	Flat-16	Gold	5962F8762301VXC	0.70	Y	
RHFAC139K02V	5962F8762301VXA	QML-V flight	Flat-16	Solder dip	5962F8762301VXA	0.70	Y	
RHFACT139K1	-	Engineering model	Flat-16	Gold	RHFACT139K1	0.70	-	
RHFACT139K01V	5962F8755302VXC	QML-V flight	Flat-16	Gold	5962F8755302VXC	0.70	-	
RHFACT139K02V	5962F8755302VXA	QML-V flight	Flat-16	Solder dip	5962F8755302VXA	0.70	-	
RHFACT139D03V	5962F8755302VEC	QML-V flight	DIL-16	Gold	5962F8755302VEC	2.20	-	
RHFAC151K1	-	Engineering model	Flat-16	Gold	RHFAC151K1	0.70	-	
RHFAC151K01V	5962F8769102VXC	QML-V flight	Flat-16	Gold	5962F8769102VXC	0.70	-	
RHFAC151K02V	5962F8769102VXA	QML-V flight	Flat-16	Solder dip	5962F8769102VXA	0.70	-	
RHFACT151K1	-	Engineering model	Flat-16	Gold	RHFACT151K1	0.70	-	

**Table 13. Ordering information (continued)**

Order codes	SMD pin	Quality level	Package	Lead finish	Marking ⁽¹⁾	Mass (g)	EPPL	Packing
RHFACT151K01V	5962F8875602VXC	QML-V flight	Flat-16	Gold	5962F8875602VXC	0.70	-	Strip pack
RHFACT151K02V	5962F8875602VXA	QML-V flight	Flat-16	Solder dip	5962F8875602VXA	0.70	-	
RHFAC157K1	-	Engineering model	Flat-16	Gold	RHFAC157K1	0.70	-	
RHFAC157K01V	5962F8953901VXC	QML-V flight	Flat-16	Gold	5962F8953901VXC	0.70	Y	
RHFAC157K02V	5962F8953901VXA	QML-V flight	Flat-16	Solder dip	5962F8953901VXA	0.70	Y	
RHFAC157D03V	5962F8953901VEC	QML-V flight	DIL-16	Gold	5962F8953901VEC	2.20	-	
RHFACT157K1	-	Engineering model	Flat-16	Gold	RHFACT157K1	0.70	-	
RHFACT157K01V	5962F8968802VXC	QML-V flight	Flat-16	Gold	5962F8968802VXC	0.70	-	
RHFACT157K02V	5962F8968802VXA	QML-V flight	Flat-16	Solder dip	5962F8968802VXA	0.70	-	
RHFACT157D03V	5962F8968802VEC	QML-V flight	DIL-16	Gold	5962F8968802VEC	2.20	-	
RHFAC161K1	-	Engineering model	Flat-16	Gold	RHFAC161K1	0.70	-	
RHFAC161K01V	5962F8956101VXC	QML-V flight	Flat-16	Gold	5962F8956101VXC	0.70	Y	
RHFAC161K02V	5962F8956101VXA	QML-V flight	Flat-16	Solder dip	5962F8956101VXA	0.70	Y	
RHFAC161D03V	5962F8956101VEC	QML-V flight	DIL-16	Gold	5962F8956101VEC	2.20	-	
RHFACT161K1	-	Engineering model	Flat-16	Gold	RHFACT161K1	0.70	-	
RHFACT161K01V	5962F9172202VXC	QML-V flight	Flat-16	Gold	5962F9172202VXC	0.70	-	
RHFACT161K02V	5962F9172202VXA	QML-V flight	Flat-16	Solder dip	5962F9172202VXA	0.70	-	
RHFAC174K1	-	Engineering model	Flat-16	Gold	RHFAC174K1	0.70	-	
RHFAC174K01V	5962F8762602VXC	QML-V flight	Flat-16	Gold	5962F8762602VXC	0.70	-	
RHFAC174K02V	5962F8762602VXA	QML-V flight	Flat-16	Solder dip	5962F8762602VXA	0.70	-	
RHFACT174K1	-	Engineering model	Flat-16	Gold	RHFACT174K1	0.70	-	
RHFACT174K01V	5962F8775702VXC	QML-V flight	Flat-16	Gold	5962F8775702VXC	0.70	-	
RHFACT174K02V	5962F8775702VXA	QML-V flight	Flat-16	Solder dip	5962F8775702VXA	0.70	-	
RHFAC191K1	-	Engineering model	Flat-16	Gold	RHFAC191K1	0.70	-	
RHFAC191K01V	5962F8974902VXC	QML-V flight	Flat-16	Gold	5962F8974902VXC	0.70	-	

DocID17352 Rev 5

22/29

54ACxxxx, 54ACTxxxx

Ordering information

**Table 13. Ordering information (continued)**

Order codes	SMD pin	Quality level	Package	Lead finish	Marking ⁽¹⁾	Mass (g)	EPPL	Packing
RHFAC191K02V	5962F8974902VXA	QML-V flight	Flat-16	Solder dip	5962F8974902VXA	0.70	-	Strip pack
RHFAC191D03V	5962F8974902VEC	QML-V flight	DIL-16	Gold	5962F8974902VEC	2.20	-	
RHFACT191K1	-	Engineering model	Flat-16	Gold	RHFACT191K1	0.70	-	
RHFACT191K01V	5962F0422801VXC	QML-V flight	Flat-16	Gold	5962F0422801VXC	0.70	-	
RHFACT191K02V	5962F0422801VXA	QML-V flight	Flat-16	Solder dip	5962F0422801VXA	0.70	-	
RHFAC240K1	-	Engineering model	Flat-20	Gold	RHFAC240K1	0.90	-	
RHFAC240K01V	5962F8755001VXC	QML-V flight	Flat-20	Gold	5962F8755001VXC	0.90	Y	
RHFAC240K02V	5962F8755001VXA	QML-V flight	Flat-20	Solder dip	5962F8755001VXA	0.90	Y	
RHFACT240K1	-	Engineering model	Flat-20	Gold	RHFACT240K1	0.90	-	
RHFACT240K01V	5962F8775903VXC	QML-V flight	Flat-20	Gold	5962F8775903VXC	0.90	Y	
RHFACT240K02V	5962F8775903VXA	QML-V flight	Flat-20	Solder dip	5962F8775903VXA	0.90	Y	
RHFAC244K1	-	Engineering model	Flat-20	Gold	RHFAC244K1	0.90	-	
RHFAC244K01V	5962F8755201VXC	QML-V flight	Flat-20	Gold	5962F8755201VXC	0.90	Y	
RHFAC244K02V	5962F8755201VXA	QML-V flight	Flat-20	Solder dip	5962F8755201VXA	0.90	Y	
RHFACT244K1	-	Engineering model	Flat-20	Gold	RHFACT244K1	0.90	-	
RHFACT244K01V	5962F8776003VXC	QML-V flight	Flat-20	Gold	5962F8776003VXC	0.90	Y	
RHFACT244K02V	5962F8776003VXA	QML-V flight	Flat-20	Solder dip	5962F8776003VXA	0.90	Y	
RHFAC245K1	-	Engineering model	Flat-20	Gold	RHFAC245K1	0.90	-	
RHFAC245K01V	5962F8775802VXC	QML-V flight	Flat-20	Gold	5962F8775802VXC	0.90	Y	
RHFAC245K02V	5962F8775802VXA	QML-V flight	Flat-20	Solder dip	5962F8775802VXA	0.90	Y	
RHFACT245K1	-	Engineering model	Flat-20	Gold	RHFACT245K1	0.90	-	
RHFACT245K01V	5962F8766303VXC	QML-V flight	Flat-20	Gold	5962F8766303VXC	0.90	Y	
RHFACT245K02V	5962F8766303VXA	QML-V flight	Flat-20	Solder dip	5962F8766303VXA	0.90	Y	
RHFAC273K1	-	Engineering model	Flat-20	Gold	RHFAC273K1	0.90	-	
RHFAC273K01V	5962F8775601VXC	QML-V flight	Flat-20	Gold	5962F8775601VXC	0.90	Y	

**Table 13. Ordering information (continued)**

Order codes	SMD pin	Quality level	Package	Lead finish	Marking ⁽¹⁾	Mass (g)	EPPL	Packing
RHFAC273K02V	5962F8775601VXA	QML-V flight	Flat-20	Solder dip	5962F8775601VXA	0.90	Y	Strip pack
RHFACT273K1	-	Engineering model	Flat-20	Gold	RHFACT273K1	0.90	-	
RHFACT273K01V	5962F0152701VXC	QML-V flight	Flat-20	Gold	5962F0152701VXC	0.90	-	
RHFACT273K02V	5962F0152701VXA	QML-V flight	Flat-20	Solder dip	5962F0152701VXA	0.90	-	
RHFAC373K1	-	Engineering model	Flat-20	Gold	RHFAC373K1	0.90	-	
RHFAC373K01V	5962F8755501VXC	QML-V flight	Flat-20	Gold	5962F8755501VXC	0.90	Y	
RHFAC373K02V	5962F8755501VXA	QML-V flight	Flat-20	Solder dip	5962F8755501VXA	0.90	Y	
RHFACT373K1	-	Engineering model	Flat-20	Gold	RHFACT373K1	0.90	-	
RHFACT373K01V	5962F8755603VXC	QML-V flight	Flat-20	Gold	5962F8755603VXC	0.90	-	
RHFACT373K02V	5962F8755603VXA	QML-V flight	Flat-20	Solder dip	5962F8755603VXA	0.90	-	
RHFAC374K1	-	Engineering model	Flat-20	Gold	RHFAC374K1	0.90	-	
RHFAC374K01V	5962F8769401VXC	QML-V flight	Flat-20	Gold	5962F8769401VXC	0.90	Y	
RHFAC374K02V	5962F8769401VXA	QML-V flight	Flat-20	Solder dip	5962F8769401VXA	0.90	Y	
RHFACT374K1	-	Engineering model	Flat-20	Gold	RHFACT374K1	0.90	-	
RHFACT374K01V	5962F8763103VXC	QML-V flight	Flat-20	Gold	5962F8763103VXC	0.90	-	
RHFACT374K02V	5962F8763103VXA	QML-V flight	Flat-20	Solder dip	5962F8763103VXA	0.90	-	
RHFAC521K1	-	Engineering model	Flat-20	Gold	RHFAC521K1	0.90	-	
RHFAC521K01V	-	QML-V flight	Flat-20	Gold		0.90	-	
RHFAC521K02V	-	QML-V flight	Flat-20	Solder dip		0.90	-	
RHFAC540K1	-	Engineering model	Flat-20	Gold	RHFAC540K1	0.90	-	
RHFAC540K01V	-	QML-V flight	Flat-20	Gold		0.90	-	
RHFAC540K02V	-	QML-V flight	Flat-20	Solder dip		0.90	-	
RHFAC541K1	-	Engineering model	Flat-20	Gold	RHFAC541K1	0.90	-	
RHFAC541K01V	5962F8870601VXC	QML-V flight	Flat-20	Gold	5962F8870601VXC	0.90	Y	
RHFAC541K02V	5962F8870601VXA	QML-V flight	Flat-20	Solder dip	5962F8870601VXA	0.90	Y	



Table 13. Ordering information (continued)

Order codes	SMD pin	Quality level	Package	Lead finish	Marking ⁽¹⁾	Mass (g)	EPPL	Packing
RHFACT541K1	-	Engineering model	Flat-20	Gold	RHFACT541K1	0.90	-	Strip pack
RHFACT541K01V	5962F8979502VXC	QML-V flight	Flat-20	Gold	5962F8979502VXC	0.90	-	
RHFACT541K02V	5962F8979502VXA	QML-V flight	Flat-20	Solder dip	5962F8979502VXA	0.90	-	
RHFAC574K1	-	Engineering model	Flat-20	Gold	RHFAC574K1	0.90	-	
RHFAC574K01V	5962F9677302VXC	QML-V flight	Flat-20	Gold	5962F9677302VXC	0.90	-	
RHFAC574K02V	5962F9677302VXA	QML-V flight	Flat-20	Solder dip	5962F9677302VXA	0.90	-	
RHFACT574K1	-	Engineering model	Flat-20	Gold	RHFACT574K1	0.90	-	
RHFACT574K01V	5962F8960102VXC	QML-V flight	Flat-20	Gold	5962F8960102VXC	0.90	Y	
RHFACT574K02V	5962F8960102VXA	QML-V flight	Flat-20	Solder dip	5962F8960102VXA	0.90	Y	
RHFAC2525K1	-	Engineering model	Flat-14	Gold	RHFAC2525K1	1.50	-	
RHFAC2525K01V	5962F9217402VXC	QML-V flight	Flat-14	Gold	5962F9217402VXC	1.50	-	
RHFAC2525K02V	5962F9217402VXA	QML-V flight	Flat-14	Solder dip	5962F9217402VXA	1.50	-	
RHFAC16244K1	-	Engineering model	Flat-48	Gold	RHFAC16244K1	1.50	-	
RHFAC16244K01V	5962F0421001VXC	QML-V flight	Flat-48	Gold	5962F0421001VXC	1.50	Y	
RHFAC16244K02V	5962F0421001VXA	QML-V flight	Flat-48	Solder dip	5962F0421001VXA	1.50	Y	
RHFACT16244K1	-	Engineering model	Flat-48	Gold	RHFACT16244K1	1.50	-	
RHFACT16244K01V	5962F9202202VYC	QML-V flight	Flat-48	Gold	5962F9202202VYC	1.50	-	
RHFACT16244K02V	5962F9202202VYA	QML-V flight	Flat-48	Solder dip	5962F9202202VYA	1.50	-	
RHFAC16245K1	-	Engineering model	Flat-48	Gold	RHFAC16245K1	1.50	-	
RHFAC16245K01V	5962F0421101VXC	QML-V flight	Flat-48	Gold	5962F0421101VXC	1.50	-	
RHFAC16245K02V	5962F0421101VXA	QML-V flight	Flat-48	Solder dip	5962F0421101VXA	1.50	-	
RHFACT16245K1	-	Engineering model	Flat-48	Gold	RHFACT16245K1	1.50	-	
RHFACT16245K01V	5962F9202302VYC	QML-V flight	Flat-48	Gold	5962F9202302VYC	1.50	-	
RHFACT16245K02V	5962F9202302VYA	QML-V flight	Flat-48	Solder dip	5962F9202302VYA	1.50	-	
RHFAC16373K1	-	Engineering model	Flat-48	Gold	RHFAC16373K1	1.50	-	

**Table 13. Ordering information (continued)**

Order codes	SMD pin	Quality level	Package	Lead finish	Marking ⁽¹⁾	Mass (g)	EPPL	Packing
RHFAC16373K01V	5962F0421201VXC	QML-V flight	Flat-48	Gold	5962F0421201VXC	1.50	-	Strip pack
RHFAC16373K02V	5962F0421201VXA	QML-V flight	Flat-48	Solder dip	5962F0421201VXA	1.50	-	
RHFACT16373K1	-	Engineering model	Flat-48	Gold	RHFACT16373K1	1.50	-	
RHFACT16373K01V	5962F9202402VYC	QML-V flight	Flat-48	Gold	5962F9202402VYC	1.50	-	
RHFACT16373K02V	5962F9202402VYA	QML-V flight	Flat-48	Solder dip	5962F9202402VYA	1.50	-	
RHFAC16374K1	-	Engineering model	Flat-48	Gold	RHFAC16374K1	1.50	-	
RHFAC16374K01V	5962F0421301VXC	QML-V flight	Flat-48	Gold	5962F0421301VXC	1.50	-	
RHFAC16374K02V	5962F0421301VXA	QML-V flight	Flat-48	Solder dip	5962F0421301VXA	1.50	-	
RHFACT16374K1	-	Engineering model	Flat-48	Gold	RHFACT16374K1	1.50	-	
RHFACT16374K01V	5962F9202502VYC	QML-V flight	Flat-48	Gold	5962F9202502VYC	1.50	-	
RHFACT16374K02V	5962F9202502VYA	QML-V flight	Flat-48	Solder dip	5962F9202502VYA	1.50	-	
RHRAC164245K1	-	Engineering model	Flat-48	Gold	RHFAC164245K1	1.50	-	
RHRAC164245K01V	5962R9858008VYC	QML-V flight	Flat-48	Gold	5962R9858008VYC	1.50	-	

1. Specific marking only. Complete marking includes the following:
- SMD pin (as indicated in above table)
 - ST logo
 - Date code (date the package was sealed) in YYWWA (year, week, and lot index of week)
 - QML logo (Q or V)
 - Country of origin (FR = France)

Note: Contact an ST sales office for information about the specific conditions for other 54AC or 54ACT series part numbers, products in die form, and QML-Q versions.

6 Other information

6.1 Date code

The date code is structured as shown below:

- EM xyywwz
- QML-V yywwz

where:

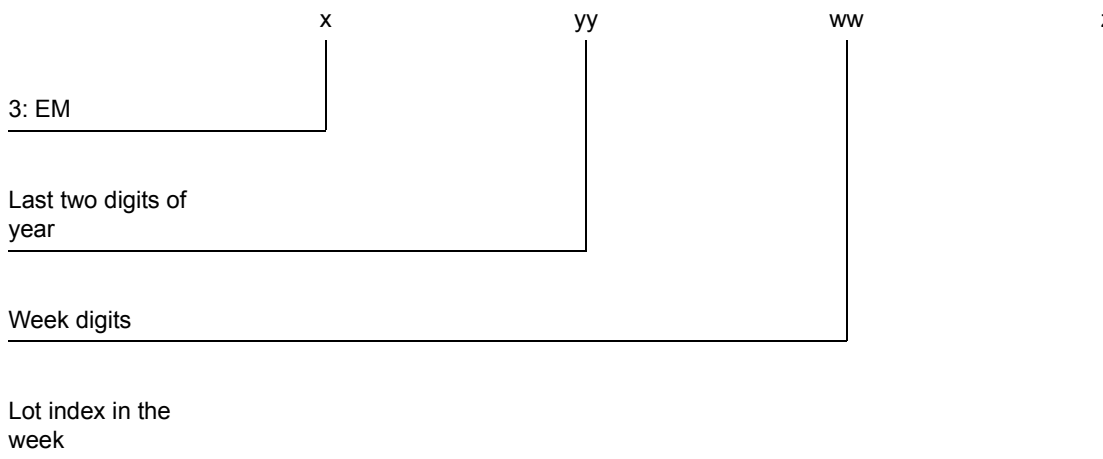

6.2 Documentation

Table 14. Documentation provided for QML-V flight

Quality level	Documentation
Engineering model	Certificate of conformance QCI ⁽¹⁾ (groups A, B, C, D, and E) Screening electrical data
QML-V flight	Certificate of conformance QCI ⁽¹⁾ (groups A, B, C, D, and E) Screening electrical data Precap report PIND ⁽²⁾ test SEM ⁽³⁾ inspection report X-Ray report

1. QCI = quality conformance inspection
2. PIND = particle impact noise detection
3. SEM = scanning electron microscope

7 Revision history

Table 15. Document revision history

Date	Revision	Changes
06-Apr-2010	1	Initial release. The information in this data brief was previously published in a datasheet (document ID 17145).
02-Aug-2011	2	Added <i>Note: on page 11</i> , <i>Note: on page 12</i> , <i>Note: on page 13</i> , <i>Note: on page 14</i> , <i>Note: on page 15</i> , <i>Note: on page 15</i> , <i>Note: on page 17</i> and in the "Pin connections" diagram on the coverpage
23-Apr-2012	3	Updated drawing Flat-20 on the coverpage, added list of tables and figures, updated title of <i>Table 4</i> and <i>Table 5</i> , reformatted <i>Section 4: Package mechanical data</i> and updated titles of <i>Figure 2</i> to <i>8</i> and titles and headers of <i>Table 6</i> to <i>12</i> , updated data of <i>Table 10</i> and <i>Table 12</i> , minor text corrections throughout document.
23-May-2013	4	Updated operating voltage in <i>Features</i> Updated <i>Table 1: Device summary</i> , <i>Table 6</i> , <i>Table 7</i> , <i>Table 8</i> , <i>Table 9</i> , <i>Table 10</i> , <i>Table 11</i> , <i>Table 12</i> , and <i>Table 13: Ordering information</i> . Added <i>Section 6: Other information</i>
09-Apr-2014	5	Updated ceramic Flat-14 package in <i>Figure 2</i> and <i>Table 6</i> Specified MIL-STD-1835 for Flat 14 (<i>Table 6</i>), DIL 14 (<i>Table 7</i>), Flat 16 (<i>Table 8</i>), DIL 16 (<i>Table 9</i>) and DIL 20 (<i>Table 11</i>) packages Removed "DSCC" from ceramic Flat-20 package (<i>Figure 6</i> and <i>Figure 10</i>) Replaced "ESCC" with "QML-V" in title of <i>Table 14</i>

Please Read Carefully:

Information in this document is provided solely in connection with ST products. STMicroelectronics NV and its subsidiaries ("ST") reserve the right to make changes, corrections, modifications or improvements, to this document, and the products and services described herein at any time, without notice.

All ST products are sold pursuant to ST's terms and conditions of sale.

Purchasers are solely responsible for the choice, selection and use of the ST products and services described herein, and ST assumes no liability whatsoever relating to the choice, selection or use of the ST products and services described herein.

No license, express or implied, by estoppel or otherwise, to any intellectual property rights is granted under this document. If any part of this document refers to any third party products or services it shall not be deemed a license grant by ST for the use of such third party products or services, or any intellectual property contained therein or considered as a warranty covering the use in any manner whatsoever of such third party products or services or any intellectual property contained therein.

UNLESS OTHERWISE SET FORTH IN ST'S TERMS AND CONDITIONS OF SALE ST DISCLAIMS ANY EXPRESS OR IMPLIED WARRANTY WITH RESPECT TO THE USE AND/OR SALE OF ST PRODUCTS INCLUDING WITHOUT LIMITATION IMPLIED WARRANTIES OF MERCHANTABILITY, FITNESS FOR A PARTICULAR PURPOSE (AND THEIR EQUIVALENTS UNDER THE LAWS OF ANY JURISDICTION), OR INFRINGEMENT OF ANY PATENT, COPYRIGHT OR OTHER INTELLECTUAL PROPERTY RIGHT.

ST PRODUCTS ARE NOT DESIGNED OR AUTHORIZED FOR USE IN: (A) SAFETY CRITICAL APPLICATIONS SUCH AS LIFE SUPPORTING, ACTIVE IMPLANTED DEVICES OR SYSTEMS WITH PRODUCT FUNCTIONAL SAFETY REQUIREMENTS; (B) AERONAUTIC APPLICATIONS; (C) AUTOMOTIVE APPLICATIONS OR ENVIRONMENTS, AND/OR (D) AEROSPACE APPLICATIONS OR ENVIRONMENTS. WHERE ST PRODUCTS ARE NOT DESIGNED FOR SUCH USE, THE PURCHASER SHALL USE PRODUCTS AT PURCHASER'S SOLE RISK, EVEN IF ST HAS BEEN INFORMED IN WRITING OF SUCH USAGE, UNLESS A PRODUCT IS EXPRESSLY DESIGNATED BY ST AS BEING INTENDED FOR "AUTOMOTIVE, AUTOMOTIVE SAFETY OR MEDICAL" INDUSTRY DOMAINS ACCORDING TO ST PRODUCT DESIGN SPECIFICATIONS. PRODUCTS FORMALLY ESCC, QML OR JAN QUALIFIED ARE DEEMED SUITABLE FOR USE IN AEROSPACE BY THE CORRESPONDING GOVERNMENTAL AGENCY.

Resale of ST products with provisions different from the statements and/or technical features set forth in this document shall immediately void any warranty granted by ST for the ST product or service described herein and shall not create or extend in any manner whatsoever, any liability of ST.

ST and the ST logo are trademarks or registered trademarks of ST in various countries.

Information in this document supersedes and replaces all information previously supplied.

The ST logo is a registered trademark of STMicroelectronics. All other names are the property of their respective owners.

© 2014 STMicroelectronics - All rights reserved

STMicroelectronics group of companies

Australia - Belgium - Brazil - Canada - China - Czech Republic - Finland - France - Germany - Hong Kong - India - Israel - Italy - Japan - Malaysia - Malta - Morocco - Philippines - Singapore - Spain - Sweden - Switzerland - United Kingdom - United States of America

www.st.com

