

## Rad-hard 4.5 A dual inverting low-side MOSFET driver

Datasheet - preliminary data

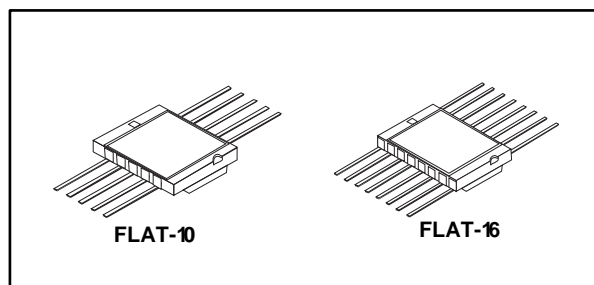

### Applications

- Switch mode power supply
- DC-DC converters
- Motor controllers
- Line drivers

### Description

The RHRPM4423 is a flexible, high-frequency dual low-side driver specifically designed to work with high capacitive MOSFETs and IGBTs in an environment with high levels of radiation such as aerospace. The RHRPM4423 outputs can sink and source 4.5 A of peak current independently. If two PWM outputs are in parallel, a higher driving current (up to 9 A peak) can be achieved. The RHRPM4423 works with CMOS/TTL compatible PWM signal so it can be driven by an external PWM controller, such as the ST1843 or the ST1845. The FLAT-16 version conforms to an industry standard pinout and can dissipate up to 550 mW per channel, while FLAT-10 version optimizes the PCB real estate. Since both of packages are hermetic, this device is suitable for any kind of harsh-environment.

### Features

- Wide operating voltage range: 4.65 V to 18 V
- Parallel driving capability up to 9 A
- Inverting configuration
- Input 5 V logic level compatibility
- 110 ns typical propagation delay
- Matched propagation delays between the two channels (5 ns max.)
- 20 mV maximum low level output voltage
- 30 ns rise and fall times
- +/-5 V common mode bouncing between signal and power grounds
- TID:
  - 100 krad HDR
  - 100 krad LDR
- QML-V qualification planned
- Hermetic package

Table 1: Device summary

Order code	SMD pin	Quality level	EPPL	Package	Max. power dissipation [mW] <sup>(1)</sup>	Mass [g]	Temperature range
RHRPM4423K01V <sup>(2)(3)</sup>	-	QML-V	-	FLAT-16	550	0.7	-55 to 125 °C
RHRPM4423K02V <sup>(2)(3)</sup>							
RH-PM4423K1 <sup>(3)</sup>		Engineering model		FLAT-10	350		
RH-PM4423LK1 <sup>(2)(3)</sup>							

#### Notes:

<sup>(1)</sup> Per channel at T<sub>a</sub> = 70 °C

<sup>(2)</sup> Under development.

<sup>(3)</sup> Contact ST sales office for information about die specific conditions and other quality levels.

## Contents

<b>1</b>	<b>Block diagram</b> .....	<b>3</b>
<b>2</b>	<b>Pin configuration</b> .....	<b>4</b>
<b>3</b>	<b>Typical application diagrams</b> .....	<b>6</b>
<b>4</b>	<b>Maximum ratings</b> .....	<b>7</b>
<b>5</b>	<b>Electrical characteristics</b> .....	<b>8</b>
<b>6</b>	<b>Radiations</b> .....	<b>10</b>
	6.1 Total ionizing dose (MIL-STD-883 test method 1019).....	10
	6.2 Heavy Ions .....	10
<b>7</b>	<b>Device description</b> .....	<b>11</b>
	7.1 Overview .....	11
	7.2 Input stage .....	11
	7.3 Output stage.....	12
	7.4 Parallel output operation .....	12
	7.5 Gate driver voltage flexibility .....	12
<b>8</b>	<b>Design guidelines</b> .....	<b>13</b>
	8.1 Output series resistance .....	13
	8.2 Power dissipation .....	13
<b>9</b>	<b>Layout and application guidelines</b> .....	<b>17</b>
<b>10</b>	<b>Typical performance characteristics</b> .....	<b>19</b>
<b>11</b>	<b>Package information</b> .....	<b>22</b>
	11.1 FLAT-16 package information .....	22
	11.2 FLAT-10 package information .....	23
<b>12</b>	<b>Ordering information</b> .....	<b>25</b>
<b>13</b>	<b>Other information</b> .....	<b>26</b>
	13.1 Data code.....	26
	13.2 Documentation .....	26
<b>14</b>	<b>Revision history</b> .....	<b>27</b>

# 1 Block diagram

Figure 1: Block diagram

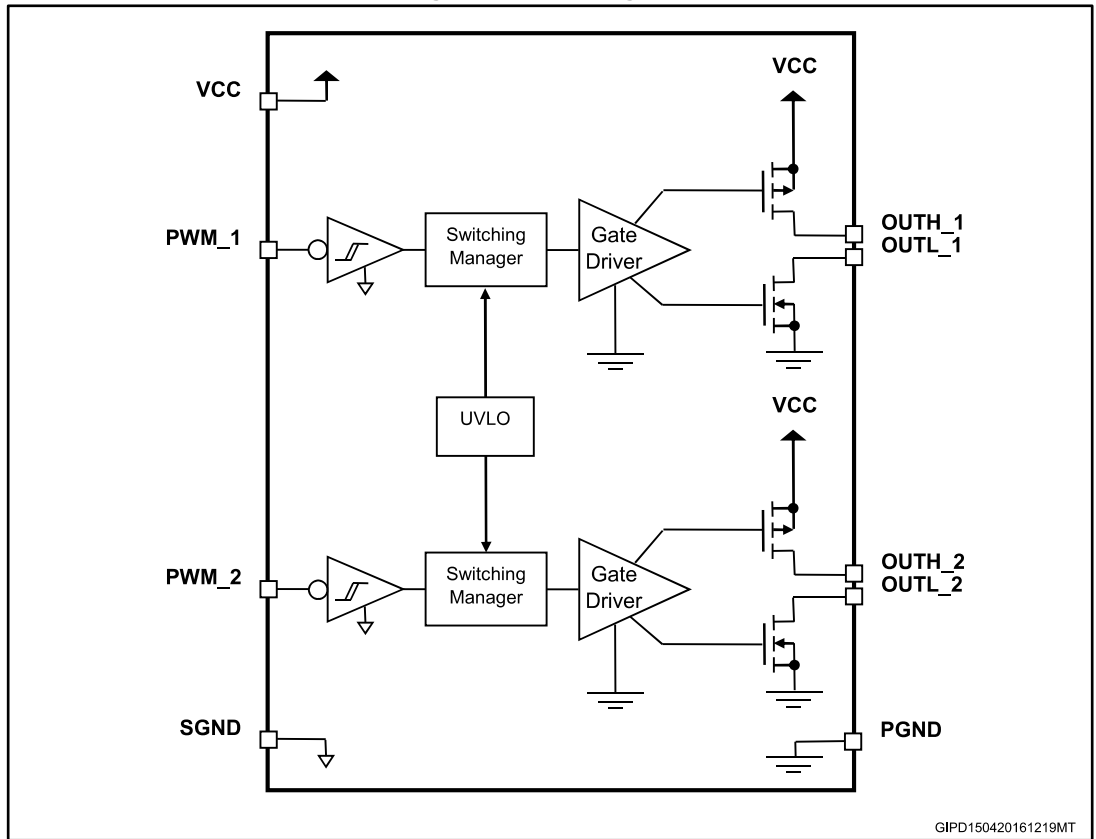

GIPD150420161219MT

## 2 Pin configuration

Figure 2: Pin configuration (top view)

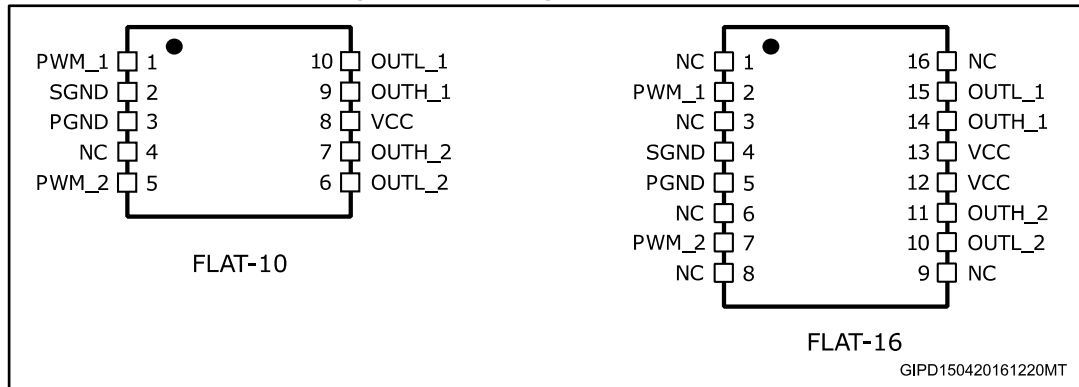

FLAT-10: the upper metallic package lid is connected to pin 4.

FLAT-16: the upper metallic package lid and the metallized bottom surface are electrically floating.

Table 2: Pin description

Pin name		Name	Type	Description
FLAT-10	FLAT-16			
8	12 13	VCC	Supply	Supply voltage. Low ESR bypass (for example MLCC type) capacitor to the PCB ground plane.
3	5	PGND	Ground	Ground reference for output drivers. Connect this pin to the PCB ground plane.
2	4	SGND	Ground	Ground reference for PWM input pins. Input pin (PWM_1, PWM_2 and SGND) common mode can range +/-5 V versus PGND. Ground reference for PWM input pins. Input pin (PWM_1, PWM_2 and SGND) common mode can range +/-5 V versus PGND.
1	2	PWM_1	I	PWM input signal (inverting) for driver 1 featuring TTL/CMOS compatible threshold and hysteresis. Do not leave the pin floating.
5	7	PWM_2	I	PWM input signal (inverting) for driver 2 featuring TTL/CMOS compatible threshold and hysteresis. Do not leave the pin floating.
9	14	OUTH_1	O	High-side open drain pin of driver 1. Connect this pin to OUTL_1 either directly or by an external resistor if an asymmetric ON/OFF switching time is required.
10	15	OUTL_1	O	Low-side open drain pin of driver 1. Connect this pin to OUTH_1 either directly or by an external resistor if an asymmetric ON/OFF switching time is required.
7	11	OUTH_2	O	High-side open drain pin of driver 2. Connect this pin to OUTL_2 either directly or by an external resistor if an asymmetric ON/OFF switching time is required.

Pin name		Name	Type	Description
FLAT-10	FLAT-16			
6	10	OUTL_2	O	Low-side open drain pin of driver 2. Connect this pin to OUTH_2 either directly or by an external resistor if an asymmetric ON/OFF switching time is required.
4	1 3 6 9 16	NC		Not connected pin. Leave it floating or connect it to any potential.

### 3 Typical application diagrams

Figure 3: Typical application diagram

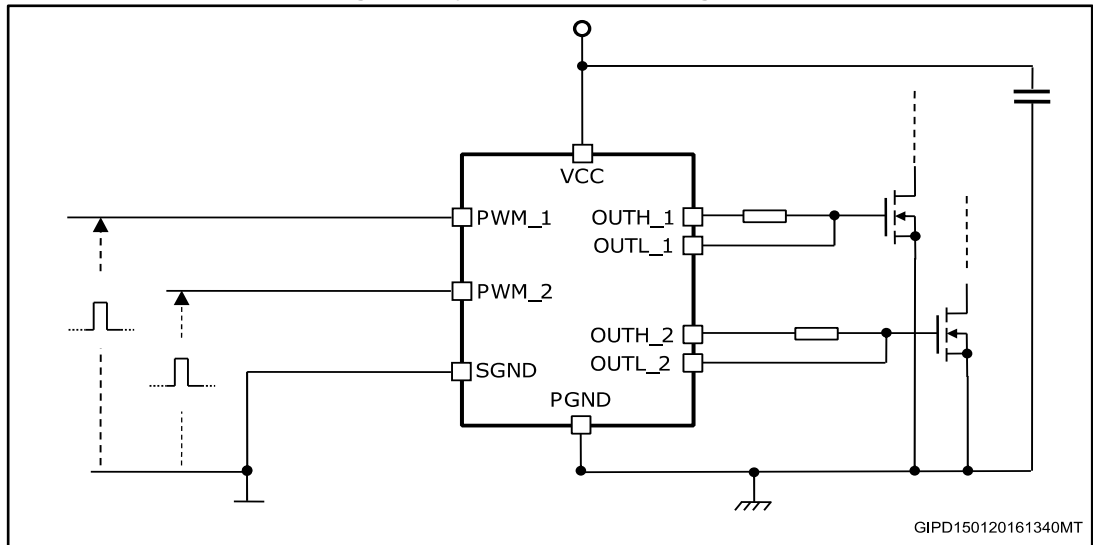

SGND and PGND can be shorted or decoupled up to +/-5 V.

Figure 4: Typical application diagram as buck switching regulator

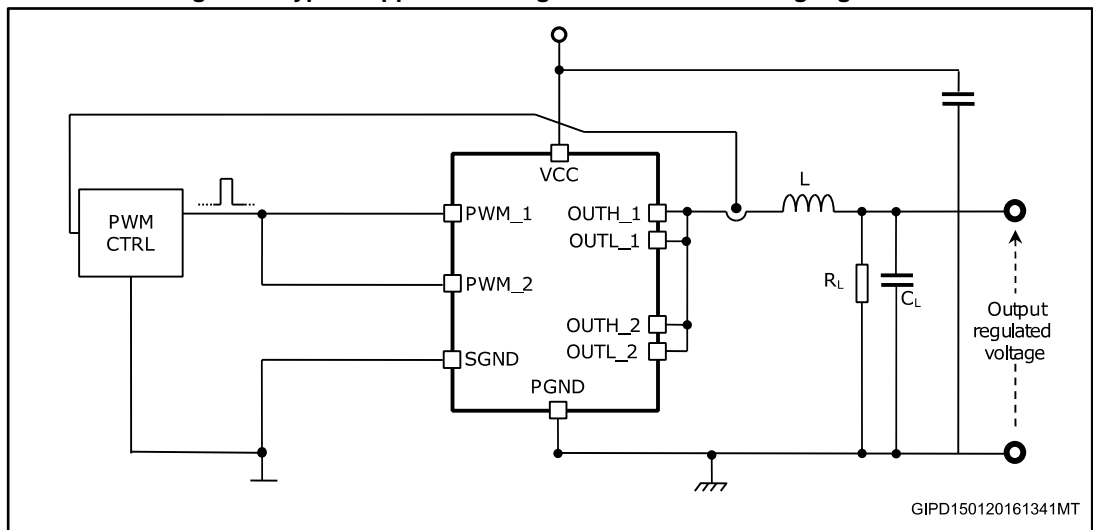

SGND and PGND can be shorted or decoupled up to +/-5 V.

In [Figure 4: "Typical application diagram as buck switching regulator"](#), the output stage of the RHRPM4423 device directly drives an inductor; in this configuration, the RHRPM4423 output stages are in parallel to exploit the maximum current capability of the device. The MOSFET driver works as a synchronous buck converter.

## 4 Maximum ratings

Table 3: Thermal data

Symbol	Parameter	Value		Unit
		FLAT-10	FLAT-16	
$R_{thjc}$	Max. thermal resistance, junction-to-case	25	8	°C/W
$R_{thja}^{(1)}$	Max. thermal resistance, junction-to-ambient	117	70	°C/W
$P_{TOT}$	Maximum power dissipation @ $T_{amb} = 70\text{ °C}$	0.70	1.10	W
$P_{TOT}$	Maximum power dissipation @ $T_{amb} = 125\text{ °C}$	0.21	0.36	W

**Notes:**

(1) Measured on 2s2p board as per standard JEDEC (JESD51-7) in natural convection.

Table 4: Absolute maximum ratings

Symbol	Parameter	Value	Unit
$V_{CC}$	Supply voltage	PGND-0.3 to PGND+20	V
PGND	Power ground	-	V
SGND	Signal ground	PGND-5 to PGND+5	V
PWM_1			
PWM_2	PWM input	SGND-0.3 to VCC+0.3	V
OUT_1			
OUT_2	Driver output	PGND-0.3 to VCC+0.3	V
$I_{OUT}$	DC output current (for each driver)	750	mA
$T_{stg}$	Storage temperature	-65 to 150	°C
$T_J$	Maximum operating junction temperature	150	°C
$T_{LEAD}$	Lead temperature (soldering, 10 seconds) <sup>(1)</sup>	300	°C
$V_{HBM}$	ESD capability, human body model	2000	V
$V_{MM}$	ESD capability, machine model	200	V

**Notes:**

(1) The distance is 1.5 mm far from the device body and the same lead is resoldered after 3 minutes.

## 5 Electrical characteristics

$V_{CC} = 4.65\text{ V to }18\text{ V}$  and  $T_J = -55\text{ to }125\text{ }^\circ\text{C}$ , unless otherwise specified.

**Table 5: Electrical characteristics**

Symbol	Parameter	Test conditions	Min.	Typ.	Max.	Unit
$I_{CC}$	$V_{CC}$ quiescent current	$V_{CC} = 18\text{ V}$ Inputs not switching OUTH_1 $\equiv$ OUTL_1 OUTH_2 $\equiv$ OUTL_2 $T_J = 25\text{ }^\circ\text{C}$		1.6	2.1	mA
$V_{UVLO}$	Undervoltage lockout threshold for turn-on	$V_{CC}$ rising		4.3	4.65	V
	Undervoltage lockout hysteresis			300		mV
<b>Input stage</b>						
PWM_x	Input at high level – $V_{IH}$	Rising threshold	2.0			V
	Input at low level – $V_{IL}$	Falling threshold			0.8	V
$I_{PWM}$	PWM_x input pin current	PWM_x = SGND	-1		+1	$\mu\text{A}$
		PWM_x = 3.3 V $V_{CC} = 10\text{ V}$ and $18\text{ V}$	0		+2	
		PWM_x = $V_{CC}-0.5\text{ V}$ $V_{CC} = 18\text{ V}$	0		+5	
dVPWM/dt	PWM_x input pin transient <sup>(1)</sup>		100			mV/s
<b>Output stage</b>						
$R_{hi}$	Source resistance	$V_{CC} = 10\text{ V}$ Inputs at low level $I_{OUT} = 100\text{ mA}$ $T_J = 25\text{ }^\circ\text{C}$		0.7	1.1	$\Omega$
		$V_{CC} = 10\text{ V}$ Inputs at low level $I_{OUT} = 100\text{ mA}$			1.4	$\Omega$
$R_{lo}$	Sink resistance	$V_{CC} = 10\text{ V}$ Inputs at high level $I_{OUT} = 100\text{ mA}$ $T_J = 25\text{ }^\circ\text{C}$		1.0	1.4	$\Omega$
		$V_{CC} = 10\text{ V}$ Inputs at high level $I_{OUT} = 100\text{ mA}$			1.9	$\Omega$
$I_{SOURCE}$	Source peak current <sup>(1)</sup>	$V_{CC} = 10\text{ V}$ Inputs at low level $C_{OUT}$ to GND = $10\text{ nF}$		5.5		A

Symbol	Parameter	Test conditions	Min.	Typ.	Max.	Unit
I <sub>SINK</sub>	Sink peak current <sup>(1)</sup>	VCC = 10 V Inputs at high level C <sub>OUT</sub> to GND = 10 nF		4.5		A
V <sub>OH</sub>	High level output voltage, VCC-V <sub>OUT</sub>	Inputs at low level OUTH_1 ≡ OUTL_1 OUTH_2 ≡ OUTL_2 I <sub>OUT</sub> = 1 mA			10	mV
V <sub>OL</sub>	Low level output voltage, V <sub>OUT</sub>	Inputs at high level OUTH_1 ≡ OUTL_1 OUTH_2 ≡ OUTL_2 I <sub>OUT</sub> = 1 mA			10	mV
t <sub>R</sub>	Output rise time	VCC = 10 V OUTH_1 ≡ OUTL_1 OUTH_2 ≡ OUTL_2 C <sub>OUT</sub> to GND = 10 nF		30		ns
t <sub>F</sub>	Output fall time	VCC = 10 V OUTH_1 ≡ OUTL_1 OUTH_2 ≡ OUTL_2 C <sub>OUT</sub> to GND = 10 nF		30		ns
<b>Propagation delay</b>						
t <sub>D</sub>	Input- to-output delay time	VCC = 10 V OUTH_1 ≡ OUTL_1 OUTH_2 ≡ OUTL_2 C <sub>OUT</sub> to GND = 10 nF		110		ns
	Matching between propagation delays <sup>(1)</sup>		-5		5	ns

**Notes:**

<sup>(1)</sup> Parameter guaranteed at design level, not tested in production.

## 6 Radiations

### 6.1 Total ionizing dose (MIL-STD-883 test method 1019)

The products that are guaranteed in radiation within RHA QML-V system, fully comply with the MIL-STD-883 test method 1019 specification. The RHRPM4423 is being RHA QML-V qualified, tested and characterized in full compliance with the MIL-STD-883 specification, both below 10 mrad/s (low dose rate) and between 50 and 300 rad/s (high dose rate).

- Testing is performed in accordance with MIL-PRF-38535 and the test method 1019 of the MIL-STD-883 for total ionizing dose (TID).
- ELDRS characterization is performed in qualification only on both biased and unbiased parts, on a sample of ten units from two different wafer lots.
- Each wafer lot is tested at high dose rate only, in the worst bias case condition, based on the results obtained during the initial qualification.

**Table 6: TID**

Type	Conditions	Value	Unit
TID	50 rad(Si)/s high dose rate up to	100	krad
	10 mrad(Si)/s low dose rate up to	100	
	ELDRS free up to	100	
Output stage source resistance drift	From 0 krad to 100 krad at 50 rad/s	< 0.3	$\Omega$
Output stage sink resistance drift	From 0 krad to 100 krad at 50 rad/s	< 0.3	$\Omega$

### 6.2 Heavy Ions

The heavy ions trials are performed on qualification lots only. No additional test is performed. The table below summarizes the results of heavy ion tests.

**Table 7: HI**

Feature	Conditions	Value	Unit
SEL/SEB	LET = 60 MeV.cm <sup>2</sup> /mg V <sub>CC</sub> = 18 V	No latch-up/burnout	-
	LET = 70 MeV.cm <sup>2</sup> /mg V <sub>CC</sub> = 16 V	No latch-up/burnout	
SET	V <sub>CC</sub> = 4.5 V	LET <sub>TH</sub> = 0	MeV*cm <sup>2</sup> /mg
		$\sigma_{SAT} = 7*10^{-6}$	cm <sup>2</sup>
	V <sub>CC</sub> = 18 V	LET <sub>TH</sub> = 18	MeV*cm <sup>2</sup> /mg
		$\sigma_{SAT} = 2*10^{-6}$	cm <sup>2</sup>

## 7 Device description

### 7.1 Overview

The RHRPM4423 is a dual inverting low-side driver, which charges and discharges big capacitive loads like MOSFETs or IGBTs used in power supplies and DC-DC modules. The RHRPM4423 can sink and source 4.5 A on each low-side driver branch but a higher driving current can be obtained by paralleling its outputs. Even though this device has been designed to cope with loads requiring high peak current and fast switching time, the ultimate driving capability depends on the power dissipation in the device, which must be kept below the power dissipation capability of the package, see [Section 8.2: "Power dissipation"](#). The RHRPM4423 uses VCC pin to supply and two ground pins (SGND signal ground and PGND power ground) for return. SGND is used as reference ground for the input stage and it can be connected to ground of the remote controller. PGND is the reference ground for the output stage; SGND can bounce +/-5 V versus PGND so that PWM input pin common mode can range +/-5 V versus PGND. The dual low-side driver has been designed to work with supply voltage in the range from 4.65 V to 18 V. Before VCC overcomes UVLO threshold (VUVLO), the RHRPM4423 keeps off both low-side MOSFETs (OUTL\_x outputs are grounded) then, after UVLO threshold has crossed, PWM input keeps the control of the driver operations. Input pins (PWM\_1 and PWM\_2), which are CMOS/TTL compatible, can work with voltages up to VCC.

### 7.2 Input stage

PWM inputs of the RHRPM4423 dual inverting low-side driver are compatible to CMOS/TTL levels with capability to be pulled up to VCC. The relation between PWM\_1 and PWM\_2 input pins and the corresponding PWM output are depicted in [Figure 5: "Time diagram"](#). In the worst case, input levels above 2.0 V are recognized as high logic values and values below 0.8 V are recognized as low logic values. Input-to-output propagation delays ( $t_D$ ), rise ( $t_R$ ) and fall ( $t_F$ ) times have been designed to assure the operation in fast switching environment. The matching between delays in the two branches of the RHRPM4423 assures symmetry in the operations and allows the parallel output functionality. SGND input stage ground reference can bounce versus PGND +/-5 V.

Figure 5: Time diagram

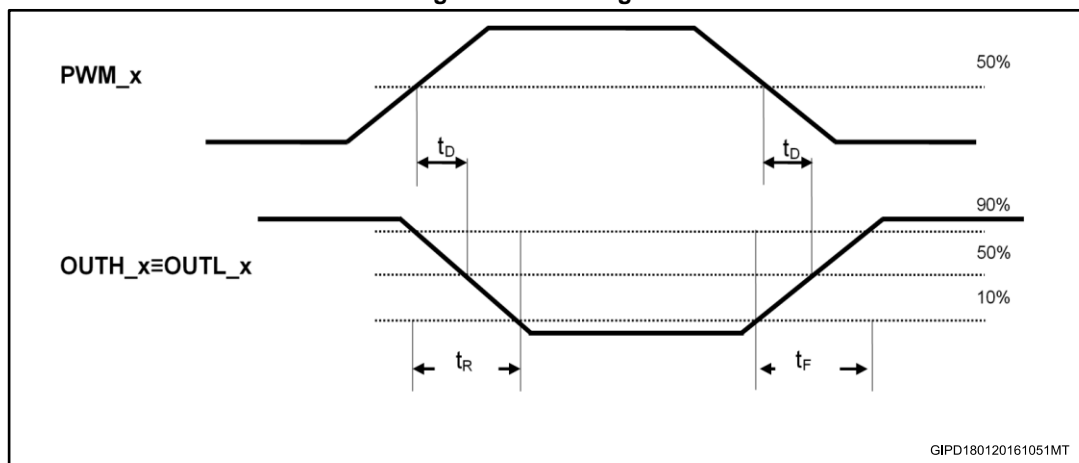

### 7.3 Output stage

The RHRPM4423 output stage uses ST’s proprietary lateral DMOS. Both NDMOS and PDMOS have been sized to exhibit high driving peak current as well as low on-resistance. When OUTL\_x and OUTH\_x are connected together, the typical peak current is 4.5 A. The device features the adaptive anti-cross-conduction protection. The RHRPM4423 continuously monitors the status of the internal NDMOS and PDMOS: in case of a PWM transition, before the desired DMOS switches on, the device awaits until the other DMOS completely turns off. No static current flows from VCC to ground.

### 7.4 Parallel output operation

For applications demanding high driving current capability (over 4.5 A provided by the single branch), the RHRPM4423 allows the two drivers to be in parallel to reach the highest current, up to 9 A. This configuration is depicted in [Figure 6: "Parallel output connection"](#) where PWM\_1 and PWM\_2 and OUTH\_x and OUTL\_x are tied together. The matching of internal propagation delays guarantees that the two drivers switch on and off simultaneously.

Figure 6: Parallel output connection

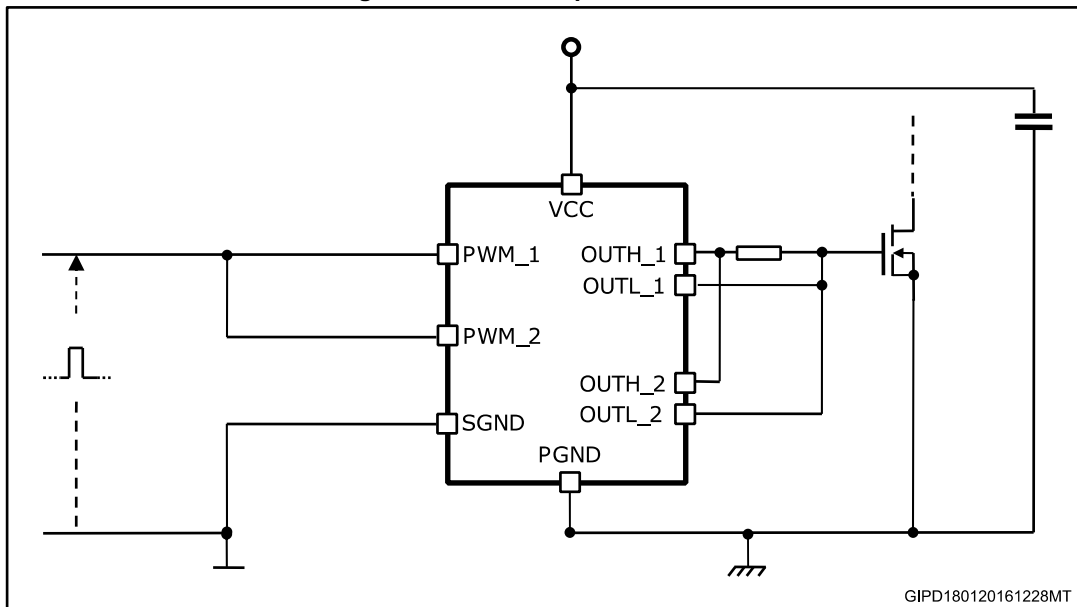

GIPD180120161228MT

### 7.5 Gate driver voltage flexibility

The RHRPM4423 allows the user to select the gate drive voltage so to optimize the efficiency of the application. The low-side MOSFET driving voltage depends on the voltage applied to VCC and can range from 4.65 V to 18 V.

## 8 Design guidelines

### 8.1 Output series resistance

The output resistance allows the high frequency operation without exceeding the maximum power dissipation of the driver package. See [Section 8.2: "Power dissipation"](#) to understand how the output resistance value is obtained. For applications with VCC supply voltage greater than 10 V and high capacitive loads ( $C_g > 10$  nF), the dissipated power in the output stage of the device has to be limited, therefore at least  $2.2 \Omega$  Rg gate resistor has to be added. [Figure 7: "Minimum gate resistance"](#) is a synthetic view of the boundaries for the safe operation of the RHRPM4423.

Figure 7: Minimum gate resistance

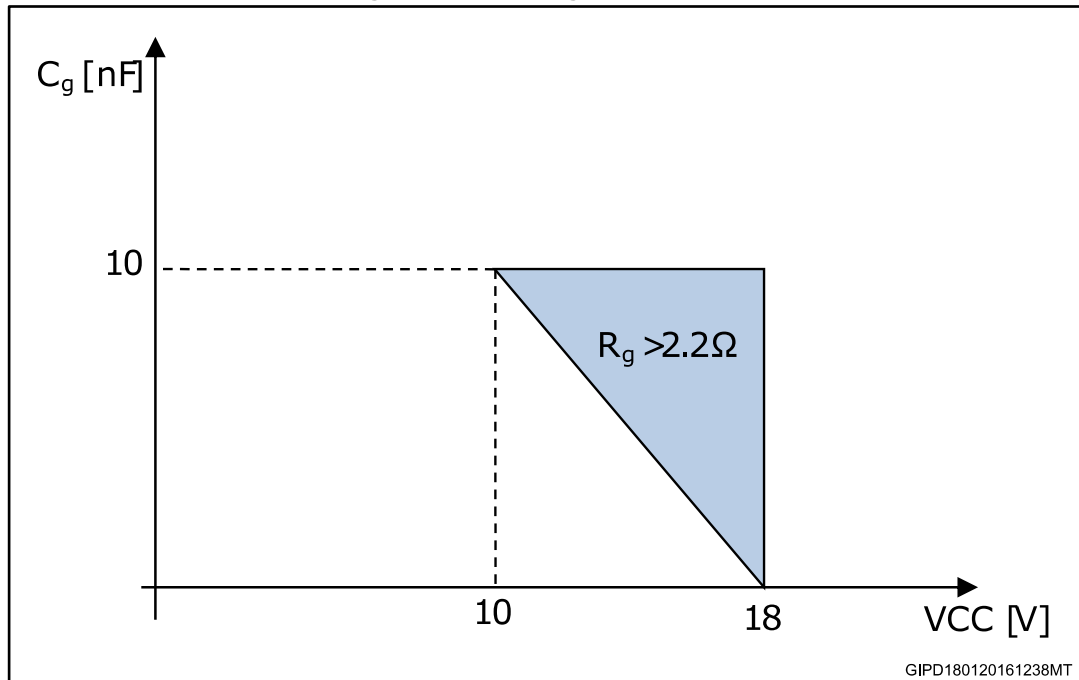

### 8.2 Power dissipation

The RHRPM4423 embeds two high current low-side drivers which drive high capacitive MOSFETs. This section estimates the power dissipated inside the device in normal applications. Two main terms contribute to the device power dissipation: bias power and driver power.

- PDC bias power depends on the static consumption of the device through the supply pins and it is given by below equation:

**Equation 1**

$$P_{DC} = V_{CC} * I_{CC}$$

- The driver power is the necessary power to continuously switch on and off the external MOSFETs; it is a function both of the switching frequency and total gate charge of the selected MOSFETs.  $P_{SW}$  total dissipated power is given by three main factors:
  - external gate resistance (when present)
  - intrinsic MOSFET resistance
  - intrinsic driver resistance

It is indicated in the below equation:

### Equation 2

$$P_{SW} = F_{SW} \cdot (Q_G \cdot V_{CC})$$

When an application is designed using the RHRPM4423, the effect of external gate resistors on the power dissipated by the driver has to be taken into account. External gate resistors help the device to dissipate the switching power since the same power,  $P_{SW}$ , is shared between the internal driver impedance and the external resistor.

In [Figure 7: "Minimum gate resistance"](#), the MOSFET driver can be represented by a push-pull output stage with two different MOSFETs:

- PDMOS to drive the external gate to high level
- NDMOS to drive the external gate to low level (with  $R_{DS(on)}$ :  $R_{hi}$ ,  $R_{lo}$ )

The external MOSFET can be represented as  $C_{gate}$  capacitance, which stores  $Q_G$  gate charge required by the external MOSFET to reach  $V_{CC}$  driving voltage. This capacitance is charged and discharged at  $F_{SW}$  frequency.

$P_{SW}$  total power is dissipated among the resistive components distributed along the driving path. According to the external gate resistance and the intrinsic MOSFET gate resistance, the driver only dissipates a  $P_{SW}$  portion as follows (per driver):

### Equation 3

$$P_{SW} = \frac{1}{2} \cdot C_{gate} \cdot (V_{CC})^2 \cdot F_{SW} \cdot \left( \frac{R_{hi}}{R_{hi} + R_g + R_{load}} + \frac{R_{lo}}{R_{lo} + R_g + R_{load}} \right)$$

The total dissipated power from the driver is given by  $P_{TOT} = P_{DC} + 2 \cdot P_{SW}$ .

Figure 8: Driver and load equivalent circuits

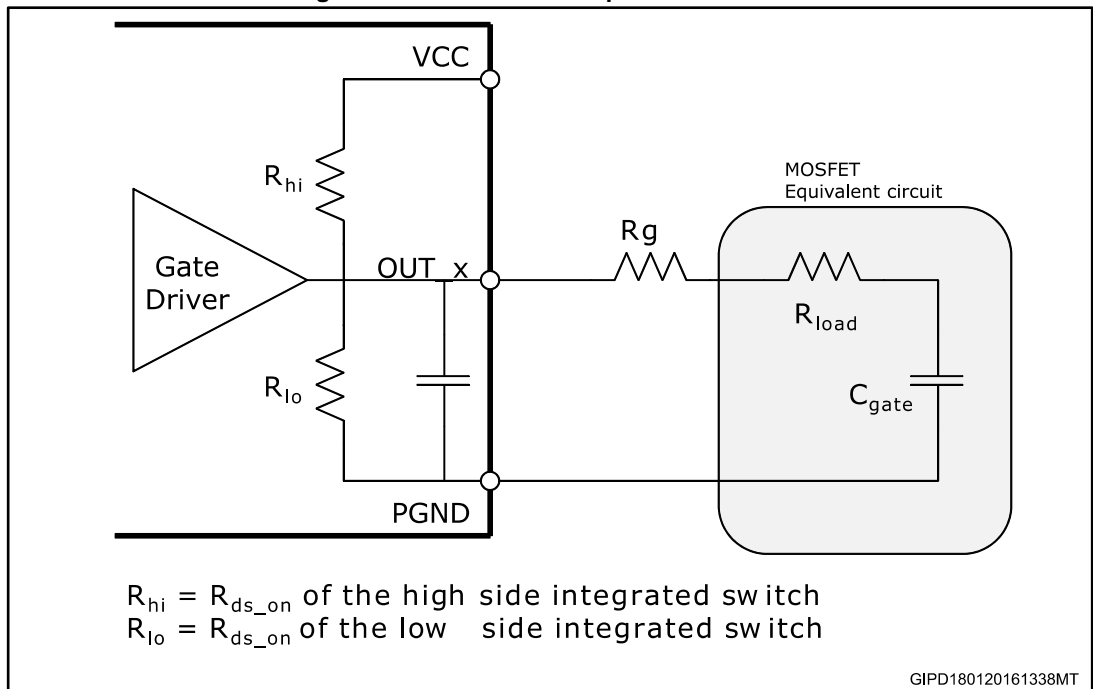

Figure 9: Power dissipation with  $R_g = 2.2 \Omega$

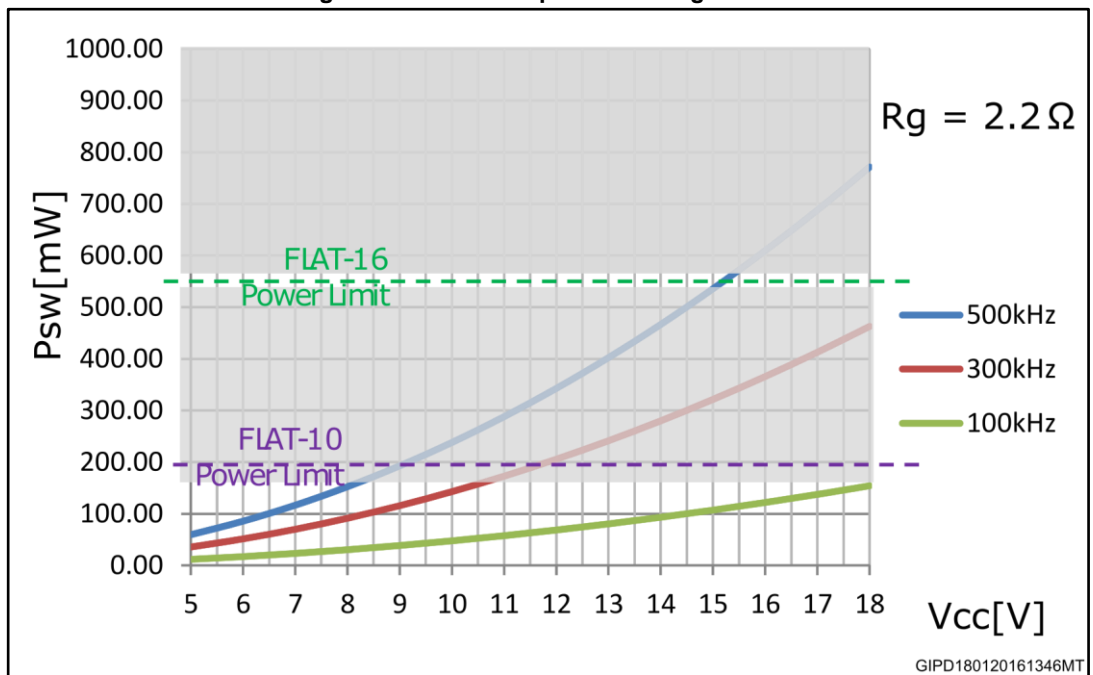
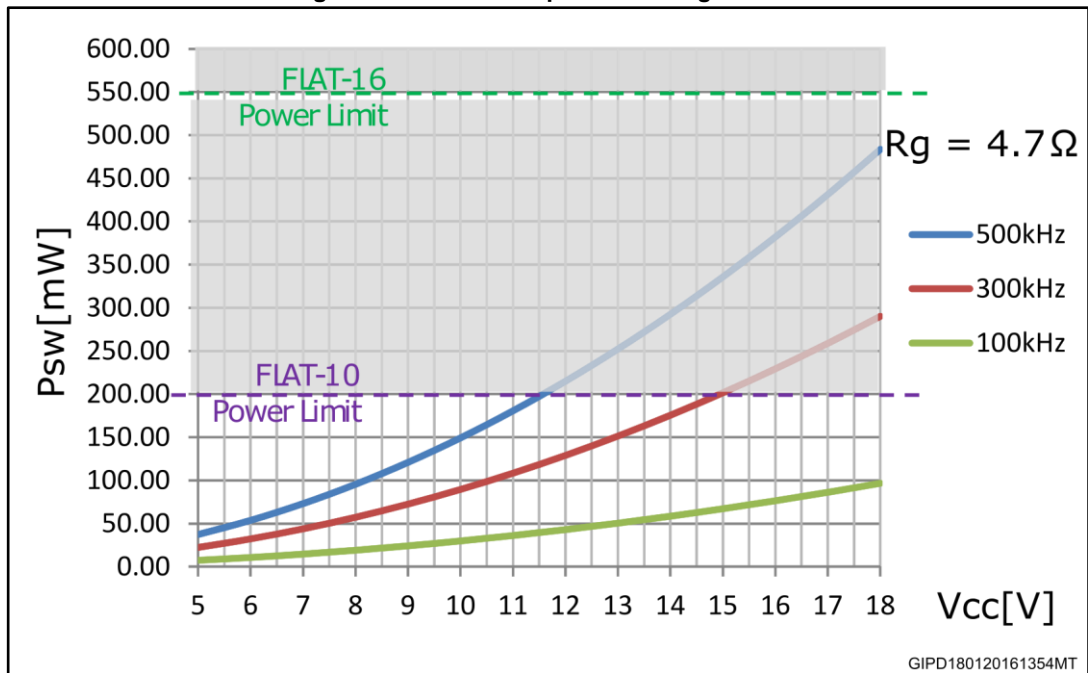
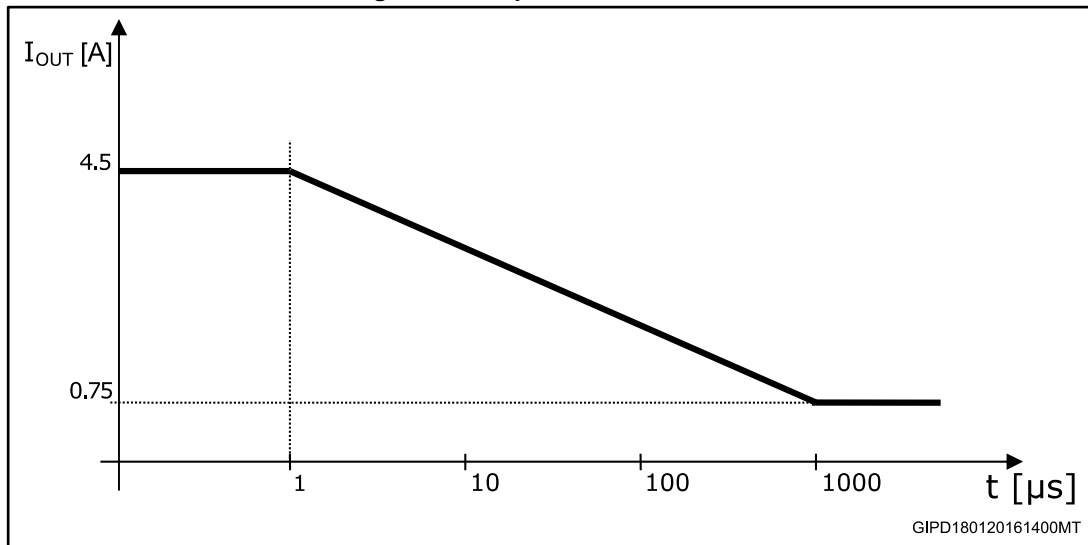

Figure 10: Power dissipation with  $R_g = 4.7 \Omega$



With regard to the power dissipation and current capability purpose, a profile, for the curve output current versus time, is recommended. See the one depicted in [Figure 11: "Output current vs. time"](#):

Figure 11: Output current vs. time



## 9 Layout and application guidelines

The first priority, when components are placed for these applications, is the power section, minimizing the length of each connection and loop. To minimize noise and voltage spikes (EMI and losses as well) power connections have to be a part of a power plane with wide and thick conductor traces: loop has to be minimized. The capacitor on VCC, as well as the output inductor should be placed as closer as possible to IC. Traces between the driver and the external MOSFETs should be short to reduce the inductance of the trace and the ringing in the driving signals. Moreover, the number of vias has to be minimized to reduce the related parasitic effect.

Small signal components and connections to critical nodes of the application as well as bypass capacitors for the device supply are also important. The bypass capacitor (VCC capacitors) has to be placed close to the device with the shortest loop to minimize the parasitic inductance.

To improve heat dissipation, the copper area has to be placed under the IC. This copper area may be connected to other layers (if available) through vias so to improve the thermal conductivity: the combination of copper pad, copper plane and vias under the driver allows the device to reach its best thermal performance. It is important for the power device to have a thermal path compatible with the dissipated power: both the driver and the external MOSFET have to be mounted on a dedicated heat sink (for example, the driver should be soldered on the copper area of the PCB, which is in strict thermal contact to an aluminum frame) sticking each part to the frame (without using any screw for the MOSFET). The glue could be the resin ME7158 (space approved resin). Moreover, two small FR4 spacers could be added to guarantee the electrical isolation of the package from the frame.

A recommended PCB layout is shown in [Figure 12: "Evaluation board layout: top view"](#).

Figure 12: Evaluation board layout: top view

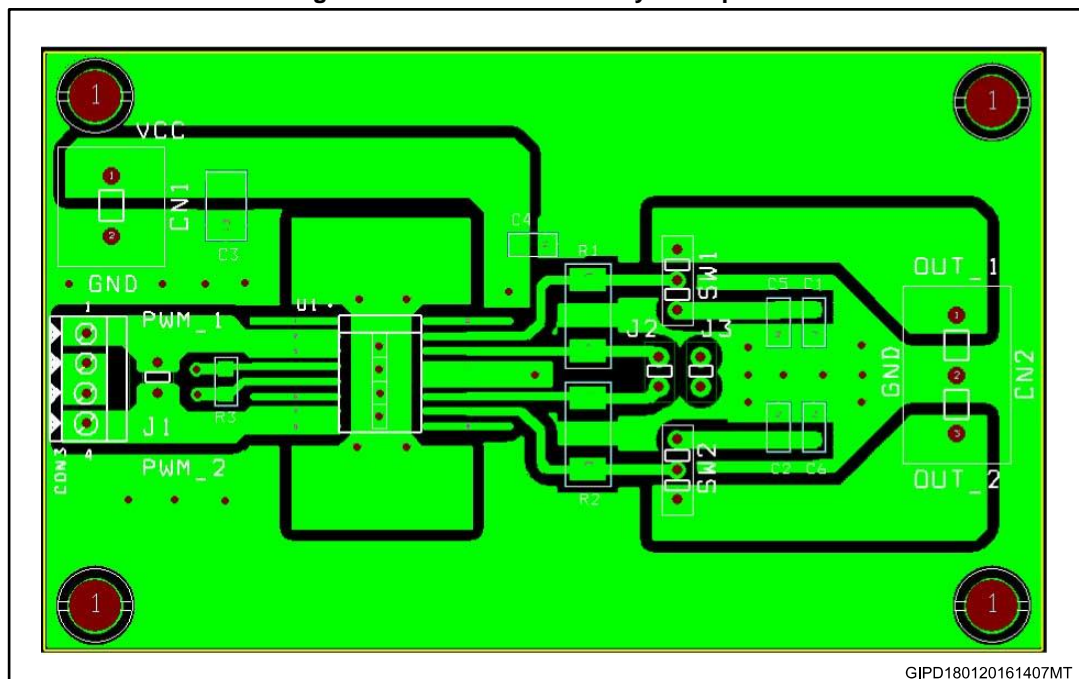
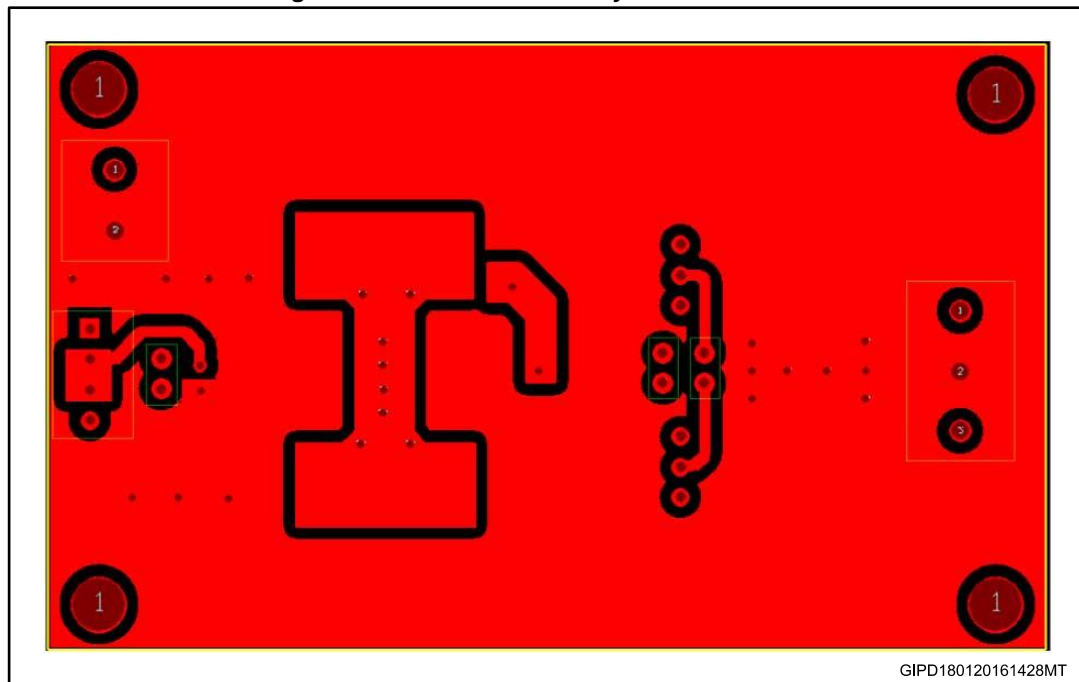
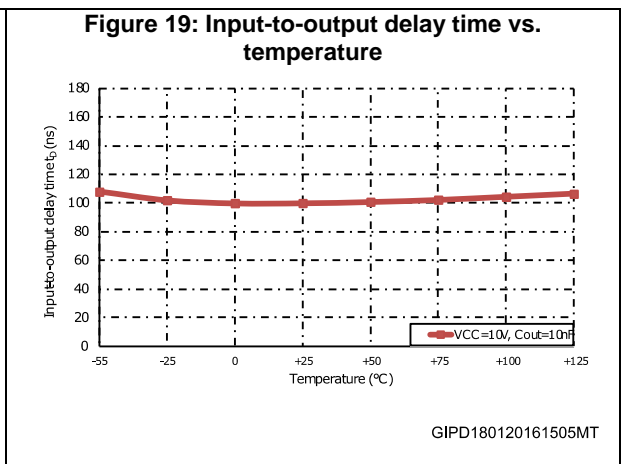
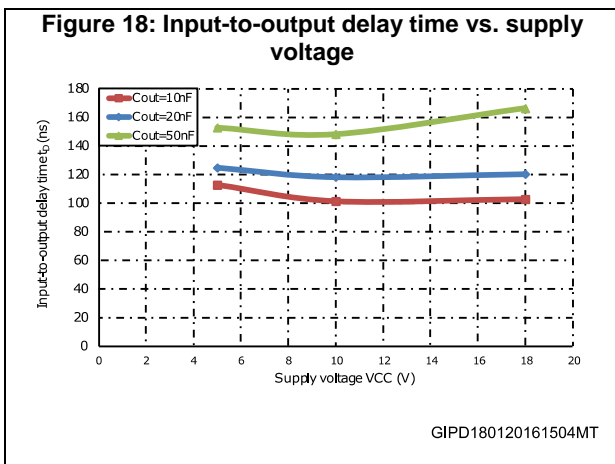
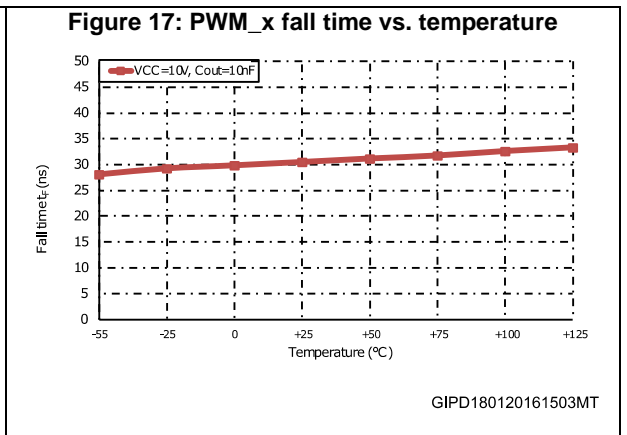
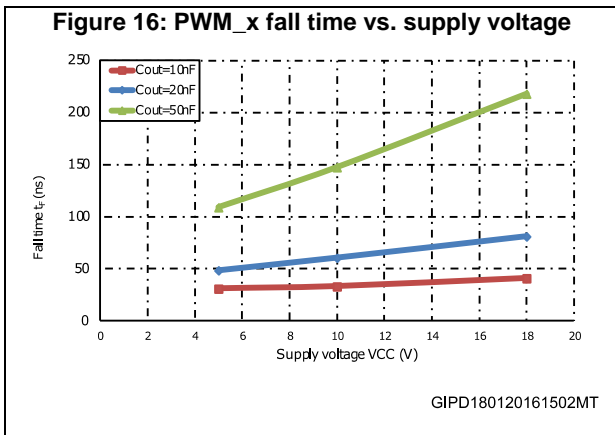
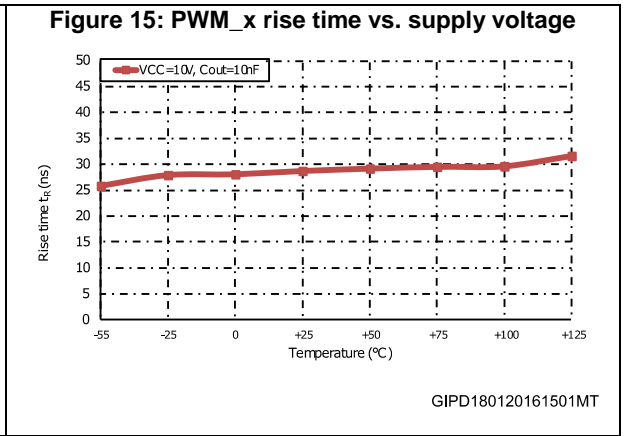
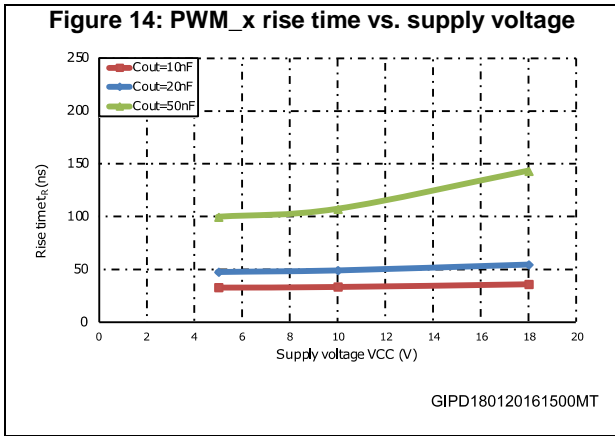

Figure 13: Evaluation board layout: bottom view



# 10 Typical performance characteristics



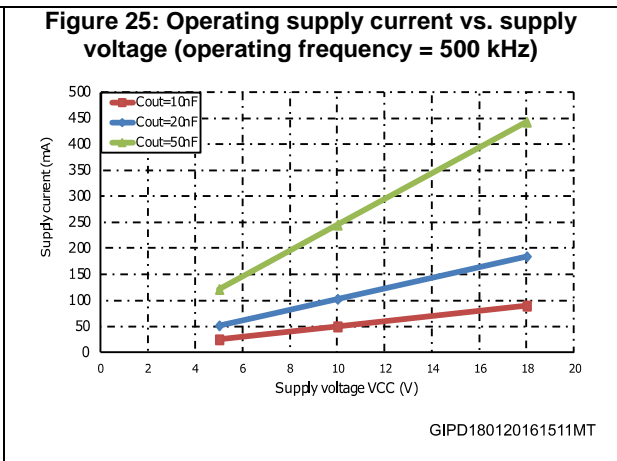
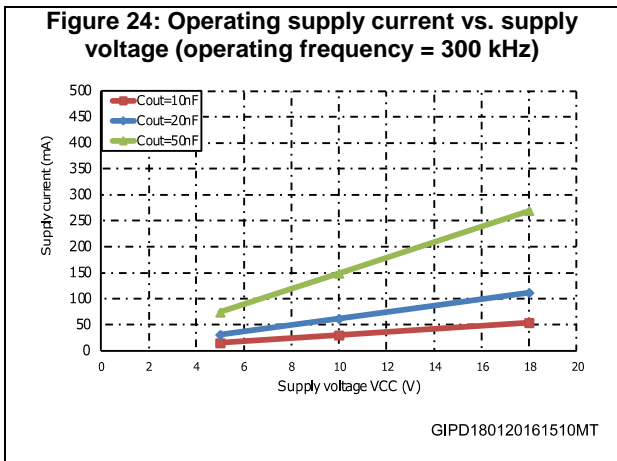
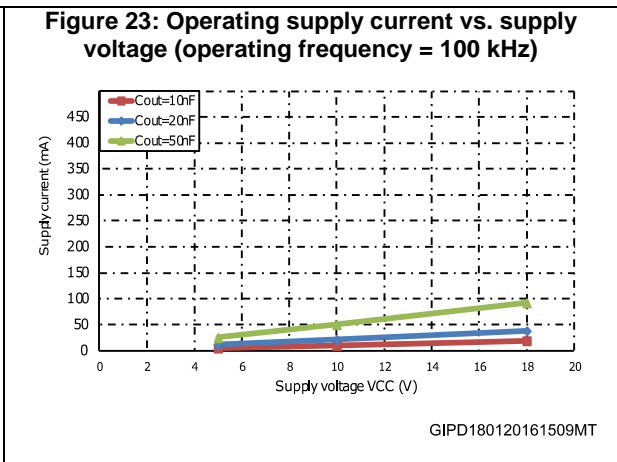
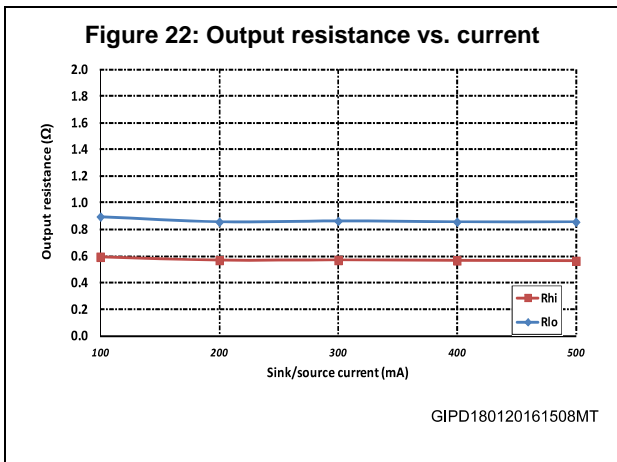
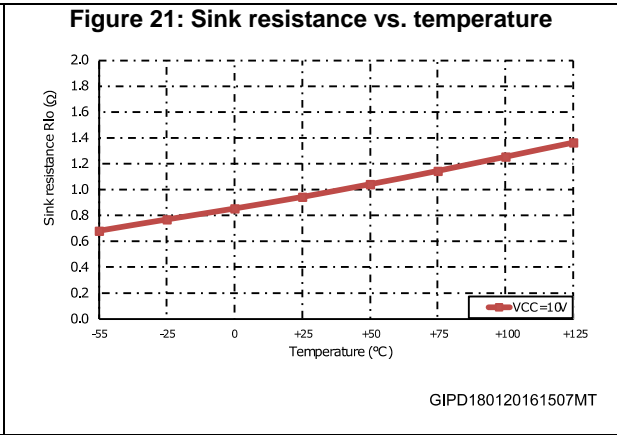
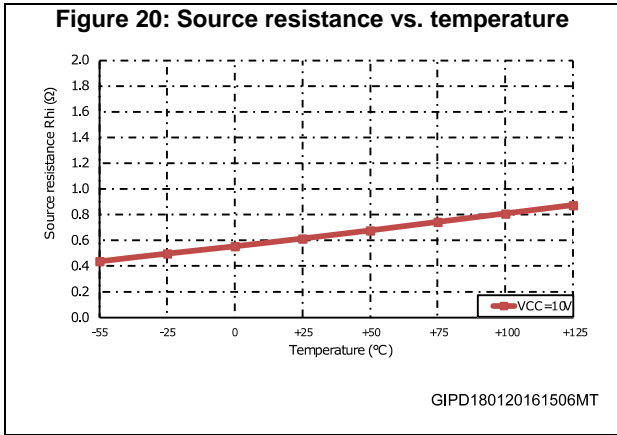
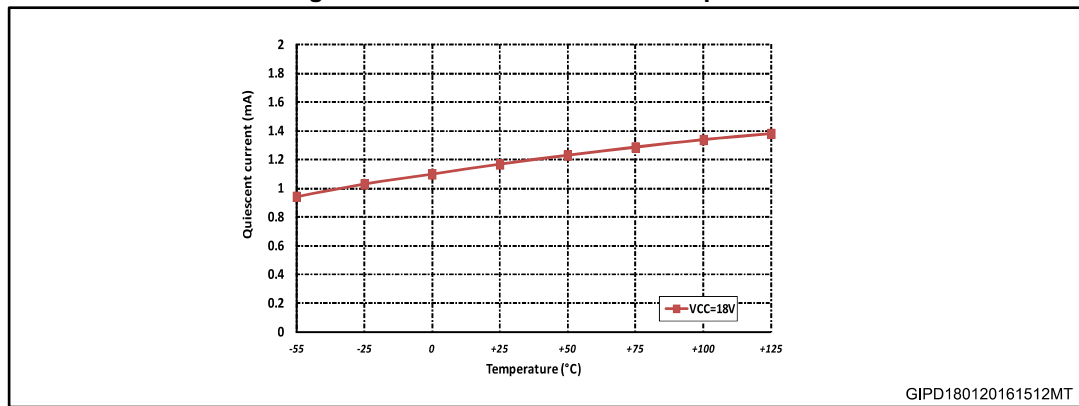

Figure 26: Quiescent current vs. temperature



# 11 Package information

In order to meet environmental requirements, ST offers these devices in different grades of ECOPACK® packages, depending on their level of environmental compliance. ECOPACK® specifications, grade definitions and product status are available at: [www.st.com](http://www.st.com). ECOPACK® is an ST trademark.

## 11.1 FLAT-16 package information

Figure 27: FLAT-16 package outline

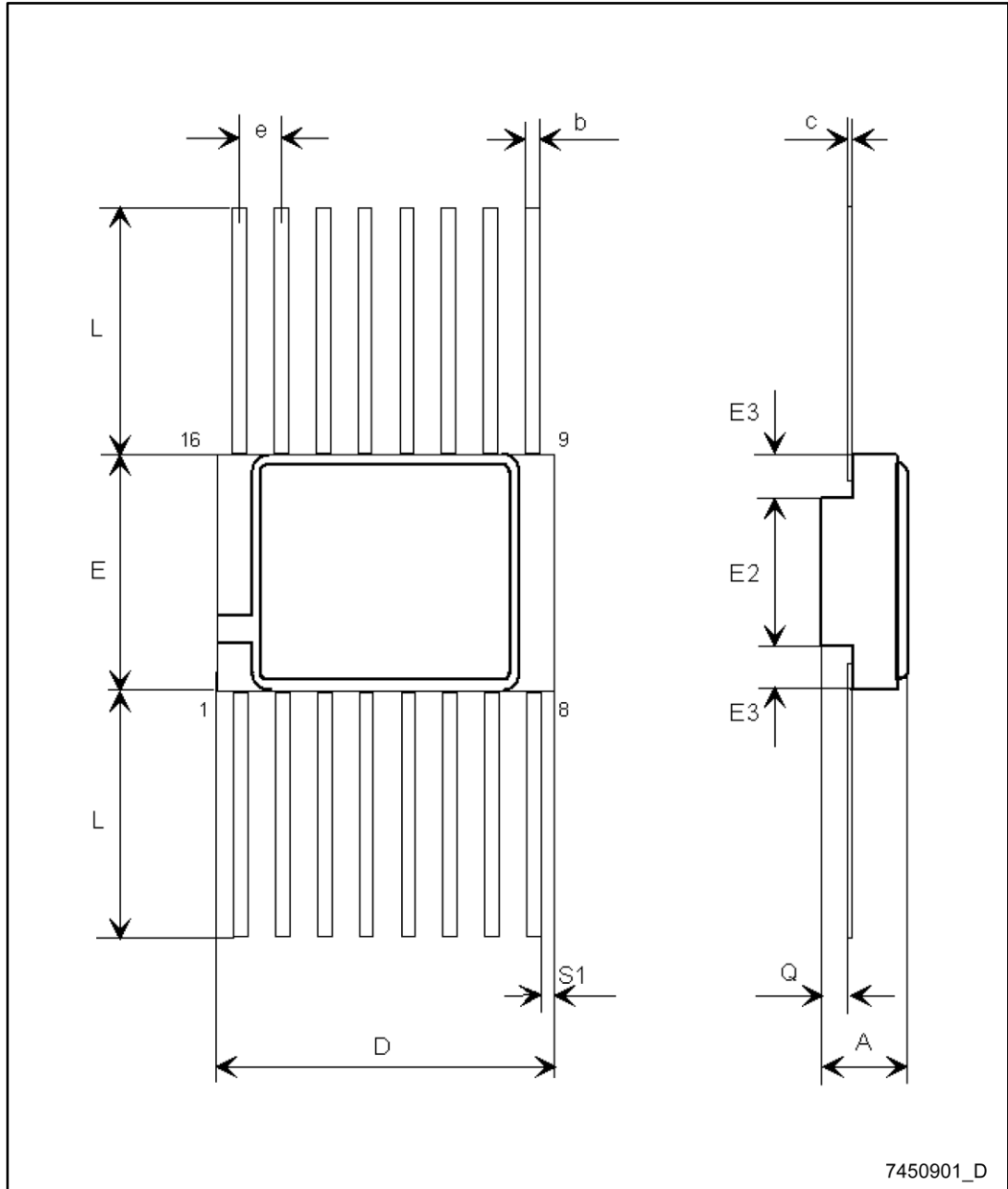

7450901\_D

Table 8: FLAT-16 package mechanical data

Dim.	mm		
	Min.	Typ.	Max.
A	2.42		2.88
b	0.38		0.48
c	0.10		0.18
D	9.71		10.11
E	6.71		7.11
E2	3.30	3.45	3.60
E3	0.76		
e		1.27	
L	6.35		7.36
Q	0.66		1.14
S1	0.13		

## 11.2 FLAT-10 package information

Figure 28: Flat-10 package outline

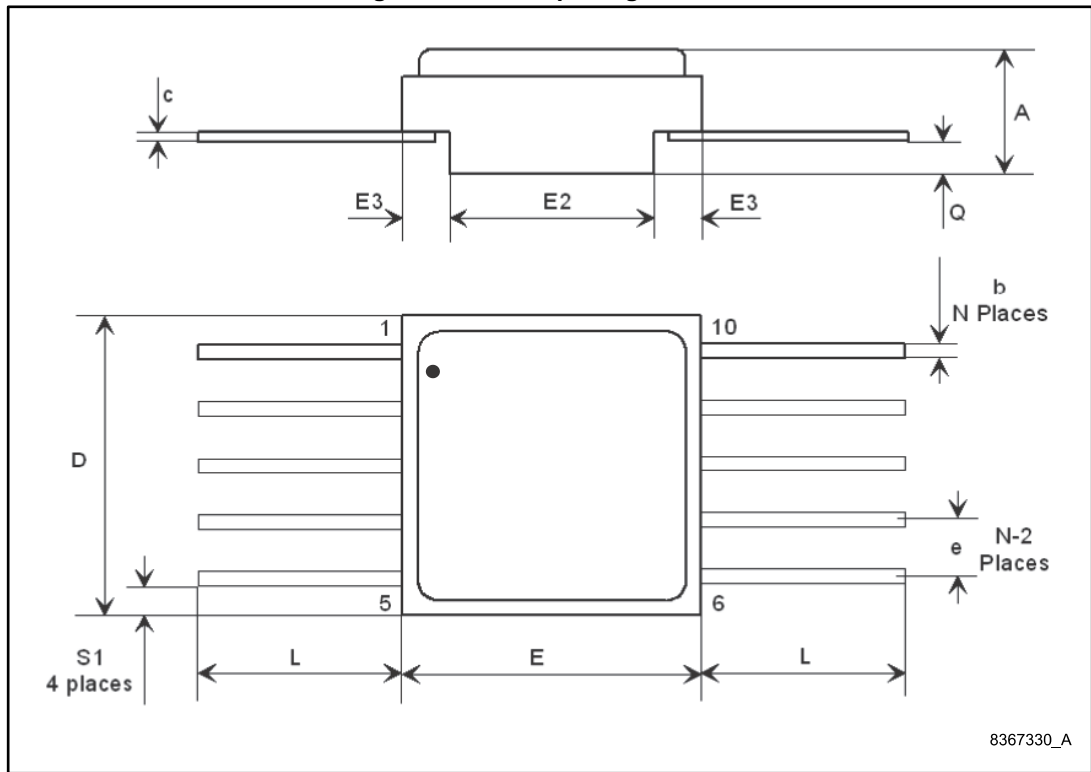

Table 9: Flat-10 package mechanical data

Dim.	mm		
	Min.	Typ.	Max.
A	2.26	2.44	2.62
b	0.38	0.43	0.48
c	0.102	0.127	0.152
D	6.35	6.48	6.60
E	6.35	6.48	6.60
E2	4.32	4.45	4.58
E3	0.88	1.01	1.14
e		1.27	
L	6.35		9.40
Q	0.66	0.79	0.92
S1	0.16	0.485	0.81
N			

## 12 Ordering information

Table 10: Order code

Order code	Quality level	EPPL	Package	Lead finish	Marking <sup>(1)</sup>	Packing
RH-PM4423LK1 <sup>(2)</sup>	Engineering model	-	FLAT-10	Gold	TBD	Strip pack
RH-PM4423K1			FLAT-16			

**Notes:**

<sup>(1)</sup>Specific marking only. The full marking includes in addition: - for the engineering models: ST logo, date code, country of origin (FR) - for QML flight parts: ST logo, date code, country of origin (FR), manufacturer code (CSTM), serial number of the part within the assembly lot.

<sup>(2)</sup> Under development.

Contact ST sales office for information about the specific conditions for:

- 1) Products in die form
- 2) Other quality levels
- 3) Tape and reel packing

## 13 Other information

### 13.1 Data code

The date code is structured as shown below:

- EM xyywwz
- QML-V yywwz where:

Figure 29: Date code composition

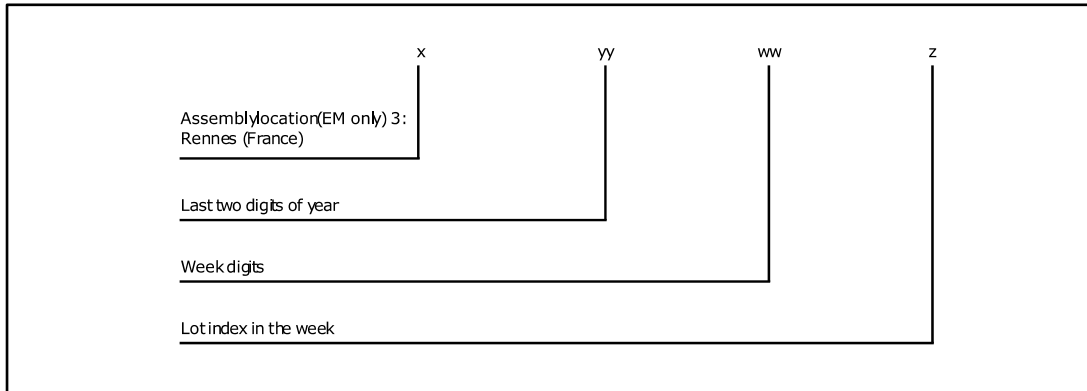

### 13.2 Documentation

Table 11: Documentation provided

Quality level	Documentation
Engineering model	-
QML-V flight	Certificate of conformance with group C (reliability test) and group D (package qualification) reference Precap report PIND <sup>(1)</sup> test summary (test method conformance certificate) SEM <sup>(2)</sup> report X-ray report Screening summary Failed component list, (list of components that have failed during screening) Group A summary (QCI <sup>(3)</sup> electrical test) Group B summary (QCI mechanical test) Group E (QCI wafer lot radiation test)

**Notes:**

- <sup>(1)</sup> QCI = quality conformance inspection.
- <sup>(2)</sup> PIND = particle impact noise detection.
- <sup>(3)</sup> SEM = scanning electron microscope.

## 14 Revision history

Table 12: Document revision history

Date	Revision	Changes
06-Oct-2016	1	Initial version.

**IMPORTANT NOTICE – PLEASE READ CAREFULLY**

STMicroelectronics NV and its subsidiaries ("ST") reserve the right to make changes, corrections, enhancements, modifications, and improvements to ST products and/or to this document at any time without notice. Purchasers should obtain the latest relevant information on ST products before placing orders. ST products are sold pursuant to ST's terms and conditions of sale in place at the time of order acknowledgement.

Purchasers are solely responsible for the choice, selection, and use of ST products and ST assumes no liability for application assistance or the design of Purchasers' products.

No license, express or implied, to any intellectual property right is granted by ST herein.

Resale of ST products with provisions different from the information set forth herein shall void any warranty granted by ST for such product.

ST and the ST logo are trademarks of ST. All other product or service names are the property of their respective owners.

Information in this document supersedes and replaces information previously supplied in any prior versions of this document.

© 2016 STMicroelectronics – All rights reserved