

FEATURES

- +2.5 Volt Output $\pm 0.10\%$ Max
- Low Temperature Coefficient 25ppm/ $^{\circ}\text{C}$ Max
- Excellent Regulation
 - Load Regulation 20ppm/mA Max
 - Line Regulation 2ppm/V Max
- Supply Current 450 μA Max
- Temperature Voltage Output +1.9mV/ $^{\circ}\text{C}$
- Operating Voltage Range +4.5V to +40V
- Extended Industrial Temp Range -40°C to $+85^{\circ}\text{C}$
- Available in Die Form

PIN CONFIGURATION

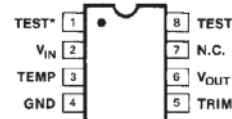

- 8-PIN Cerdip (Z-Suffix)
- 8-PIN Plastic Dip (P-Suffix)
- 8-PIN SO (S-Suffix)

*RESERVED FOR FACTORY TESTING.
MAKE NO ELECTRICAL CONNECTION TO THESE PINS.

GENERAL DESCRIPTION

The REF43 is a low power precision reference providing a stable 2.5 V output independent of variations in supply voltage, load conditions or ambient temperature. It is suitable as a reference level for 8-, 10- and 12-bit data acquisition systems, or wherever a stable, known voltage is required.

Tight output tolerances and low thermal drift are assured by zener-zap trimming of both output voltage and its temperature coefficient. A unique curvature correction circuit reduces the thermal curvature which is characteristic of many previous bandgap references.

ORDERING GUIDE

Model	Initial Accuracy	Temperature Coefficient	Package Description	Package Option	Number of Part per Reel/Tray	Temperature Range
REF43FZ	0.06%	10ppm/ $^{\circ}\text{C}$	8-Pin Hermetic DIP	Q-8	48	-40°C to $+85^{\circ}\text{C}$
REF43GZ	0.10%	25ppm/ $^{\circ}\text{C}$	8-Pin Hermetic DIP	Q-8	48	-40°C to $+85^{\circ}\text{C}$
REF43GP	0.10%	25ppm/ $^{\circ}\text{C}$	8-Pin Plastic DIP	N-8	50	-40°C to $+85^{\circ}\text{C}$
REF43GS	0.10%	25ppm/ $^{\circ}\text{C}$	8-Pin SOIC	R-8	98	-40°C to $+85^{\circ}\text{C}$
REF43GS-REEL	0.10%	25ppm/ $^{\circ}\text{C}$	8-Pin SOIC	R-8	2,500	-40°C to $+85^{\circ}\text{C}$
REF43GS-REEL7	0.10%	25ppm/ $^{\circ}\text{C}$	8-Pin SOIC	R-8	1,000	-40°C to $+85^{\circ}\text{C}$
REF43GSZ*	0.10%	25ppm/ $^{\circ}\text{C}$	8-Pin SOIC	R-8	98	-40°C to $+85^{\circ}\text{C}$
REF43GSZ-REEL7*	0.10%	25ppm/ $^{\circ}\text{C}$	8-Pin SOIC	R-8	1,000	-40°C to $+85^{\circ}\text{C}$
REF43NBC	0.20%		Die		221	

*Z = Pb-free part.

SIMPLIFIED SCHEMATIC

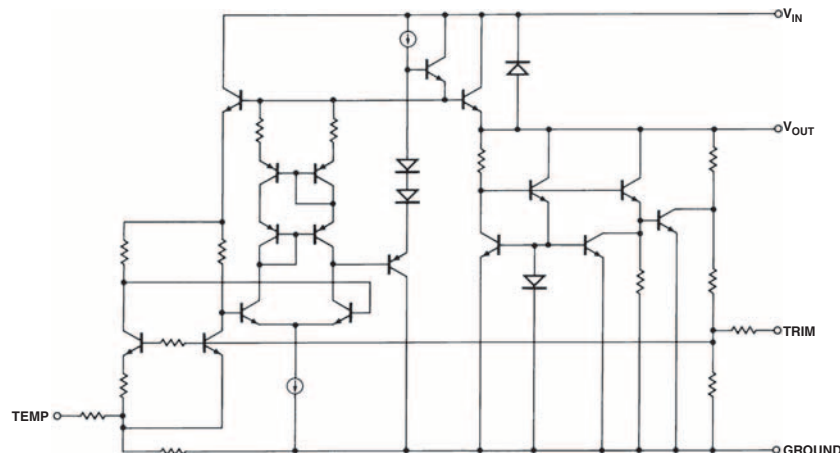

REV. D

Information furnished by Analog Devices is believed to be accurate and reliable. However, no responsibility is assumed by Analog Devices for its use, nor for any infringements of patents or other rights of third parties that may result from its use. No license is granted by implication or otherwise under any patent or patent rights of Analog Devices. Trademarks and registered trademarks are the property of their respective owners.

REF43

The REF-43 may be operated with supply voltages from +4.5V to +40V. The output voltage changes by less than 178 μ V from one extreme of supply voltage to the other. With only 450 μ A maximum quiescent current, the REF-43 is ideally suited to applications where power dissipation must be minimized, as in precision battery-powered equipment. The low supply current minimizes drift due to self-heating after power-up.

A temperature output provides a means of determining system ambient temperature. Applications of the REF-43 include A/D and D/A conversion, 4-20mA transmitter/receiver operation, log amplifiers, and power-supply regulators.

For a low-cost 2.5V reference available in small-outline packages consult the REF-03 data sheet.

ABSOLUTE MAXIMUM RATINGS (Note 1)

Supply Voltage 40V
Output Short-Circuit Duration Indefinite

Operating Temperature Range

REF-43F (J, Z) -40°C to +85°C
REF-43G (J, Z, P, S) -40°C to +85°C
Storage Temperature Range -65°C to +175°C
Junction Temperature Range -65°C to +175°C
Lead Temperature (Soldering, 10 sec) 300°C

PACKAGE TYPE	θ_{JA} (Note 2)	θ_{JC}	UNITS
8-Pin Hermetic DIP (Z)	148	16	°C/W
8-Pin Plastic DIP (P)	103	43	°C/W
8-Pin SO (S)	158	43	°C/W

NOTES:

1. Absolute maximum ratings apply to both DICE and packaged parts, unless otherwise noted.
2. θ_{JA} is specified for worst case mounting conditions, i.e., θ_{JA} is specified for device in socket for TO, CerDIP, P-DIP, and LCC packages; θ_{JA} is specified for device soldered to printed circuit board for SO package.

ELECTRICAL CHARACTERISTICS at $V_{IN} = +5V$, $I_L = 0mA$, $T_A = 25^\circ C$ unless otherwise noted.

PARAMETER	SYMBOL	CONDITIONS	REF-43F			REF-43G			UNITS
			MIN	TYP	MAX	MIN	TYP	MAX	
Output Voltage Tolerance		No Load	—	0.02	0.06	—	0.04	0.1	%
Output Voltage	V_O	No Load	2.4985	2.5000	2.5015	2.4975	2.5000	2.5025	V
Output Voltage Noise	e_{nRMS}	10Hz to 1kHz (Note 1)	—	7	10	—	7	10	μV_{RMS}
Line Regulation		$V_{IN} = +4.5V$ to +40V	—	0.8	2	—	0.8	2	ppm/V
Load Regulation		$I_L = 0mA$ to 10mA	—	14	20	—	14	20	ppm/mA
Quiescent Supply Current	I_{SY}	No Load	—	340	450	—	340	450	μA
Load Current (Sourcing)	I_L	(Note 2)	10	20	—	10	20	—	mA
Load Current (Sinking)	I_S	(Note 3)	—	-1.2	—	—	-1.2	—	mA
Short-Circuit Output Current	I_{SC}	Output Shorted to Ground	—	60	—	—	60	—	mA
Temperature Voltage Output	V_{TEMP}		—	567	—	—	567	—	mV
V_{OUT} Adjust Range			—	± 95	—	—	± 95	—	mV
Long-Term Output Drift	ΔV_O	1,000 Hours	—	40	—	—	40	—	ppm

NOTES:

1. Guaranteed but not tested.
2. Guaranteed by load regulation test.
3. Output remains within 2.5V \pm 2.5mV.

CAUTION

ESD (electrostatic discharge) sensitive device. Electrostatic charges as high as 4000 V readily accumulate on the human body and test equipment and can discharge without detection. Although the REF43 features proprietary ESD protection circuitry, permanent damage may occur on devices subjected to high energy electrostatic discharges. Therefore, proper ESD precautions are recommended to avoid performance degradation or loss of functionality.



ELECTRICAL CHARACTERISTICS at $V_{IN} = +5V$, $I_L = 0mA$, $-40^{\circ}C \leq T_A \leq +85^{\circ}C$ for the REF-43F/G, unless otherwise noted.

PARAMETER	SYMBOL	CONDITIONS	REF-43F			REF-43G			UNITS
			MIN	TYP	MAX	MIN	TYP	MAX	
Output Voltage Tolerance		No Load	-	0.06	0.12	-	0.1	0.2	%
Output Voltage	V_O	No Load	2.497	2.500	2.503	2.495	2.500	2.505	V
Output Voltage Temperature Coefficient	TCV_O	$-55^{\circ}C \leq T_A \leq +125^{\circ}C$ $-40^{\circ}C \leq T_A \leq +85^{\circ}C$ (Note 1)	-	-	-	-	-	-	ppm/ $^{\circ}C$
Line Regulation		$V_{IN} = +4.5V$ to $+40V$	-	1	3	-	1	3	ppm/V
Load Regulation		$I_L = 0mA$ to $10mA$	-	20	35	-	25	40	ppm/mA
Quiescent Supply Current	I_{SY}	No Load	-	400	600	-	400	600	μA
Load Current (Sourcing)	I_L	(Note 2)	10	20	-	10	20	-	mA
Temperature Hysteresis of Output Voltage		$\Delta T = \pm 25^{\circ}C$	-	100	-	-	100	-	μV
Temperature Voltage Output Tempco	TCV_{TEMP}		-	1.9	-	-	1.9	-	mV/ $^{\circ}C$

NOTES:

- Output voltage temperature coefficient is measured by the box method. The tempco is defined as the slope of the diagonal of a box drawn around the output voltage plotted against temperature. V_{OUT} is measured at T_{MIN} , $25^{\circ}C$ and T_{MAX} for the applicable temperature range. The lowest of these three readings is subtracted from the highest reading and the resulting difference is divided by $(T_{MAX} - T_{MIN})$.
- Guaranteed by Load Regulation test.

BURN-IN CIRCUIT

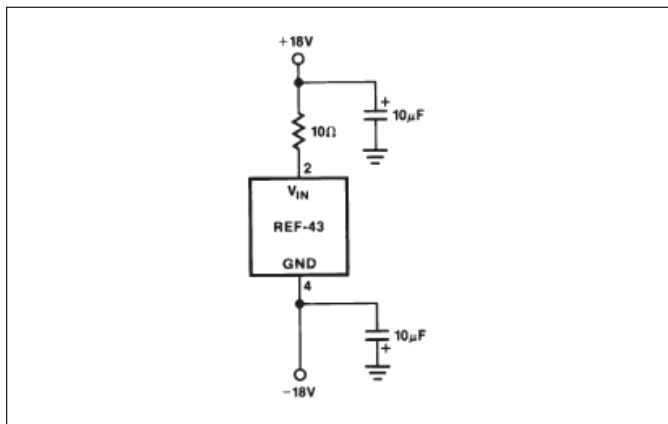

OUTPUT VOLTAGE TRIM METHOD

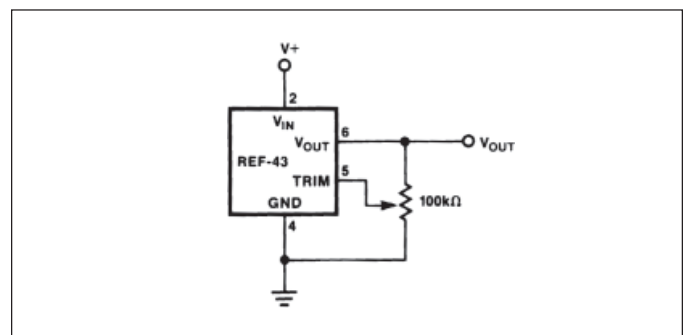

OUTLINE DIMENSIONS

8-Lead Ceramic Dual In-Line Package [CERDIP]
(Q-8)
Z-Suffix

Dimensions shown in inches and (millimeters)

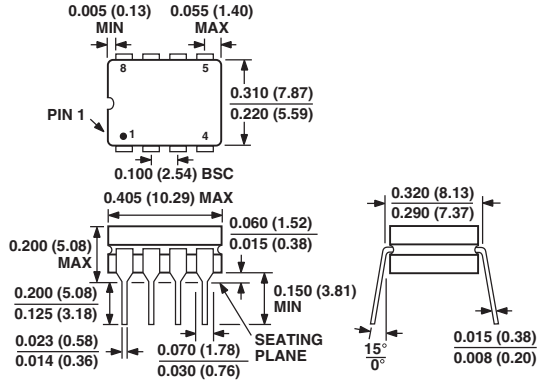

CONTROLLING DIMENSIONS ARE IN INCHES; MILLIMETER DIMENSIONS (IN PARENTHESES) ARE ROUNDED-OFF INCH EQUIVALENTS FOR REFERENCE ONLY AND ARE NOT APPROPRIATE FOR USE IN DESIGN

8-Lead Standard Small Outline Package [SOIC]
(R-8)
S-Suffix

Dimensions shown in millimeters and (inches)

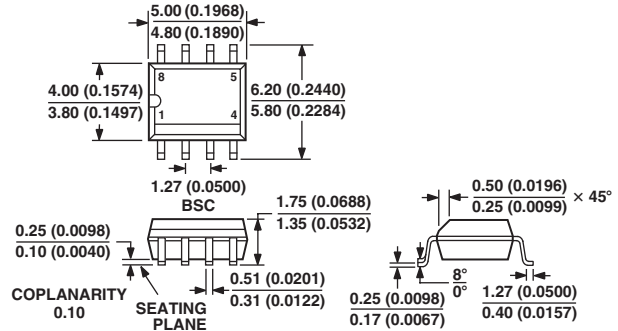

COMPLIANT TO JEDEC STANDARDS MS-012AA
CONTROLLING DIMENSIONS ARE IN MILLIMETERS; INCH DIMENSIONS (IN PARENTHESES) ARE ROUNDED-OFF MILLIMETER EQUIVALENTS FOR REFERENCE ONLY AND ARE NOT APPROPRIATE FOR USE IN DESIGN

8-Lead Plastic Dual In-Line Package [PDIP]
(N-8)
P-Suffix

Dimensions shown in inches and (millimeters)

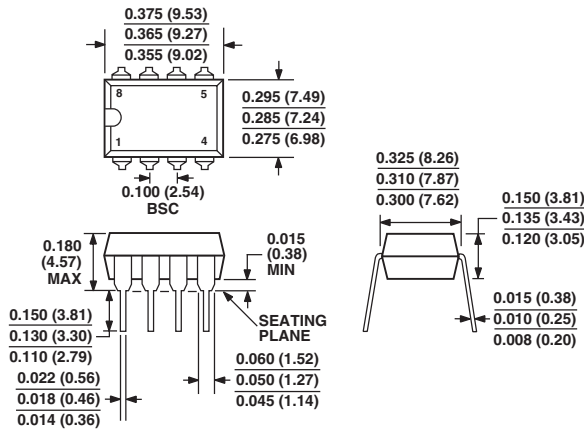

COMPLIANT TO JEDEC STANDARDS MO-095AA
CONTROLLING DIMENSIONS ARE IN INCHES; MILLIMETER DIMENSIONS (IN PARENTHESES) ARE ROUNDED-OFF INCH EQUIVALENTS FOR REFERENCE ONLY AND ARE NOT APPROPRIATE FOR USE IN DESIGN

Revision History

Location	Page
8/04—Data Sheet Changed from REV. C to REV. D.	
Edits to FEATURES	1
Changes to PIN CONFIGURATION	1
Changes to ORDERING GUIDE	1
Changes to ABSOLUTE MAXIMUM RATINGS	2
Changes to PACKAGE TYPE	2
Changes to ELECTRICAL CHARACTERISTICS	2
Deleted PACKAGE TYPE	7