

## Caractéristiques / Characteristics

### Mécanique

- **Boîtiers**
  - Laiton (norme ASTM C 385) traité nickel-chrome satiné
  - Protection des contacts à l'accouplement : 50 % scoop-proof
  - Détrompage à l'accouplement réalisé par 5 clés inamovibles
  - Verrouillage à vis
- **Isolants**
  - Matières suivant arrangements des contacts, voir page 9
- **Contacts**
  - A souder en laiton (norme ASTM C 385) traité nickel-or
- **Joints toriques**
  - Elastomère nitrile
- **Joint de presse-étoupe**  
**Manchon de protection**
  - Elastomère néoprène
- **Endurance**
  - Verrouillage/déverrouillage : 500 cycles
- **Chute libre**
  - Fiche ou prolongateur câblés : < 1,5 m

### Mechanical features

- **Shells**
  - Brass (standard ASTM C 385) nickel-chrome treated
  - Protection of contacts upon mating: 50 % scoop-proof
  - Polarization upon mating performed by 5 unremovable keys
  - Screw-type locking system
- **Insulators**
  - Materials according to contact layout, see page 9
- **Contacts**
  - Solder type in brass (standard ASTM C 385) with nickel-gold plate
- **O-rings**
  - Nitrile elastomer
- **Packing washers - Protection boot**
  - Neoprene elastomer
- **Endurance**
  - 500 locking / unlocking cycles
- **Free-fall**
  - Connecting plug or plug harness < 1.5 m

### Electrique / Electrical

- **Tension de tenue**  
suivant arrangements des contacts, voir page 9
- **Withstanding voltage**  
according to the contact layout, see page 9

Classe de tension Voltage category	Tension de service (Veff 50 Hz) Service voltage (Vrms 50 Hz)	Tension de tenue (Veff 50 Hz) Withstanding voltage (Vrms 50 Hz)
Service 1	600	1500
Service 2	1000	2300
Service 3	7000	15 000

- **Intensité admissible - Résistance de contact**
- **Current rating - Contact resistance**

Taille de boîtier Shell size	Type de contact Type of contact	high voltage	Intensité maxi par contact (A) Max. current per contact (A)
8TP 10TP 14TP 20TP	20		7
	16		14
	14		20
	12		26
	6		65
10TP	2		115
	coaxial 50 Ω		20
	coaxial 75 Ω		7
10TP	triaxial 50 Ω		7
20TP	coaxial 50 Ω		
10TP	triaxial 75 Ω		4
20TP	coaxial 75 Ω		
14TP	coaxial 50 Ω		40
	triaxial 50 Ω		26
	triaxial 75 Ω		14
10TP- 14TP	haute tension high voltage		14
20TP	haute tension		20

- **Résistance d'isolement**
  - Connecteurs désaccouplés :  $\geq 10^4 M\Omega$
  - Connecteurs accouplés :  $\geq 5 \cdot 10^3 M\Omega$  sous 500 Vcc
- **Résistance de mise à la masse**
  - Connecteurs accouplés entre la platine de l'embase et la tresse du câble de la fiche :  $\leq 10 m\Omega$
- **Insulation resistance**
  - Unmated connectors:  $\geq 10^4 M\Omega$
  - Mated connectors:  $\geq 5 \times 10^3 M\Omega$  on 500 Vcc
- **Shielding**
  - Connectors mated: measurement between the receptacle plate and the plug's cable braid:  $\leq 10 m\Omega$

### Environnement

- **Température d'utilisation**  
-20°C à +70°C
- **Etanchéité**
  - Connecteurs désaccouplés : 10 bar essai, 5 bar service
  - Connecteurs accouplés : 60 bar essai, 30 bar service
- **Brouillard salin**
  - 20 cycles de 24 heures
- **Vibrations**
  - de 0,1 Hz à 1 Hz : amplitude = 25 mm
  - de 1 Hz à 5 Hz : accélération = 0,1 g
  - de 5 Hz à 22 Hz : amplitude = 1 mm
  - de 22 Hz à 50 Hz : accélération = 2 g pendant 1 heure sur chaque axe
- **Chocs**
  - Accélération statique 120 g sur chaque axe
- **Tenue aux fluides**
  - Huiles, alcools, pétrole, fioul, eau de mer
  - Divers gaz (naturel, butane, propane, fréon)
  - Divers acides (acétique, borique, citrique)





### Environmental

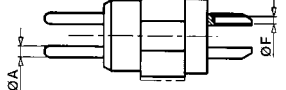

- **Operating temperature range**  
- from -20 °C to +70 °C
- **Watertightness**
  - Unmated connectors: 145 PSI for tests, 72,5 PSI for service
  - Mated connectors: 870 PSI for tests, 435 PSI for service
- **Salt spray**
  - 20 cycles of 24 hours
- **Vibrations**
  - from 0.1 Hz to 1 Hz : amplitude = 25 mm
  - from 1 Hz to 5 Hz : acceleration = 0,1 g
  - from 5 Hz to 22 Hz : amplitude = 1 mm
  - from 22 Hz to 50 Hz : acceleration = 2 g duration 1 hour on each axis
- **Shocks**
  - Static acceleration of 120 g on each axis
- **Fluids resistance**
  - Oil, alcohol, petrol, diesel fuel, sea water
  - Various gases (natural, butane, propane, freon)
  - Various acids (acetic, boric, citric)

# TP series

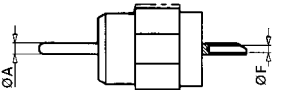

## Contacts / Contacts

Taille de boîtier <i>Shell size</i>	Taille de contact <i>Size of contact</i>	Ø A (mm) avant du contact <i>Front of contact</i>	Ø F (mm) intérieur du fût à souder <i>Inside the solder bucket</i>	Ame conductrice admissible (AWG) / section (mm²) <i>Conductive core authorized AWG / cross-section (mm²)</i>	Contact démontable <i>Removable contact</i>	Définition <i>Definition</i>	
8TP	20	1,02	0,9	26 / 0,14 à/to 22 / 0,38	Non / No	mâle <i>pin</i> 	
	16	1,59	1,2	24 / 0,21 à/to 20 / 0,60			
10TP	20	1,02	0,9	26 / 0,14 à/to 22 / 0,38		femelle <i>socket</i> 	
	16	1,59	1,4	22 / 0,38 à/to 18 / 0,93			
14TP	14	1,93	1,9	18 / 0,93 à/to 16 / 1,34		Oui / Yes	mâle <i>pin</i>  femelle <i>socket</i> 
20TP	12	2,39	2,3	16 / 1,34 à/to 14 / 1,91			
	6	5	6,2	8 / 8,98 à/to 6 / 13,4			
	2	7	9	4 / 21,8 à/to 2 / 34,5			

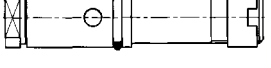
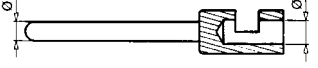
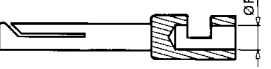
Taille de boîtier <i>Shell size</i>	Taille de contact <i>Size of contact</i>	Ø A (mm) avant du contact <i>Front of contact</i>	Ø F (mm) intérieur du fût à souder <i>Inside the solder bucket</i>	Câble admissible et norme <i>Acceptable cable and specifications</i>	Contact démontable <i>Removable contact</i>	Définition <i>Definition</i>
10TP	Coaxial 50Ω	1,93	2,4	KX 4 - KX 15 - NFC 93550 RG 213 U - RG 58 CU - MIL C 17 F	Non / No	mâle <i>pin</i>  femelle <i>socket</i> 
	Coaxial 75Ω	1,02	1,5	KX 6A - KX 8 - NF C 93550 RG 59 BU - RG 11 AU - MIL C 17 F		
14 TP	Coaxial 50Ω	4	3	KX 13 - NF C 93550 MIL C 17 F - RG 217U	Oui / Yes	mâle <i>pin</i>  femelle <i>socket</i> 
10TP	Triaxial 50Ω	0,9	1,2	KX 15 - NF C 93550 MIL C 17 F - RG 58 CU		
20TP	Coaxial 50Ω					
10TP	Triaxial 75Ω	0,7	0,8	KX 6A - NF C 93550 MIL C 17 F - RG 59 BU		
20TP	Coaxial 75Ω					
14TP	Triaxial 50Ω	3	2,6	Suivant accessoires serre-câbles, voir page 12	Non / No	mâle <i>pin</i>  femelle <i>socket</i> 
		Triaxial 75Ω	1,59	1,2		
10TP	Haute tension	1,59	2	Marine cable DSM 40		
14TP	High voltage			Marine cable DSM 41		
20TP	Haute tension	2	1,3	Marine cable DSM 37		

# TP series



## Arrangements des contacts (vue côté enfichage de l'isolant mâle) Pin layouts (viewed from male insulator mating side)

8TP																					
 <p><b>4 contacts</b> taille / size <b>16</b></p>	<p>Isolant / Insulator : <b>N</b> Arrangement / Pin layout : <b>04-16</b> Serre-câble / Cable clamp : <b>A ou/or U</b> Tension / Voltage : <b>service 2</b></p>	 <p><b>7 contacts</b> taille / size <b>20</b></p>	<p>Isolant / Insulator : <b>N</b> Arrangement / Pin layout : <b>07-20</b> Serre-câble / Cable clamp : <b>A ou/or U</b> Tension / Voltage : <b>service 1</b></p>																		
10TP																					
 <p><b>3 contacts</b> taille / size <b>20</b></p>	<p>Isolant / Insulator : <b>T</b> Arrangement / Pin layout : <b>03-20</b> Serre-câble / Cable clamp : <b>A ou/or U</b> Tension / Voltage : <b>service 2</b></p>	 <p><b>7 contacts</b> taille / size <b>20</b></p>	<p>Isolant / Insulator : <b>N ou/or T</b> Arrangement / Pin layout : <b>07-20</b> Serre-câble / Cable clamp : <b>A ou/or U</b> Tension / Voltage : <b>service 1</b></p>																		
 <p><b>4 contacts</b> taille / size <b>16</b></p>	<p>Isolant / Insulator : <b>N ou/or T</b> Arrangement / Pin layout : <b>04-16</b> Serre-câble / Cable clamp : <b>A ou/or U</b> Tension / Voltage : <b>service 2</b></p>	 <p><b>5 contacts</b> taille / size <b>16</b></p>	<p>Isolant / Insulator : <b>N ou/or T</b> Arrangement / Pin layout : <b>05-16</b> Serre-câble / Cable clamp : <b>A ou/or U</b> Tension / Voltage : <b>service 1</b></p>																		
 <p><b>2 contacts</b> taille / size <b>14</b></p>	<p>Isolant / Insulator : <b>N ou/or T</b> Arrangement / Pin layout : <b>02-14</b> Serre-câble / Cable clamp : <b>A ou/or U</b> Tension / Voltage : <b>service 2</b></p>	 <p><b>3 contacts</b> taille / size <b>14</b></p>	<p>Isolant / Insulator : <b>N ou/or T</b> Arrangement / Pin layout : <b>03-14</b> Serre-câble / Cable clamp : <b>A ou/or U</b> Tension / Voltage : <b>service 2</b></p>																		
 <p><b>1 coax.</b> <b>50Ω ou/or 75Ω</b></p>	<p>Isolant / Insulator : <b>T</b> Arrangement / Pin layout : <b>1C-50 ou/or 1C-75</b> Serre-câble / Cable clamp : <b>U</b> Tension / Voltage : <b>service 1</b></p>	 <p><b>1 triax.</b> <b>50Ω ou/or 75Ω</b></p>	<p>Isolant / Insulator : <b>K</b> Arrangement / Pin layout : <b>TX-50 ou/or TX-75</b> Serre-câble / Cable clamp : <b>A</b> Tension / Voltage : <b>service 1</b></p>																		
 <p><b>1 high voltage contact</b></p>	<p>Isolant / Insulator : <b>T et/and S (1)</b> Arrangement / Pin layout : <b>01-HT</b> Serre-câble / Cable clamp : <b>K</b> Tension / Voltage : <b>service 3</b></p>	<p>MATIERES ISOLANT / INSULATING MATERIALS : N : Nylatron (PA6/6+MOS2) - T : Teflon (PTFE) K : Kel'F (PCTFE) - S : Silicone (FMQ) (1) : isolant silicone pour la fiche/silicone insulator for the plug</p> <p>Type de contact / Contact type :</p> <table style="width: 100%; text-align: center;"> <tr> <td>20</td> <td>16</td> <td>14</td> <td>12</td> <td>6</td> <td>2</td> <td>Haute tension High voltage</td> <td>Coax. Coax.</td> <td>Triax. Triax.</td> </tr> <tr> <td></td> <td></td> <td></td> <td></td> <td></td> <td></td> <td></td> <td></td> <td></td> </tr> </table>		20	16	14	12	6	2	Haute tension High voltage	Coax. Coax.	Triax. Triax.									
20	16	14	12	6	2	Haute tension High voltage	Coax. Coax.	Triax. Triax.													
																					

# TP series

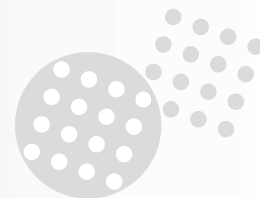

## Accessoires serre-câbles / Cable clamp accessories

### Standard / Standard

Référence Reference	Description Description	Câble admissible diamètre extérieur (mm) Acceptable cable external diameter			
		8TP	10TP	14TP	20TP
<b>A</b>	Pince serre-câble Cable clamp	Ø 4 à / to Ø 6,2	Ø 5 à / to Ø 11	Ø 9 à / to Ø 16	Ø 16 à / to Ø 26
<b>U</b>	Pince serre-câble Reprise de tresse de masse reliée au boîtier Cable clamp Ground braid linked to shell	Ø 4 à / to Ø 6,2 (1)	Ø 5 à / to Ø 11 (1)	Ø 9 à / to Ø 16 (1)	Ø 16 à / to Ø 26 (1)

### Spécifiques (sur demande) / Specials (on request)

Référence Reference	Description Description	Câble admissible diamètre extérieur (mm) Acceptable cable external diameter		
		10TP	14TP	20TP
<b>JA</b>	Serre-câble pour triaxial Reprise de tresse de masse isolée du boîtier Cable clamp for triaxial cable Ground braid connection isolated from the shell	/	Ø16 maxi <b>50 Ω</b> (KX 4 - KX 15 - NF C 93550) (RG 213 U - RG 58 CU - MIL C 17 F) (marine cable DSM 40) <b>75 Ω</b> (KX 8 - NF C 93550) (RG 11 AU - RG 6 AU - MIL C 17 F)	/
<b>JB</b>	Serre-câble pour triaxial Reprise de tresse de masse isolée du boîtier Reprise de tresse armure reliée au boîtier Cable clamp for triaxial cable Ground braid connection isolated from the shell Armor braid linked to shell	/	Ø16 maxi <b>50 Ω</b> (50 MP - 6145 CA) (marine cable DSM 41) <b>75 Ω</b> (75 MP - 6145 CA)	/
<b>K</b>	Serre-câble pour haute tension Reprise de tresse de masse reliée au boîtier Reprise de tresse armure (taille 14TP uniquement) Cable clamp for high voltage cable Ground braid linked to shell Armor braid connection (size 14TP only)	Ø 11,3 maxi	Ø14,3 maxi	/
<b>M</b>	Douille serre-câble Reprise de tresse armure reliée au boîtier Cable clamping sleeve	/	Ø 9 à / to Ø 16	Ø 16 à / to Ø 22

(1) Diamètre maximum admissible avec reprise de tresse masse : diamètre sur tresse de masse rabattu sur la gaine extérieure du câble  
(1) Maximum diameter acceptable with grounding braid: with braid diameter turned down cable external sheath

# TP series



## Accessoires serre-câbles / Cable clamp accessories

Boîtiers Shell size	8TP - 10TP - 14TP - 20TP													
Accessoire Accessory														
	<p>SERRAGE VOIR OUTILLAGE PAGE 28 CLAMPING, SEE TOOLING ON PAGE 28</p>													
A & U														
	<p>Nota : Dénudage pour arrangements avec contacts de taille 20 à 12, 1C-50, 1C-75 Stripping for inserts with contacts size from 20 to 12, 1C-50, 1C-75</p>													
	<table border="1"> <thead> <tr> <th>Boîtier</th> <th>8TP</th> <th>10TP</th> <th>14TP</th> <th>20TP</th> </tr> </thead> <tbody> <tr> <td>A</td> <td>13</td> <td>17</td> <td>19</td> <td>21</td> </tr> </tbody> </table>				Boîtier	8TP	10TP	14TP	20TP	A	13	17	19	21
Boîtier	8TP	10TP	14TP	20TP										
A	13	17	19	21										
Boîtier Shell size	14TP													
Accessoire Accessory														
	<p>SERTISSAGE VOIR OUTILLAGE PAGE 25 CRIMPING, SEE TOOLING ON PAGE 25</p>													
JA	<p>ØD &lt; 10.6</p>		<p>ØD ≥ 10.6</p>											
			<table border="1"> <thead> <tr> <th>Impédance</th> <th>Ø A</th> </tr> </thead> <tbody> <tr> <td>50 Ω</td> <td>2,6</td> </tr> <tr> <td>75 Ω</td> <td>1,2</td> </tr> </tbody> </table>		Impédance	Ø A	50 Ω	2,6	75 Ω	1,2				
Impédance	Ø A													
50 Ω	2,6													
75 Ω	1,2													
			<table border="1"> <thead> <tr> <th>Ø D</th> <th>L</th> </tr> </thead> <tbody> <tr> <td>&lt; 10,6</td> <td>30</td> </tr> <tr> <td>≥ 10,6</td> <td>36</td> </tr> </tbody> </table>		Ø D	L	< 10,6	30	≥ 10,6	36				
Ø D	L													
< 10,6	30													
≥ 10,6	36													

# TP series



Boîtier Shell size	14TP												
<p>Accessoire Accessory</p> <p><b>JB</b></p>	<table border="1" data-bbox="1125 952 1433 1057"> <thead> <tr> <th>Impédance</th> <th>Ø A</th> </tr> </thead> <tbody> <tr> <td>50 Ω</td> <td>2,6</td> </tr> <tr> <td>75 Ω</td> <td>1,2</td> </tr> </tbody> </table> <table border="1" data-bbox="1125 1079 1433 1187"> <thead> <tr> <th>Ø D</th> <th>L</th> </tr> </thead> <tbody> <tr> <td>&lt; 10,6</td> <td>30</td> </tr> <tr> <td>≥ 10,6</td> <td>36</td> </tr> </tbody> </table>	Impédance	Ø A	50 Ω	2,6	75 Ω	1,2	Ø D	L	< 10,6	30	≥ 10,6	36
Impédance	Ø A												
50 Ω	2,6												
75 Ω	1,2												
Ø D	L												
< 10,6	30												
≥ 10,6	36												
Boîtier Shell size	10TP												
<p>Accessoire Accessory</p> <p><b>K</b></p>													

# TP series



## Encombremments des boîtiers / Shell dimensions

RER - Embase à fixation par écrou étanche au panneau

RER - Jam-nut receptacle, watertight mounting

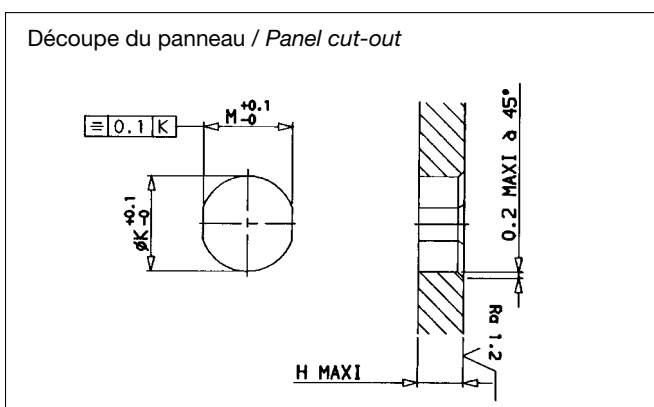
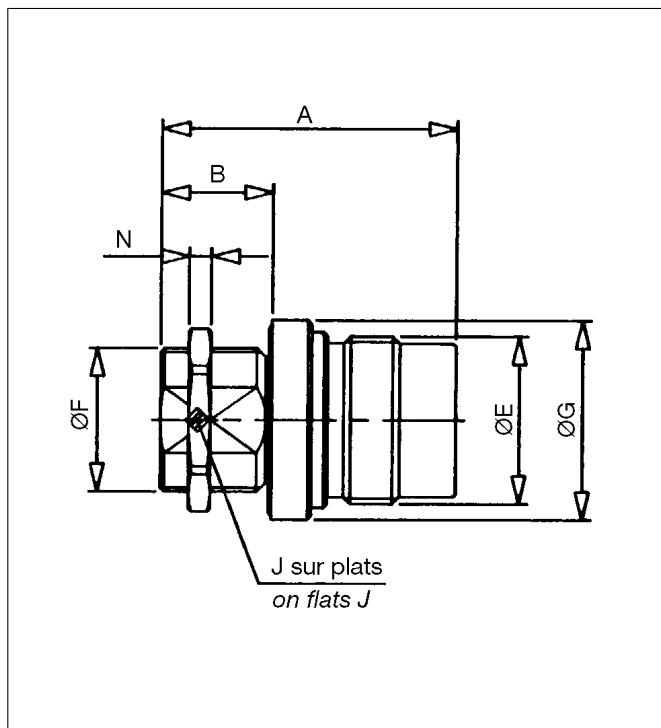

Taille de boîtier Shell size	8TP	10TP	14TP	20TP
A	23	37	37	49,5
B	8,5	14	13	17
Ø E	M17 x 1	M21 x 1	M29 x 1	M41 x 1
Ø F	M14 x 0,75	M18 x 0,75	M25 x 0,75	M36 x 1
Ø G	20	25	34	46
H maxi	5	10	9	12
J sur plats / on flats J	17	22	30	41
Ø K $^{+0,1}_0$	14,2	18,2	25,2	36,2
M $^{+0,1}_0$	13,2	16,2	23,2	33,2
N	3	4	4	5
Référence - P/N	□□ □□	RERΔ10TP▲□□-□□	RERΔ14TP▲□□-□□	RERΔ20TP▲□□-□□

Δ = F (Femelle) pour arrangements 01-HT et 04-HT

Δ = F (Female) for 01-HT and 04-HT pin layouts

# TP series



## Encombremments des boîtiers / Shell dimensions

REC - Embase à fixation par vis étanche au panneau

REC - Square flange receptacle, watertight mounting

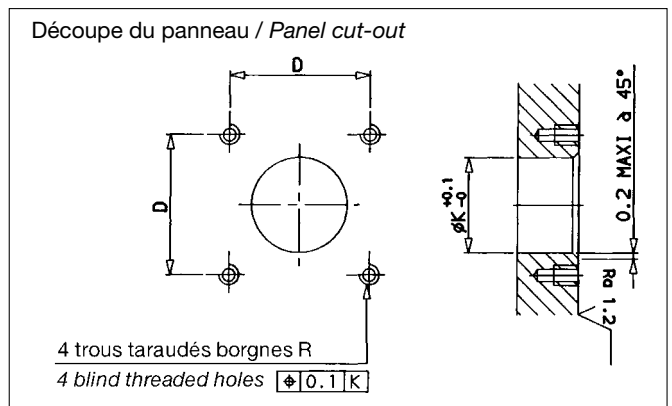
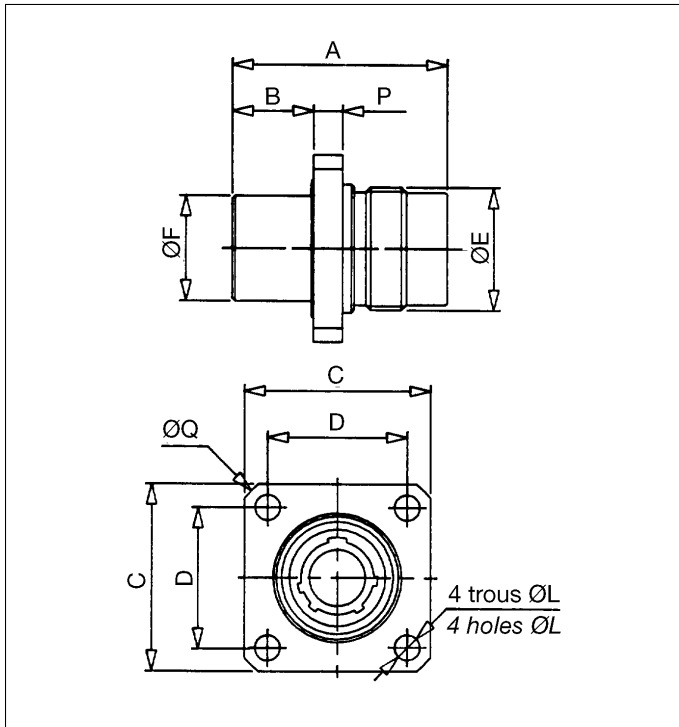

Taille de boîtier Shell size	8TP	10TP	14TP	20TP
A	23	37	37	49,5
B	4	14	13	17
C	23	32	40	52
D	17,5	24	31	42
Ø E	M17 x 1	M21 x 1	M29 x 1	M41 x 1
Ø F	14	18	25	36
Ø K $^{+0.1}_0$	14,2	18,2	25,2	36,2
Ø L	3,2	4,3	5,3	6,3
P	3	5	6	8
Ø Q maxi	31,5	42,5	53,5	70,5
R	M3	M4	M5	M6
Référence - P/N	□□ □□	RECΔ10TP▲□□-□□	RECΔ14TP▲□□-□□	RECΔ20TP▲□□-□□

Δ = F (Femelle) pour arrangements 01-HT et 04-HT

Δ = F (Female) for 01-HT and 04-HT pin layouts

# TP series



## Encombremments des boîtiers / Shell dimensions

TER - Traversée à fixation par écrou étanche au panneau

TER - Jam-nut bulkhead, watertight mounting

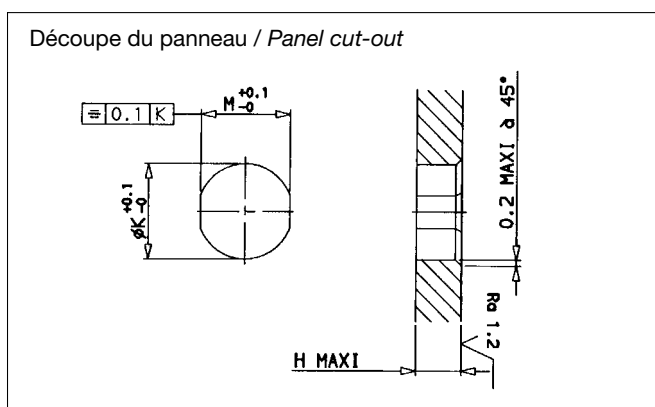
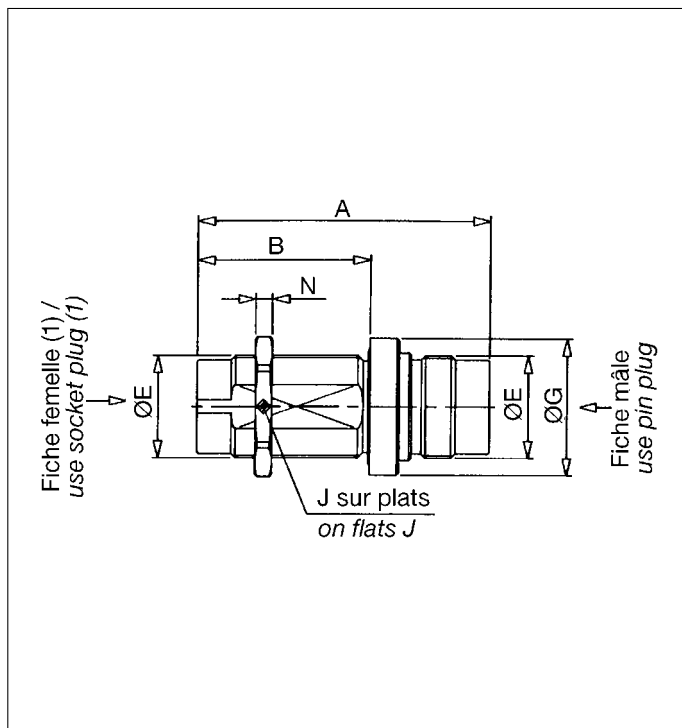

Taille de boîtier Shell size	8TP	10TP	14TP	20TP
A	50	60	60	82
B	34,5	35,5	34,5	47,5
Ø E	M17 x 1	M21 x 1	M29 x 1	M41 x 1
Ø G	23	28	40	52
H maxi	19	16	13	22
J sur plats / on flats J	20	24	34	46
Ø K $^{+0,1}_0$	17,2	21,2	29,2	41,2
M $^{+0,1}_0$	14,2	19,2	27,2	39,2
N	4	4	6	5
Référence - P/N	□□ □□	TER110TPT□□-□□ <sup>(1)</sup>	TER114TPT □□-□□	TER120TPT □□-□□

Certains arrangements de contacts ne sont pas disponibles pour les traversées, nous consulter.  
 Certain pin layouts are not available for bulkhead. Call us for more information.

(1) Sauf arrangement 01-HT (contact femelle/femelle). Référence traversée : TER210TPT01-HT. Fiche mâle des deux côtés.

(1) Except pin layout 01-HT (female/female contact). Bulkhead P/N : TER210TPT01-HT. Male plug on both sides.

# TP series

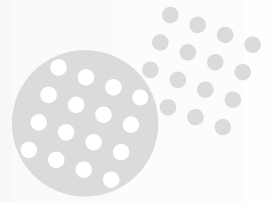

## Encombremments des boîtiers / Shell dimensions

TEC - Traversée à fixation par vis étanche au panneau

TEC - Square flange bulkhead, watertight mounting

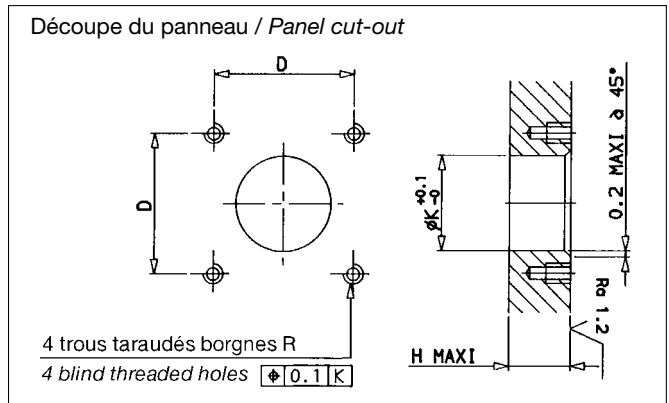
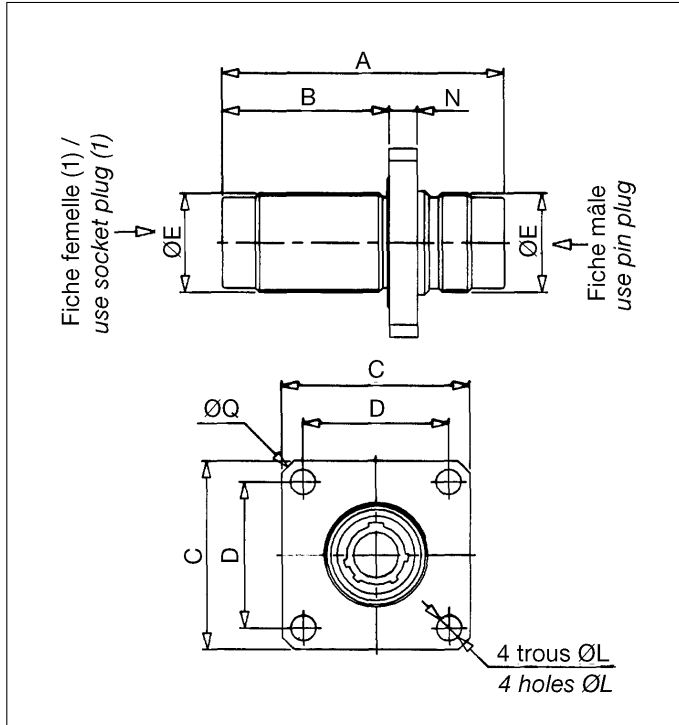

Taille de boîtier Shell size	8TP	10TP	14TP	20TP
A	50	60	60	82
B	34,5	35,5	34,5	47,5
C	32	40	52	76
D	24	31	42	60
Ø E	M17 x 1	M21 x 1	M29 x 1	M41 x 1
H maxi	23	20	19	27
Ø K <sup>+0.1</sup> <sub>0</sub>	17,2	21,2	29,2	41,2
Ø L	4,3	5,3	6,3	8,5
P	4	6	8	9
Ø Q maxi	42,5	53,5	70,5	100,5
R	M4	M5	M6	M8
Référence - P/N	TEC18TPK □□-□□	□□ □□ (1)	TEC114TPT□□-□□	TEC120TPT □□-□□

Certains arrangements de contacts ne sont pas disponibles pour les traversées, nous consulter.  
Certain pin layouts are not available for bulkhead. Call us for more information.

(1) Sauf arrangement 01-HT (contact femelle/femelle). Référence traversée : TEC210TPT01-HT. Fiche mâle des deux côtés.

(1) Except pin layout 01-HT (female/female contact). Bulkhead P/N : TEC210TPT01-HT. Male plug on both sides.

# TP series



## Encombremments des boîtiers / Shell dimensions

RECSC - Prolongateur à fixation par vis étanche au panneau

RECSC - Square flange in-line receptacle, watertight mounting

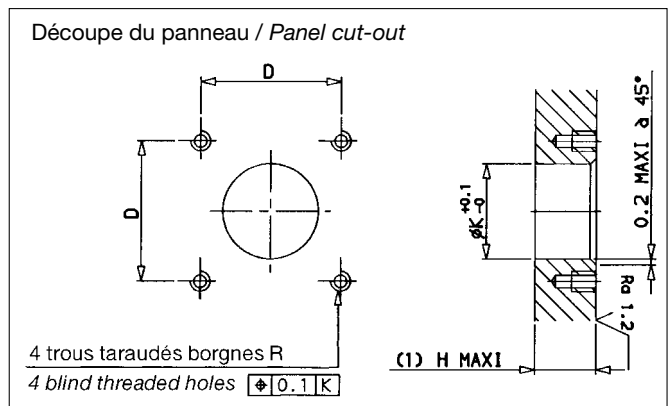
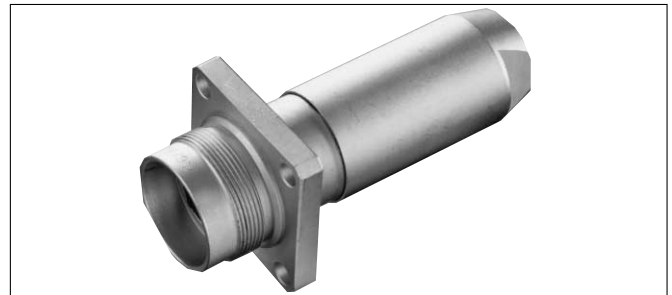
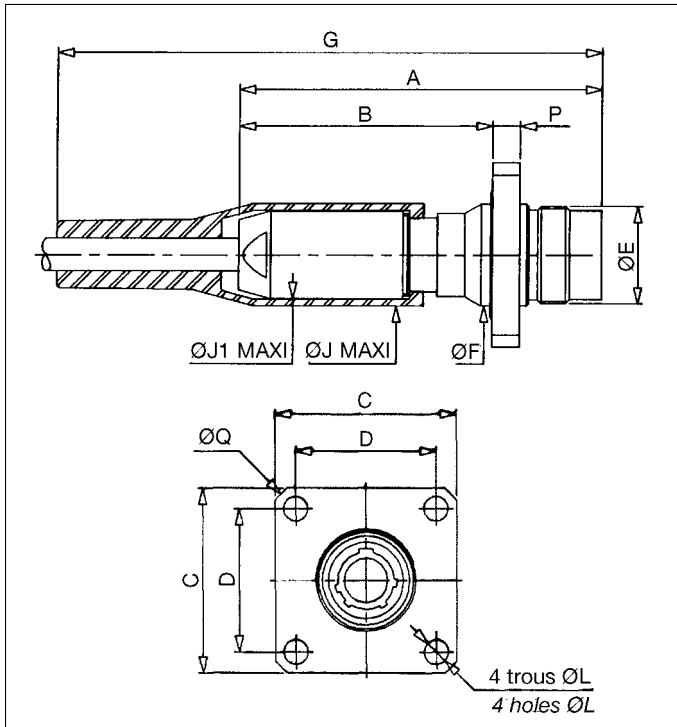

Taille de boîtier/Shell size	8TP	10TP	14TP	20TP
A	57	82	100	126
B	42	58	76	96
C	32	40	52	76
D	24	31	42	60
Ø E	M17 x 1	M21 x 1	M29 x 1	M41 x 1
Ø F	18	22	29	41
G	83	119	153	198
H maxi	10	12	12	20
Ø J maxi	20	23	32	45
Ø J1 maxi	17	20	27	39
Ø K $^{+0.1}_0$	18,2	22,2	29,2	41,2
Ø L	4,3	5,3	6,3	8,5
P	4	8	8	9
Ø Q maxi	42,5	53,5	70,5	100,5
R	M4	M5	M6	M8
Référence - P/N	RECSCΔ8TPN □□□□■○○○	RECSCΔ10TP▲□□□■○○○	RECSCΔ14TP▲□□□■○○○	RECSCΔ20TP▲□□□■○○○

Nota : Mise en place du manchon de protection après fixation du prolongateur sur le panneau  
 Note : Only fit the protection boot after securing connector fixing onto panel.

(1) Pour mise en place du manchon de protection / (1) For installing the protection boot.

Δ = F (Femelle) pour arrangement 01-HT

Δ = F (Female) for 01-HT pin layout.

# TP series



## Encombremments des boîtiers / Shell dimensions

### FED - Fiche droite / FED - Straight plug

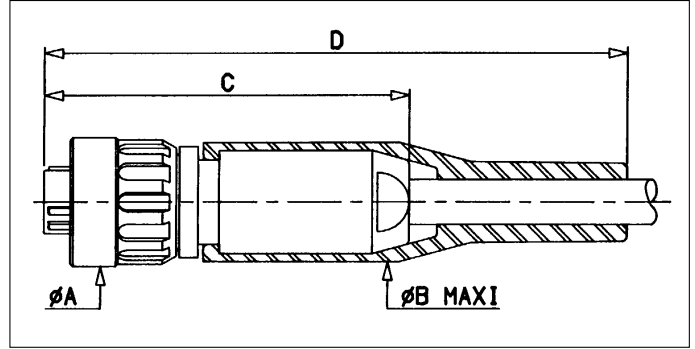

Taille de boîtier/Shell size	8TP	10TP	14TP	20TP
Ø A	20	25	34	46
Ø B maxi	20	23	32	45
C	53	72	90	114
D	79	110	144	186
Référence - P/N	FED $\Delta$ 8TPN□□ - □□■○○	FED $\Delta$ 10TP▲□□ - □□■○○	FED $\Delta$ 14TP▲□□ - □□■○○	FED $\Delta$ 20TP▲□□ - □□■○○

$\Delta$  = M (Mâle) pour arrangements 01-HT et 04-HT

$\Delta$  = M (Male) for 01-HT and 04-HT pin layouts

### PCE - Prolongateur / PCE - Cable connecting plug

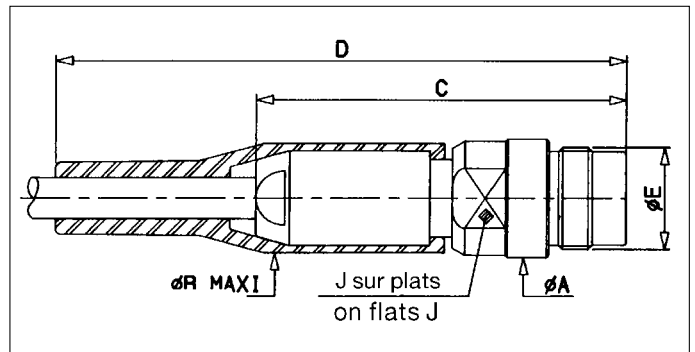

Taille de boîtier/Shell size	8TP	10TP	14TP	20TP
Ø A	20	25	34	46
Ø B maxi	20	23	32	45
C	57	82	100	126
D	83	119	153	198
Ø E	M17 x 1	M21 x 1	M29 x 1	M41 x 1
J sur plats / on flats J	17	20	28	38
Référence - P/N	PCE $\Delta$ 8TPN□□ - □□■○○	PCE $\Delta$ 10TP▲□□ - □□■○○	PCE $\Delta$ 14TP▲□□ - □□■○○	PCE $\Delta$ 20TP▲□□ - □□■○○

$\Delta$  = F (Femelle) pour arrangement 01-HT

$\Delta$  = F (Female) for 01-HT pin layout

# TP series

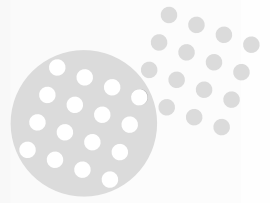

## Bouchons / Caps

**BEF - Bouchon étanche de fiche**  
**BEF - Plug sealing cap**

**BER - Bouchon étanche d'embase**  
**BER - Receptacle sealing cap**

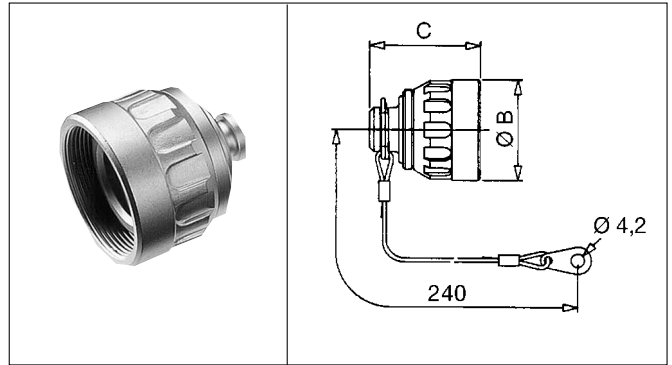
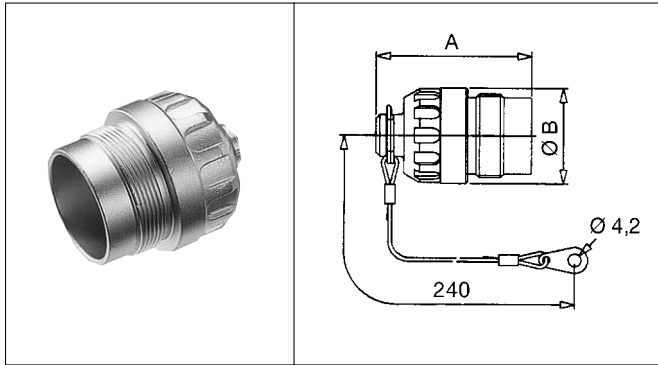

Taille de boîtier/Shell size	8TP	10TP	14TP	20TP
A	30	39	40	51
Ø B	20	25	34	46
C	27	34	34	48,5
Référence sans cordelette <i>P/N without cord</i>	BEF 8TP BER 8TP	BEF 10TP BER 10TP	BEF 14TP BER 14TP	BEF 20TP BER 20TP
Référence avec cordelette <i>P/N with cord</i>	BEFC 8TP BERC 8TP	BEFC 10TP BERC 10TP	BEFC 14TP BERC 14TP	BEFC 20TP BERC 20TP

## Connecteurs accouplés/désaccouplés

**Mated/unmated connectors**

**FED avec RER, REC, TER, TEC ou RECSC**  
**FED with RER, REC, TER, TEC or RECSC**

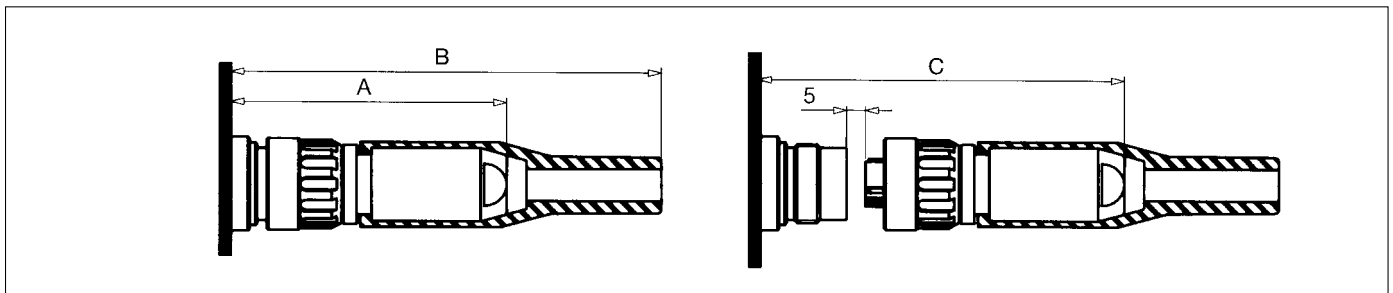

Taille de boîtier/Shell size	8TP	10TP	14TP	20TP
A	59	77	96	123
B	85	115	150	195
C	75	101	120	153

# TP series

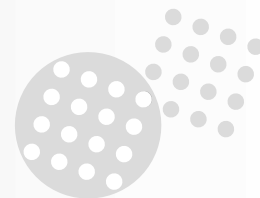

## Références des blocs isolants / Part numbers for insulating blocks

Pour FED, PCE et RECSC uniquement

Pour RER, REC, TER et TEC le remplacement des blocs isolants n'est pas recommandé (absence de test d'étanchéité)

For FED, PCE and RECSC only

For RER, REC, TER and TEC, replacement of the insulating blocks is not recommended (no sealing test carried-out)

Bloc isolant / Insulating block	<b>BIS</b>	<b>14TP</b>	<b>N</b>	□□-□□	△
Taille de boîtier / Shell size : 8TP - 10TP - 14TP - 20TP					
Isolant nylatron / Nylatron insulator					
Arrangements des contacts, voir page 9 / Pin layouts (see page 9)					
Sexe des contacts : M = mâle - F = femelle / Contacts : M = male - F = female					

Bloc isolant / Insulating block	<b>BIS</b>	<b>14M</b>	▲	□□-□□	△
Taille de boîtier / Shell size : 10M - 14M - 20M					
Matière de l'isolant : T = téflon, K = kel'f suivant arrangements des contacts, voir page 9					
Insulating material : T = teflon, K = kel'f according to layouts, see page 9					
Arrangements des contacts, voir page 9 / Pin layouts (see page 9)					
Sexe des contacts : M = mâle - F = femelle / Contacts : M = male - F = female					

Nous consulter pour les arrangements

Please contact us for the following pin layouts

10TP : 01-HT

14TP : 01-HT, 1C-50, TX-50 et/and TX-75

20 TP : 04-HT

## Références des manchons de protection

### Part numbers for protection boots

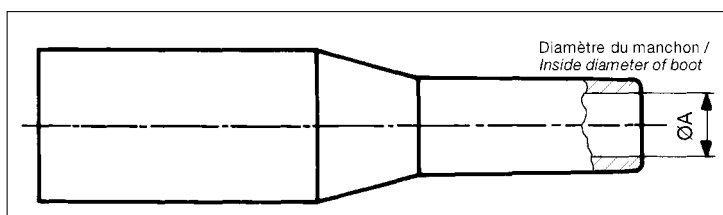

Taille de boîtier / Shell size	8TP	10TP	14TP	20TP
Câble admissible / Acceptable cable Ø A Référence - P/N	Ø 4 à/to Ø 6,2 5,3 MDP9M053	Ø 5 à/to Ø 7 5 MDP10M050	Ø 9 à/to Ø 11 9 MDP14M090	Ø 16 à/to Ø 19 16 MDP20M160
Câble admissible / Acceptable cable Ø A Référence - P/N		Ø 7 à/to Ø 8,5 6,8 MDP10M068	Ø 11 à/to Ø 13 11 MDP14M110	Ø 19 à/to Ø 23 19 MDP20M190
Câble admissible / Acceptable cable Ø A Référence - P/N		Ø 8,5 à/to Ø 10 8,5 MDP10M085	Ø 13 à/to Ø 15 13 MDP14M130	Ø 23 à/to Ø 25 22 MDP20M220
Câble admissible / Acceptable cable Ø A Référence - P/N		Ø 10 à/to Ø 13 10 MDP10M100	Ø 15 à/to Ø 16 15 MDP14M150	Ø 25 à/to Ø 26 25 MDP20M250

# TP series



## Références des joints toriques Part numbers for O'rings

**Embases REC-RER**  
*REC-RER receptacle*

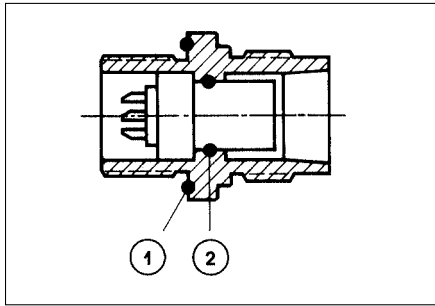

**Fiche FED**  
*FED plug*

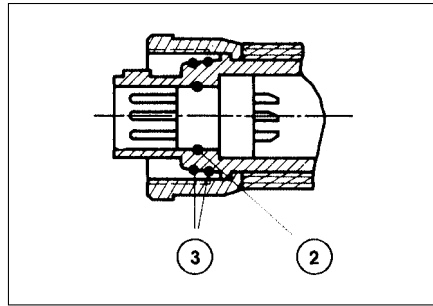

**Prolongateur PCE**  
*PCE cable connecting plug*

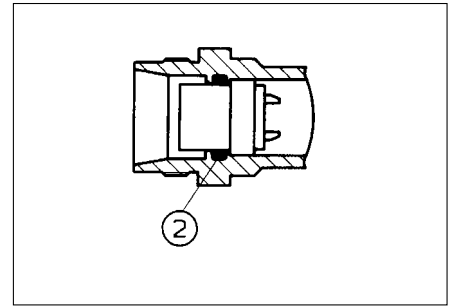

**Traversées TEC-TER**  
*TEC-TER bulkhead*

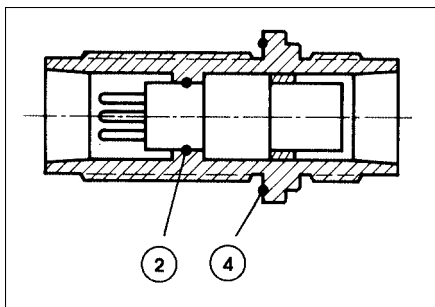

**Bouchon BER**  
*BER cap*

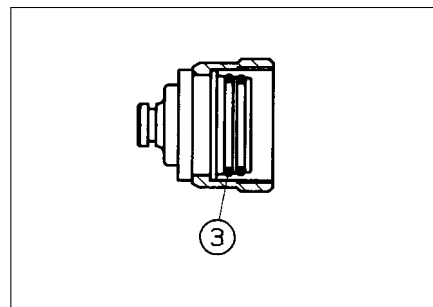

**Prolongateur RECSC**  
*RECSC square flange in-line receptacle*

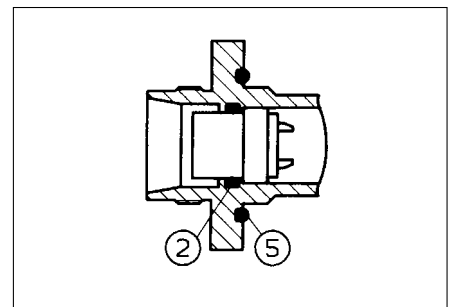

Taille de boîtier / Shell size	8TP	10TP	14TP	20TP
<b>1</b> Sur panneau / On panel Dimension Référence - P/N	Ø 15,1 x 1,6 09-01	Ø 18,77 x 1,78 10-01	Ø 26 x 2,5 14-01	Ø 37,77 x 2,62 20-01
<b>2</b> Sur isolant / On insulator Dimension Référence - P/N	Ø 8,1 x 1,6 09-02	Ø 8,73 x 1,78 10-02	Ø 15,6 x 1,78 14-02	Ø 24 x 2 20-02
<b>3</b> Sur cône / On taper seat Dimension Référence - P/N	Ø 9,1 x 1,6 09-03	Ø 12,42 x 1,78 10-03	Ø 20,35 x 1,78 14-03	Ø 30 x 2 20-03
<b>4</b> Sur panneau / On panel Dimension Référence - P/N	Ø 18,1 x 1,6 09-04	Ø 21,95 x 1,78 10-04	Ø 29,82 x 2,62 14-04	Ø 42,52 x 2,62 20-04
<b>5</b> Sur panneau / On panel Dimension Référence - P/N	Ø 18,77 x 1,78 10-01	Ø 24 x 2 20-02	Ø 31,42 x 2,62 14-05	Ø 42,52 x 2,62 20-04

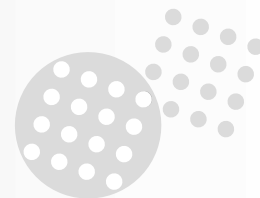

## Références des outillages Tool part numbers

### Outil pour câblage des fiches Plug wiring tool

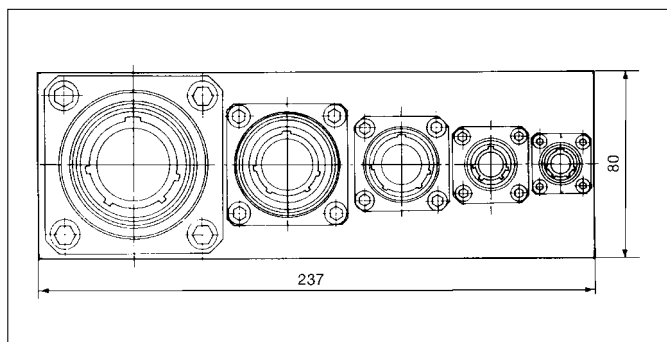

Cet outillage est utilisé pour maintenir correctement les fiches lors de l'opération finale de câblage : serrage de la douille de serrage.

Réf : OUT-321

*This tool is used to have the plugs secured while performing the wiring operation, i.e.: tightening the stacked components in backshell.*

P/N: OUT-321

### Pince à sertir Crimping plier

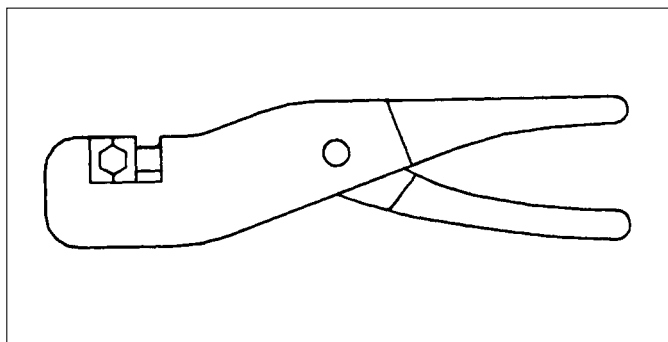

Utilisée pour sertir le contact coaxial des accessoires serre-câbles, références JA et JB, taille 14TP

Pince à sertir : M22520/5-01, matrice M22520/5-27

*Use to crimp coax contact clamping cable accessories, referenced JA and JB, size 14TP.*

Crimping plier : M22520/5-01, fixture M22520/5-27

### Outil de montage des contacts Contact assembling tool

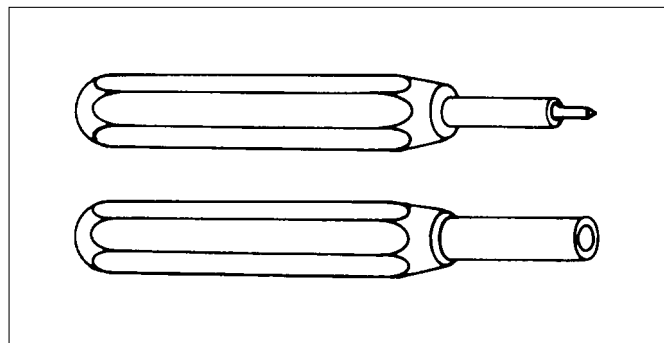

Les contacts démontables sont tenus dans l'isolant par un écrou qui peut être vissé ou dévissé par les outils ci-dessus.

*The removable contacts are held in the insulator by a special nut, which can be screwed or unscrewed, using the tools hereafter.*

Type de contact Contact type	Référence outil Tool P/N
Taille 6 mâle Male size 6	OUT.BMV.20M.16MC
Taille 6 femelle Female size 6	OUT.BFV.20M.16MC
Taille 2 mâle Male size 2	OUT.BMV.20M.35MC
Taille 2 femelle Female size 2	OUT.BFV.20M.35MC
10TP triaxial 50Ω - 75Ω 20TP coaxial 50Ω - 75Ω mâle et femelle male and female	OUT.MC.04

# TP series

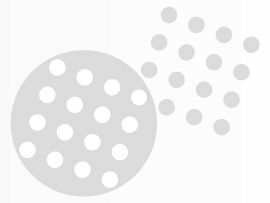

## Références des outillages Tool part numbers

### Pince à mâchoire plastique Plastic jaw plier

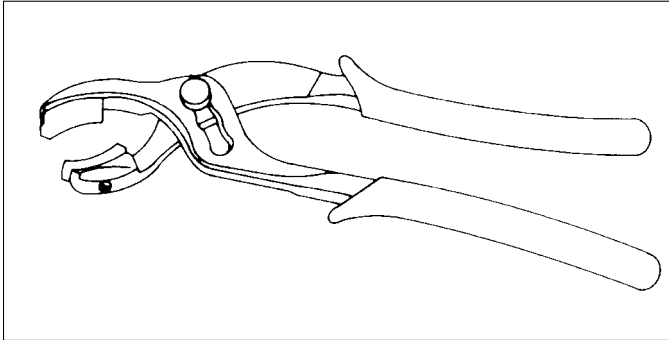

Outil servant à maintenir le corps du serre-câble pendant le serrage de la douille

*This tool is used for holding the cable clamp while tightening the sleeve*

Réf - P/N : 410.01

### Clés de serrage Spanners

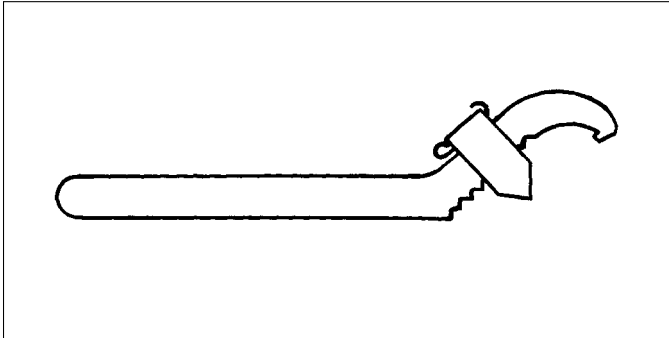

#### Clé à ergot / Pin spanner

Utilisée pour serrer les douilles d'accouplement tailles 8TP-10TP-14TP-20TP

*Used to screw the mating sleeves of shell sizes 8TP, 10TP, 14TP and 20TP*

Réf - P/N : 771.20.42

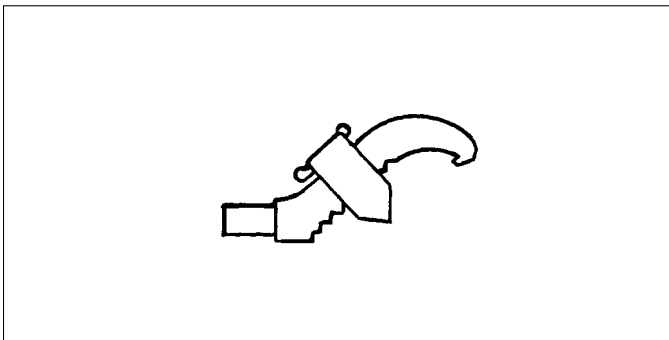

#### Embout à ergot pour clé dynamométrique Pin fixture for torque wrench

Utilisé pour serrer les douilles d'accouplement aux couples (voir tableau B, page 28)  
tailles 8TP-10TP-14TP-20TP

*Used to screw the mating sleeves at specified torques (see table B on page 28), of shell sizes 8TP, 10TP, 14TP and 20TP*

Embout Réf / Pin fixture P/N: **OUT-522/20.42**  
Clé dynamométrique réf / Torque wrench P/N:  
**S 305D ou/ou R 305D**

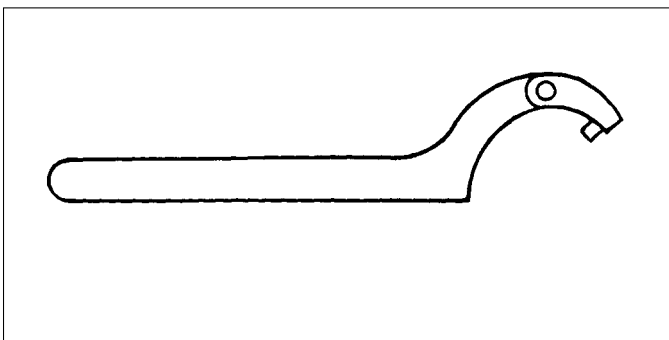

#### Clé à ergot rond / Round pin spanner

Utilisée pour serrer la douille de l'accessoire serre-câble, référence M, taille 14TP

Pour serrer la douille de l'accessoire serre-câble, référence M, taille 20TP, utiliser une clé plate 27 sur plats  
*Used to screw the sleeve of cable clamp accessory, type M, of shell size 14TP*

*To screw the sleeve of cable clamp accessory, type M, of shell size 20TP, use a spanner jaw with 27 clearance.*

Réf - P/N : 776C.20.35.3

# TP series



## Instructions de câblage / Wiring instructions (8TP, 10TP, 14TP, 20TP accessoire serre-câble référence A et U) (8TP, 10TP, 14TP, 20TP cable clamp accessory type A and U)

### 1. Préparation du câble

#### Contrôle

- Contrôler l'aspect du câble : celui-ci doit être parfaitement lisse, rond et sans blessure.
- Vérifier : le diamètre interne du presse-étoupe doit être inférieur à celui de la gaine extérieure.

#### Assemblage des pièces sur le câble

- Nettoyer à l'alcool et enfiler successivement sur le câble (voir figure 1) :
  - le manchon de protection (1) préalablement talqué
  - la douille de serrage (2)
  - le presseur (3)
  - le joint de presse-étoupe (4)
  - la douille de serrage (5)
  - la pince serre-câble (6).

### 1. Cable preparation

#### Inspection

- Check the cable visually. The cable must be smooth, round and free of damages.
- Check: the packing washer inner diameter shall be smaller than the outer sheath's diameter.

#### Assembling the accessories on the cable

- Clean the cable with alcohol and successively slide the following accessories onto the cable (see figure 1) :
  - protection boot (1) : previously treated internally with talcum powder
  - tightening sleeve (2)
  - retainer (3)
  - packing washer (4)
  - clamping sleeve (5)
  - cable clamp (6).

Figure 1

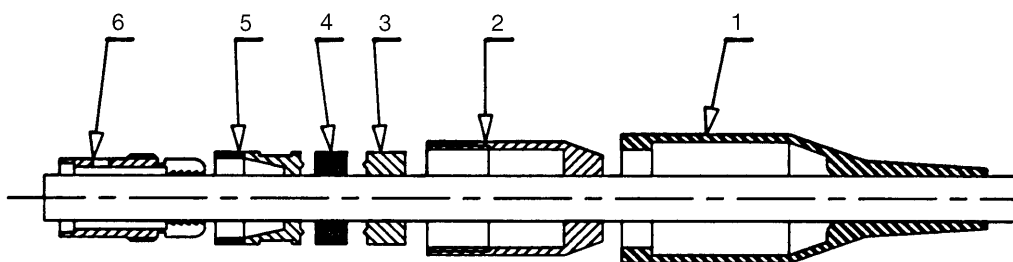

### 2. Câblage

- Dénuder le câble suivant la fig. page 13, accessoire A et U.
- Passer sur chaque fil un manchon thermorétractable : voir fig. 2.
- Souder les conducteurs dans les broches de l'isolant (commencer par les broches centrales) en s'assurant de la propreté de la soudure (nettoyer à l'alcool si nécessaire).
- Mettre en place les manchons thermorétractables en butée sur l'isolant et rétracter.

#### Avec reprise de tresse de masse, accessoire référence U

- Rabattre les brins de la tresse de masse sur la gaine extérieure du câble et la maintenir à l'aide d'un ruban adhésif (voir fig. 2).

### 2. Wiring

- Strip conductors as shown on fig. of page 13, accessory A and U
- Fit a heat shrinking sleeve over each wire: see fig. 2.
- Solder the conductors into contact bucket, starting with the central pin then fanning out toward the periphery. Make sure the wires and especially the copper cores are well cleaned (use alcohol if necessary).
- Slide heat shrinking sleeves, pushed fully against the insulator, and heat them.

#### With ground braid connection, accessory U

- Put down braid strands over cable external sheath and hold it with adhesive tape (see fig. 2).

Figure 2

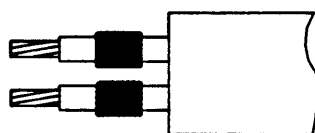

Ruban adhésif / adhesive tape

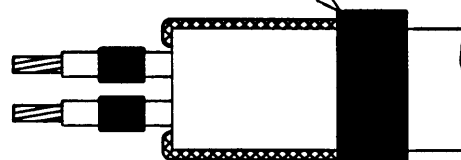

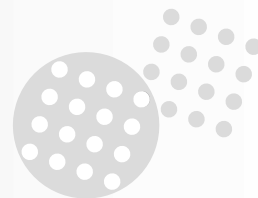

### 3. Montage du connecteur

- Rapprocher la pince (6) jusqu'à son emboîtement sur l'isolant en faisant coïncider les détrompeurs.

#### Avec reprise de tresse de masse, accessoire référence U

- Retirer le ruban adhésif de la tresse de masse, couper à longueur des brins de la tresse de masse (voir figure 3).
- Visser la douille de serrage (5) avec une clé dynamométrique équipée d'un embout adapté (tableau A) au couple défini par le tableau B.
- Maintenir la pince (6) avec une pince à mâchoire plastique (réf. : 410.01) sur le moletage prévu à cet effet.

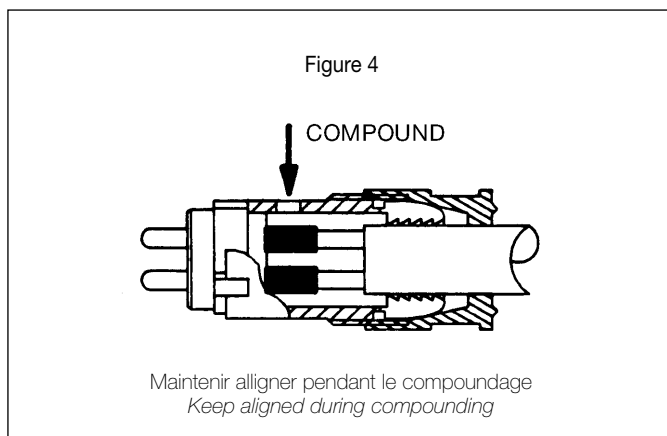
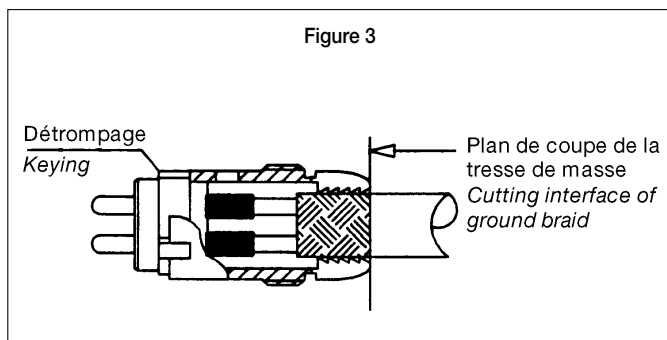

### 4. Compoundage de la chambre de câblage

Cette opération est facultative.

- Utiliser l'une des résines proposées en page 29.
- Mélanger soigneusement les composants suivant les prescriptions du fournisseur.
- Injecter la résine avec une seringue par l'orifice de compoundage de la chambre de câblage (voir figure 4).
- Laisser polymériser 24 h à 20°C (ou plus suivant notice du fournisseur).

### 3. Connector assembly

- Bring cable clamp (6) close to its position on insulator by aligning the locating keys into counterpart keyways.

#### With ground braid connection, accessory U

- Withdraw scotch tape from ground braid, cut strands at appropriate length (see figure 3).
- Screw clamping sleeve (5) onto cable clamp (6) then use a torque wrench equipped with a special tip (see table A) and tighten at specified torque as defined in table B.
- Hold cable clamp (6) with a plastic jaw plier (P/N 410.01) where the milling pattern is provided.

Tableau A / Table A

Taille de clé/embout Torque wrench size/tip	Taille de boîtier / Shell size			
	8TP	10TP	14TP	20TP
Douille de serrage (5) Clamping sleeve	11	13	18	28
Douille de serrage (2) Tightening sleeve	12	16	20	32

Tableau B / Table B

Couple (mdaN) Torque (mdaN)	Taille de boîtier / Shell size			
	8TP	10TP	14TP	20TP
Douille de serrage (5) Tightening sleeve	0,4 à/to 0,6	0,4 à/to 0,6	0,4 à/to 0,6	1 à/to 2
Douille de serrage (2) Tightening sleeve *	0,5 à/to 2,5	1 à/to 3,5	1,5 à/to 4	2 à/to 7
Ecrou d'embase ronde Round receptacle nut	1,2 à/to 1,5	1,7 à/to 2	3,1 à/to 3,5	6 à/to 6,3
Verrou de fiche/ Bouchon de fiche Plug lock / Plug cap	0,8	0,9 à/to 1,1	1,9 à/to 2,2	4,1 à/to 4,4
Bouchon d'embase Receptacle cap	0,9 à/to 1	1,2 à/to 1,5	2,5 à/to 3	3,5 à/to 4

\* Depend de la constitution du câble / Depends on the cable construction

### 4. Wiring Chamber Compounding

This operation is only optional.

- Use any of the resins proposed on page 29.
- Mix the compounds carefully, as specified by the supplier.
- Use a syringe to inject the resin through the compounding hole provided in the wiring chamber (see figure 4).
- Cure for 24 h at 20°C (or more, depending on the supplier's instructions).

# TP series

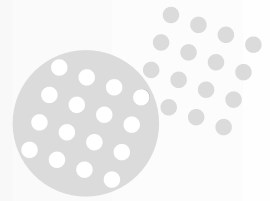

## 5. Assemblage final

- Graisser légèrement le joint intérieur du corps de fiche ainsi que la portée du joint sur le bloc isolant.
- Introduire l'ensemble bloc isolant/pince dans le corps de fiche : **ATTENTION à bien faire coïncider les détrompeurs !**
- Amener en contact le joint de presse-étoupe (4) avec la douille de serrage (5).
- Amener en contact le presseur (3) avec le joint de presse-étoupe (4).

**ATTENTION : le presseur doit dépasser de 2/3 de sa hauteur au minimum par rapport au corps de fiche.**

- Graisser légèrement le filetage de la douille de serrage (2).
- Visser la douille (2) avec une clé dynamométrique équipée d'un embout adapté (tableau A) au couple défini par le tableau B. Pendant cette opération la fiche sera verrouillée sur une embase fixe correspondante (réf. : OUT-321).
- Monter le manchon de protection sur la fiche (en utilisant de l'alcool ou de l'huile).

## Références des notices de câblages

- Accessoire serre-câble référence K : NCA 140 A 400
- Accessoire serre-câble référence M : NCA 140 A 500
- Accessoire serre-câble référence JA-JB : NCA 143 A 400
- Arrangements avec contacts taille 6 ou taille 2 : NCA 140 A 600
- Arrangements 10 TP référence TX-50 ou TX-75 et 20 TP référence 4C-50 ou 4C-75 : NCA 140 A 700
- Arrangement 20 TP référence 04-HT : NCA 144 A 100

## 5. Final Assembly

- Apply a thin coat of silicone grease on the inner o'ring of the plug body as well as its seal seat on the insulator block.
- Engage the insulator block/cable clamp assembly into the plug body: **WARNING! Make sure the locating keys are lined up !**
- Abut the packing washer (4) against the clamping sleeve (5).
- Abut the metal retainer (3) against the packing washer (4).

**WARNING ! the retainer shall protude a minimum of two thirds of its thickness beyond connector plug shell.**

- Slightly grease the thread inside the tightening sleeve (2).
- Screw the tightening sleeve (2) with a torque wrench fitted with a special tip (Table A) then a torque as defined in Table B. During this operation, the plug shall be locked onto a corresponding fixed receptacle (P/N OUT-321).
- Install the protection boot on the plug (use alcohol or oil).

## WIRING MANUALS P/INs

- Cable fitting accessory K : NCA 140 A 400
- Cable fitting accessory M : NCA 140 A 500
- Cable fitting accessory JA,JB : NCA 143 A 400
- Arrangements with size 6/size 2 contacts : NCA 140 A 600
- Arrangements 10TP, TX-50 or TX-75 and 20TP, 4C-50 or 4C-75 : NCA 140 A 700
- Arrangement 20TP, 04-HT : NCA 144 A 100

## Références des résines de compoundage de la chambre de câblage Resins references to be used for coumpounding the wiring chamber

- **ECCOBOND 45** : résine époxy / epoxy resin  
GRACE EMERSON et CUMINGS  
205, avenue Georges Clémenceau - 92000 NANTERRE (France)  
Tél : 46 14 78 40 - Fax : 47 25 40 75
- **DAMIVAL** : résine polyuréthane en trois / polyurethane resin in three components  
dureté shore / shore hardness D2 : 50, 85 et/and 90  
GEC ALSTHOM - ZI du vert galant - 15 rue Aristide Briand  
95310 St-OUEN l'AUMONE (France) - Tél : 30 37 40 54 - Fax : 30 37 54 01
- **CAST 65** : résine polyuréthane "démontable" / polyurethane resin "removable"  
BARNIER  
9-11 rue Edouard - 26001 VALENCE (France) - Tél : 75 44 05 00 - Fax : 75 21 24 47