

# Inline filter with filter element according to DIN 24550

**RE 51421/07.11**  
Replaces: 12.10

1/16

**Type 245LEN0040 to 400; 245LE0130, 0150**

Size according to **DIN 24550**: 0040 to 0400  
 Additional sizes: 0130, 0150  
 Nominal pressure 250 bar [3628 psi]  
 Connection up to G 1 1/2; SAE 1 1/2; SAE 24  
 Operating temperature -10 °C to 100 °C [14 °F to 212 °F]



245LEN\_d

## Table of contents

Content	Page
Features	1
Ordering code	2
Standard types	3
Ordering code:	
Electronic switching element for maintenance indicator	4
Mating connectors according to IEC 60947-5-2	4
Symbols	5
Function, section	6
Technical data	7, 8
Characteristic curves	9...11
Unit dimensions	12
Maintenance indicator	13
Spare parts	14
Installation, commissioning maintenance	15
Quality and standardization	16

## Features

Inline filters are used in hydraulic systems for separating solid materials from the hydraulic fluids and lubricating oils. They are intended for installation into pipelines.

They distinguish themselves by the following:

- Special highly efficient filter media
- Adsorption of very fine particles across a broad pressure differential range
- High dirt holding capacity thanks to large specific filter area
- Good chemical resistance of the filter elements
- High collapse resistance of the filter elements (e.g. in case of cold start)
- Filter ratings of 3 µm to 100 µm
- By default equipped with mechanical optical maintenance indicator with memory function
- Flow-optimized design due to 3D computer-supported design

### Ordering code

of the filter

245	LE	N	-	00	V5,0	-
-----	----	---	---	----	------	---

<b>Pressure</b> 250 bar [3628 psi] = 245	
<b>Inline filter</b> simple = LE	
<b>Filter element</b> according to DIN 24550 = N	
<b>Size</b> LEN... = 0040 0063 0100 0160 0250 0400 LE... = 0130 0150	
<b>Filter rating in µm</b> <b>nominal</b> Stainless steel wire mesh, cleanable G10, G25, G40, G100 = G... <b>absolute (ISO 16889)</b> Micro glass, not cleanable H3XL, H6XL, H10XL, H20XL = H...XL	
<b>Pressure differential</b> max. admissible pressure differential of the filter element 30 bar [435 psi], with bypass valve 7 bar [102 psi] = A 330 bar [4786 psi], without bypass valve = B	
<b>Element design</b> Standard adhesive T = 100 °C [212 °F] = 0... Standard material = ...0	

	Frame size	Connection				Seal
		0040	0063-0100	0130-0150	0160-0400	
<b>R2 =</b>	G1/2	•	x			Pipe thread according to ISO 228
<b>R3 =</b>	G3/4	x	x			
<b>R4 =</b>	G1	x	•	x		
<b>R5 =</b>	G1 1/4			•	x	
<b>R6 =</b>	G1 1/2			x	•	SAE flange 6000 psi
<b>S6 =</b>	SAE 1 1/2"				x	
<b>U3 =</b>	SAE 10	x				Pipe thread according to SAE J1926
<b>U4 =</b>	SAE 12		x			
<b>U5 =</b>	SAE 20			x		
<b>U6 =</b>	SAE 24				x	

• = Standard connection  
x = Additional connection possibility

<b>M =</b>	NBR seal
<b>V =</b>	FKM seal

**Maintenance indicator**

**V5.0 =** Maintenance indicator, optical specify switching pressure 5.0 bar [72.5 psi]

**Order example:**  
245LEN0100-H10XLA00-V5,0-M-R4

Further models (filter materials, connections,...) are available at request.

of the filter element

2.		-	-	0	
----	--	---	---	---	--

<b>Filter element</b> Design = 2.	
<b>Size</b> LEN... = 0040 0063 0100 0160 0250 0400 LE... = 0130 0150	
<b>Filter rating in µm</b> <b>nominal</b> Stainless steel wire mesh, cleanable G10, G25, G40, G100 = G... <b>absolute (ISO 16889)</b> Micro glass, not cleanable H3XL, H6XL, H10XL, H20XL = H...XL	

<b>M =</b>	NBR seal
<b>V =</b>	FKM seal
<b>0 =</b>	Bypass valve at filter element always 0
<b>A00 =</b>	Pressure differential max. admissible pressure differential of the filter element 30 bar [435 psi]
<b>B00 =</b>	330 bar [4786 psi]

**Order example:**  
2.0100 H3XL-A00-0-M

## Standard types

245LE(N) standard types, NBR seal, flow information for  $v = 30 \text{ mm}^2/\text{s}$  [150 SUS]

### Inline filter with bypass, filtration rating 3 $\mu\text{m}$

Type	Flow in l/min [gpm] with $\Delta p = 1 \text{ bar}$ [14.5 psi] <sup>1)</sup>	Material no. Filter				Material no. Replacement element
		..R2	R928030024	..U3	R928030216	
245LEN0040-H3XLA00-V5,0-M-..	23 [5.1]	..R2	R928030024	..U3	R928030216	R928006645
245LEN0063-H3XLA00-V5,0-M-..	30 [6.6]	..R4	R928030025	..U4	R928030217	R928006699
245LEN0100-H3XLA00-V5,0-M-..	44 [9.7]	..R4	R928030026	..U4	R928030218	R928006753
245LE0130-H3XLA00-V5,0-M-..	74 [16.3]	..R5	R928030027	..U5	R928030219	R928022274
245LE0150-H3XLA00-V5,0-M-..	89 [19.6]	..R5	R928030028	..U5	R928030220	R928022283
245LEN0160-H3XLA00-V5,0-M-..	132 [29.0]	..R6	R928030029	..U6	R928030221	R928006807
245LEN0250-H3XLA00-V5,0-M-..	190 [41.8]	..R6	R928030030	..U6	R928030222	R928006861
245LEN0400-H3XLA00-V5,0-M-..	250 [55.0]	..R6	R928030031	..U6	R928030223	R928006915

### Inline filter with bypass, filtration rating 6 $\mu\text{m}$

Type	Flow in l/min [gpm] with $\Delta p = 1 \text{ bar}$ [14.5 psi] <sup>1)</sup>	Material no. Filter				Material no. Replacement element
		..R2	R928030280	..U3	R928030472	
245LEN0040-H6XLA00-V5,0-M-..	30 [6.6]	..R2	R928030280	..U3	R928030472	R928006646
245LEN0063-H6XLA00-V5,0-M-..	52 [11.4]	..R4	R928030281	..U4	R928030473	R928006700
245LEN0100-H6XLA00-V5,0-M-..	61 [13.4]	..R4	R928030282	..U4	R928030474	R928006754
245LE0130-H6XLA00-V5,0-M-..	101 [22.2]	..R5	R928030283	..U5	R928030475	R928022275
245LE0150-H6XLA00-V5,0-M-..	120 [26.4]	..R5	R928030284	..U5	R928030476	R928022284
245LEN0160-H6XLA00-V5,0-M-..	172 [37.8]	..R6	R928030285	..U6	R928030477	R928006808
245LEN0250-H6XLA00-V5,0-M-..	226 [49.7]	..R6	R928030286	..U6	R928030478	R928006862
245LEN0400-H6XLA00-V5,0-M-..	276 [60.7]	..R6	R928030287	..U6	R928030479	R928006916

### Inline filter with bypass, filtration rating 10 $\mu\text{m}$

Type	Flow in l/min [gpm] with $\Delta p = 1 \text{ bar}$ [14.5 psi] <sup>1)</sup>	Material no. Filter				Material no. Replacement element
		..R2	R928030536	..U3	R928030728	
245LEN0040-H10XLA00-V5,0-M-..	36 [7.9]	..R2	R928030536	..U3	R928030728	R928006647
245LEN0063-H10XLA00-V5,0-M-..	69 [15.2]	..R4	R928030537	..U4	R928030729	R928006701
245LEN0100-H10XLA00-V5,0-M-..	75 [16.5]	..R4	R928030538	..U4	R928030730	R928006755
245LE0130-H10XLA00-V5,0-M-..	127 [27.9]	..R5	R928030539	..U5	R928030731	R928022276
245LE0150-H10XLA00-V5,0-M-..	150 [33.0]	..R5	R928030540	..U5	R928030732	R928022285
245LEN0160-H10XLA00-V5,0-M-..	210 [46.2]	..R6	R928030541	..U6	R928030733	R928006809
245LEN0250-H10XLA00-V5,0-M-..	260 [57.2]	..R6	R928030542	..U6	R928030734	R928006863
245LEN0400-H10XLA00-V5,0-M-..	300 [66.0]	..R6	R928030543	..U6	R928030735	R928006917

<sup>1)</sup> Measured pressure differential across filter and measuring equipment according to ISO 3968. The measured pressure differential at the maintenance indicator is lower.

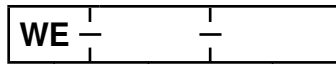
**Ordering code:** Electronic switching element for maintenance indicator**Maintenance indicator**

Electronic switching element

= WE

**Type of signal**

1 switching point

= 1SP

2 switching points, 3 LED

= 2SP

2 switching points, 3 LED and signal suppression at 30 °C [86 °F]

= 2SPSU

**Connector**

M12x1 = Round plug-in connection M12x1, 4-pin

EN 175301-803 = Rectangular plug-in connection, 2-pin design A according to EN-175301-803

**Material numbers of the electronic switching elements**

Material no.	Type	Signal	Switching points	Connector	LED
R928028409	WE-1SP-M12x1	Changeover	1	M12x1	No
R928028410	WE-2SP-M12x1	Normally open (at 75 %) / normally closed contact (at 100 %)	2		3 pieces
R928028411	WE-2SPSU-M12x1				
R928036318	WE-1SP-EN175301-803	Normally closed contact	1	EN 175301-803	No

**Order example:** Inline filter with mechanical optical maintenance indicator for  $p_{nom.} = 250 \text{ bar}$  [3628 psi] with bypass valve, size 0100, with filter element 10  $\mu\text{m}$  and electronic switching element M12x1 with 1 switching point for hydraulic fluid mineral oil HLP according to DIN 51524.

**Filter:** 245LEN0100-H10XLA00-V5,0-M-R4

**Material no. R928030538**

**Maintenance indicator:** WE-1SP-M12x1

**Material no. R928028409**

**Mating connectors according to IEC 60947-5-2 (dimensions in mm [inch])**

for electronic switching element with round plug-in connection M12x1

**Mating connector for K24 4-pin, M12x1 with screw connection, cable gland Pg9.**

**Material no. R900031155**

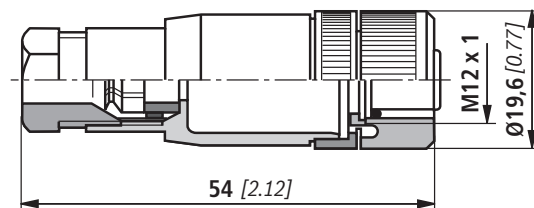

**Mating connector for K24-3m 4-pin, M12x1 with potted-in PVC cable, 3 m long.**

**Line cross-section:** 4 x 0.34 mm<sup>2</sup>

**Core marking:**

1	Brown
2	White
3	Blue
4	Black

**Material no. R900064381**

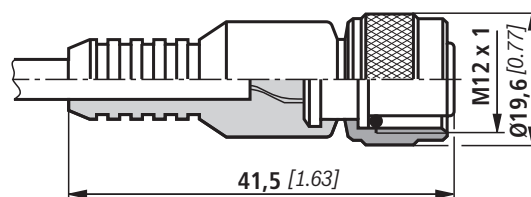

For more round plug-in connections, see data sheet 08006.

# Symbols

**Inline filter with bypass and mechanical indicator**

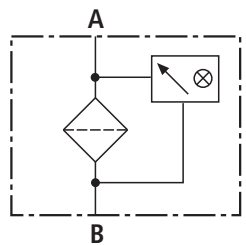
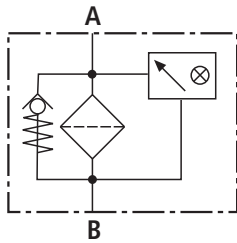

**Inline filter without bypass and mechanical indicator**

**Electronic switching element for maintenance indicator**

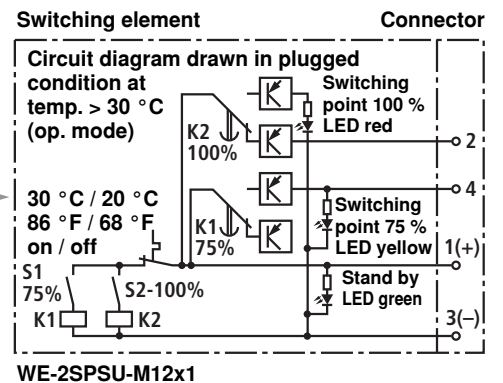
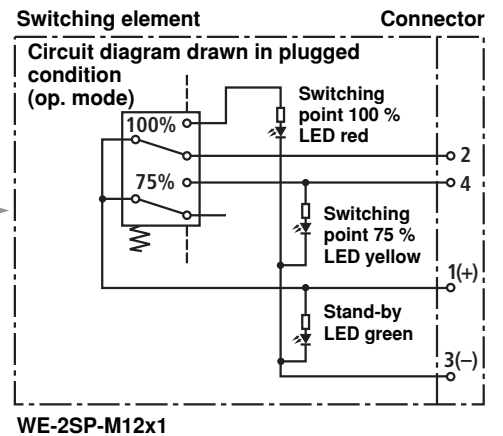
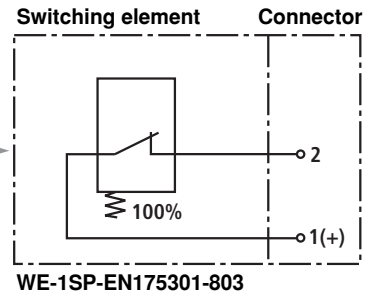
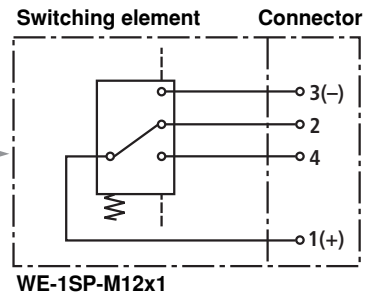

## Function, section

The 245LE(N) inline filters are suitable for direct installation into pressure lines. They are mostly installed upstream open-loop or closed-loop control units to be protected.

They basically consist of filter head (1), a screwable filter bowl (2), filter element (3) as well as mechanical optical maintenance indicator (4). In case of filters with low-pressure-differential-stable filter elements (= code letter pressure differential A), there is also an assembled bypass valve (5).

Via port I, the hydraulic fluid reaches the filter element (3) where it is cleaned. The dirt particles filtered out settle in the filter bowl (2) and in the filter element (3). Via port O, the filtered hydraulic fluid enters the hydraulic circuit.

The filter housing and all connection elements are designed so that pressure peaks - as they may e.g. occur in case of the abrupt opening of large control valves due to the accelerated fluid weight - can be securely absorbed. As of size 0160, the standard equipment comprises an oil drain plug (7).

Basically, the filter is equipped with mechanical optical maintenance indicator (4). The electronic maintenance indicator is connected via the electronic switching element with 1 or 2 switching points (6), which has to be ordered separately. The electronic switching element is attached to the mechanical optical maintenance indicator and held by means of a locking ring.

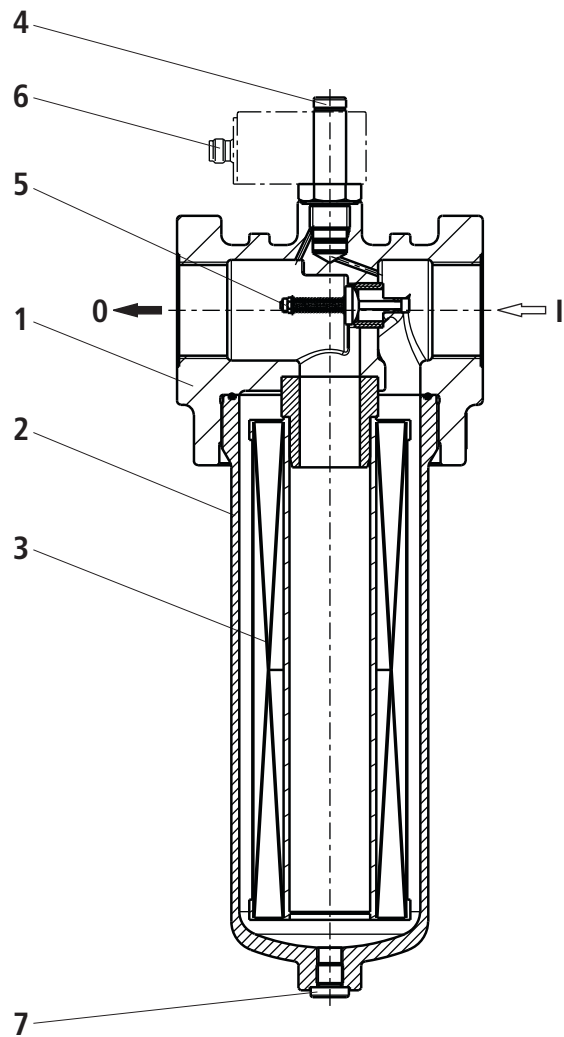

**Technical data** (For applications outside these parameters, please consult us!)**general**

Installation position	vertical				
Ambient temperature range	°C [°F]	-30 to +100 [-22 to +212]			
Weight	Size	<b>0040</b>	<b>0063</b>	<b>0100</b>	<b>0130</b>
	kg [lbs]	3.2 [7.10]	3.8 [8.40]	4.2 [9.30]	6.95 [15.30]
Weight	Size	<b>0150</b>	<b>0160</b>	<b>0250</b>	<b>0400</b>
	kg [lbs]	7.25 [16]	11.5 [25.40]	12.2 [26.90]	13.8 [30.40]
Material	Filter head	GGG			
	Filter bowl	Steel			
	Optical maintenance indicator	Brass			
	Electronic switching element	Plastic PA6			

**hydraulic**

Maximum operating pressure	bar [psi]	250 [3628]
Hydraulic fluid temperature range	°C [°F]	-10 to +100 [+14 to +212]
Fatigue strength according to ISO 10771	Load cycles	> 10 <sup>6</sup> with max. operating pressure
Cracking pressure of the bypass valve	bar [psi]	7 ± 0.5 [100 ± 7]
Type of pressure measurement of the maintenance indicator	Pressure differential	
Response pressure of the maintenance indicator	bar [psi]	5 ± 0.5 [72 ± 7]

**electrical** (electronic switching element)

Electrical connection	Round plug-in connection M12x1, 4-pin			Standard connection EN 175301-803	
	Version	1SP-M12x1	2SP-M12x1	2SP-M12x1	1SP-EN175301-803
Contact load, direct voltage	A <sub>max.</sub>	1			
Voltage range	V <sub>max.</sub>	150 (AC/DC)	10-30 (DC)		250 (AC) / 200 (DC)
Max. switching power with resistive load	W	20			70
Switching type	75 % signal	-	Normally open contact		-
	100 % signal	Change-over	Normally closed contact		Normally closed contact
	2SPSU			Signal switching through at 30 °C [86 °F], Return switching at 20 °C [68 °F]	
Display via LEDs in the electronic switching element 2SP...		Stand-by (LED green); 75 % switching point (LED yellow) 100 % switching point (LED red)			
Protection class according to EN 60529		IP 67			IP 65
Ambient temperature range	°C [°F]	-25 to +85 [-13 to +185]			
For direct voltage above 24 V, spark extinguishing is to be provided for protecting the switching contacts.					
Weight	Electronic switching element: - with round plug-in connection M12x1	kg [lbs]	0.1 [0.22]		

**Technical data** (For applications outside these parameters, please consult us!)**Filter element**

<b>Glass fiber paper H..XL</b>			Single-use element on the basis of inorganic fiber
			Filtration ratio according to ISO 16889 up to $\Delta p = 5 \text{ bar [72.5 psi]}$
			Achievable oil cleanliness according to ISO 4406 [SAE-AS 4059]
		H20XL	$\beta_{20}(c) \geq 200$
		H10XL	$\beta_{10}(c) \geq 200$
		H6XL	$\beta_6(c) \geq 200$
		H3XL	$\beta_3(c) \geq 200$
admissible pressure differential	A	bar [psi]	30 [435]
	B	bar [psi]	330 [4785]

**Seal material for hydraulic fluids**

<b>Mineral oil</b>			Ordering code
Mineral oil	HLP	according to DIN 51524	M
<b>Flame-resistant hydraulic fluids</b>			Ordering code
Emulsions	HFA-E	according to DIN 24320	M
Synthetic water solutions	HFA-S	according to DIN 24320	M
Water solutions	HFC	according to VDMA 24317	M
Phosphoric acid esters	HFD-R	according to VDMA 24317	V
Organic esters	HFD-U	according to VDMA 24317	V
<b>Fast biodegradable hydraulic fluid</b>			Ordering code
Triglycerides (rape seed oil)	HETG	according to VDMA 24568	M
Synthetic esters	HEES	according to VDMA 24568	V
Polyglycols	HEPG	according to VDMA 24568	V

**Characteristic curves** (measured with HLP46, according to ISO 3968)

**H3XL**

Specific weight: < 0.9 kg/dm<sup>3</sup>

$\Delta p$ -Q characteristic curves for complete filters recommended  
initial  $\Delta p$  for design = 1 bar [14.5 psi]

A proper filter design is enabled by our computer program  
"BRFilterSelect".

Oil viscosity:  
 — 140 mm<sup>2</sup>/s [649 SUS]  
 - · - 68 mm<sup>2</sup>/s [315 SUS]  
 - - - 30 mm<sup>2</sup>/s [142 SUS]

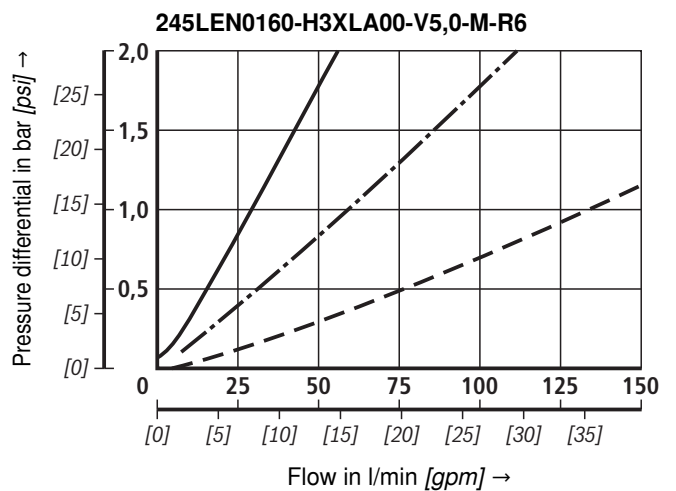
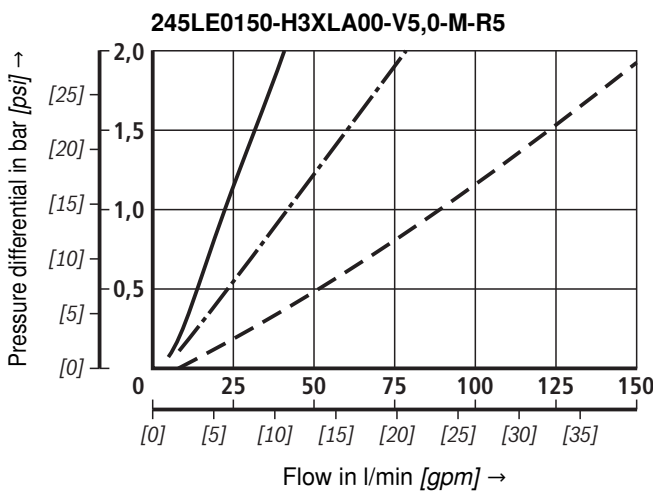
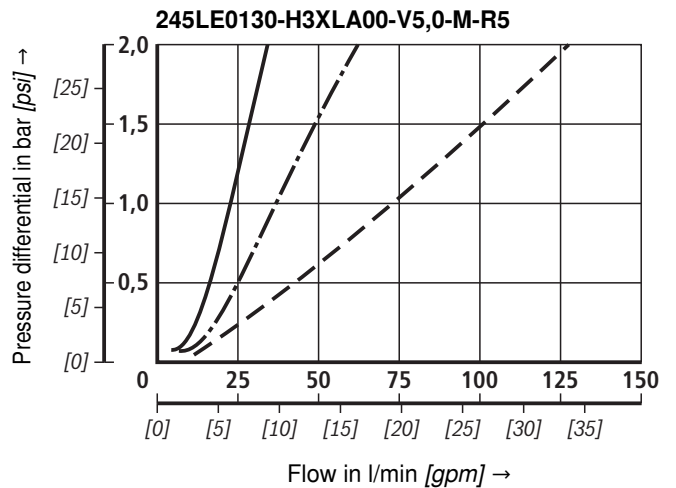
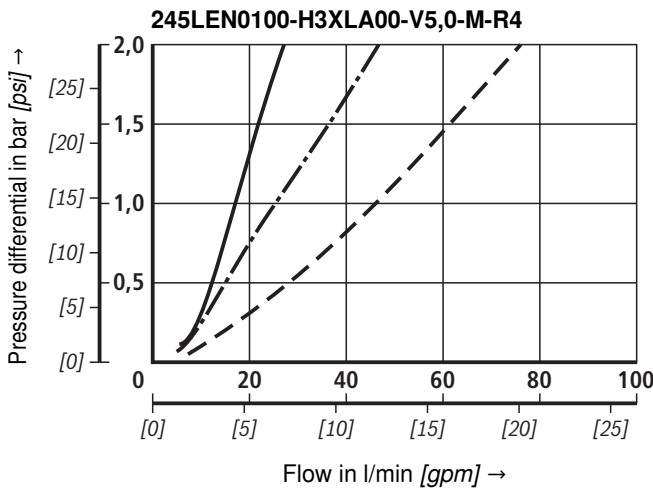
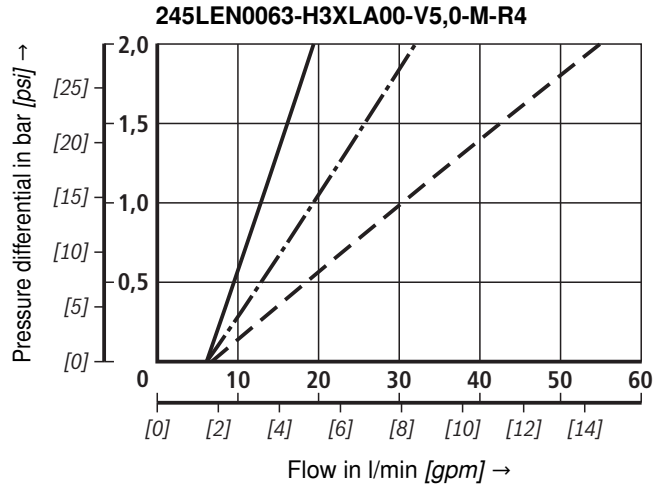
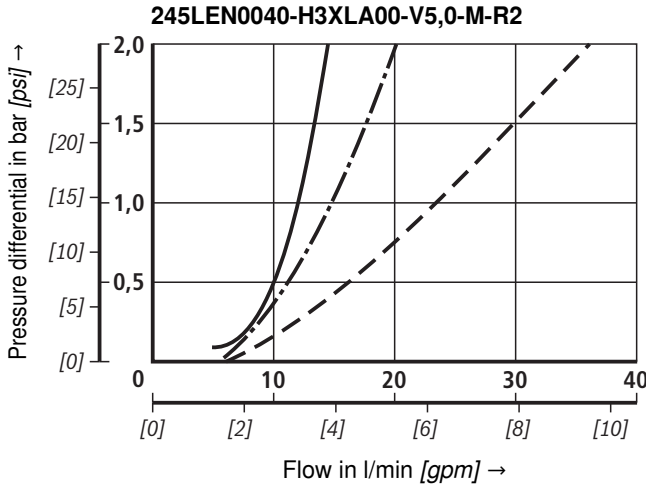

**Characteristic curves** (measured with HLP46, according to ISO 3968)

**H3XL, H10XL**

Specific weight: < 0.9 kg/dm<sup>3</sup>

$\Delta p$ -Q characteristic curves for complete filters recommended  
initial  $\Delta p$  for design = 1 bar [14.5 psi]

A proper filter design is enabled by our computer program  
"BRFilterSelect".

Oil viscosity:   
 — 140 mm<sup>2</sup>/s [649 SUS]   
 - · - 68 mm<sup>2</sup>/s [315 SUS]   
 - - - 30 mm<sup>2</sup>/s [142 SUS]

**H3XL**

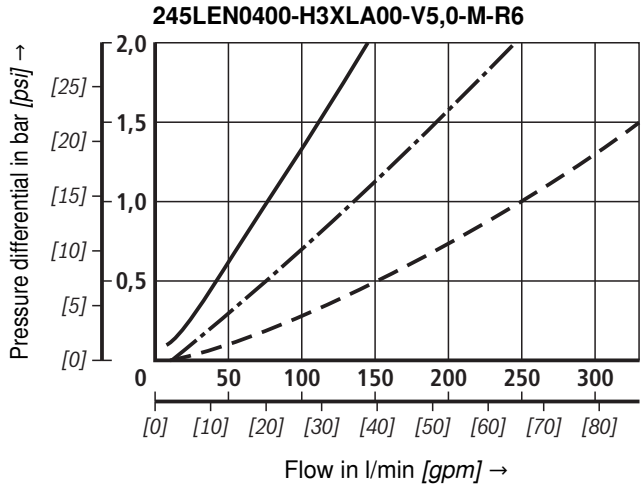
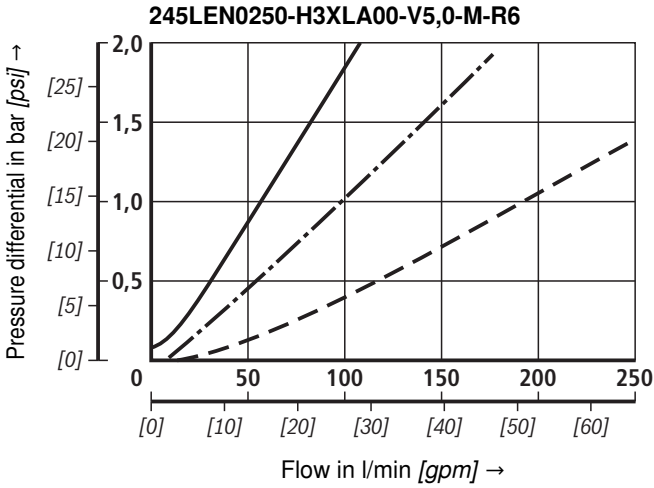

**H10XL**

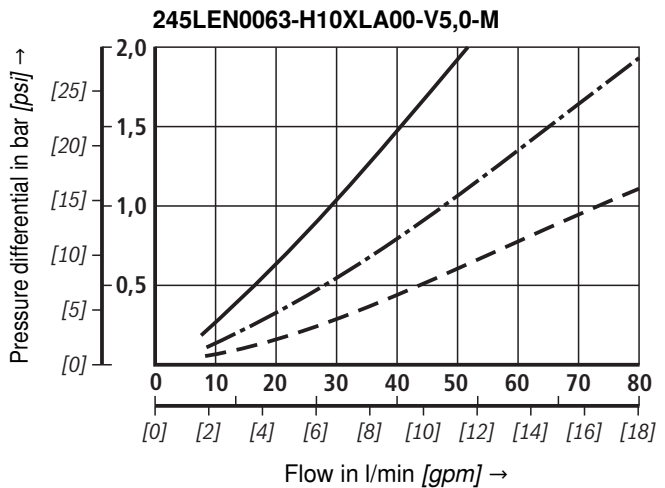
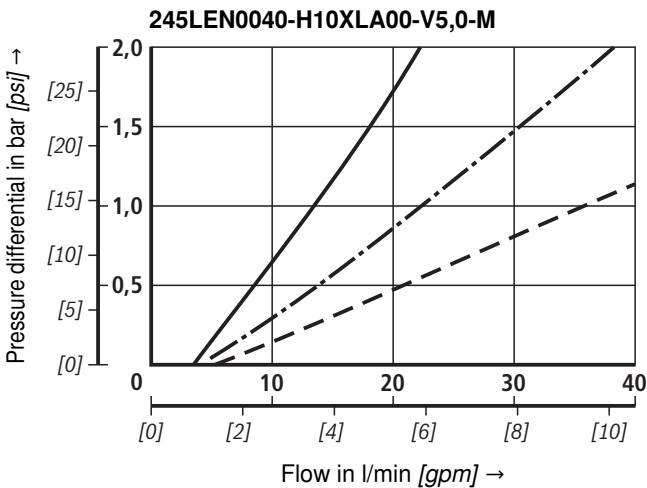

**Characteristic curves** (measured with HLP46, according to ISO 3968)

**H10XL**

Specific weight: < 0.9 kg/dm<sup>3</sup>

$\Delta p$ -Q characteristic curves for complete filters recommended  
initial  $\Delta p$  for design = 1 bar [14.5 psi]

A proper filter design is enabled by our computer program  
"BRFilterSelect".

Oil viscosity:   
 — 140 mm<sup>2</sup>/s [649 SUS]   
 - · - 68 mm<sup>2</sup>/s [315 SUS]   
 - - - 30 mm<sup>2</sup>/s [142 SUS]

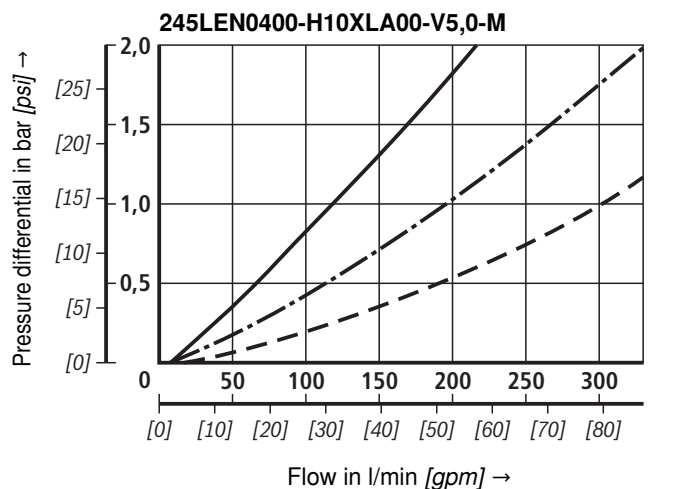
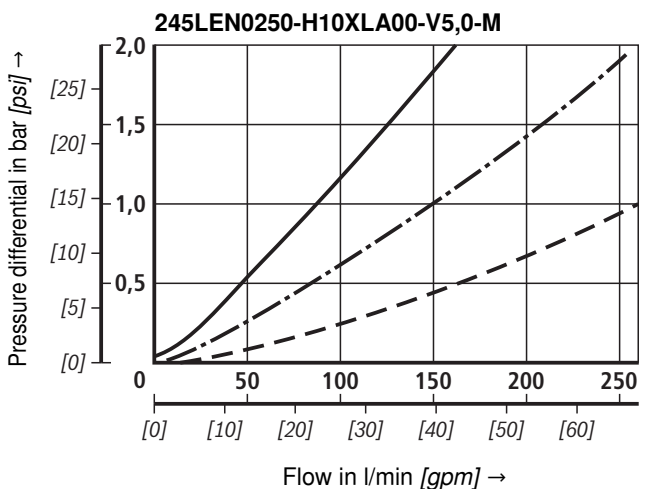
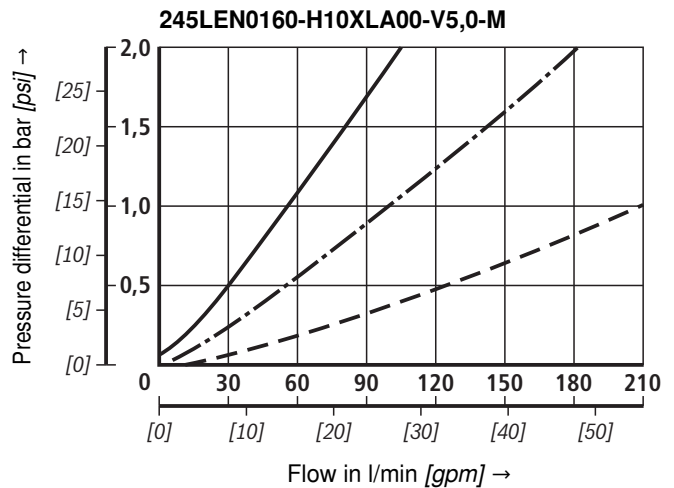
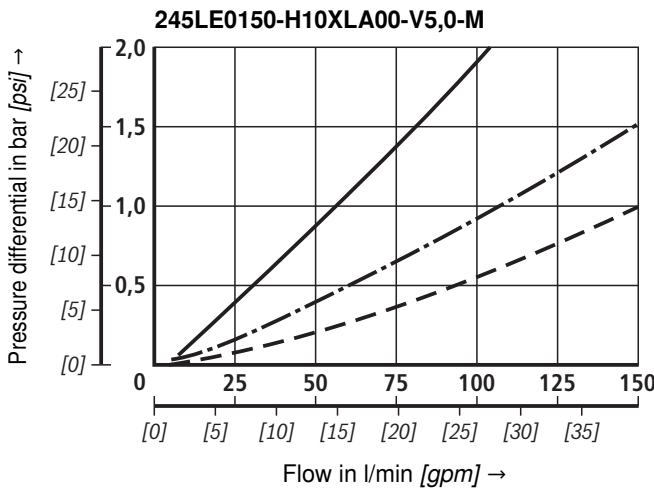
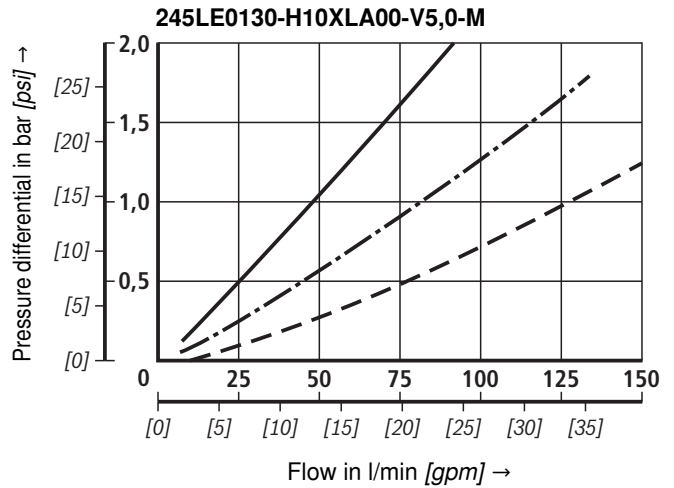
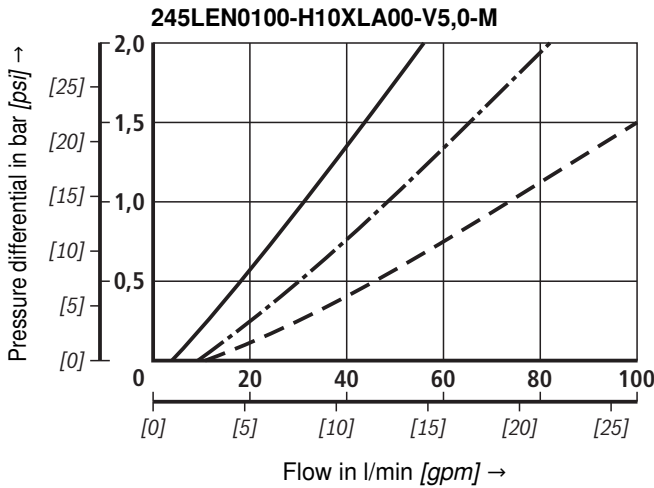

**Unit dimensions NG 0040 to NG 0400 (dimensions in mm [inch])**

Connections  
pipe threads  
UNF thread

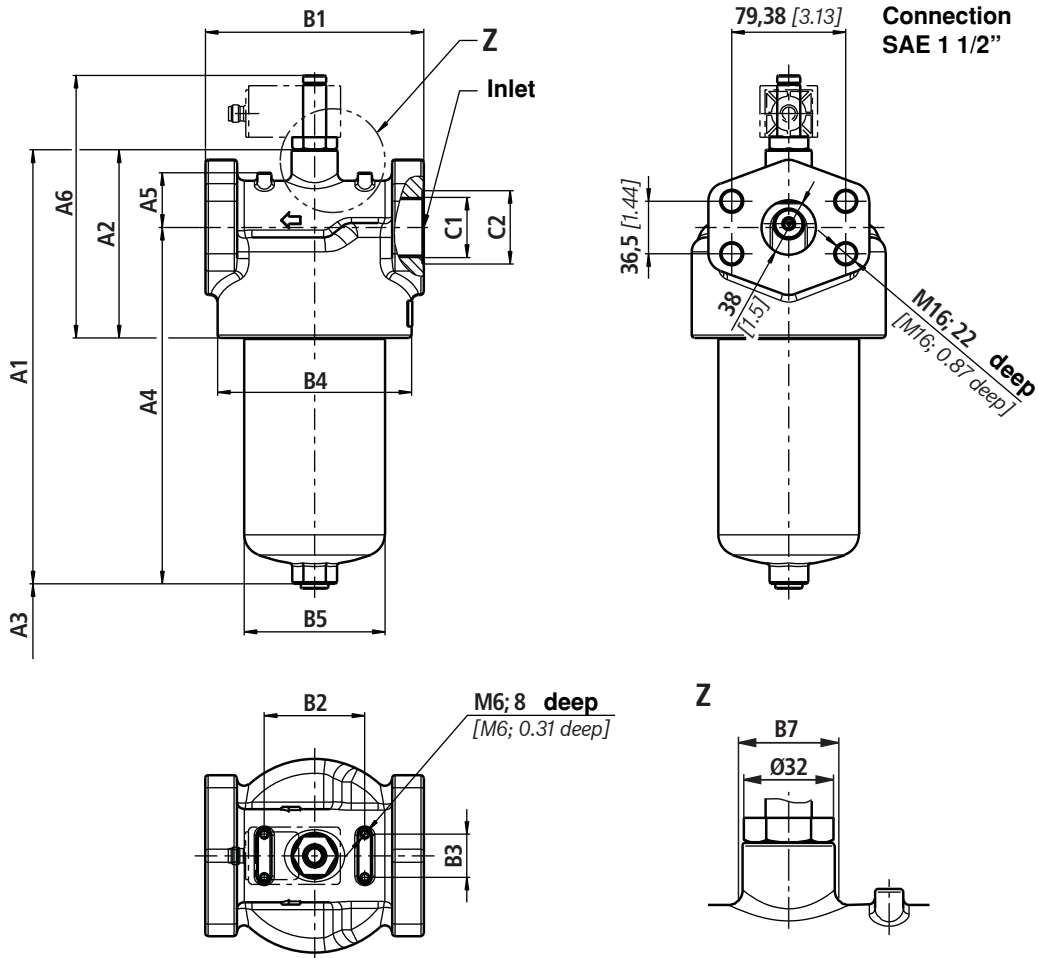

**Filter housing for filter elements in accordance with DIN 24550 and according to BR standard**

Type 245 LE(N)...	Content in l [US gal]	A1	A2	A3 <sup>1)</sup>	A4	A5	A6	B1 <sup>2)</sup>	B2	B3	B4 Ø	B5 Ø	B7 Ø	C1 Standard	U... (SAE J1926)
0040	0.21 [0.06]	200 [7.87]			156 [6.14]									G1/2	SAE 10 7/8-14 UNF-2B
0063	0.38 [0.10]	264 [10.39]	94 [3.70]	120 [4.72]	220 [8.66]	25 [0.98]	146 [5.75]	92 [3.62]	60 [2.36]	25 [0.98]	85 [3.35]	55 [2.17]	34 [1.34]	G1	SAE 12 1 1/16-12 UN-2B
0100	0.53 [0.14]	354 [13.94]			310 [12.20]										
0130	0.76 [0.20]	324 [12.76]	121 [4.76]	140 [5.51]	270 [10.63]		173 [6.81]	122 [4.80]	80 [3.15]		116 [4.57]	77 [3.03]	32 [1.26]	G1 1/4	SAE 20 1 5/8-12 UN-2B
0150	0.96 [0.25]	374 [14.72]			320 [12.60]									G1 1/2	SAE 24 1 7/8-12 UN-2B
0160	1.13 [0.30]	356 [14.02]			302 [11.89]	38 [1.50]				30 [1.18]					
0250	1.6 [0.42]	392 [15.43]	131 [5.16]	120 [4.72]	338 [13.31]		183 [7.20]	152 [5.98]	70 [2.76]		135 [5.31]	98 [3.86]	32 [1.26]		
0400	2.4 [0.63]	542 [21.34]			488 [19.21]										

<sup>1)</sup> Servicing height for filter element replacement

<sup>2)</sup> For SAE flanges dimension B1 is reduced by 4 mm [0.16 inch]

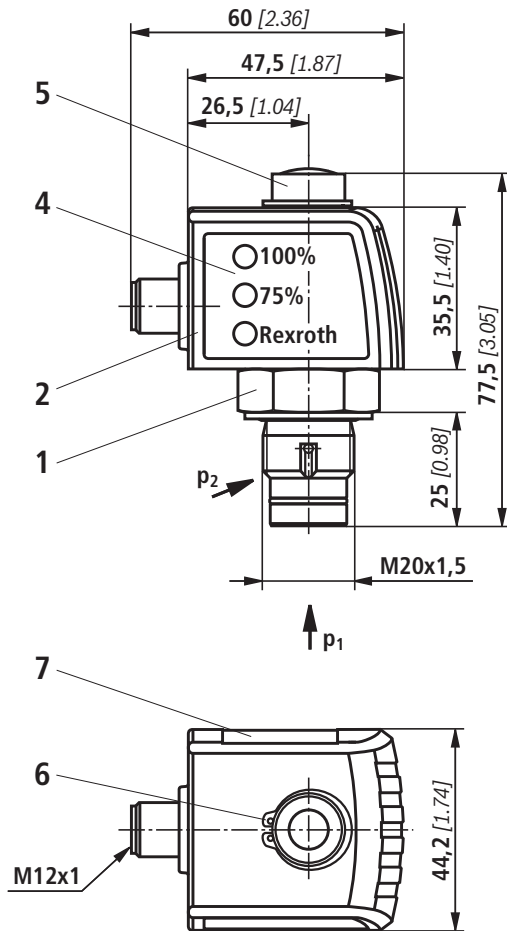
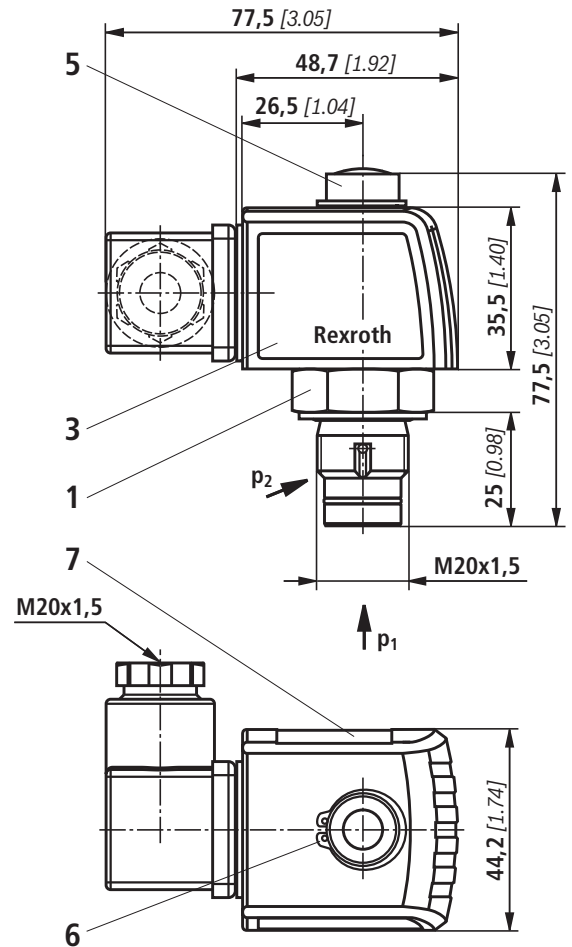
**Maintenance indicator** (dimensions in mm [inch])**Pressure differential indicator with assembled switching element M12x1****Pressure differential indicator with assembled switching element EN-175301-803**

- 1 Mechanical optical maintenance indicator; max. tightening torque  $M_{A \max} = 50 \text{ Nm}$  [36.88 lb-ft]
- 2 Switching element with locking ring for electrical maintenance indicator (rotatable by 360°); round plug-in connection M12x1, 4-pin
- 3 Switching element with locking ring for electrical maintenance indicator (rotatable by 360°); rectangular plug-in connection EN175301-803
- 4 Housing with three LEDs: 24 V =  
Green: Stand-by  
Yellow: Switching point 75 %  
Red: Switching point 100 %
- 5 Optical indicator bistable
- 6 Locking ring DIN 471-16x1,  
**Material no. R900003923**
- 7 Name plate

**Notes:**

Presentation contains mechanical optical maintenance indicator (1) and electronic switching element (2) (3).

Switching elements with increased switching power at request.

## Spare parts

### Mechanical optical maintenance indicator

<b>W</b>	<b>O</b>	<b>D01</b>	<b>160</b>
----------	----------	------------	------------

Maintenance indicator	= W	
Mechanical optical indicator	= O	
<b>Design</b>		
Pressure differential, design 01	= D01	
<b>Switching pressure</b>		
5.0 bar	= 5.0	
2.2 bar	= 2.2	
1.5 bar	= 1.5	

	<b>Max. operating pressure</b>
	D01-1,5; D01-2,2
<b>160 =</b>	160 bar [2321 psi]
	D01-5,0
<b>450 =</b>	450 bar [6527 psi]
	<b>Seal</b>
<b>M =</b>	NBR seal
<b>V =</b>	FKM seal

Mechanical optical maintenance indicator	Material no.
WO-D01-5,0-M-450	R901025313
WO-D01-2,2-M-160	R901025312
WO-D01-1,5-M-160	R928038781

### Seal kit

<b>D</b>	<b>245LE</b>		
----------	--------------	--	--

Seal kit	= D	
Series	= 245LE	
<b>Size</b>		
NG0040-0100	= N0040-0100	
NG0130-0150	= 0130-0150	
NG0160-0400	= N0160-0400	

	<b>Seal</b>
<b>M =</b>	NBR seal
<b>V =</b>	FKM seal

Seal kit	Material no.
D245LEN0040-0100-M	R928028016
D245LE0130-0150-M	R928028214
D245LEN0160-0400-M	R928028017

## Installation, commissioning and maintenance

---

### Installation of the filter

Verify operating overpressure with name plate information. Remove the blanking plugs in the filter inlet and outlet. Screw the filter head (1) to the fastening device, considering flow direction (direction arrows) and servicing height of the element. Make sure that the components are assembled in a stressless form. The housing must be grounded.

The filter must preferably be installed with the filter bowl (2) downward. The maintenance indicator must be arranged in a well visible way.

### Connection of the electronic maintenance indicator

Basically, the filter is equipped with mechanical optical maintenance indicator (4). The electronic maintenance indicator is connected via the switching element (6) with 1 or 2 switching points, which is attached to the mechanical optical maintenance indicator and held by means of the locking ring.

### When must the filter element be exchanged or cleaned respectively?

- After initial start-up of the system, the filter element is to be exchanged.
- Upon start-up in cold condition, the red pushbutton of the optical maintenance indicator (4) may jump out and an electrical signal is output via the switching element. Only push the red pushbutton in again after the operating temperature has been reached. If it jumps out again immediately or if the electrical signal has not gone out at operating temperature, the filter element must be exchanged or cleaned respectively after the end of the shift.
- The filter element should be replaced or cleaned after max. 6 months at the latest.

### Element exchange

- Switch off the system and discharge the filter on the pressure side.
- Screw off the filter bowl (2) by anticlockwise rotation. Clean the filter housing in a suitable medium.
- Remove the filter element (3) from the spigot in the filter head by turning it slightly.
- Check the seal ring in the filter bowl for position and damage. If necessary, these parts are to be renewed.
- Replace filter elements H...XL, clean filter elements G...
- The efficiency of the cleaning process depends on the type of dirt and the amount of the pressure differential before the filter element exchange. If the differential pressure after the filter element exchange exceeds 150 % of the value of a brand-new filter element, the G... element also needs to be replaced.
- Check whether the type designation or material number on the replacement element corresponds to the type designation/material number on the name plate of the filter.
- Install replaced or cleaned filter element on the spigot again by slightly turning it.
- Now screw in the filter bowl to stop (torque 50 Nm <sup>+10 Nm</sup>).

## Quality and standardization

The inline filters for hydraulic applications according to 51448 are pressure holding equipment according to article 1, section 2.1.4 of the pressure equipment directive 97/23/EC (PED). However, on the basis of the exception in article 1, section 3.6 of the PED, hydraulic filters are exempt from the PED if they are not classified higher than category I (guideline 1/19). They do not receive a CE mark.

### Use in explosive areas according to directive 94/9/EC (ATEX)

The inline filters according to 51448 are no equipment or components in the sense of directive 94/9/EC and are not provided with a CE mark.

When using the inline filters according to 51448 in explosive areas, potential equalization has to be ensured.

According to DIN EN 60079-11, the electronic maintenance indicators WE-1SP-M12x1 are simple, electronic operating equipment not having an own voltage source. This simple, electronic operating equipment may - according to DIN EN 60079-14 - in intrinsically safe electrical circuits (EEx ib) be used in systems for device group II, category 2G (zone 1) and category 3G (zone 2) without marking and certification. The operating equipment is assigned to explosion group II B and temperature class T5.

Possible circuit according to DIN EN 60079-14

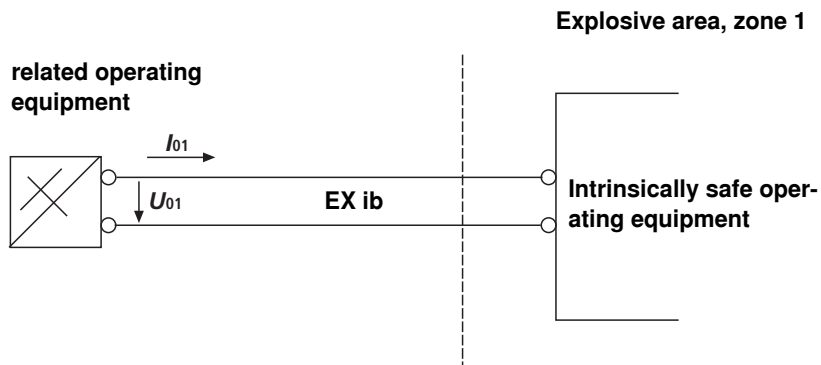

The manufacturer's declaration according to DIN EN 13463 is available for this filter separately, with Material no. R928028899.