

5/2-directional valve, Series 740-CP

- pipe connection
- Compressed air connection output : 3/8"
- Electrical connection : Plug, EN 175301-803, form B, 3-pin
- corrosion-protected
- Can be assembled into blocks
- Manual override : with detent, without detent
- single solenoid
- with air spring return
- Pilot : internal

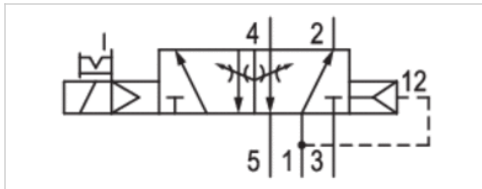

Version	Diaphragm poppet valve
Activation	electrically
Pilot	internal
Sealing principle	Soft sealing
Blocking principle	Plate principle, Single base plate principle
Working pressure min./max.	29 ... 145 psi
Ambient temperature min./max.	5 ... 122 °F
Medium temperature min./max.	5 ... 122 °F
Medium	Compressed air
Max. particle size	50 µm
Oil content of compressed air	0 ... 5 mg/m ³
Connector standard	EN 175301-803:2006
Protection class,with connection	IP65
Reverse polarity protection	Protected against polarity reversal
Compatibility index	14
Duty cycle	100 %
Typ. switch-on time	16 ms
Typ. switch-off time	36 ms
Mounting on manifold strip	PRS strip
Weight	0.719 lbs

Part No.	With valve plug connector	
R432015590	Without valve plug connector	1)
R432015613	Without valve plug connector	2)
R432015592	Without valve plug connector	1)
R432015614	Without valve plug connector	2)
R432015591	Without valve plug connector	1)
R432015594	Without valve plug connector	1)
R432015616	Without valve plug connector	2)
R432015593	Without valve plug connector	1)
R432015615	Without valve plug connector	2)

Nominal flow Q_n at 87 psi and $\Delta p = 14.5$ psi, MO = Manual override

1) Valve plug connector without status display

2) Valve plug connector with status display

Technical information

The min. control pressure must be adhered to, since otherwise faulty switching and valve failure may result!

The pressure dew point must be at least 27 °F under ambient and medium temperature and may not exceed 5.4 °F .

The oil content of compressed air must remain constant during the life cycle.

Use only the approved oils from AVENTICS. Further information can be found in the "Technical information" document (available in the MediaCentre).

ATEX optional: ATEX version can be produced by combining the basic valve without coil with an ATEX coil. ATEX ID: see ATEX coils catalog page.

Technical information

Material

Housing	Polyoxymethylene
Seals	Acrylonitrile butadiene rubber
Front plate	Polyarylamide

Dimensions

Dimensions in inches

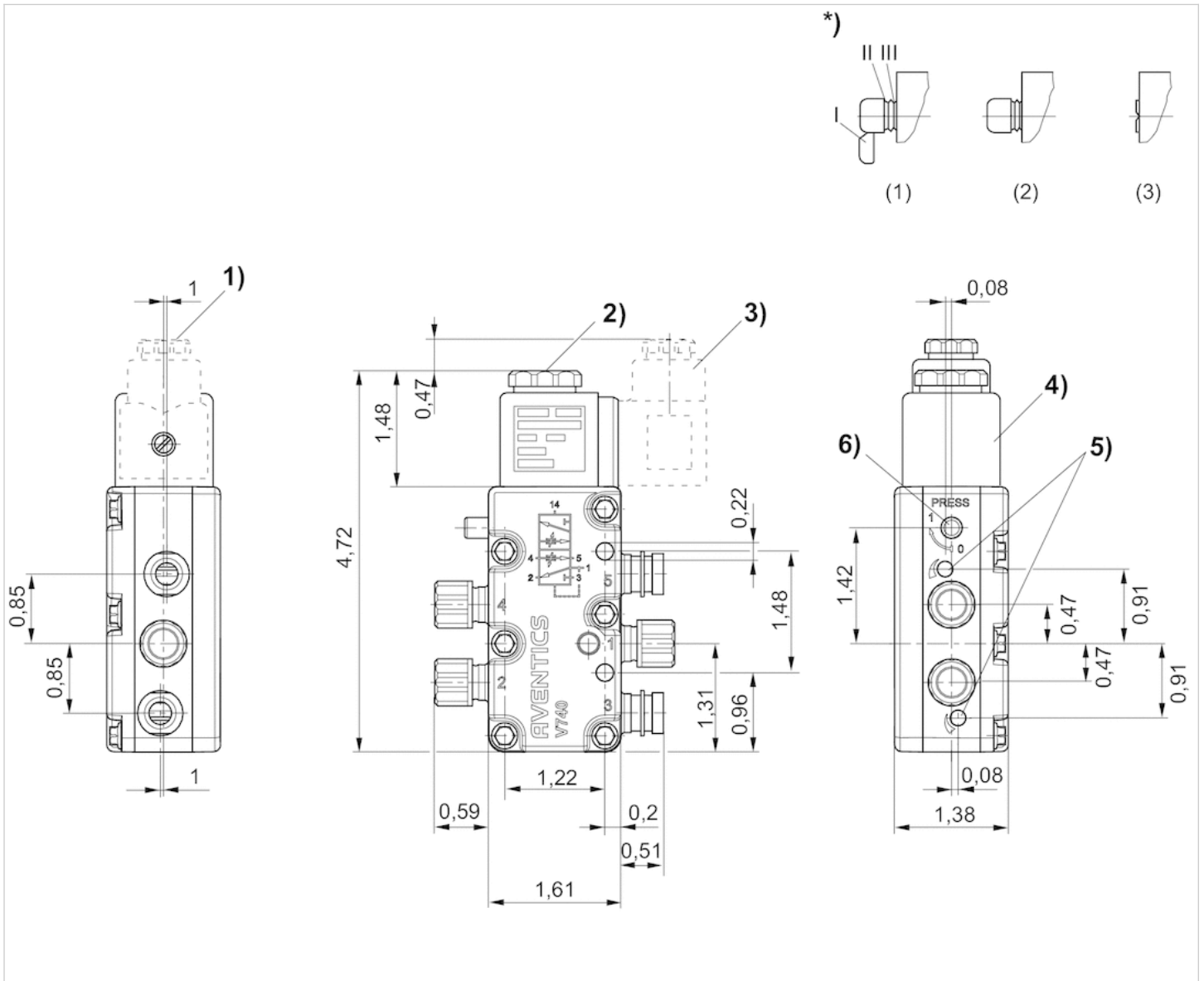

- 1) Gland fitting M16x1.52) M5 internal thread accessible under cap
 3) Valve plug connector can be rotated at 90° intervals
 4) Coil can be plugged at 45° intervals
 5) Flow control screw for exhausts 5 (R) and 3 (S)
 6) Manual override and position indicator*)
 Manual override: Manual actuation: (1) with detent - push and turn into position 1 (2) without detent - remove segment I - push only
 Actuation with tool: (3) with detent - remove segments up to II - push with tool and turn into position 1