

**STRAIGHT MALE RECEPTACLE SMT**  
**LIMITED DETENT-TAPE AND REEL BY 500**

**R222.941.300**

Series : SMP-COM

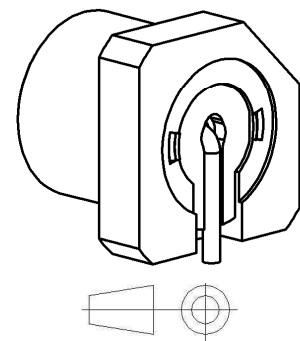
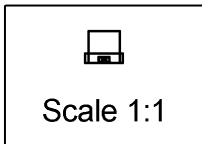
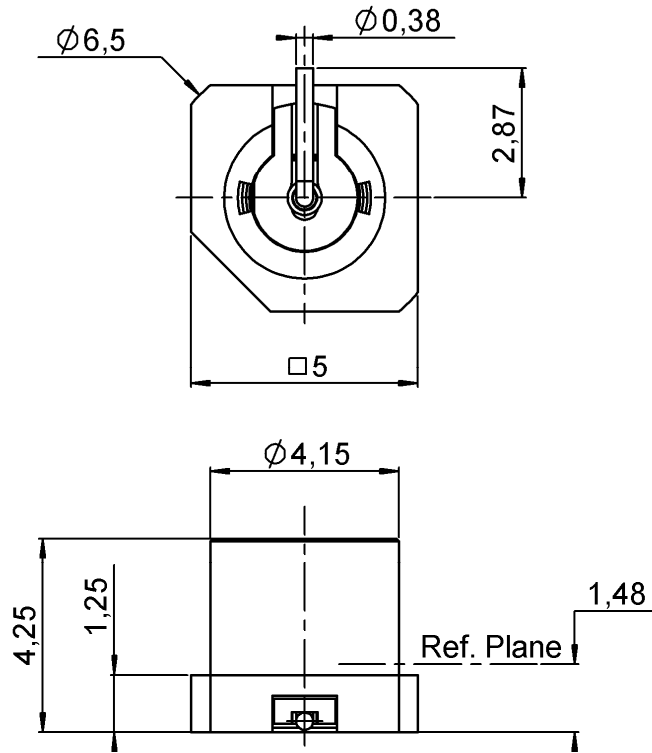

All dimensions are in mm.

COMPONENTS	MATERIALS	PLATING (µm)
BODY	BRASS	NPGR
CENTER CONTACT	BRASS	NPGR
OUTER CONTACT	-	-
INSULATOR	PEEK	-
GASKET	-	-
OTHERS PARTS	-	-
-	-	-
-	-	-

Issue : 0823 C

In the effort to improve our products, we reserve the right to make changes judged to be necessary.



**STRAIGHT MALE RECEPTACLE SMT**  
**LIMITED DETENT-TAPE AND REEL BY 500**

**R222.941.300**

Series : SMP-COM

**PACKAGING**

Standard	Unit	Other
500	'W' option	Contact us

**SPECIFICATION**

**ELECTRICAL CHARACTERISTICS**

Impedance		<b>50</b> Ω
Frequency		<b>0-12.4*</b> GHz
VSWR	<b>1.10**</b> +	<b>0,0000</b> x F(GHz) Maxi
Insertion loss		<b>0.12</b> √F(GHz) dB Maxi
RF leakage	- (	<b>NA</b> - F(GHz)) dB Maxi
Voltage rating		<b>335</b> Veff Maxi
Dielectric withstanding voltage		<b>500</b> Veff mini
Insulation resistance		<b>5000</b> MΩ mini

**ENVIRONMENTAL**

Operating temperature	<b>-55/+125</b> ° C
Hermetic seal	<b>NA</b> Atm.cm3/s
Panel leakage	<b>NA</b>

**OTHER CHARACTERISTICS**

Assembly instruction **NA**

Others :

\* ROS 1.35 at 12.4GHz

\*\*ROS at 6GHz

**MECHANICAL CHARACTERISTICS**

Center contact retention		
Axial force – Mating end	<b>6.8</b>	N mini
Axial force – Opposite end	<b>6.8</b>	N mini
Torque	<b>NA</b>	N.cm mini
Recommended torque		
Mating	<b>NA</b>	N.cm
Panel nut	<b>NA</b>	N.cm
Mating life	<b>100</b>	Cycles mini
Weight	<b>0,3310</b>	g

Issue : 0823 C

In the effort to improve our products, we reserve the right to make changes judged to be necessary.



**STRAIGHT MALE RECEPTACLE SMT**  
**LIMITED DETENT-TAPE AND REEL BY 500**

**R222.941.300**

Series : SMP-COM

**SOLDER PROCEDURE**

1. Deposit solder paste ‘SnAg4Cu0.5’ on mounting zone by screen printing application. We recommend a low residue flux.  
 We advise a thickness of 150 micromm ( 5.850 microinch ). Verify that the edges of the zone are clean.
2. Placement of the receptacle on the mounting zone with an automatic machine of ‘pick and place’ type. A video camera is recommended for positioning of the component . Adhesive agents must not be used on the receptacle.
3. This process of soldering has been tested with convection oven .Below please find ,the typical profile to use.
4. The cleaning of printed circuit boards is not obliged .
5. Verification of solder joints and position of the component by visual inspection.

**TEMPERATURE PROFILE**

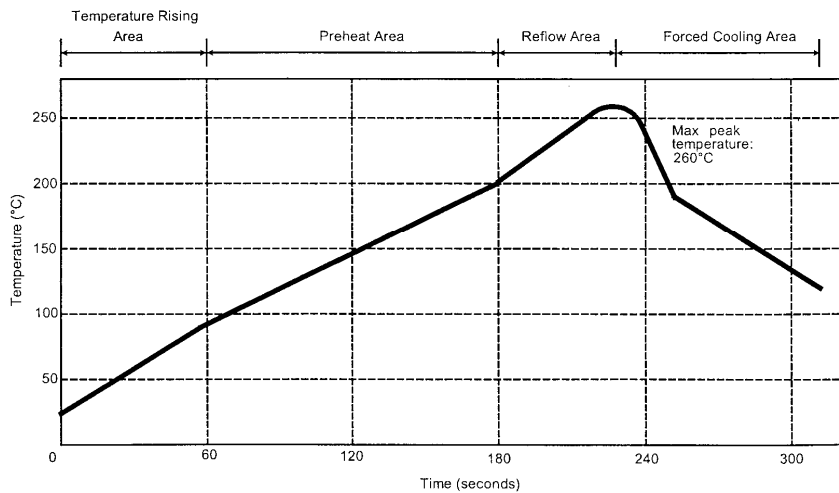

Parameter	Value	Unit
Temperature rising Area	1 - 4	°C/sec
Max Peak Temperature	260	°C
Max dwell time @260°C	10	sec
Min dwell time @235°C	20	sec
Max dwell time @235°C	60	sec
Temperature drop in cooling Area	-1 to - 4	°C/sec
Max dwell time above 100°C	420	sec

Issue : 0823 C

In the effort to improve our products, we reserve the right to make changes judged to be necessary.





**STRAIGHT MALE RECEPTACLE SMT**  
**LIMITED DETENT-TAPE AND REEL BY 500**

**R222.941.300**

Series : SMP-COM

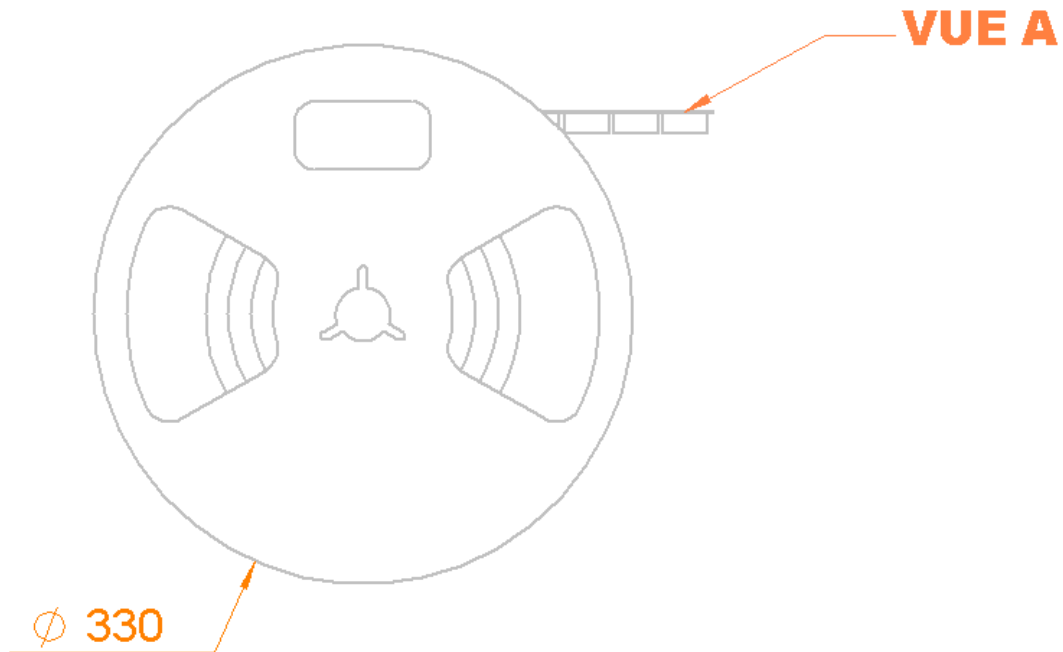

**Vue suivant A**

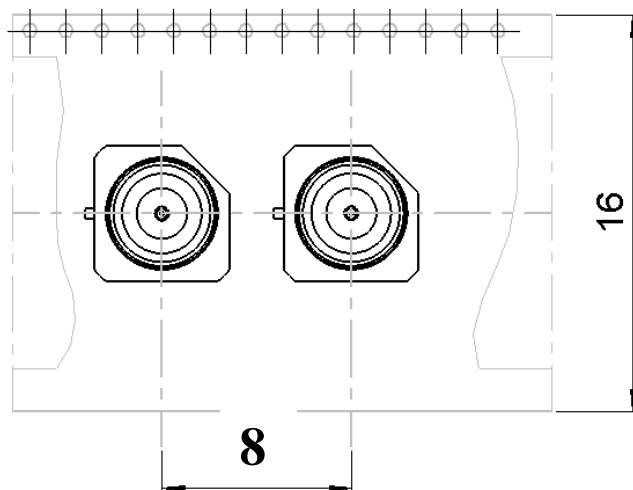

**AIR SUNCTION**

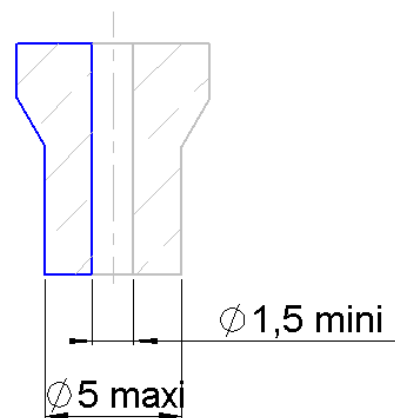

Issue : 0823 C

In the effort to improve our products, we reserve the right to make changes judged to be necessary.

