

Standard Runner Block R0442

All steel parts are made of rust and acid resistant material similar to ISO 683-17 / EN 10088.

Runner blocks are supplied on mandrels.

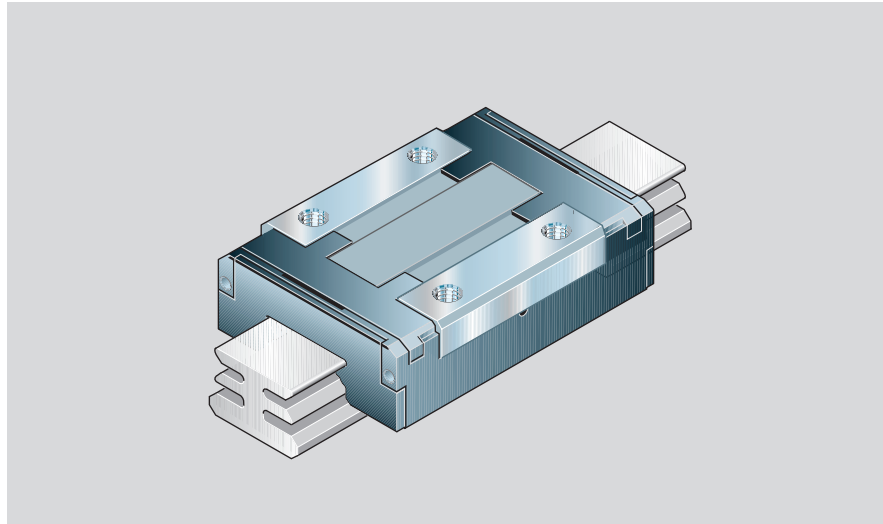

Part numbers for runner blocks

Standard seals: low-friction seals.
Part number: R0442 ... 01 (see table)

Special versions:

Runner blocks are also available:

- with N seals
(excellent wiping action)
Sizes 15 and 20 have additional longitudinal seals for full sealing.
Part number: R0442 ... 00
(otherwise as per table)
- without basic lubrication for individual lubrication.
- sizes 15 and 20 additionally with N seals and longitudinal seals
Part number: R0442 ... 40
(otherwise as per table)
- with low-friction seals
Part number: R0442 ... 41
(otherwise as per table)

Take frictional drag of the respective seals into account.

See chapter "Technical Data", section "Friction and seals".

Note on dynamic load capacities and moments (see table)

The dynamic load capacities and moments are based on 100,000 m travel.

However, a travel of just 50,000 is often taken as a basis.

If this is the case, for comparison purposes:

Multiply values C , M_t and M_L from the table by 1.26.

Size	Accuracy class	Part numbers for runner blocks	
		Clearance 9	Preload 1
7	P	–	R0442 712 01
	H	R0442 793 01	R0442 713 01
	N	R0442 794 01	–
9/M3	P	–	R0442 812 01
	H	R0442 893 01	R0442 813 01
	N	R0442 894 01	–
12	P	–	R0442 212 01
	H	R0442 293 01	R0442 213 01
	N	R0442 294 01	–
15	P	–	R0442 512 01
	H	R0442 593 01	R0442 513 01
	N	R0442 594 01	–
20	P	–	R0442 012 01
	H	R0442 093 01	R0442 013 01
	N	R0442 094 01	–

Ordering example 1:

Runner block size 12,
accuracy class P, preloaded, standard seals

Ordering data: R0442 212 01

Ordering example 2:

Runner block size 7,
accuracy class H, clearance, N seals

Ordering data: R0442 793 00

Ordering example 3:

Runner block size 15,
accuracy class H, preloaded, N seals and longitudinal seals, no basic lubrication

Ordering data: R0442 513 40

Ordering example 4:

Runner block size 9/M3,
accuracy class N, clearance, standard seals, no basic lubrication

Ordering data: R0442 894 41

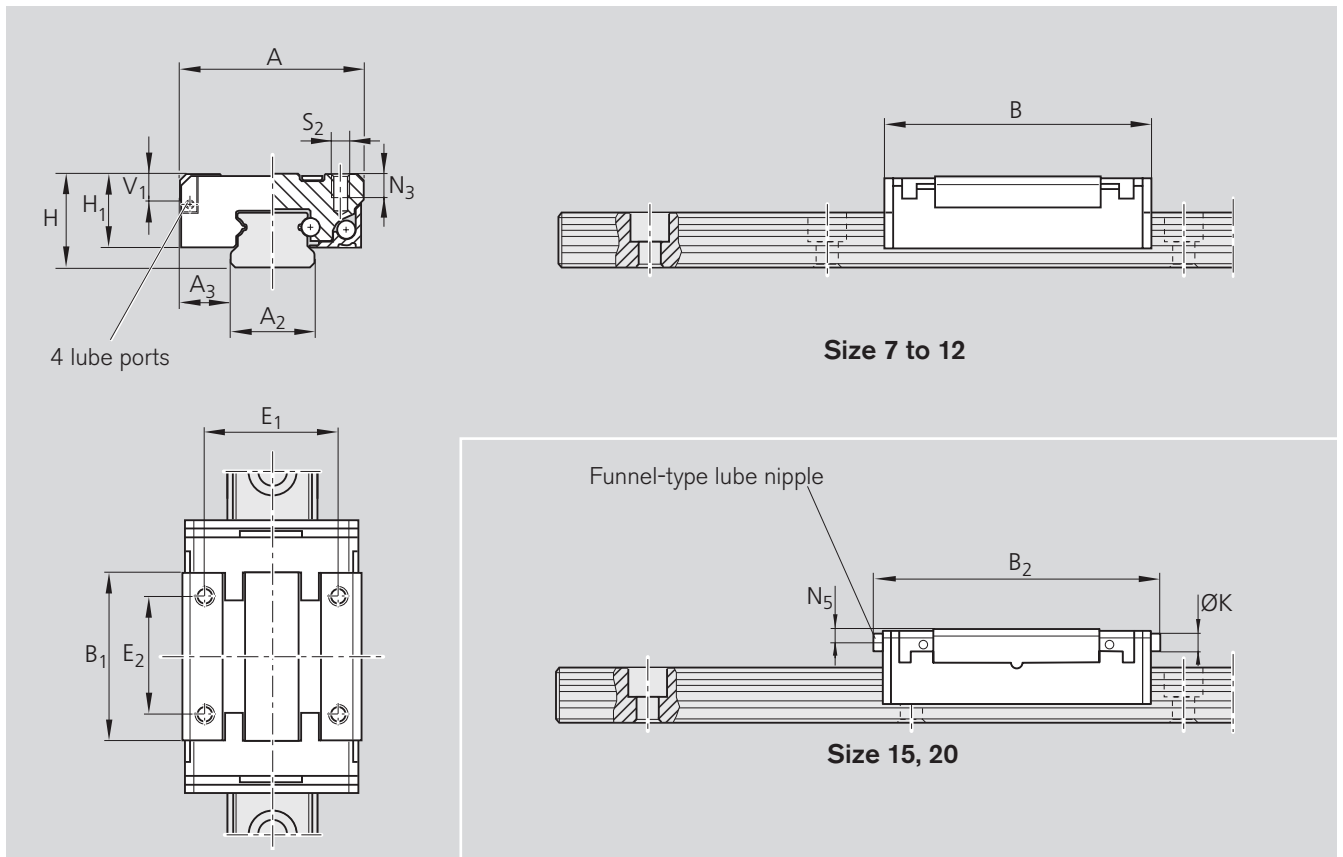

Size	Dimensions [mm]															
	A	A ₂	A ₃	B	B ₁	B ₂	H	H ₁ ¹⁾	H ₁ ²⁾	V ₁	E ₁	E ₂	K	N ₃	N ₅	S ₂
7	17	7	5.0	24.0	14.9	–	8	6.5	–	2.0	12	8	–	2.5	–	M2
9/M3	20	9	5.5	31.0	20.7	–	10	8.0	–	2.8	15	10	–	3.0	–	M3
12	27	12	7.5	34.8	21.6	–	13	10.0	–	3.3	20	15	–	3.5	–	M3
15	32	15	8.5	43.0	27.2	46	16	12.0	12.65	4.7	25	20	4	4.0	2.1	M3
20	46	20	13.0	66.0	45.1	69	25	17.5	18.15	7.0	38	38	4	6.0	3.1	M4

1) without longitudinal seal

2) with longitudinal seal

Size	Weight Runner blocks [g]	Load capacities [N]		Moments [Nm]			
		C ¹⁾ dyn.	C ₀ ¹⁾ stat.	M _t ²⁾		M _L ²⁾	
				dyn.	stat.	dyn.	stat.
7	9	860	1400	3.1	5.1	1.9	3.2
9/M3	16	1180	2100	5.4	9.6	3.6	6.4
12	33	2310	3470	13.7	20.6	7.9	11.8
15	47	4200	6260	31.2	46.3	18.3	27.0
20	177	7900	12230	81.4	126.0	51.7	80.0

1) Calculated values conforming to DIN 636 Part 2

2) Calculated values (based on C, C₀)