

PZ series

Piezoelectric keypads



DISTINCTIVE FEATURES

Very long life

Front or rear mounting

12 keys

Panel sealed to IP68

Custom markings on request



ENVIRONMENTAL SPECIFICATIONS

- Sealing : IP68 front and rear according to IEC 60529
- Operating and storage temperature :
-40 °C to +85 °C (-40 °F to +185 °F)
- Rapid temperature variation test according to IEC 68-2-14 test N
- Endurance test at extreme temperatures : 300.000 cycles
- Shock resistance according to NF EN 60068-2-27 : up to 90 G
- Abrasion test R3799 with Taber 5900 : 1.000.000 cycles min.
- Flame resistance : UL94 HB horizontal position (30 seconds max.)
- Salt spray : 96 hours according to IEC 68-2-11 test Ka
- Washability : most commonly used detergents and solvents



ELECTRICAL SPECIFICATIONS

- Output type : 4 x 3 matrix (NO contacts)
- Contact bounce time : 1ms max.
- Insulation resistance (OFF = not actuated) : 5 M Ω min.
- Initial contact resistance (ON = actuated) : 7.5 Ω max.
- Switching Voltage max. : 24 VDC
- Switching Current max. : 200 mA
- Electrical life : 10 million cycles min.
- ESD test : 20 KV max. according to IEC 1000-4-2

The company reserves the right to change specifications without notice.



PZ series

Piezoelectric keypads



GENERAL SPECIFICATIONS

- Actuating contact force : 2 to 4 N (depending on temperature)
- Stroke : none
- Mechanical life : 10 million cycles min.
- Connection : 8-pin male connector



MATERIALS

- Front panel : anodized aluminum
- Case : hard thermoplastic resin
- Sealing O-ring : neoprene
- Marking : chemically structured anodized silk screen with high abrasion resistance

APEM products may be recycled at end-of-life for the re-claiming of valuable metal components.



EXTRA FEATURES AVAILABLE ON REQUEST

- Specific marking including colors
- Backlighted version (under development)

PZ series

Piezoelectric keypads



BUILD YOUR PART NUMBER

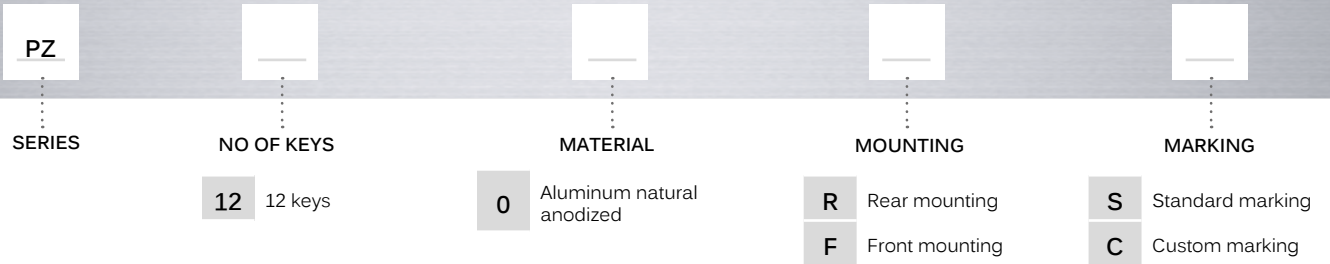

PZ series

Piezoelectric keypads

12-KEY MODEL - FRONT MOUNTING



PZ120FS

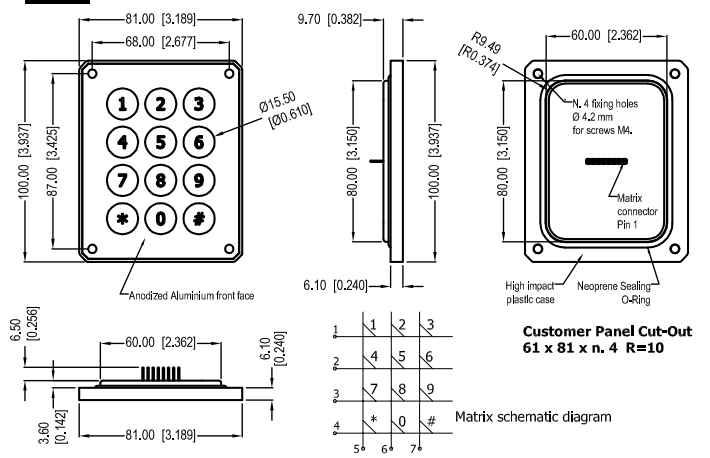

12-KEY MODEL - REAR MOUNTING



PZ120RS

