

SERIES: PYBE20 | DESCRIPTION: DC-DC CONVERTER
FEATURES

- up to 20 W isolated output
- industry standard pin-out
- 4:1 input range (9~36 Vdc, 18~75 Vdc)
- single/dual regulated outputs
- 1500 Vdc isolation
- continuous short circuit protection
- efficiency up to 90%
- operating temperature range (-40~+85°C)
- UL 60950-1 approval on select models



MODEL	input voltage		output voltage (Vdc)	output current		output power max (W)	ripple & noise ¹ max (mVp-p)	efficiency ² typ (%)
	typ (Vdc)	range (Vdc)		min (mA)	max (mA)			
PYBE20-Q24-S3	24	9~36	3.3	0	5000	16.5	100	86
PYBE20-Q24-S5	24	9~36	5	0	4000	20	100	88
PYBE20-Q24-S9	24	9~36	9	0	2222	20	100	89
PYBE20-Q24-S12	24	9~36	12	0	1667	20	100	89
PYBE20-Q24-S15	24	9~36	15	0	1333	20	100	90
PYBE20-Q24-S24	24	9~36	24	0	834	20	100	90
PYBE20-Q24-D5	24	9~36	±5	0	±2000	20	100	86
PYBE20-Q24-D9	24	9~36	±9	0	±1111	20	100	88
PYBE20-Q24-D12	24	9~36	±12	0	±834	20	100	88
PYBE20-Q24-D15	24	9~36	±15	0	±667	20	100	88
PYBE20-Q48-S3	48	18~75	3.3	0	5000	16.5	100	86
PYBE20-Q48-S5	48	18~75	5	0	4000	20	100	86
PYBE20-Q48-S9	48	18~75	9	0	2222	20	100	89
PYBE20-Q48-S12	48	18~75	12	0	1667	20	100	87
PYBE20-Q48-S15	48	18~75	15	0	1333	20	100	90
PYBE20-Q48-S24	48	18~75	24	0	834	20	100	88
PYBE20-Q48-D5	48	18~75	±5	0	±2000	20	100	86
PYBE20-Q48-D12	48	18~75	±12	0	±834	20	100	88
PYBE20-Q48-D15	48	18~75	±15	0	±667	20	100	89

- Notes:
1. From 5~100% load, nominal input, 20 MHz bandwidth oscilloscope, with 10 μ F tantalum and 1 μ F ceramic capacitors on the output. From 0~5% load, ripple and noise is <5% V_o .
 2. Measured at nominal input voltage, full load. The typical efficiencies for the chassis mount and DIN-rail mount versions are ~2% less than the board mount versions due to the input reverse polarity protection.
 3. All specifications are measured at $T_a=25^\circ\text{C}$, humidity < 75%, nominal input voltage, and rated output load unless otherwise specified.

PART NUMBER KEY

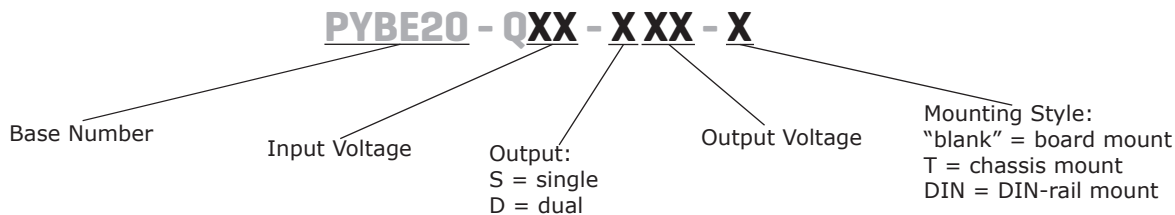

INPUT

parameter	conditions/description	min	typ	max	units
operating input voltage	24 Vdc input models	9	24	36	Vdc
	48 Vdc input models	18	48	75	Vdc
start-up voltage	24 Vdc input models			9	Vdc
	48 Vdc input models			18	Vdc
surge voltage	for maximum of 1 second				
	24 Vdc input models	-0.7		50	Vdc
	48 Vdc input models	-0.7		100	Vdc
under voltage shutdown	24 Vdc input models	5.5	6.5		Vdc
	48 Vdc input models	12	15.5		Vdc
current	24 Vdc input models	3.3 Vdc output models		818	mA
		5 Vdc output models		993	mA
	all other models		969	MA	
	48 Vdc input models	3.3 Vdc output models		409	mA
5 Vdc output models		497	mA		
all other models		485	mA		
remote on/off (CTRL) ⁴	turn on (3.5~12 Vdc or open circuit) turn off (<1.2 Vdc) input current when switched off		4	7	mA
filter	Pi filter				
input reverse polarity protection	only present on chassis mount and DIN-rail mount models				
no load power consumption			0.15		W

Notes: 4. The voltage of the CTRL pin is referenced to input GND pin.

OUTPUT

parameter	conditions/description	min	typ	max	units
maximum capacitive load ⁵	3.3, 5 Vdc output models			10,000	μF
	9 Vdc output models			4,700	μF
	12 Vdc output models			1,600	μF
	24 Vdc output models			500	μF
	±5 Vdc output models			4,800	μF
	15, ±9 Vdc output models			1,000	μF
	±12 Vdc output models			800	μF
	±15 Vdc output models			625	μF
voltage accuracy ⁶	0% to full load		±1	±3	%
line regulation	from low line to high line, full load				
	positive outputs		±0.2	±0.5	%
	negative outputs		±0.5	±1	%
load regulation ⁷	from 5% to full load				
	positive outputs		±0.5	±1	%
	negative outputs		±0.5	±1.5	%

Note: 5. Tested at input voltage range and full load.

6. At 0~5% load, the max output voltage accuracy for the ±5 & ±9 Vdc output models is ±5%.

7. At 0~100% load, the max load regulation is ±5%.

OUTPUT (CONTINUED)

parameter	conditions/description	min	typ	max	units
cross regulation	dual output models: main output 50% load secondary output from 10~100% load			±5	%
start-up time	nominal input, constant resistive load		10		ms
adjustability ⁸	see application notes		±10		%
switching frequency ⁹	PWM mode		270		kHz
transient recovery time	25% load step change, nominal input voltage		300	500	µs
transient response deviation	25% load step change, nominal input voltage 3.3, 5, ±5 Vdc output models all other models		±5 ±3	±8 ±5	% %
temperature coefficient	at full load			±0.03	%/°C

Note: 8. For single output models only.

9. Value is based on full load. At loads <50%, the switching frequency decreases with decreasing load

PROTECTIONS

parameter	conditions/description	min	typ	max	units
over voltage protection		110		160	%
over current protection		110		190	%
short circuit protection	hiccup, continuous, self recovery				

SAFETY AND COMPLIANCE

parameter	conditions/description	min	typ	max	units
isolation voltage	input to output for 1 minute at 1 mA	1,500			Vdc
isolation resistance	input to output at 500 Vdc	1,000			MΩ
isolation capacitance	input to output, 100 kHz / 0.1 V PYBE20-Q24-S24 all other models		2,050 1,050		pF pF
safety approvals ^{10, 11}	UL 60950-1, EN 62368-1				
conducted emissions	CISPR32/EN55032, class A (no external circuit); class B (external circuit required, see Figure 3-b, 4-b)				
radiated emissions	CISPR32/EN55032, class A (no external circuit); class B (external circuit required, see Figure 3-b, 4-b)				
ESD	IEC/EN61000-4-2, contact ± 4kV, class B				
radiated immunity	IEC/EN61000-4-3, 10V/m, class A				
EFT/burst	IEC/EN61000-4-4, ± 2kV, class B (external circuit required, see Figure 3-a, 4-a)				
surge	IEC/EN61000-4-5, line-line ± 2kV, class B (external circuit required, see Figure 3-a, 4-a)				
conducted immunity	IEC/EN61000-4-6, 3 Vr.m.s, class A				
voltage dips & interruptions	IEC/EN61000-4-29, 0%-70%, class B				
MTBF	as per MIL-HDBK-217F, 25°C	1,000,000			hours
RoHS	yes				

Note: 10. UL approval only for board mount models.

11. CE approval for all board mount, chassis mount, and DIN-rail mount models except for PYBE20-Q24-D9 versions.

ENVIRONMENTAL

parameter	conditions/description	min	typ	max	units
operating temperature	see derating curves	-40		85	°C
storage temperature		-55		125	°C
storage humidity	non-condensing	5		95	%
vibration	10~55 Hz, for 30 minutes on each axis		10		G

DERATING CURVES

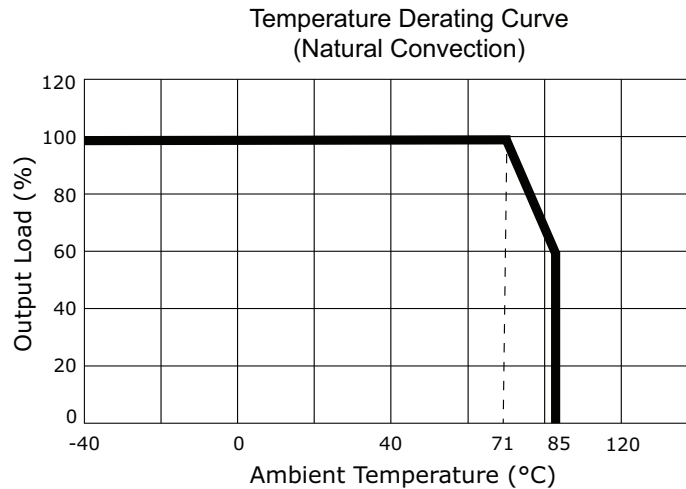

SOLDERABILITY¹²

parameter	conditions/description	min	typ	max	units
hand soldering	1.5 mm from case for 10 seconds			300	°C
wave soldering	see wave soldering profile			260	°C

Note: 12. For board mount models only.

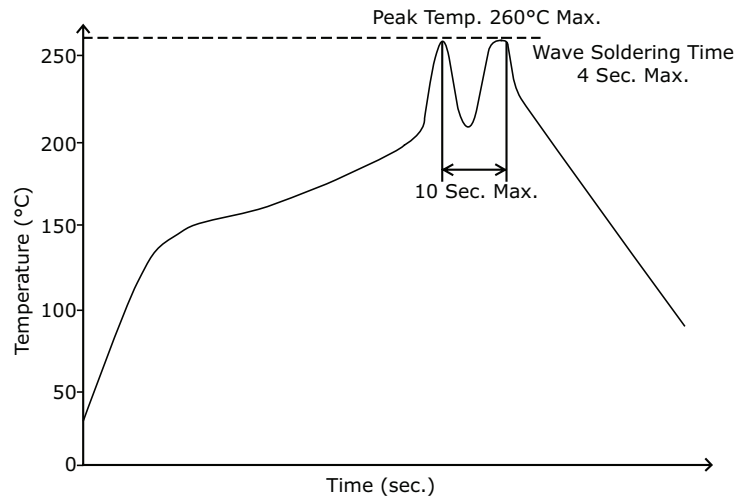

MECHANICAL

parameter	conditions/description	min	typ	max	units
dimensions	board mount: 50.80 x 25.40 x 11.80 [2.000 x 1.000 x 0.465 inch]				mm
	chassis mount: 76.00 x 31.50 x 21.20 [2.992 x 1.240 x 0.835 inch]				mm
	DIN-rail mount: 76.00 x 31.50 x 25.80 [2.992 x 1.240 x 1.016 inch]				mm
case material	aluminum alloy				
weight	board mount		25		g
	chassis mount		48		g
	DIN-rail mount		68		g

MECHANICAL DRAWING (BOARD MOUNT)

units: mm [inch]
 tolerance: ± 0.50 [± 0.020]
 pin diameter tolerance: ± 0.10 [± 0.004]

PIN CONNECTIONS		
PIN	Function	
	Single	Dual
1	GND	GND
2	Vin	Vin
3	+Vo	+Vo
4	trim	0V
5	0V	-Vo
6	CTRL	CTRL

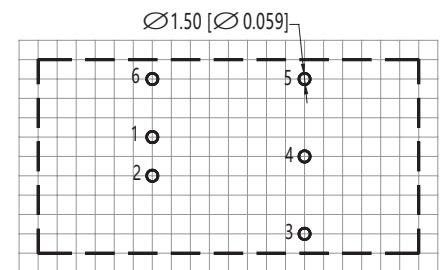
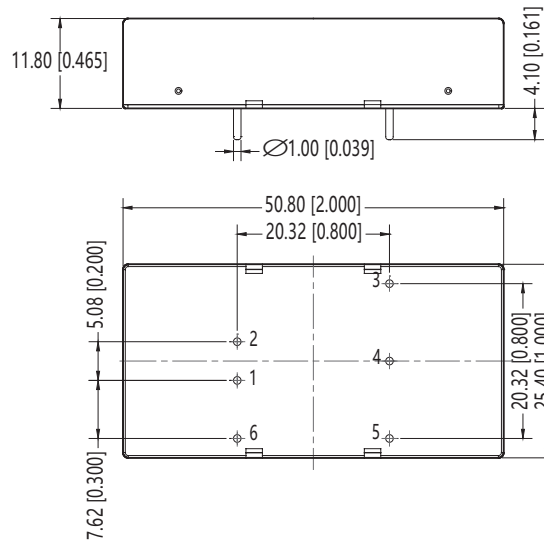

Note: Grid 2.54*2.54mm
 Recommended PCB Layout
 Top View

MECHANICAL DRAWING (CHASSIS MOUNT)

units: mm [inch]
tolerance: $\pm 0.50[\pm 0.020]$

wire range: 24~12 AWG
tightening torque: max 0.4 N*m

PIN CONNECTIONS		
PIN	Function	
	Single	Dual
1	CTRL	CTRL
2	GND	GND
3	Vin	Vin
4	0V	-Vo
5	trim	0V
6	+Vo	+Vo

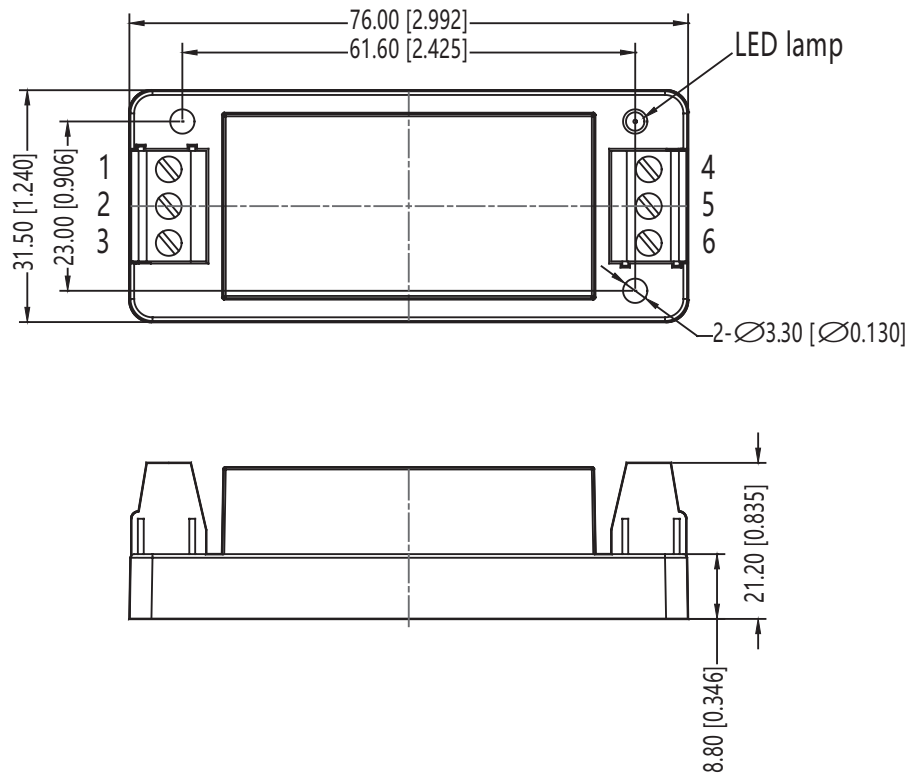

MECHANICAL DRAWING (DIN-RAIL MOUNT)

units: mm [inch]
tolerance: $\pm 0.50[\pm 0.020]$

installed on DIN rail TS35
wire range: 24~12 AWG
tightening torque: max 0.4 N*m

PIN CONNECTIONS		
PIN	Function	
	Single	Dual
1	CTRL	CTRL
2	GND	GND
3	Vin	Vin
4	0V	-Vo
5	trim	0V
6	+Vo	+Vo

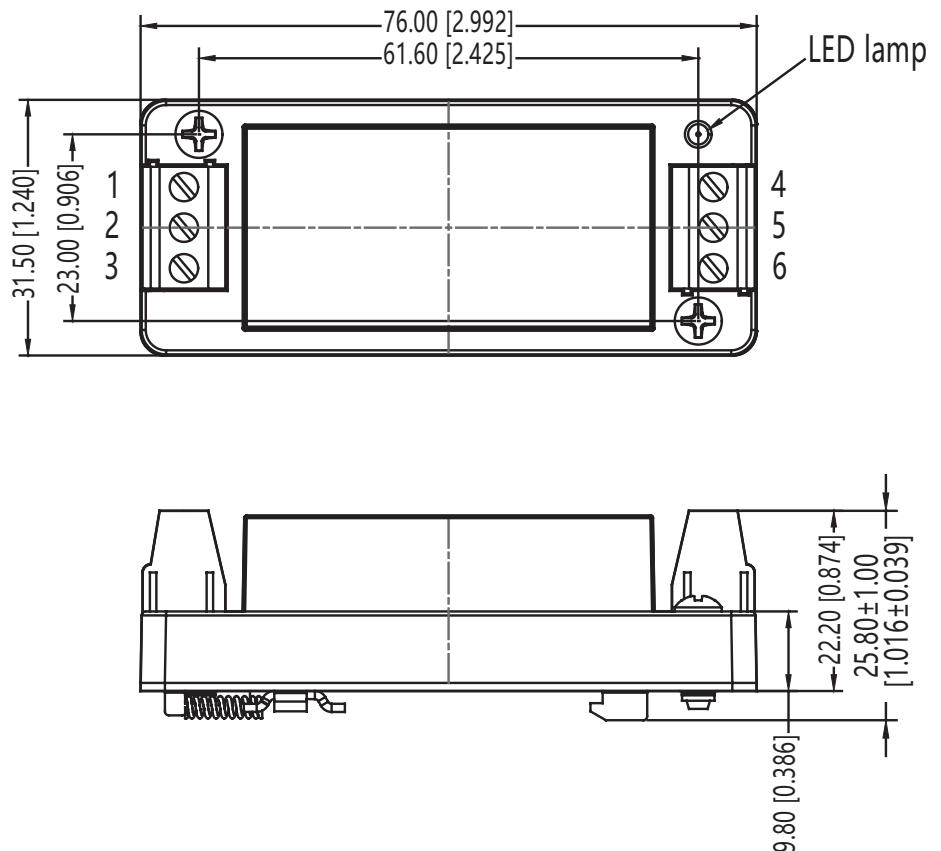

APPLICATION CIRCUIT

This series has been tested according to the following recommended circuits (Figures 1 & 2) before leaving the factory. If you want to further reduce the input and output ripple, you can increase the input and output capacitors or select capacitors of low equivalent impedance provided that the capacitance is less than the maximum capacitive load of the model.

Figure 1
Single Output Models



Figure 2
Dual Output Models



Table 1

Vout (Vdc)	Cin (μF)	Cout (μF)
3.3/5	100	470
9/12/15	100	220
24	100	100
±5	100	220
±9/±12/±15	100	100

EMC RECOMMENDED CIRCUIT

Figure 3
Single Output Models

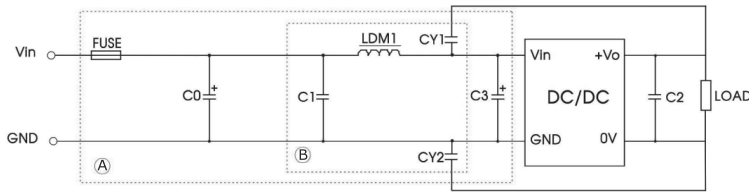

Figure 4
Dual Output Models

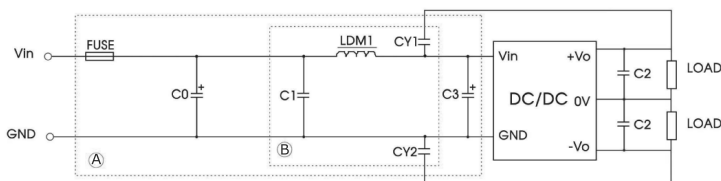

Table 2

Recommended External Circuit Components		
Vin (Vdc)	24	48
FUSE	choose according to actual input current	
C0, C3	330 μF / 50 V	330 μF / 100 V
C1	1 μF / 50 V	1 μF / 100 V
C2	Refer to the Cout in Table 1	
LDM1	4.7 μH / 3.1 A	
CY1, CY2	1 nF / 2 kV	

APPLICATION NOTES

Output voltage trimming
 Leave open if not used.

Figure 5

Application Circuit for Trim pin
 (part in broken line is the interior of models)

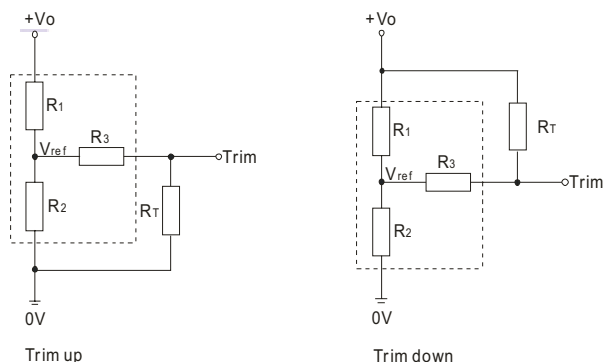

Formula for Trim Resistor

$$\text{up: } R_T = \frac{aR_2}{R_2 - a} - R_3 \quad a = \frac{V_{ref}}{V_{o'} - V_{ref}} \cdot R_1$$

$$\text{down: } R_T = \frac{aR_1}{R_1 - a} - R_3 \quad a = \frac{V_{o'} - V_{ref}}{V_{ref}} \cdot R_2$$

Note: Value for R1, R2, R3, and Vref refer to Table 3
 RT: Trim Resistor
 a: User-defined parameter, no actual meanings
 Vo': The trim up/down voltage

Table 3

Vout (Vdc)	R1 (kΩ)	R2 (kΩ)	R3 (kΩ)	Vref (V)
3.3	4.801	2.87	12.4	1.24
5	2.883	2.87	10	2.5
9	7.500	2.87	15	2.5
12	11.000	2.87	15	2.5
15	14.494	2.87	15	2.5
24	24.872	2.87	17.8	2.5

PACKAGING (BOARD MOUNT)

units: mm

Tube Size: 54.3 x 20 mm

Inner Carton Size: 575 x 135 x 100 mm

Outer Carton Size: 600 x 285 x 225 mm

Outer Carton QTY: 456 pcs

4 PCS of 22mm nails

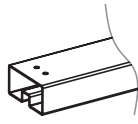

packaging tube

19 products in one packing tube

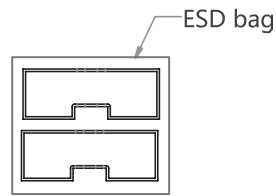
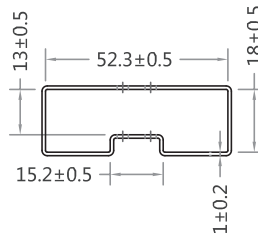

2 tubes in one ESD bag

Using rubber bands to tie the both ends of 2 tubes, then put into the ESD bag

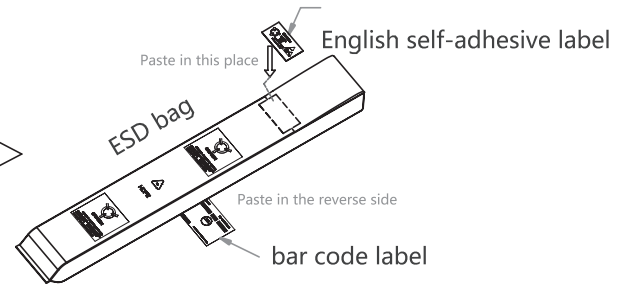
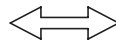

3 packages

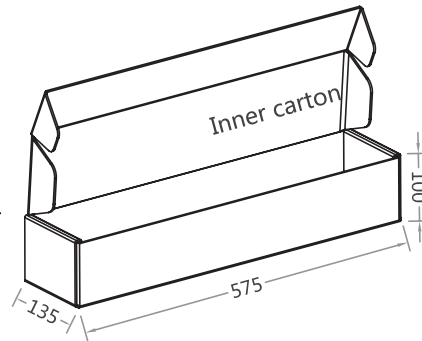
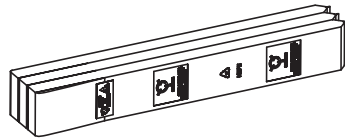

4 inner cartons

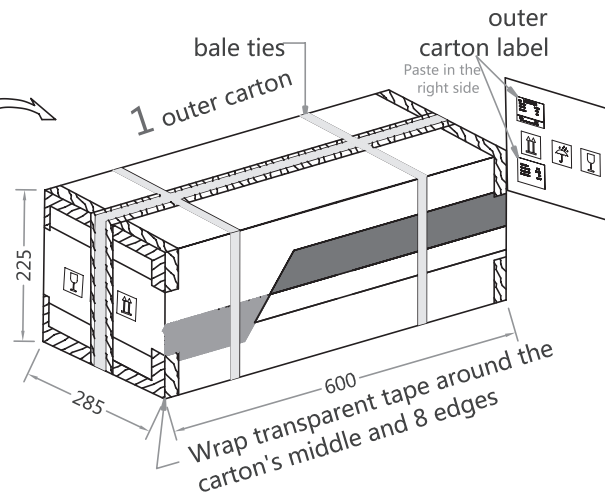
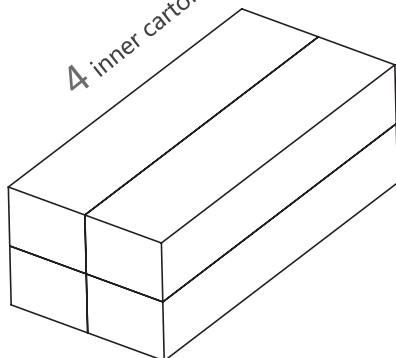

PACKAGING (CHASSIS, DIN-RAIL MOUNT)

units: mm

Inner Carton Size: 370 x 350 x 115 mm

Outer Carton Size: 400 x 365 x 255 mm

Outer Carton QTY: 96 pcs

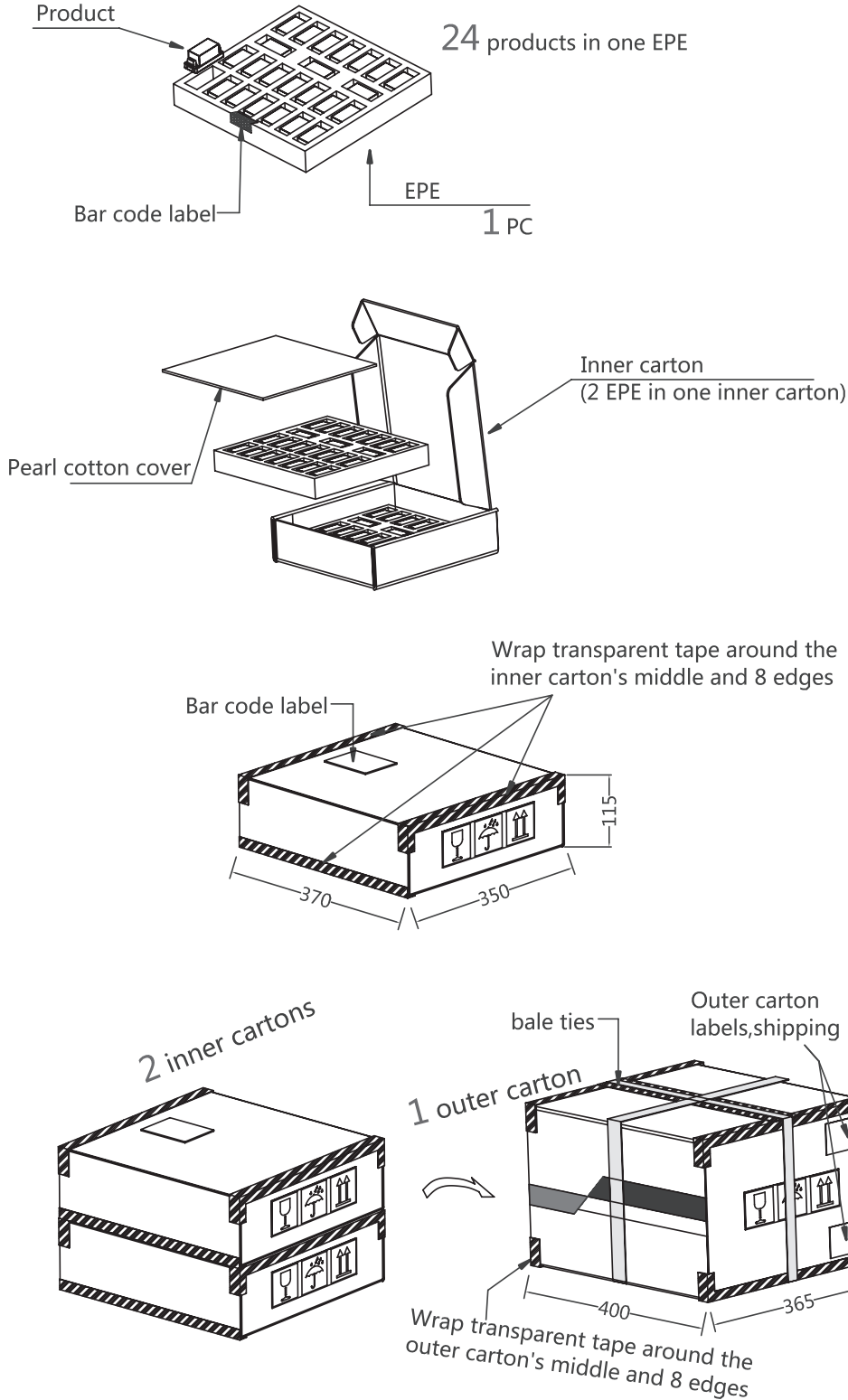

REVISION HISTORY

rev.	description	date
1.0	initial release	01/24/2019

The revision history provided is for informational purposes only and is believed to be accurate.



Headquarters
20050 SW 112th Ave.
Tualatin, OR 97062
800.275.4899

Fax 503.612.2383
cui.com
techsupport@cui.com

CUI offers a two (2) year limited warranty. Complete warranty information is listed on our website.

CUI reserves the right to make changes to the product at any time without notice. Information provided by CUI is believed to be accurate and reliable. However, no responsibility is assumed by CUI for its use, nor for any infringements of patents or other rights of third parties which may result from its use.

CUI products are not authorized or warranted for use as critical components in equipment that requires an extremely high level of reliability. A critical component is any component of a life support device or system whose failure to perform can be reasonably expected to cause the failure of the life support device or system, or to affect its safety or effectiveness.