

### Features

- 36 V to 75 V Input Voltage Range
- Programmable Output Voltage Range: 6.5 V to 17.5 V
- -40° to +85°C Ambient
- 1500 VDC Isolation
- 89% Efficiency
- On/Off Inhibit
- Differential Remote Sense
- N+1 Current Sharing
- Over-Current Protection
- Over-Temperature Protection
- Over-Voltage Protection
- Space-Saving Package
- Solderable Copper Case
- Safety Approvals:
  - UL 60950
  - CSA 22.2 950
  - VDE EN60950

### Description

The PT4485 Excalibur™ DC/DC converter module combines state-of-the-art power conversion technology with un-paralleled flexibility. Incorporating high efficiency and ultra-fast transient response, these modules provide up to 8.5 A of output current over the programmable voltage range of 6.5 V to 17.5 V. This represents 100-W output at 12 V.

The modules include a number of inbuilt features to facilitate system integration. These include a foldback output current limit, over-temperature protection, and an inhibit on/off control. A differential remote sense is also provided to compensate for voltage drop between the converter and load.

For applications requiring power supply redundancy, multiple PT4485 modules may be connected for operation in an 'N+1' configuration. Each PT4485 connected will share the load current with other active PT4485 modules.

### Ordering Information

PT4485□ = 6.5 to 17.5 Volts

### PT Series Suffix (PT1234 x)

Case/Pin Configuration	Order Suffix	Package Code *
Vertical	<b>N</b>	(EKD)
Horizontal	<b>A</b>	(EKA)
SMD	<b>C</b>	(EKC)

\* Previously known as package styles 1200, 1210, and 1215.

(Reference the applicable package code drawing for the dimensions and PC board layout)

### Pin-Out Information

Pin	Function	Pin	Function
1	+V <sub>in</sub>	14	-V <sub>out</sub>
2	-V <sub>in</sub>	15	-V <sub>out</sub>
3	Inhibit	16	-V <sub>out</sub>
4	Do not connect	17	-V <sub>out</sub>
5	Do not connect	18	-V <sub>out</sub>
6	Sync †	19	-V <sub>out</sub>
7	(+)Remote Sense	20	(-)Remote Sense
8	+V <sub>out</sub>	21	VID0
9	+V <sub>out</sub>	22	VID1
10	+V <sub>out</sub>	23	VID2
11	+V <sub>out</sub>	24	VID3
12	+V <sub>out</sub>	25	VID4
13	+V <sub>out</sub>	26	Share †

† Pins 6 & 26 are used for N+1 configuration (see related application note). For stand-alone operation, leave open circuit.

• Shaded functions indicate those pins that are referenced to primary-side potential.

### Standard Application

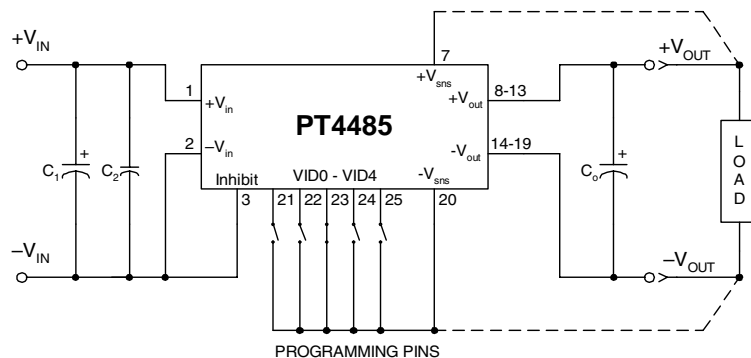

- C<sub>0</sub> = Optional 33-μF electrolytic capacitor
- C<sub>1</sub> = Optional 33-μF, 100-V electrolytic capacitor
- C<sub>2</sub> = Optional 1-μF, 100-V ceramic capacitor
- Programming pins, VID0–VID4, are shown configured for V<sub>o</sub> = 12 V
- For normal operation, pin 3 (Inhibit) must be connected to -V<sub>in</sub>.
- For details on additional N+1 components consult the related application note.

## Programming Information

VID3	VID2	VID1	VID0	VID4=1 Vout	VID4=0 Vout
1	1	1	1	10.0 V	6.50 V
1	1	1	0	10.5 V	6.75 V
1	1	0	1	11.0 V	7.00 V
1	1	0	0	11.5 V	7.25 V
1	0	1	1	12.0 V	7.50 V
1	0	1	0	12.5 V	7.75 V
1	0	0	1	13.0 V	8.00 V
1	0	0	0	13.5 V	8.25 V
0	1	1	1	14.0 V	8.50 V
0	1	1	0	14.5 V	8.75 V
0	1	0	1	15.0 V	9.00 V
0	1	0	0	15.5 V	9.25 V
0	0	1	1	16.0 V	9.50 V
0	0	1	0	16.5 V	9.75 V
0	0	0	1	17.0 V	10.00 V
0	0	0	0	17.5 V	10.25 V

Logic 0 = Connect to (-)Remote Sense, pin 20

Logic 1 = Open circuit (no pull-up resistors)

VID3 &amp; VID4 must not be changed while the unit is operating.

## PT4480 Series Comparison

	Functionality	Output Voltage Program Range	Configuration for Current Sharing
PT4481	Regulator	1.3 V– 3.5 V	N+1 with other PT4481s
PT4482	Regulator	1.3 V– 3.5 V	With PT4499 boosters
PT4499	PT4482 Booster	N/A	Used only with PT4482
PT4483	Regulator	4.6 V–5.7 V	N+1 with other PT4483s
PT4484	Regulator	4.6 V–5.7 V	With PT4498 boosters
PT4498	PT4484 Booster	N/A	Used only with PT4484
# PT4485	Regulator	6.5 V– 17.5 V	N+1 with other PT4485s
PT4486	Regulator	6.5 V–17.5 V	With PT4497 boosters
PT4497	PT4486 Booster	N/A	Used only with PT4486

# This specification covers only the PT4485 regulator.

Specifications (Unless otherwise stated,  $T_a = 25^\circ\text{C}$ ,  $V_{in} = 48\text{ V}$ ,  $V_o = 12\text{ V}$ ,  $C_o = 0\ \mu\text{F}$ , and  $I_o = I_{o,max}$ )

Characteristic	Symbol	Conditions	PT4485			Units
			Min	Typ	Max	
Output Current	$I_o$	Over $V_{in}$ range	0.1 <sup>(1)</sup>	—	8.5 <sup>(2)</sup>	A
Input Voltage Range	$V_{in}$	Over $I_o$ Range	36	48	75	VDC
Set Point Voltage Tolerance	$V_o\text{tol}$		—	$\pm 1$	$\pm 1.5$	% $V_o$
Temperature Variation	$\text{Reg}_{temp}$	$-40^\circ \leq T_{case} \leq +100^\circ\text{C}$ , $I_o = 0$	—	$\pm 0.5$	—	% $V_o$
Line Regulation	$\text{Reg}_{line}$	Over $V_{in}$ range	—	$\pm 0.1$	$\pm 1$	% $V_o$
Load Regulation	$\text{Reg}_{load}$	Over $I_o$ range	—	$\pm 0.5$	$\pm 1$	% $V_o$
Total Output Voltage Variation	$\Delta V_{o,tot}$	Includes set-point, line, load, $-40^\circ \leq T_{case} \leq +100^\circ\text{C}$	—	$\pm 2$	$\pm 3$	% $V_o$
Efficiency	$\eta$	$I_o = 5\text{ A}$	—	89	—	%
$V_o$ Ripple (pk-pk)	$V_r$	20 MHz bandwidth	—	120	150	mV <sub>pp</sub>
Transient Response	$t_{tr}$ $\Delta V_{tr}$	0.1 A/ $\mu\text{s}$ load step, 50% to 75% $I_{o,max}$ $V_o$ over/undershoot	—	N/A	—	$\mu\text{s}$ % $V_o$
		1 A/ $\mu\text{s}$ load step, 50% to 100% $I_{o,max}$ $V_o$ over/undershoot	—	200	—	$\mu\text{s}$ % $V_o$
Current Limit	$I_{lim}$	$V_{in} = 36\text{ V}$ , $\Delta V_o = -1\%$ foldback continuous limit	—	10	—	A
Current Share Tolerance	$I_{shr\ tol}$	with other PT4485 regulators in N+1	—	$\pm 10$	—	%
Over-Voltage Protection	OVP	Shutdown and latch off	—	125	—	% $V_o$
Switching Frequency	$f_s$	Over $V_{in}$ range	270	300	350	kHz
Under-Voltage Lockout	UVLO		—	34.5	—	V
Inhibit (Pin 3)	Input High Voltage Input Low Voltage Input Low Current	Referenced to $-V_{in}$ (pin 2)	$V_{IH}$	—	Open <sup>(3)</sup>	V
			$V_{IL}$	-0.5	—	
			$I_{IL}$	—	-0.2	
Standby Input Current	$I_{in\ standby}$	pins 3 & 2 connected	—	4	10	mA
Internal Input Capacitance	$C_{in}$		—	3	—	$\mu\text{F}$
External Output Capacitance	$C_{out}$	Between $+V_o$ and $-V_o$	0	—	10,000	$\mu\text{F}$
Isolation Voltage Capacitance Resistance		Input-output/input-case	1500	—	—	V
		Input to output	—	1100	—	pF
		Input to output	10	—	—	M $\Omega$
Operating Temperature Range	$T_c$	Case temperature, over $V_{in}$ range	-40	—	+100 <sup>(4)</sup>	$^\circ\text{C}$
Over-Temperature Shutdown	OTP	Case temperature, auto reset	—	110	—	$^\circ\text{C}$
Storage Temperature	$T_s$		-40	—	+125	$^\circ\text{C}$
Reliability	MTBF	Per Bellcore TR-332 50% stress, $T_a = 40^\circ\text{C}$ , ground benign	1.7	—	—	10 <sup>6</sup> Hrs
Mechanical Shock	—	Per Mil-Std-883D, method 2002.3, 1mS, half-sine, mounted to a fixture	—	500	—	G's
Mechanical Vibration	—	Mil-Std-883D, Method 2007.2 20-2000 Hz, pcb mounted	Horizontal	—	20 <sup>(5)</sup>	G's
Weight	—		—	90	—	grams
Flammability	—	Materials meet UL 94V-0				

**Notes:** (1) The converter requires a 100 mA load to ensure proper operation.(2) The maximum output current is limited to 8.5 A or  $100/V_{OUT}$ , whichever is less.(3) The Inhibit (pin 3) has an internal pull-up, and must be pulled to  $-V_{in}$  potential to enable the output. If it is left open circuit the converter output will be disabled. The open-circuit voltage is limited to 6.5 V. Refer to the application notes for other interface considerations.

(4) See Safe Operating Area curves or contact the factory for the appropriate derating.

(5) The case pins on through-hole pin configuration (suffix A) must be soldered. For more information see the applicable package outline drawing.

Performance Characteristics,  $V_o = 12\text{ V}$  (See Note A)

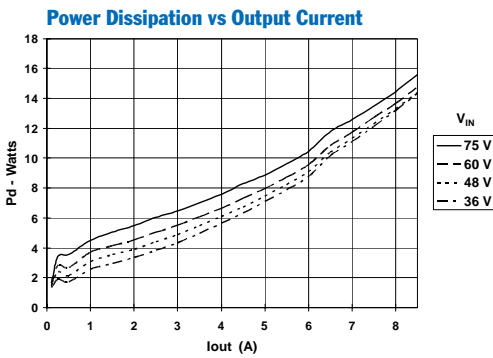
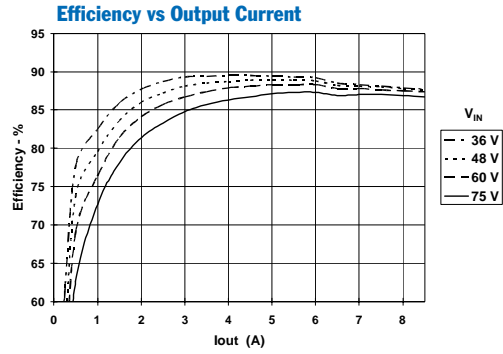

Safe Operating Area,  $V_o = 12\text{ V}$ ,  $V_{in} = 48\text{ V}$  (See Note B)

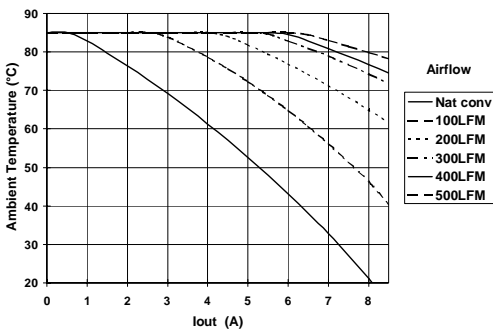

Performance Characteristics,  $V_o = 15\text{ V}$  (See Note A)

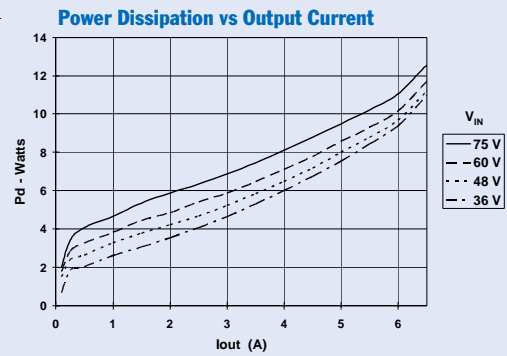
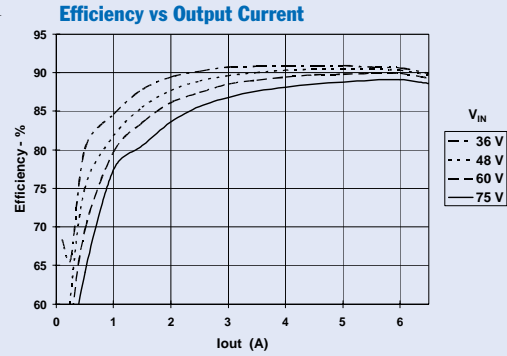

Safe Operating Area,  $V_o = 15\text{ V}$ ,  $V_{in} = 48\text{ V}$  (See Note B)

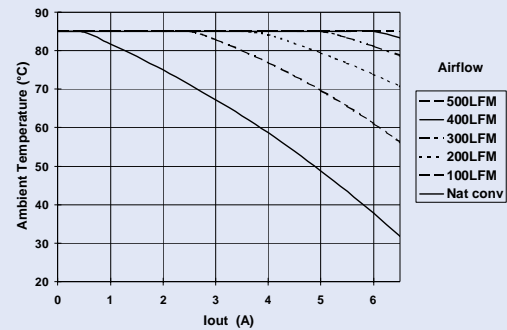

**Note A:** Characteristic data has been developed from actual products tested at 25°C. This data is considered typical data for the Converter.

**Note B:** SOA curves represent the conditions at which internal components are at or below the manufacturer's maximum operating temperatures

## Configuring PT4485 DC/DC Converters for N+1 Operation

### 'N+1' vs OR'ing

The PT4485 DC/DC converter modules may be operated with other PT4485 modules in 'N+1' configurations. A simple OR'ing connection allows a number of converters to share the load current. An 'N+1' configuration adds redundancy by employing at least one more converter than is necessary to supply the load. This ensures that upon the loss of one converter, sufficient capacity remains to supply the load without interruption. As an example, a 15-A load configured for 'N+1' would require no less than three PT4485 converters. Two are needed to meet the load demand, plus one additional converter to ensure redundancy. Figure 1-1 shows the schematic for operating two PT4485 converters in an 'N+1' configuration for a 7.5-A load application.

### Blocking Diodes

A true 'N+1' redundant system must also protect the output bus against fault current back-feeding a converter. Without a blocking diode, the PT4485 converters can potentially sink current as a result of a fault at the output. The blocking diodes <sup>4</sup>, (D<sub>1</sub> & D<sub>2</sub> in Figure 1-1), protect against reverse current flow under such conditions.

### Notes

1. For 'N+1' redundancy, always use one more converter than is required to supply the load.
2. The VID pins for all converter modules must be independently set to the same voltage program code.
3. **All converters connected for 'N+1' operation must be located on the same printed circuit board.** A similar footprint and trace layout for each converter will facilitate current sharing.
4. A number of high-current rectifier diodes are available with a low forward voltage drop. They are specifically designed for OR'ing applications in 'N+1' systems. Eg. The 82CNQ030, and MBRB2515.
5. As a result of excess capacity and the losses in the blocking diodes, system efficiency is reduced.
6. The interconnection of pin 6 (Sync), and pin 26 (Share) between all modules are required for load current sharing and operation at a common frequency.

Figure 1-1; Connection Schematic for Operation in Parallel/N+1 Configuration

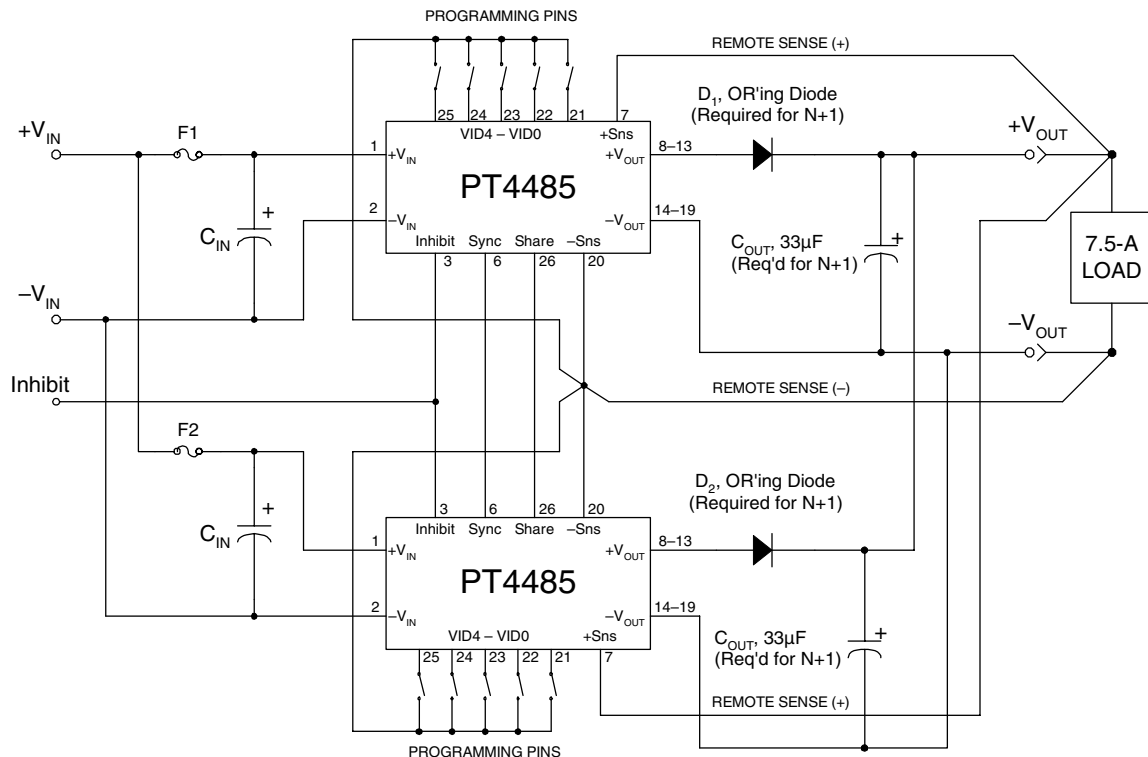

## Operating Features of the PT4470 and PT4480 Series of Isolated DC/DC Converters

### Under-Voltage Lockout

An Under-Voltage Lock-Out (UVLO) inhibits the operation of the converter until the input voltage is above the UVLO threshold (see the applicable data sheet specification). Below this voltage, the module's output is held off, irrespective of the state of the *Inhibit* control (pin 3). If the *Inhibit* control is connected to  $-V_{in}$  (pin 2), the module will automatically power up when the input voltage rises above the UVLO threshold. The UVLO allows the module to produce a clean transition during both power-up and power-down, even when the input voltage is rising or falling slowly. It also reduces the high start-up current during normal power-up of the converter, and minimizes the current drain from the input source during low-input voltage conditions. The UVLO threshold includes about 2 V of hysteresis. Once operational, the converter will conform to its operating specifications when the minimum specified input voltage is reached.

### Over-Current Protection

To protect against load faults, the PT4470/80 series of DC/DC converters incorporate an output current limit. Once the load current drawn from the module reaches the current limit threshold, any attempt by the load to draw additional current will result in a significant drop in the module's regulated output voltage. The current limit circuitry incorporates a limited amount of foldback. This has the effect of slightly reducing the output current from the module when supplying an absolute short circuit. Upon removal of the load fault, the output voltage from the converter will automatically recover to its programmed regulation voltage.

### Output Over-Voltage Protection

The PT4470/80 series of DC/DC converters incorporate circuitry that continually senses the output for an over-voltage (OV) condition. The OV threshold automatically tracks the VID output voltage program setting to a level 25% higher than that programmed at the control pins, VID0 through VID4. If the converter output voltage exceeds the OV threshold, the converter is immediately shut down and remains in a latched-off state. To resume normal operation the converter must be actively reset. This is accomplished by either cycling the status of the *Inhibit* control (pin 3) from "On" to "Off" and then back "On" again, or by momentarily removing the input power to the converter. For failsafe operation and redundancy, the OV protection uses circuitry that is independent of the converter's internal feedback loop.

### Over-Temperature Protection

Over-temperature protection is provided by an internal temperature sensor, which closely monitors the temperature of the converter's metal case. If the case temperature exceeds the specified limit (see applicable data sheet), the converter will shut down. The converter will then automatically restart when the sensed temperature drops by about 10°C. When operated outside its recommended thermal derating envelope (see data sheet SOA curves), the converter will typically cycle on and off at intervals from a few seconds to one or two minutes. This is to ensure that the internal components are not permanently damaged from excessive thermal stress.

### Primary-Secondary Isolation

Electrical isolation is provided between the input terminals (primary) and the output terminals (secondary). All converters are production tested to a primary-secondary withstand voltage of 1500VDC. This specification complies with UL60950 and EN60950 and the requirements for operational isolation. Operational isolation allows these converters to be configured for either a positive or negative input voltage source. The data sheet 'Pin-Out Information' uses shading to indicate which pins are associated with the primary. They include pins 1 through 5, inclusive.

### Fuse Recommendations

If desired, an input fuse may be added to protect against the application of a reverse input voltage.

### Thermal Considerations

Airflow may be necessary to ensure that the module can supply the desired load current in environments with elevated ambient temperatures. The required airflow rate may be determined from the Safe Operating Area (SOA) thermal derating chart (see converter specifications). The recommended direction for airflow is into the longest side of the module's metal case. See Figure 1.

Figure 1

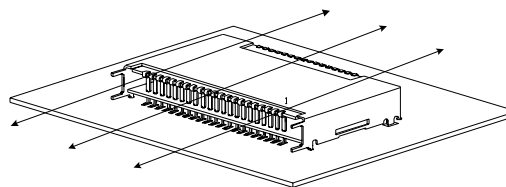

Recommended direction for airflow is into (perpendicular to) the longest side.

### Using the Inhibit Function on the PT4470 & PT4480 Series of Isolated DC/DC Converters

The PT4470/44480 series of DC/DC converters incorporate an On/Off Inhibit function. This function may be used in applications that demand battery conservation, power-up/shutdown sequencing, and/or to coordinate power-up for active in-rush current control.

The On/Off feature is provided by the *Inhibit* control, pin 3. The *Inhibit* pin of the PT4470/4480 series of converters is an active low enable. The pin must be either connected, or actively pulled low, to  $-V_{in}$  (pin 2) to enable the converter output (see standard application schematic). When pins 2 & 3 are connected, the converter provides a regulated output whenever a valid source voltage<sup>3</sup> is applied between  $+V_{in}$  (pin 1), and  $-V_{in}$  (pin 2). If pin 3 is disconnected, or allowed to become high impedance, the regulator output will be disabled.<sup>5</sup>

Table 2-1 provides details of the interface requirements for the *Inhibit* pin. Figure 2-1 shows how a discrete MOSFET ( $Q_1$ )<sup>4</sup>, may be referenced to  $-V_{in}$  and used to control the input.

**Table 2-1 Inhibit Control Requirements**

Parameter	Min	Max
Enable ( $V_{IH}$ )	-0.5 V	0.8 V
Disable ( $V_{IL}$ )	2.5 V	(Open Circuit)

#### Notes:

- The *Inhibit* control uses  $-V_{in}$  (pin 2), on the primary side of the converter, as its ground reference. All voltages specified are with respect to  $-V_{in}$ .
- The internal circuitry is simple pull-up resistor. The open-circuit voltage may be as high as 6.5 Vdc.
- These converters incorporate an “Under-Voltage Lockout” (UVLO) function. This function automatically disables the converter output until there is sufficient input voltage to produce a regulated output. Table 2 gives the applicable UVLO thresholds.

**Table 2-2 UVLO Thresholds<sup>1</sup>**

Series	UVLO Threshold	$V_{in}$ Range
PT4470	17 V Typical	18 – 36 V
PT4480	34.5 V Typical	36 – 75 V

- The *Inhibit* input must be controlled with an open-collector (or open-drain) discrete transistor or MOSFET. Do not use a pull-up resistor.
- When the converter output is disabled, the current drawn from the input supply is typically reduced to 4 mA (10 mA maximum).

- Keep the on/off transition to less than 1ms. This prevents erratic operation of the ISR, whereby the output voltage may drift un-regulated between 0 V and the rated output during power-up.

**Figure 2-1**

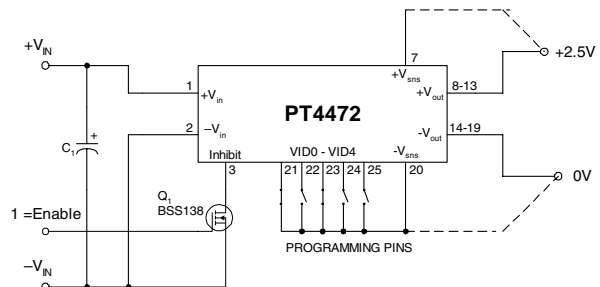

**Turn-On Time:** With input power applied, the converter typically produces a fully regulated output voltage within 25 ms after applying a low-voltage signal to the *Inhibit* control pin. The actual turn-on time will vary with the input voltage, output load, and the total amount of capacitance connected to the output. Using the circuit of Figure 2-1, Figure 2-2 shows the typical output voltage and input current waveforms of a PT4472 after  $Q_1$  is turned on. The turn on of  $Q_1$  correlates to the fall in  $V_{inh}$ . The output voltage was set to 2.5 V. The waveform was measured with a 48-Vdc input voltage, and 15-A load current.

**Figure 2-2**

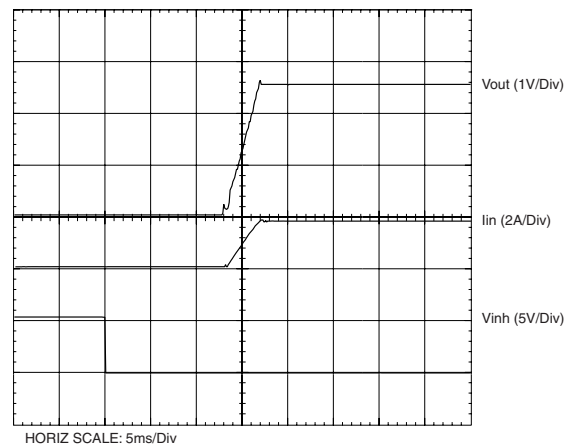

## VDE Approved Installation Instructions (Installationsanleitung)

Nennspannung (Rated Voltage):	PT4450, 70, and 93-95 series PT4460, 80, and 97-99 series	18-36Vdc 36-75Vdc
Nennaufnahme (Rated Input):	PT4450, 70, and 93-95 series PT4460, 80, and 97-99 series	6.8Adc 3.4Adc
Nennleistung (Rated Power):	PT4450, 60, 80, and 90 series	100W max
Ausgangsspannung (Sec. Voltage):	PT4451, 52, 61, 62, 71, 72, 81, 82, 99 3.3V/30A/100W PT4453, 54, 63, 64, 73, 74, 83, 84, 94, 98 5.7V/20A/100W	
Ausgangsstrom (Sec. Current): oder (or)	PT4455, 56, 65, 66, 75, 76, 85, 86, 93, 97 17.5V/8.3A/100W	
Ausgangsleistung (Sec. Power):		

### Angabe der Umgebungstemperatur

(Information on ambient temperature): +85 °C maximum

### Besondere Hinweise (Special Instructions):

Es ist vorzusehen, daß die Spannungsversorgung in einer Endanwendung über eine isolierte Sekundärschaltung bereit gestellt wird. Die Eingangsspannung der Spannungsversorgungsmodule muss eine verstärkte Isolierung von der Wechselstromquelle aufweisen.

Die Spannungsversorgung muss gemäß den Gehäuse-, Montage-, Kriech- und Luftstrecken-, Markierungs- und Trennanforderungen der Endanwendung installiert werden. Bei Einsatz eines TNV-3-Einganges muss die SELV-Schaltung ordnungsgemäß geerdet werden.

(The power supply is intended to be supplied by isolated secondary circuitry in an end use application. The input power to these power supplies shall have reinforced insulation from the AC mains.)

The power supply shall be installed in compliance with the enclosure, mounting, creepage, clearance, casualty, markings, and segregation requirements of the end-use application. When the input is TNV-3, the SELV circuitry must be reliably grounded.)

Offenbach, 8.8.02

**VDE Prüf- und Zertifizierungsinstitut**  
Abteilung / Department TD

(Jürgen Bärwinkel)

Ort / Place: Datum / Date: 5/29/02

(Stempel und Unterschrift des Herstellers / Stamp and signature of the manufacturer)

**PACKAGING INFORMATION**

Orderable Device	Status <sup>(1)</sup>	Package Type	Package Drawing	Pins	Package Qty	Eco Plan <sup>(2)</sup>	Lead/Ball Finish	MSL Peak Temp <sup>(3)</sup>
PT4485A	NRND	SIP MOD ULE	EKA	26	6	TBD	Call TI	Level-1-215C-UNLIM
PT4485N	NRND	SIP MOD ULE	EKD	26	6	TBD	Call TI	Level-1-215C-UNLIM

<sup>(1)</sup> The marketing status values are defined as follows:

**ACTIVE:** Product device recommended for new designs.

**LIFEBUY:** TI has announced that the device will be discontinued, and a lifetime-buy period is in effect.

**NRND:** Not recommended for new designs. Device is in production to support existing customers, but TI does not recommend using this part in a new design.

**PREVIEW:** Device has been announced but is not in production. Samples may or may not be available.

**OBsolete:** TI has discontinued the production of the device.

<sup>(2)</sup> Eco Plan - The planned eco-friendly classification: Pb-Free (RoHS), Pb-Free (RoHS Exempt), or Green (RoHS & no Sb/Br) - please check <http://www.ti.com/productcontent> for the latest availability information and additional product content details.

**TBD:** The Pb-Free/Green conversion plan has not been defined.

**Pb-Free (RoHS):** TI's terms "Lead-Free" or "Pb-Free" mean semiconductor products that are compatible with the current RoHS requirements for all 6 substances, including the requirement that lead not exceed 0.1% by weight in homogeneous materials. Where designed to be soldered at high temperatures, TI Pb-Free products are suitable for use in specified lead-free processes.

**Pb-Free (RoHS Exempt):** This component has a RoHS exemption for either 1) lead-based flip-chip solder bumps used between the die and package, or 2) lead-based die adhesive used between the die and leadframe. The component is otherwise considered Pb-Free (RoHS compatible) as defined above.

**Green (RoHS & no Sb/Br):** TI defines "Green" to mean Pb-Free (RoHS compatible), and free of Bromine (Br) and Antimony (Sb) based flame retardants (Br or Sb do not exceed 0.1% by weight in homogeneous material)

<sup>(3)</sup> MSL, Peak Temp. -- The Moisture Sensitivity Level rating according to the JEDEC industry standard classifications, and peak solder temperature.

**Important Information and Disclaimer:**The information provided on this page represents TI's knowledge and belief as of the date that it is provided. TI bases its knowledge and belief on information provided by third parties, and makes no representation or warranty as to the accuracy of such information. Efforts are underway to better integrate information from third parties. TI has taken and continues to take reasonable steps to provide representative and accurate information but may not have conducted destructive testing or chemical analysis on incoming materials and chemicals. TI and TI suppliers consider certain information to be proprietary, and thus CAS numbers and other limited information may not be available for release.

In no event shall TI's liability arising out of such information exceed the total purchase price of the TI part(s) at issue in this document sold by TI to Customer on an annual basis.

## IMPORTANT NOTICE

Texas Instruments Incorporated and its subsidiaries (TI) reserve the right to make corrections, modifications, enhancements, improvements, and other changes to its products and services at any time and to discontinue any product or service without notice. Customers should obtain the latest relevant information before placing orders and should verify that such information is current and complete. All products are sold subject to TI's terms and conditions of sale supplied at the time of order acknowledgment.

TI warrants performance of its hardware products to the specifications applicable at the time of sale in accordance with TI's standard warranty. Testing and other quality control techniques are used to the extent TI deems necessary to support this warranty. Except where mandated by government requirements, testing of all parameters of each product is not necessarily performed.

TI assumes no liability for applications assistance or customer product design. Customers are responsible for their products and applications using TI components. To minimize the risks associated with customer products and applications, customers should provide adequate design and operating safeguards.

TI does not warrant or represent that any license, either express or implied, is granted under any TI patent right, copyright, mask work right, or other TI intellectual property right relating to any combination, machine, or process in which TI products or services are used. Information published by TI regarding third-party products or services does not constitute a license from TI to use such products or services or a warranty or endorsement thereof. Use of such information may require a license from a third party under the patents or other intellectual property of the third party, or a license from TI under the patents or other intellectual property of TI.

Reproduction of TI information in TI data books or data sheets is permissible only if reproduction is without alteration and is accompanied by all associated warranties, conditions, limitations, and notices. Reproduction of this information with alteration is an unfair and deceptive business practice. TI is not responsible or liable for such altered documentation. Information of third parties may be subject to additional restrictions.

Resale of TI products or services with statements different from or beyond the parameters stated by TI for that product or service voids all express and any implied warranties for the associated TI product or service and is an unfair and deceptive business practice. TI is not responsible or liable for any such statements.

TI products are not authorized for use in safety-critical applications (such as life support) where a failure of the TI product would reasonably be expected to cause severe personal injury or death, unless officers of the parties have executed an agreement specifically governing such use. Buyers represent that they have all necessary expertise in the safety and regulatory ramifications of their applications, and acknowledge and agree that they are solely responsible for all legal, regulatory and safety-related requirements concerning their products and any use of TI products in such safety-critical applications, notwithstanding any applications-related information or support that may be provided by TI. Further, Buyers must fully indemnify TI and its representatives against any damages arising out of the use of TI products in such safety-critical applications.

TI products are neither designed nor intended for use in military/aerospace applications or environments unless the TI products are specifically designated by TI as military-grade or "enhanced plastic." Only products designated by TI as military-grade meet military specifications. Buyers acknowledge and agree that any such use of TI products which TI has not designated as military-grade is solely at the Buyer's risk, and that they are solely responsible for compliance with all legal and regulatory requirements in connection with such use.

TI products are neither designed nor intended for use in automotive applications or environments unless the specific TI products are designated by TI as compliant with ISO/TS 16949 requirements. Buyers acknowledge and agree that, if they use any non-designated products in automotive applications, TI will not be responsible for any failure to meet such requirements.

Following are URLs where you can obtain information on other Texas Instruments products and application solutions:

<b>Products</b>		<b>Applications</b>	
Amplifiers	<a href="http://amplifier.ti.com">amplifier.ti.com</a>	Audio	<a href="http://www.ti.com/audio">www.ti.com/audio</a>
Data Converters	<a href="http://dataconverter.ti.com">dataconverter.ti.com</a>	Automotive	<a href="http://www.ti.com/automotive">www.ti.com/automotive</a>
DSP	<a href="http://dsp.ti.com">dsp.ti.com</a>	Broadband	<a href="http://www.ti.com/broadband">www.ti.com/broadband</a>
Interface	<a href="http://interface.ti.com">interface.ti.com</a>	Digital Control	<a href="http://www.ti.com/digitalcontrol">www.ti.com/digitalcontrol</a>
Logic	<a href="http://logic.ti.com">logic.ti.com</a>	Military	<a href="http://www.ti.com/military">www.ti.com/military</a>
Power Mgmt	<a href="http://power.ti.com">power.ti.com</a>	Optical Networking	<a href="http://www.ti.com/opticalnetwork">www.ti.com/opticalnetwork</a>
Microcontrollers	<a href="http://microcontroller.ti.com">microcontroller.ti.com</a>	Security	<a href="http://www.ti.com/security">www.ti.com/security</a>
RFID	<a href="http://www.ti-rfid.com">www.ti-rfid.com</a>	Telephony	<a href="http://www.ti.com/telephony">www.ti.com/telephony</a>
Low Power Wireless	<a href="http://www.ti.com/lpw">www.ti.com/lpw</a>	Video & Imaging	<a href="http://www.ti.com/video">www.ti.com/video</a>
		Wireless	<a href="http://www.ti.com/wireless">www.ti.com/wireless</a>

Mailing Address: Texas Instruments, Post Office Box 655303, Dallas, Texas 75265  
Copyright © 2007, Texas Instruments Incorporated