

PN5190

NFC frontend

Rev. 3.0 — 21 April 2021
662230

Product data sheet
COMPANY PUBLIC

1 General description

This document describes the functionality and electrical specification of the high-power NFC-IC PN5190B1, silicon version B1, using firmware or V2.0 or higher.

Additional documents supporting a design-in of the PN5190B1 are available from NXP, this additional design-in information is not part of this document.

The PN5190B1 supports highly innovative and unique features which do not require any host controller interaction. These features include dynamic power control (DPC), adaptive waveform control (AWC), and fully automatic EMD error handling.

The independence of real-time host controller interactions makes this product a good fit for systems which operate a pre-emptive multitasking OS like Linux or Android.

In this document, the term „MIFARE card“ refers to a contactless card using an IC out of the MIFARE Classic, MIFARE Plus, MIFARE Ultralight or MIFARE DESFire product family.



2 Features and benefits

2.1 RF functionality

- As a highly integrated high performance full NFC Forum-compliant frontend IC for contactless communication at 13.56 MHz, this NFC frontend IC utilizes an outstanding modulation and demodulation concept completely integrated for relevant 13.56 MHz based contactless communication methods and protocols.

PN5190B1 supports communication with all products of the MIFARE product-based card family including MIFARE Ultralight, MIFARE Classic 1K/4K, MIFARE DESFire EV1/EV2 and MIFARE Plus cards CRYPTO implemented in hardware for R/W of all NXP MIFARE product-based cards (includes intellectual-property licensing rights for NXP ISO/IEC 14443-A, Innovatron ISO/IEC 14443-B, and NXP MIFARE products). The PN5190B1 frontend IC supports the following RF operating modes:

2.1.1 ISO/IEC14443-A

- Reader/writer mode supporting ISO/IEC 14443-A R/W up to 848 kBit/s

2.1.2 ISO/IEC14443-B

- Reader/writer mode supporting ISO/IEC 14443-B up to 848 kBit/s

2.1.3 FeliCa

- Reader/writer mode supporting FeliCa 212 kBit/s and 424 kBit/s(without crypto)

2.1.4 Tag type reading

- Supports reading of all NFC tag types (type 1, type 2, type 3, type 4A and type 4B, type 5)

2.1.5 MIFARE card reading

- Reader/writer communication mode for the MIFARE card family including MIFARE Classic

2.1.6 ISO/IEC 15693

- Reader/writer mode supporting ISO/IEC 15693 (ICODE)
- Proprietary data rates based on ISO/IEC15693 with 106 kbit and 212 kbit/s (for NXP NTAG 5 communication)

2.1.7 Peer to peer

- P2P Active 106 kbit/s TO 424 kbit/s, Initiator and Target
- P2P Active 106 kbit/s TO 424 kbit/s, Initiator and Target
- Proprietary passive communication for type A up to 848 kbit/s
- Functionality according to ISO/IEC 21481 (NFC-IP-2)

2.2 Host interface

- One host interface based on SPI is implemented:
 - SPI interface with data rates up to 15 Mbit/s with MOSI, MISO, NSS and SCK signals
 - Interrupt request line to inform host controller on events
 - Independent TX and RX buffer for RF data with size of 1024 bytes each

3 Applications

- Payment
- Physical access
- eGov

4 Firmware versions

Firmware versions covered by this data sheet:

Version 2.0:

- This version cannot be replaced by FW versions using smaller version numbers (e.g. replacing FW2.0 by FW1.9 is not possible)
- This FW version is not available on volume production devices, but can be installed by the user

Before using this firmware in Peer to Peer target mode, for better communication stability the EEPROM address 0x292 (default A6E813C0) shall be initialized with the value (A6E813C1 - 0x292:0xC1 0x203: 0x13 0x294:0xE8 0x295:0xA6). This setting has no influence on reader or card emulation modes.

Version 2.1:

- This version is functionally equivalent to Version FW2.0 but offers updated EEPROM Settings compared to FW2.0
- This version cannot be replaced by FW versions using smaller version numbers (e.g. replacing FW2.1 by FW1.9 is not possible)
- This FW version is installed by default on volume production devices of PN5190 B1
- This FW and all upcoming FW versions will use the EEPROM Setting at address 0x292 = A6E813C1 to configure the Peer to Peer target mode for better communication stability.

5 Quick reference data

Table 1. Quick reference data

Symbol	Parameter	Conditions	Min	Typ	Max	Unit
$VDD_{(VBAT)}$	supply voltage on pin VBAT (analog and digital supply)	$VBAT \geq VDDIO$	2.4	-	5.5	V
$VDD_{(VDDIO)}$	supply voltage on pin VDDIO (supply for host interface and GPIO's)	1.8 V supply	1.62	-	1.98	V
		3.3 V supply	2.4	-	3.6	V
I_{pd}	power-down current	$VDD_{(VDDPA)} = VDD_{(VDDIO)} = VDD_{(VDD)} = 3.0$ V; hard power-down state; pin VEN set LOW, $T_{amb} = 25$ °C, External supply by VDDIO	-	40	105	μ A
I_{stb}	standby current	$T_{amb} = 25$ °C	-	45	110	μ A
I_{ULPCD}	average ultra-low-power card detection current	$T_{amb} = 25$ °C, $VDD_{(VDDPA)} = VDD_{(VDDIO)} = VDD_{(VDD)} = 3.0$ V, 330 ms Polling interval, 50 R antenna matching	-	22	-	μ A
$IDD_{(VDDPA)}$	supply current on pin VDDPA	supplied via VUP_TX (TX_LDO active)	-	-	350	mA
		supplied without DC-DC and TXLDO active	-	-	400	mA
$P_{(PA)}$	Transmitter output power	supplied via VUP_TX (TX_LDO active)	-	-	2.0	W
		supplied without DC-DC and TXLDO active	-	-	2.3	W
T_{amb}	ambient operating temperature	in still air with exposed pins soldered on a 4 layer JEDEC PCB,	-40	-	+85	°C
		in still air with exposed pins soldered on a 4 layer JEDEC PCB, HVQFN40 Package TX current = 120 mA @ $VDDPA=3.6$ V	-40	-	+105	°C
T_{stg}	storage temperature	no supply voltage applied	-55	-	+150	°C
T_{j_max}	maximum junction temperature	-	-	-	+125	°C

6 Ordering information

Table 2. Ordering information

Type number	Package		Version
	Name	Description	
PN5190B1HN/C121Y	HVQFN40R	Plastic thermal enhanced very thin quad flat package; no leads; 40 terminals + 1 central ground; body 5 x 5 x 1.0 mm; delivered in one reel, MSL=3. Minimum order quantity = 6000 pcs The ending Y in the product name is indicating the packing "reel" Initialized with FW 2.1	SOT2062-1
PN5190B1HN/C121E	HVQFN40R	Plastic thermal enhanced very thin quad flat package; no leads; 40 terminals + 1 central ground; body 5 x 5 x 1.0 mm; delivered in one tray, bakeable, MSL=3. Minimum order quantity = 490 pcs The ending E in the product name is indicating the packing "single tray" Initialized with FW 2.1	SOT2062-1
PN5190B1EV/C121Y	VFBGA64	Plastic thin fine-pitch ball grid array package; 64 balls, body 4.5 x 4.5 x 0.9 mm, delivered on reel 13", MSL = 3. Minimum order quantity = 4000 pcs The ending Y in the product name is indicating the packing "reel" Initialized with FW 2.1	SOT1307-2
PN5190B1EV/C121E	VFBGA64	Plastic thin fine-pitch ball grid array package; 64 balls, body 4.5 x 4.5 x 0.9 mm, delivered in one tray, MSL = 3. Minimum order quantity = 490 pcs The ending E in the product name is indicating the packing "single tray" Initialized with FW 2.1	SOT1307-2

7 Block diagram with VFBGA64 connections

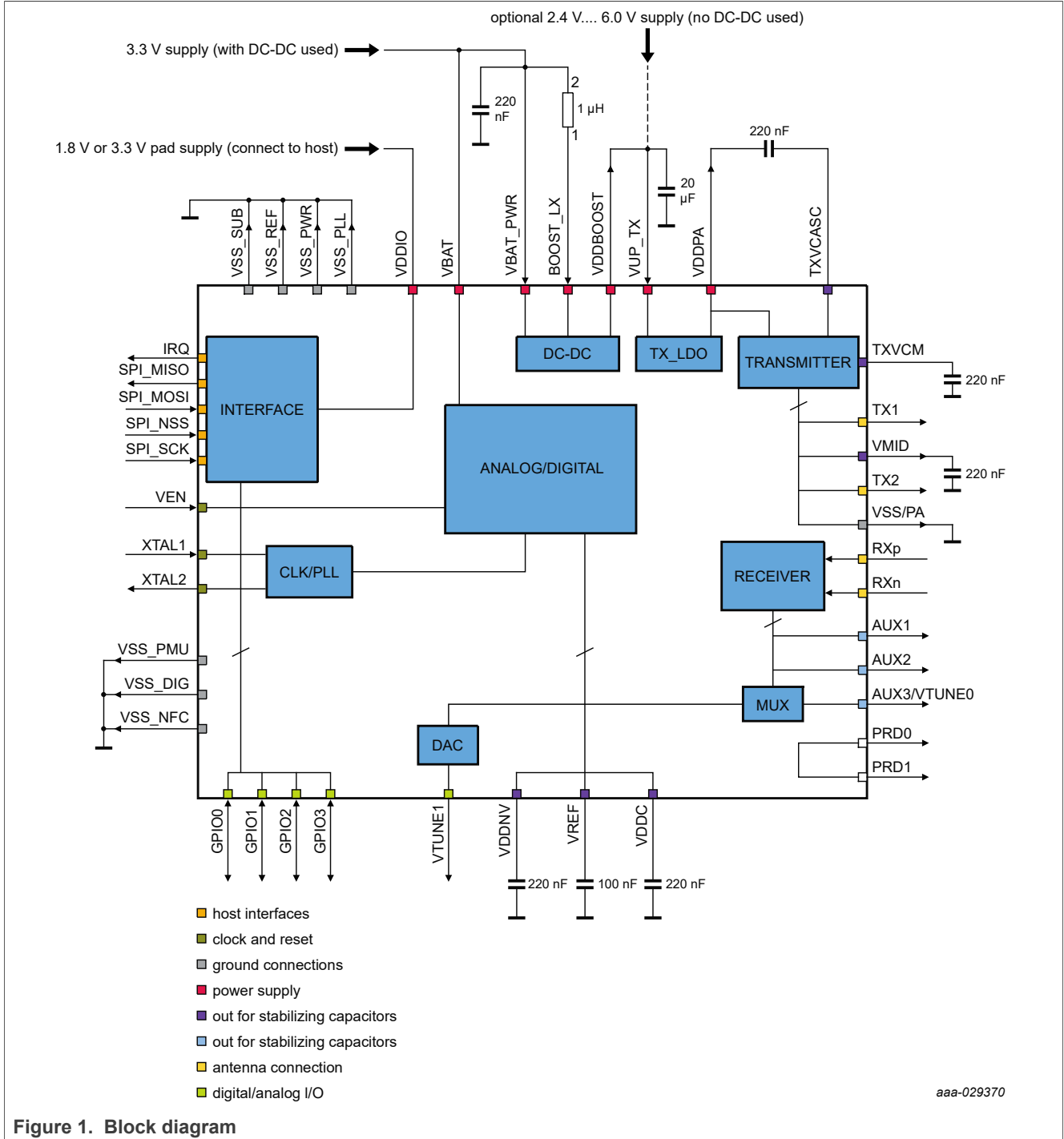

Figure 1. Block diagram

8 Pinning information

8.1 Pin description VFBGA64

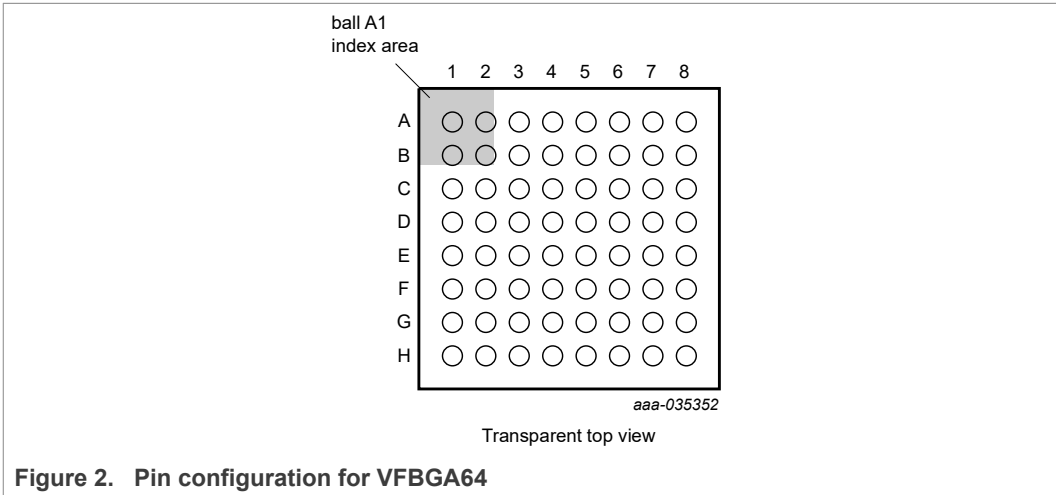

Figure 2. Pin configuration for VFBGA64

Table 3. Pin description VFBGA64

Pin Number	Symbol	Type	Description PN5190	Description PN76 family (planned pinning of upcoming device)
Host Interface				
E6	ATX_A	Output	SPI slave data output	UART RX / I ³ C SDA / SPI MISO / I ² C SDA
E5	ATX_B	Input	SPI clock input	UART CTS / I ³ C SCL / SPI SCK / I ² C SCL
D6	ATX_C	Input	SPI slave select input	UART RTS / I ³ C Adr Bit 0 / SPI NSS / I ² C Adr Bit 0 / USB D+
D5	ATX_D	Input	SPI slave data input	UART TX / I ³ C Adr Bit 1 / SPI MOSI / I ² C Adr Bit 1 / USB D-
B7	IRQ	Output	Host communication/ event interrupt signal	Host communication / event interrupt signal
F8	XTAL1	Input	Crystal / system clock input	Crystal / system clock input
G8	XTAL2	Output	Clock output (amplifier inverted signal output) for crystal	Clock output (amplifier inverted signal output) for crystal
B3	VEN	Input	Hardware reset, low active (independent from V _{VDDIO})	Hardware reset, low active (independent from V _{VDDIO})
Supply pins				
H2	VSS_PA	Supply GND	Transmitter ground	Transmitter ground
G3	VSS_PLL	Supply GND	PLL ground (low noise)	PLL ground (low noise)
A2	VSS_PWR	Supply GND	DC-DC boost ground	DC-DC boost ground

Table 3. Pin description VFBGA64...continued

Pin Number	Symbol	Type	Description PN5190	Description PN76 family (planned pinning of upcoming device)
D3	VSS_REF	Supply GND	PMU ground	PMU ground
B2, E3	VSS_SUB	Supply GND	Substrate ground	Substrate ground
C3	VSS_PMU	Supply GND	PMU ground	PMU ground
F4	VSS_DIG	Supply GND	Digital ground	Digital ground
F3	VSS_NFC	Supply GND	NFC ground	NFC ground
E1	VBAT	Supply	System supply, used to supply the analog and digital blocks, memory and internal voltage references	System supply, used to supply the analog and digital blocks, memory and internal voltage references
A8	VDDIO	Supply	IO pads power supply	IO pads power supply
G1	VDDPA	Supply	Transmitter supply	Transmitter supply
F1	VUP_TX	Supply	Input supply voltage for transmitter LDO	Input supply voltage for transmitter LDO
B1	VDDBOOST	Supply	DC-DC boost supply	DC-DC boost supply
A1	BOOST_LX	Output	Boost inductance loopback, to be connected to boost inductor	Boost inductance loopback, to be connected to boost inductor
A3	VBATPWR	Supply	To be connected to boost inductor and transmitter power supply	To be connected to boost inductor and transmitter power supply
Outputs for stabilizing cap				
A4	VDDNV	Output	Non-volatile memory power supply, to be connected to ground via 220 nF blocking cap	Non-volatile memory power supply, to be connected to ground via 220 nF blocking cap
D2	VREF	Output	High quiescent reference voltage, to be connected to ground via 100 nF blocking cap	High quiescent reference voltage, to be connected to ground via 100 nF blocking cap
C1	VDDC	Output	Power supply for Digital Core, to be connected to ground via 220 nF blocking cap	Power supply for Digital Core, to be connected to ground via 220 nF blocking cap
G2	TXVCM	Output	Transmitter voltage common mode, to be connected to ground via 220 nF blocking cap	Transmitter voltage common mode, to be connected to ground via 220 nF blocking cap
F2	TXVCASC	Output	TX decoupling cap, to be connected to VDDPA	TX decoupling cap, to be connected to VDDPA
H6	VMID	Output	Stabilizing capacitor connection output, to be connected to electrical symmetry point of antenna (typically antenna ground) by 100 nF blocking cap	Stabilizing capacitor connection output, to be connected to electrical symmetry point of antenna (typically antenna ground) by 100 nF blocking cap
RF Debug signals				
G7	AUX_1	Output	Test bus 1	Test bus 1
F7	AUX_2	Output	Test bus 2	Test bus 2

Table 3. Pin description VFBGA64...continued

Pin Number	Symbol	Type	Description PN5190	Description PN76 family (planned pinning of upcoming device)
H8	AUX_3 / VTUNE0	Output	Test bus 3 / VTUNE0 (Digital to analog output 0)	Test bus 3 / VTUNE0 (Digital to analog output 0)
Antenna connections				
H5	RXP	Input	Receiver input "Positive"	Receiver input "Positive"
H4	RXN	Input	Receiver input "Negative"	Receiver input "Negative"
H1	TX1	Output	Antenna driver output 1	Antenna driver output 1
H3	TX2	Output	Antenna driver output 2	Antenna driver output 2
Analog/Digital inputs & outputs				
H7	VTUNE1	Output	Digital to analog output 1 (not available on HVQFN40)	Digital to analog output 1 (DAC 1)
E8	GPIO0	Input/Output	General Purpose In/Out 0	General Purpose I/O 0
D8	GPIO1	Input/Output	General Purpose Output 1	General Purpose I/O 1
E7	GPIO2	Input/Output	General Purpose Output 2	General Purpose I/O 2
D7	GPIO3	Input/Output	General Purpose Output 3 If PN5190 is using the ULPCD, GPIO3 cannot be used for any other purpose than aborting the ULPCD.	General Purpose I/O 3 If PN76 is using the ULPCD, GPIO3 cannot be used for any other purpose than aborting the ULPCD.
Security Feature				
B4	PRD1	Input/Output	Package removal detection, internally connected to PRD2 (not available on HVQFN40)	Package removal detection, internally connected to PRD2
G4	PRD2	Input/Output	Package removal detection, internally connected to PRD1 (not available on HVQFN40)	Package removal detection, internally connected to PRD1
Pins connected on PN76 family only				
A5	PVDD_OUT	Output	PN5190: Do not connect	PVDD LDO output
A6	I2CM_SDA	Input/Output	Do not connect	I ² C master SDA
A7	DWL_REQ	Input	Do not connect	Download request (optional)
B5	GPIO5	Input/Output	Do not connect	General Purpose I/O 5
B6	I2CM_SCL	Input	Do not connect	I ² C master SCL
B8	SWDIO	Input/Output	Do not connect	Single Wire Debug Interface Data
C2	TEST	Input/Output	Internal test pin. Do not connect	Internal test pin. Do not connect.
C4	ISO_INT_AUX	Input/Output	Do not connect	Auxiliary Card Interrupt

Table 3. Pin description VFBGA64...continued

Pin Number	Symbol	Type	Description PN5190	Description PN76 family (planned pinning of upcoming device)
C5	GPIO4	Input/Output	Do not connect	General Purpose I/O 5
C6	HOST_IF_SEL1	Input	Do not connect	Host interface select 1
C7	HOST_IF_SEL0	Input	Do not connect	Host interface select 0
C8	SWD_CLK	Input	Do not connect	Single Wire Debug Interface Clock
D1	USB_VBUS	Supply	Do not connect	USB VBUS supply
D4	ISO_IO_AUX	Input/Output	Do not connect	Auxiliary Card I/O
E2	AD1	Input	Do not connect	Analog/Digital Converter Input 1
E4	ISO_CLK_AUX	Input	Do not connect	Auxiliary Card Clock
F5	SPIM_MOSI	Input	Do not connect	SPI master MOSI
F6	SPIM_MISO	Output	Do not connect	SPI master MISO
G5	SPIM_SCLK	Input	Do not connect	SPI master clock
G6	SPIM_NSS	Input	Do not connect	SPI master NSS

For good RF performance, all blocking capacitors shall be placed on the same side of the PCB, traces from pin to capacitor shall be as short as possible.

All Supply GND connections shall be connected by low-ohmic connections on the PCB.

PN76 is a planned product, the pin allocation is provided for information only. This product PN76 will assign functionality to n.c. pins of the PN5190.

8.2 Pin description HVQFN40

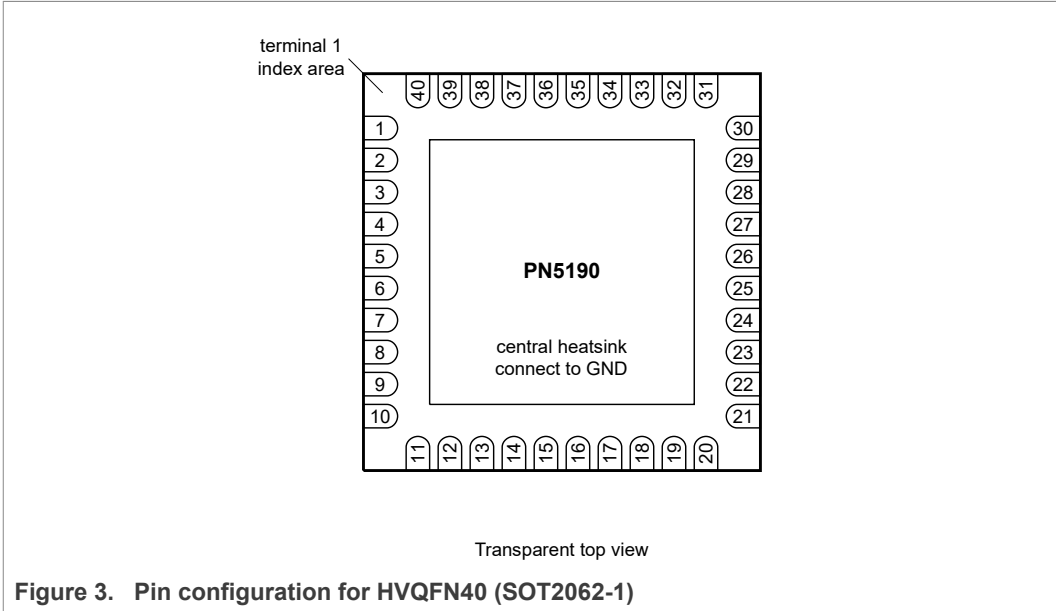

Table 4. Pin description HVQFN40

Pin Number	Symbol	Type	Description PN5190
1	BOOST_LX	Output	Boost inductance loopback, to be connected to boost inductor pin 1
2	VDDBOOST	Supply	Boosted supply voltage output
3	VSS_REF	Supply GND	PMU ground
4	VREF	Output	High quiescent reference voltage, to be connected to ground via 100 nF blocking cap
5	VBAT	Supply	System supply, used to supply the analog and digital blocks, memory and internal voltage references
6	VUP_TX	Supply	Input supply voltage for transmitter LDO
7	TXVCASC	Output	TX decoupling cap, to be connected to VDDPA
8	VSS	Supply GND	Ground
9	VDDPA	Supply	Transmitter supply
10	TXVCM	Output	Transmitter voltage common mode, to be connected to ground via 220 nF blocking cap
11	TX1	Output	Antenna driver output 1
12	VSS_PA	Supply GND	Transmitter ground
13	TX2	Output	Antenna driver output 2
14	RXN	Input	Receiver Input "Negative"
15	RXP	Input	Receiver input "Positive"
16	VMID	Output	Stabilizing capacitor connection output, to be connected to electrical symmetry point of antenna (typically antenna ground)

Table 4. Pin description HVQFN40...continued

Pin Number	Symbol	Type	Description PN5190
17	VSS	Supply GND	Ground
18	XTAL1	Input	Crystal / System clock input
19	XTAL2	Output	Clock output (amplifier inverted signal output) for crystal
20	VTUNE1	Output	Digital to analog output 0
21	AUX_1	Output	Test bus 1
22	AUX_2	Output	Test bus 2
23	AUX_3 / VTUNE0	Output	Test bus 3 / VTUNE0 Digital to analog output 1
24	ATX_A	Input	SPI slave data output
25	ATX_B	Input	SPI clock input
26	ATX_C	Output	SPI slave select input
27	ATX_D	Input	SPI slave data input
28	IRQ	Output	Host communication/ event Interrupt signal
29	VDDIO	Supply	IO pads power supply
30	GPIO3	Output	General Purpose Out 3
31	GPIO2	Output	General Purpose Out 2
32	GPIO1	Output	General Purpose Out 1
33	GPIO0	Output	General Purpose Out 0
34	n.c.	-	-
35	VSS	Supply GND	Ground
36	VDDC	Output	Power supply for Digital Core, to be connected to ground via 220 nF blocking cap
37	VEN	Input	Hardware reset, low active (independent from V_{PVD})
38	VDDNV	Output	Non-volatile memory power supply, to be connected to ground via 220 nF blocking cap
39	VBATPWR	Supply	To be connected to boost inductor pin 2 and transmitter power supply
40	VSS_PWR	Supply GND	DC-DC boost ground

For best performance, all blocking capacitors shall be placed on the same side of the PCB, traces from pin to capacitor shall be as short as possible.

Compared to the BGA package, all ground connections named VSS are connected on the leadframe of the package. Therefore general VSS pins do exist, pins are not distinguished by function like on the BGA package type e.g. VSS_PMU. The exceptions are the pins VSS_PWR, VSS_PA and VSS_REF.

All Supply GND connections shall be connected by low-ohmic connections on the PCB.

9 Functional description

9.1 Functional overview

The PN5190B1 is an NFC frontend with high transmitter output power. It implements the RF functionality like an antenna driving and receiver circuitry and all the low-level functionality to realize an NFC Forum and EMVCo compliant reader.

Connection to host controller

The PN5190B1 connects to a host microcontroller with a fast SPI interface (15 Mbit/s) for configuration, NFC data exchange and high-level NFC protocol implementation. An optimized TLV-based framing is supported to reduce the command handling overhead on the host controller and to reduce command-response latencies. Multiple commands are allowed to be sent within a single frame and processed in sequential order. This reduces the handshake overhead for a transaction significantly and by this shortens the overall time of a transaction.

Clock supply

The PN5190B1 uses an external 27.12 MHz crystal as clock source for generating the RF field and its internal digital logic. Alternatively, an internal PLL allows using an accurate external clock source of either 24 MHz, 32 MHz and 48 MHz (configured in EEPROM register CLK_INPUT_FREQ, 0012h)). This allows saving the 27.12 MHz crystal in systems which implement one of the mentioned clock frequencies.

Integrated DC-DC

The integrated DC-DC allows a single supply voltage while delivering maximum RF output power. Dependent on the application target either a direct transmitter supply or a transmitter supply by the integrated DC-DC can be chosen. The usage of the integrated DC-DC is the preferred choice for a stable RF performance, even in case of a de-charged battery. Optimized usage of a battery charge can be achieved by directly connecting the transmitters to the supply. The DC-DC is controlled by the Dynamic Power Control 2.0 to keep the power dissipation of the chip minimized in antenna loading cases which require a reduction of the RF output power.

The DC-DC is a step-up converter and is able to deliver an output voltage from approx. 2.8 V up to 6.0 V. The targeted output voltage can be configured by software.

The DC-DC clock is synchronized with the clock of the receiver - this avoids the typical performance reduction by DC-DC noise which can be seen in systems using external DC-DCs.

Transmitter LDO (VDDPALDO)

The Transmitter output drivers are supplied by a transmitter LDO which reduces external noise and is used for the DPC functionality to lower the supply voltage of the transmitters. The high granularity of 100 mV for setting the VDDPALDO output voltage together with a sophisticated control loop and true current measurement ensures that a DPC regulation is not accidentally treated as received data.

Low-power card detection

The low-power card detection (LPCD) allows saving battery charge during polling for NFC counterparts like cards and mobile phones. In general, the low-power card detection provides a functionality, which allows to power down the reader for a certain amount of time to save energy. After some time, the reader becomes active again to poll for cards. If

no card is detected, the reader can go back to the power down state. During the polling time, a host controller can be set to a power-saving mode. An interrupt request from the PN5190B1 allows waking up the host controller in case an antenna detuning by a card or cell phone had been detected.

Two modes for the low-power card detection are available:

- LPCD (software based) which allows maximum detection range. For detecting a card presence, I/Q channel information is used.
- ULPCD (hardware based) which offers maximum current savings. For detecting a card presence, only the amplitude information is used.

Dynamic power control 2.0

The next generation Dynamic Power Control (DPC2.0) with true transmitter current measurement works autonomous without host interaction. Avoiding additional host controller processing load is important for time critical applications like payment. A fast control response time of less than 1 ms allows using optimized antenna matchings.

Adaptive wave shape control

The Adaptive Wave Shape Control (AWC) helps to keep the waveshapes within specification limits, even in case of antenna detuning. This simplifies the time-consuming antenna matching procedure and does not require any matching compromises to be taken.

Receiver signal level control

The receiver signal chain consists of an automatic controller RF input attenuator and a true Baseband Amplifier (BBA). This feature delivers an outstanding communication range with tags, labels, cards and mobile phones.

RF Debugging

Comprehensive and innovative debug features are implemented to support the NFC reader development even for difficult and non-standard compliant cards and mobile phones. An Integrated Chip scope allows performing a non-intrusive debugging of receiver signals without the need of connecting additional wires to the chip. Capturing of chip-internal signals is done by configuring flexible trigger conditions, sampled internal data is stored in RAM memory, transferred by SPI to a host microcontroller and visualized on a PC by the NFC Cockpit development tool. A virtual comfort interface (VCOM) is supported by the NFC cockpit tool, which allows to use the NFC cockpit together with any host microcontroller. Analog debug signals (AUX1, AUX2) are available as well and allow the connection of an Oscilloscope for analog and digital signal debugging.

The receiver signal processing is optimized to cope with noisy environments. This is beneficial, especially in case a TFT display or DC-DCs are part of the NFC system.

Automatic EMD error handling

An automatic EMD handling performed without host interaction relaxes the timing requirements on the Host Controller. Automatic EMD error handling according to ISO/IEC14443 and EMVCo 3.0 is supported. In addition, the EMD error handling is widely configurable, which allows adaptations in case of future possible specification changes.

Automatic antenna tuning

Two analog outputs are available to connect variable capacitors for automatic antenna tuning (AAT). The automatic antenna tuning allows compensating for production tolerances or changing environments like surrounding metal. This is especially beneficial

for applications which make use of OEM NFC Modules which are finally used in an unknown environment. The automatic antenna tuning is performed command triggered.

Firmware update

The PN5190B1 supports a secure update of the implemented firmware. The secure firmware download mode is using a dedicated command set, but a framing which is not different from the standard host interface commands used for NFC operation of the device. In Secure Firmware update mode, the PN5190B1 requires no dedicated physical handling of the SPI interface lines. The firmware download does not require any additional hardware pin to be handled, instead the download mode is activated by a command, followed by a hardware reset. After booting from reset, the PN5190B1 will be in download mode.

Register configuration

Internal registers of the PN5190B1 store volatile configuration data and accessible by the host interface. The internal registers are reset to configurable initial values in case of powerON, hardware-reset and standby.

The configuration for dedicated RF protocols and antenna-dependent configuration is defined in non-volatile memory. This configuration is typically done only once during production, and is performed by a command issued from the host microcontroller.

EEPROM configuration

Non-Volatile EEPROM memory of the PN5190B1 is used to store configuration data that needs to be preserved in case the PN5190B1 is not connected to any supply voltage. The configuration for dedicated RF protocols and antenna-dependent configuration is defined in this non-volatile memory and copied to volatile registers by a host interface command. In addition, other configuration data which needs to be preserved during power supply disconnect is stored in this EEPROM memory as well. Examples for this are configurations for DPC, LPCD and ULPCD configurations.

RF configuration

The PN5190B1 allows a fast RF protocol selection based on the command Load_RF_configuraton and pre-defined user configuration data in non-volatile memory (EEPROM).

On the one hand, the configuration of modulation-related parameters can be done (e.f. selection of ISO/IEC14443-A), on the other hand antenna-specific parameters can be configured.

For more information see [\[1\]](#).

9.2 Endianness

The endianness describes the order of bytes or bits within a binary representation of a value in the memory, which can be a register or EEPROM.

"Array size" defines the number of elements of "type size". Type size can be uint8 (8 bit), uint16 (16 bit) or uint32 (32 bit).

The location of byte sized data (8 bit) with an array size of 2 is as follows:

Value hex: 0x1234

address x: 12

address x+1: 34

The location of word sized data (16 bit) is as follows:

Value hex: 0x1234

address x: 34

address x+1: 12

The location of word sized data (16 bit) in an array size of 2 is as follows:

The placement of the array is large endian, the placement of nibbles of the variable is small endian.

Value hex: 0xAABBCCDD

address x: BB

address x+1: AA

address x+2: DD

address x+3: CC

The location of double word sized data (32 bit) is as follows:

Value hex: 0xAABBCCDD

address x: DD

address x+1: CC

address x+2: BB

address x+3: AA

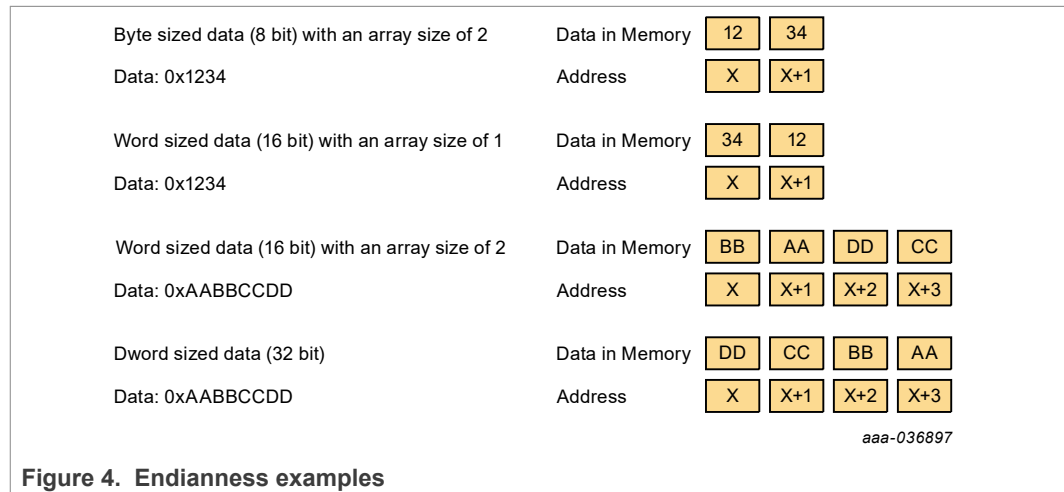

Data from the EEPROM is read in little endian format - LSB first. This means that the byte at the lower address is read first.

9.3 Initial calibration

The PN5190B1 requires a calibration before the RF field is switched on for the first time.

The calibration sequence is the following:

Write EEPROM CfgNovCal (0xC83) – 0x00

Write REGISTER TX_NOV_CALIBRATE_AND_STORE_VAL (addr: 0x5d) - 0x01

Write EEPROM CfgNovCal (0xC83) – 0x02

9.4 System power states

The PN5190B1 can operate in different power states. The functionality and current consumption is dependent on the actual system power state.

Power states can be changed by the level on the pin VEN and by connecting/disconnecting the power supply of VBAT.

In addition, state changes are triggered possible by host commands.

Disconnecting and connecting the power supply on VBAT restarts the PN5190B1 always in Active State after releasing the pin VEN (transition low to high).

A transition of low to high on pin VEN restarts the PN5190B1 always in Active State.

The following power states are supported:

Power state	Description	typical current consumption
Power OFF	The NFC system (supply pin VBAT, RF transmitter) is not supplied by a battery/system PMU. Other domains might be supplied (for example, IO pad interface on pin VDDIO). Device is not functional	-
PMU OFF	The NFC system is disabled by the host via a low signal on pin VEN. No internal clocks of the PN5190B1 are active. Wake-up events to change PMU OFF state: Power reset on pin VBAT, VEN rising edge, RX ULPCD detect, ULP abort signal on PIN3	5 µA
ULP standby	The host can set the PN5190B1 into Ultra-low power card detection state (ULP Standby state) via programming of the ULPCD bit. In the ULP Standby state, the PN5190B1 is able to activate the transmitter and receiver after defined time (expiry of wake-up timer) to detect the card. If a card is not detected, the transmitter and receiver is deactivated and the wake-up timer restarted. Power consumption of ULP Standby mode is much lower than Hard Power Down State and Standby State. Only the wake-up timer is active during ULP Standby state Wake-up events: Power reset on pin VBAT, VEN rising edge, Card detected. Variant 1: Configurable wake-up timer allows system to boot into active Variant 2: Configurable wake-up timer allows checking regularly for a card in the field.	Variant 1: 5 µA Variant2: 22 µA
Hard power down	The NFC system is disabled by the Host system via the reset/enable signal on VEN or by detecting an external condition (for example, battery voltage monitor). The power dissipation is reduced to a minimum. No power dissipation or leakage is expected on the different interfaces. Low-power resources are enabled (VDDC_LP, VHV_LP, LQ_REF, LQ-BIAS). LFO clock is available. PCRM is supplied and is running in low-power state. I/Os are supplied by VDDC_HP. Wake-up events: Power reset on pin VBAT, VEN rising edge, RX ULP detect	40 µA

Power state	Description	typical current consumption
Standby	The NFC system can switch after a specific time of inactivity automatically into a low-power mode to minimize power dissipation. The state of external interfaces is maintained properly. PMU operates in low-power state. Wake-up counter clock is available. PCRM is supplied and running in low-power mode. I/Os are supplied by VDDC_LP. PMU FSM in PCRM manages the transition in power state. Wake-up sources: Activity on host IF, SWPM communication, ULPDET, LPDET, wake-up counter, power loss on VDDIO, GPIO, RxPROT, No High Temp on TX and so on.	45 μ A
Suspend	All power sources are available. LFO and HFO clocks are available. CPU subsystem clock sources are gated, except for the LFO. I/O's are available.	2.5 mA
Active	The PN5190B1 is able to process internal or external events or data. All external power supply sources and the external clock need to be available, and all internal clocks are active.	20 mA (system without RF current)

9.5 Power supply

The device allows to configure different power supply options for the transmitter power amplifier. To make use of them, a combination of external connections and chip internal configurations needs to be done. The following supply options are available:

- Internal VDDPA configuration: The TX power amplifier is supplied by the internal voltage regulator (VDDPALDO). In this configuration the DPC, current measurement and overcurrent protection is available. In addition, the VDDPALDO is adding an improved rejection of noise on the supply lines.
- Direct VDDPA configuration: This configuration is recommended for applications which require highest efficiency, like battery supplied devices. In this configuration, a battery can be connected directly to the transmitter supply avoiding the voltage drop of approximately 0.3 V caused by the VDDPALDO. A clean supply voltage without noise is required to achieve a good RF performance.
In this configuration the DPC, current measurement and overcurrent protection is not available.

9.5.1 System power supply overview

The PN5190B1 is using three different supplies each for the following functional blocks:

1. Supply for the host interface and GPIO's (VDDIO)
2. Supply for the analog and digital blocks (VBAT/VBAT_PWR)
3. Supply of the RF drivers (VDDPA), DC-DC (VBAT_PWR) and VDDPALDO (VUP)

The functionality of the GPIO's, Host Interface and internal analog and digital blocks is independent from the supply of the RF Driver. This allows to configure a dedicated transmitter supply configuration at any time. Care shall be taken to switch on the RF field only after the transmitter-related power supply had been configured according to the external physical supply connections (VDDPA, VBAT_PWR, VUP).

The power supply configuration is configured in EEPROM and therefore will not get lost in case of power supply loss or reset of the chip. Typically, this configuration is only performed once during the production of a reader.

RF field shall not be turned on without setting the correct power supply configuration in the EEPROM.

Note: The Voltage on pin VDDIO must always be smaller or equal to the Voltage on pin VBAT.

9.5.2 Connecting blocking capacitors

Some pins are connected to blocking supply capacitors. PCB traces to these capacitors need to be as short as possible, and a low-ohmic grounding of the GND-side of the capacitors is required for optimized RF performance.

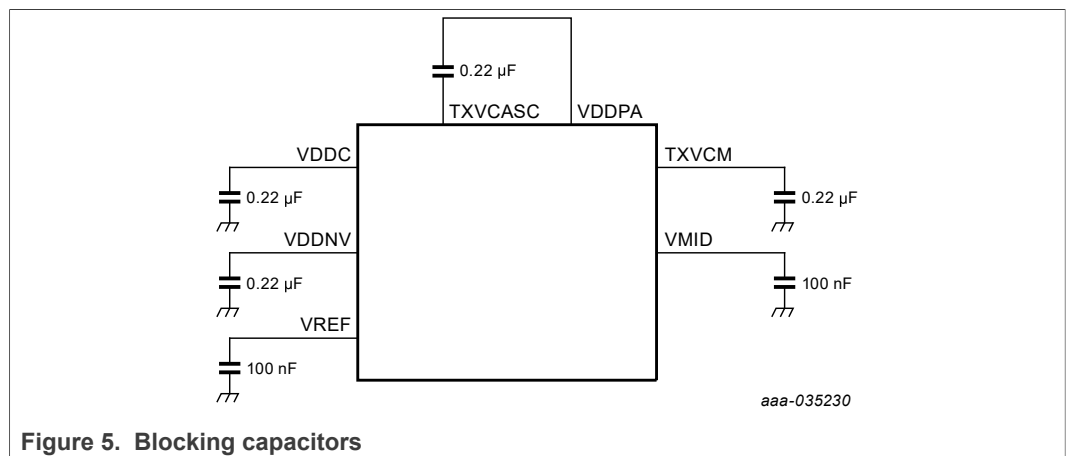

Figure 5. Blocking capacitors

9.5.3 Transmitter power supply

The PN5190B1 is configured by EEPROM for the different power supply options.

The following registers are used to configure the power supply of the transmitter:

DCDC_PWR_CONFIG (0004h) - Enables/disables and configures the DC-DC according to the external supply connections.

DCDC_DELAY_TO_ON (0008h) -

DCDC_DELAY_TO_OFF (0009h) -

VDDPALDO_CONFIG (address 000Ch) - Enables/disables and configures the TXPALDO.

VDDPALDO_VDDPA_HIGH (address 0010h) - out voltage when DC-DC or external power source is used as supply.

VDDPALDO_VDDPA_LOW (address 0011h) - out voltage when VBAT is used as supply.

VDDPALDO_VDDPA_MAX_RDR (address 0012h) - maximum voltage to be set in reader mode used by DPC.

VDDPALDO_VDDPA_MAX_CARD (address 0013h) - VDDPA maximum voltage to be set in card mode used by DPC.

No specific registers are required to configure the pad supply (VDDIO) or the supply for the analog and digital blocks (VUP).

9.5.3.1 VDDPALDO transmitter supply

VDDPALDO supplied VDDPA configuration: The TX power amplifier is supplied by the internal voltage regulator (VDDPALDO).

In this configuration the DPC, current measurement and overcurrent protection is available. In addition, the VDDPALDO is adding an improved rejection of noise on the supply lines.

A decoupling cap is required on VDDPA pin.

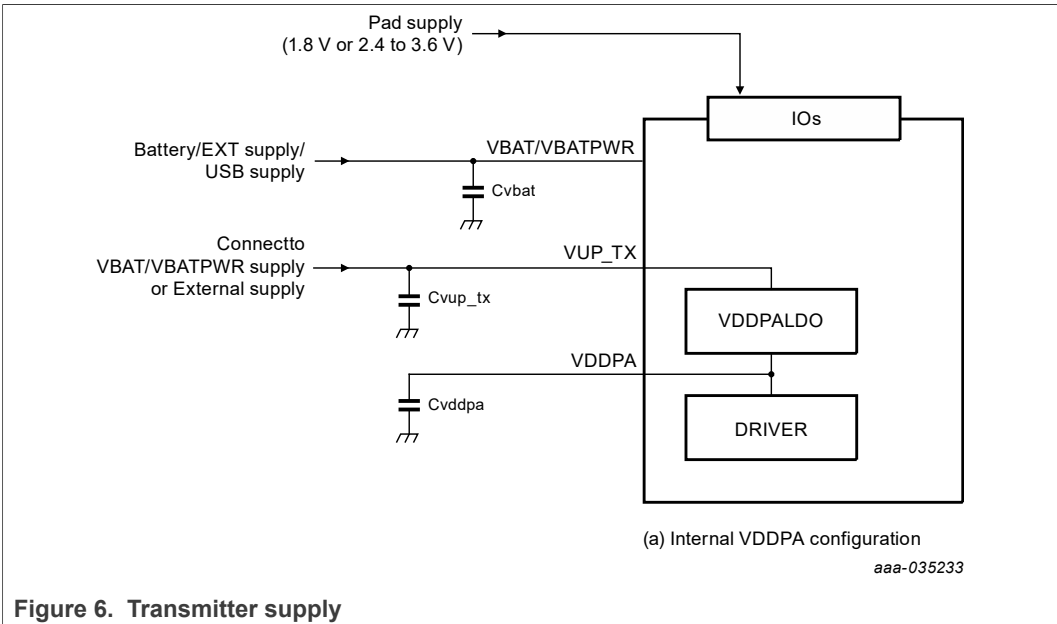

Figure 6. Transmitter supply

9.5.3.2 Direct transmitter supply

Direct VDDPA configuration:

VDDPALDO must be configured OFF by SW configuration. VUP_TX and VDDPA connected to VBAT/VBATPWR.

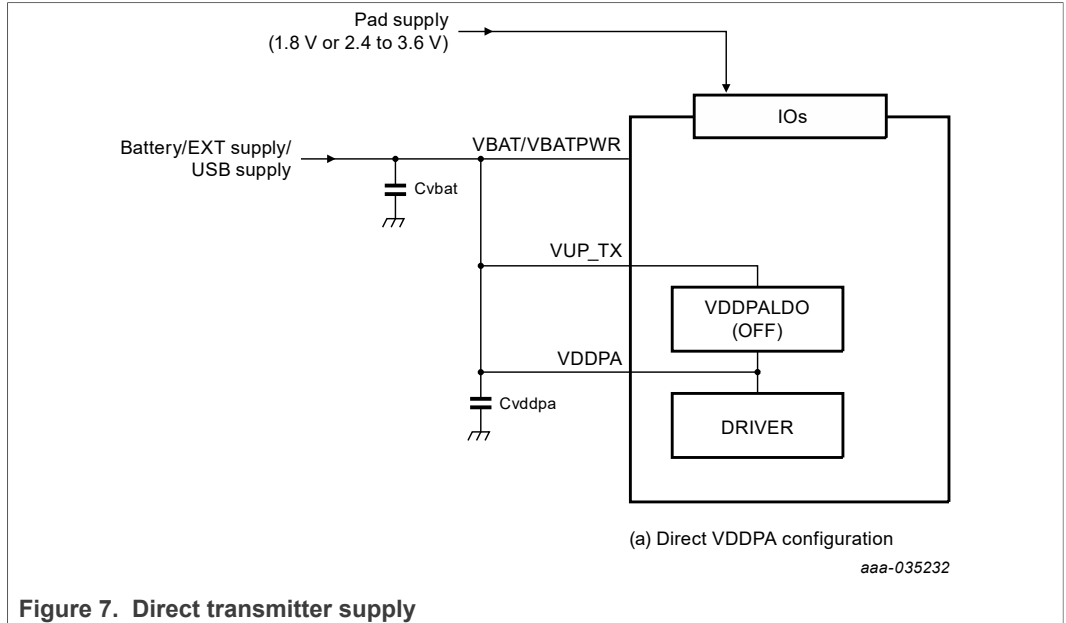

Figure 7. Direct transmitter supply

9.5.3.3 DC-DC (boost) supply

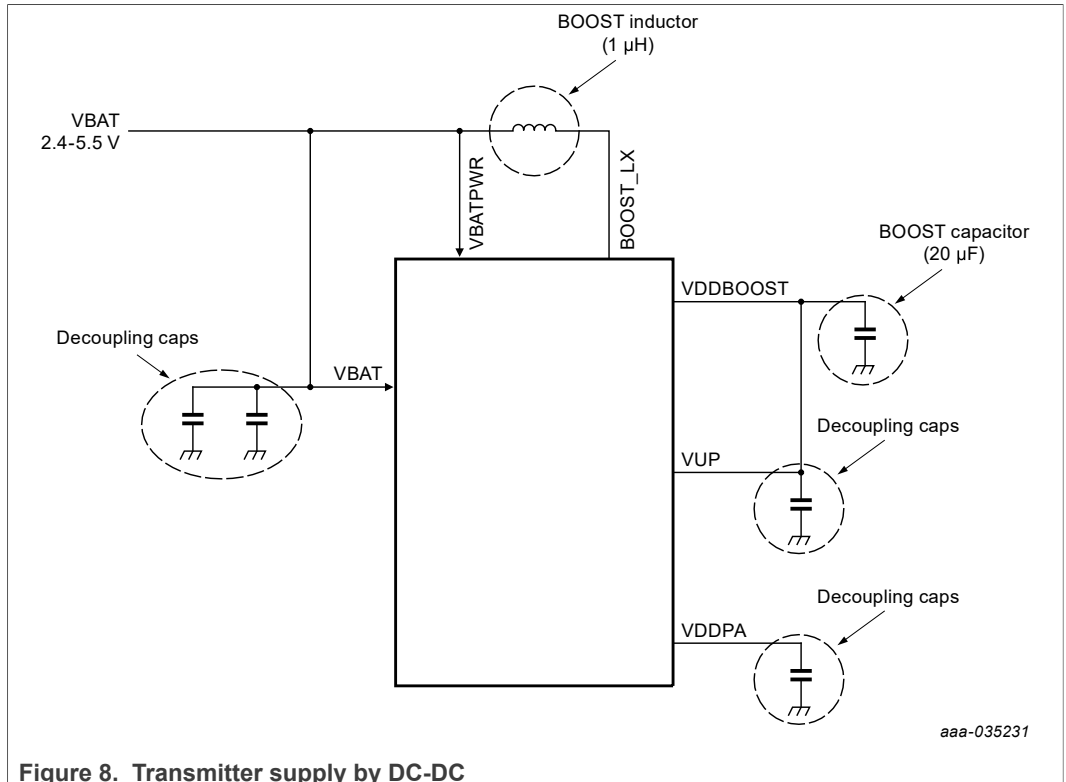

Figure 8. Transmitter supply by DC-DC

9.5.3.4 Configuration example 1: VDDPALDO transmitter supply - DC-DC active

VBAT is connected to VBATPWR.

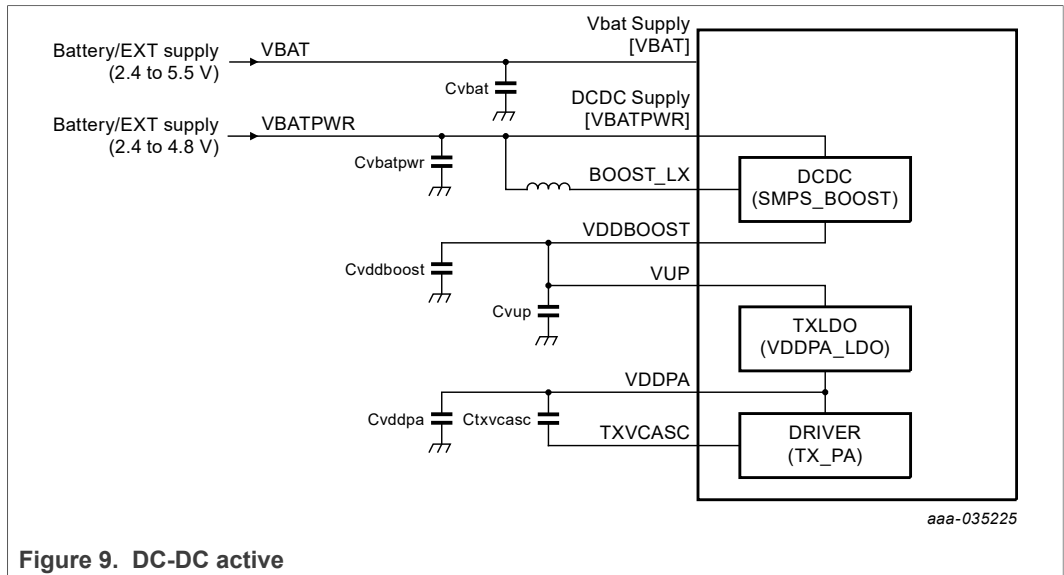

Figure 9. DC-DC active

9.5.3.5 Configuration example 2: VDDPALDO transmitter supply - DC-DC bypassed

VBAT is connected to VBATPWR.

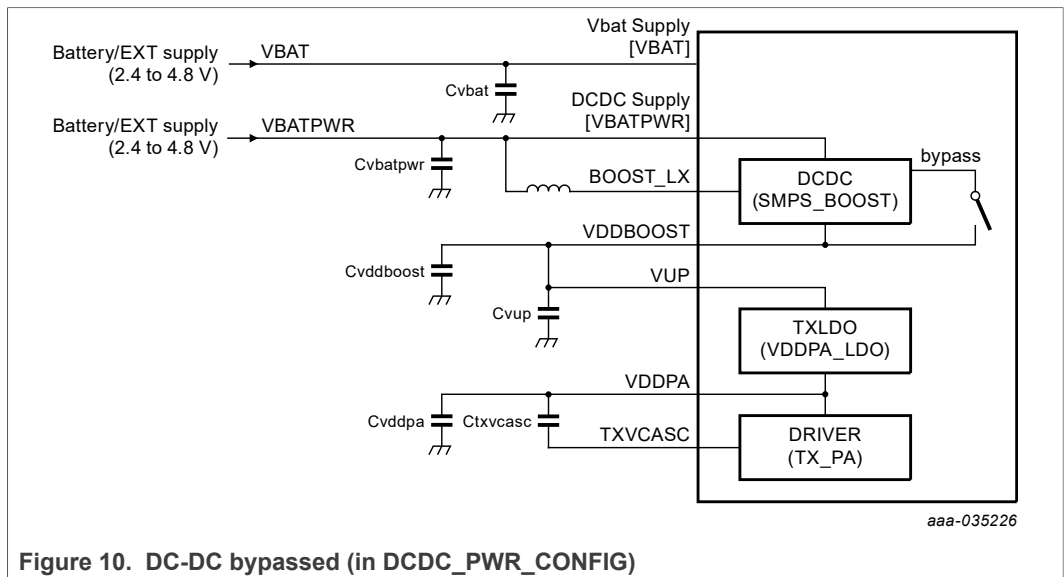
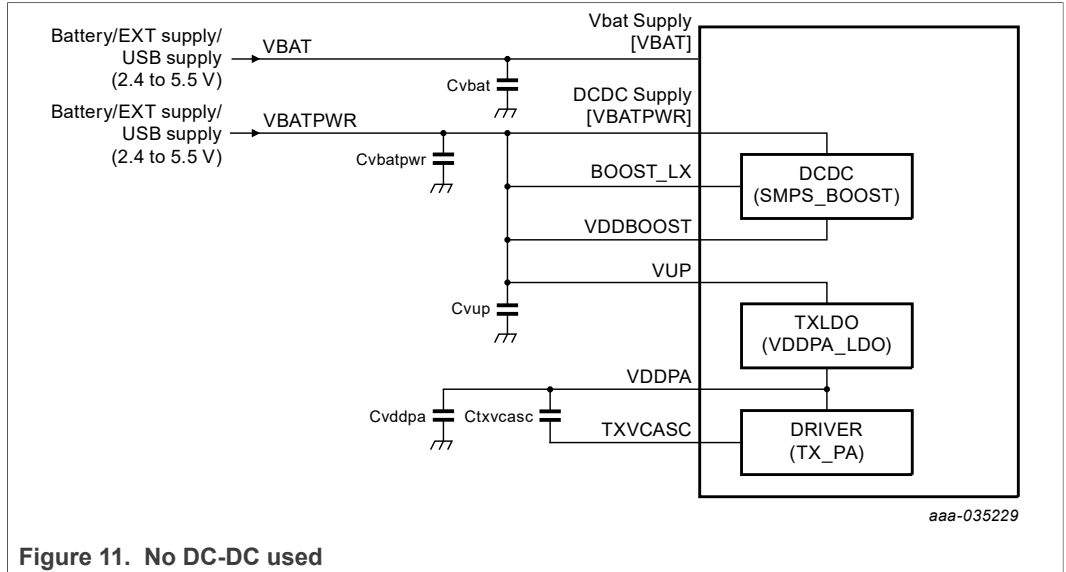

Figure 10. DC-DC bypassed (in DCDC_PWR_CONFIG)

9.5.3.6 Configuration example 3: VDDPALDO transmitter supply connected to VBAT - no DC-DC

VBAT is connected to VBATPWR.



9.5.3.7 Configuration example 4: VDDPALDO supplied independent from VBAT - no DC-DC

VBAT is connected to VBATPWR.

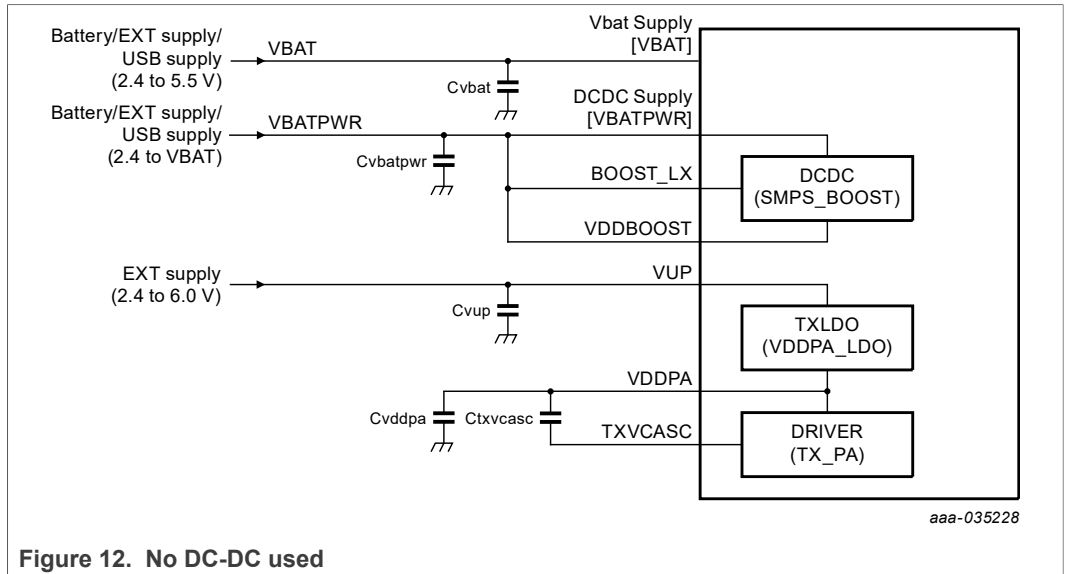

9.5.3.8 Configuration example 5: VDDPALDO not used - no DC-DC

VBAT is connected to VBATPWR.

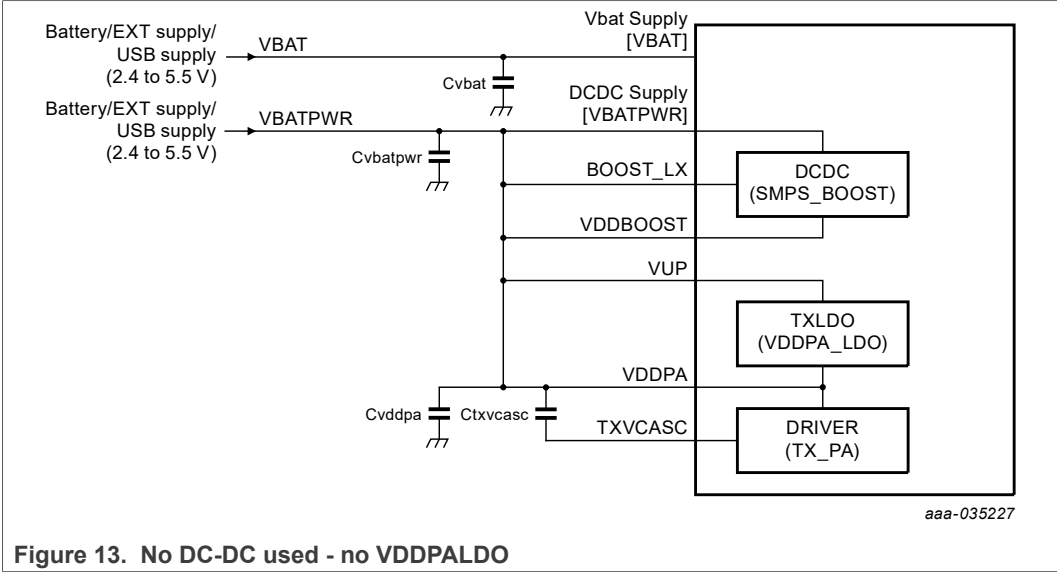

9.5.3.9 Supply voltage range for transmitter supply configuration examples

Table 5. Supply voltage range

Supply	Config1: VDDPALDO transmitter supply - DC-DC active	Config2: VDDPALDO transmitter supply - DC-DC bypassed	Config3: VDDPALDO transmitter supply connected to VBAT - no DC-DC	Config4: VDDPALDO supplied independent from VBAT - no DC-DC	Config5: VDDPALDO not used - no DC-DC
VBAT	2.8 V ... 4.8 V	2.8 V ... 4.8 V	2.4 V ... 5.5 V	2.4 V ... 5.5 V	2.4 V ... 5.5 V
VBATPWR	2.8 V ... 4.8 V	2.8 V ... 4.8 V	2.4 V ... 5.5 V	2.4 V ... 5.5 V	2.4 V ... 5.5 V
VUP	3.1 V ... 6.0 V	2.8 V ... 6.0 V	2.4 V ... 6.0 V	2.4 V ... 6.0 V	2.4 V ... 5.5 V
VDDPA	VUP-0.3V drop of VDDPALDO. max 5.7 V	VBATPWR - 0.5 V voltage drop	internally connected to VDDPALDO	internally connected to VDDPALDO	2.4 V ... 5.5 V

9.6 Clock generation

The device supports the operation with two clock options, which is configured in EEPROM address CLK_INPUT_FREQ (0012h).

One option is clocking by a crystal (default), the other a clocking by an external clock input frequency.

It is important to consider additional phase noise introduced e.g. by clock drivers in the design. Phase noise of the external clock will have an impact on the RF performance which can be achieved.

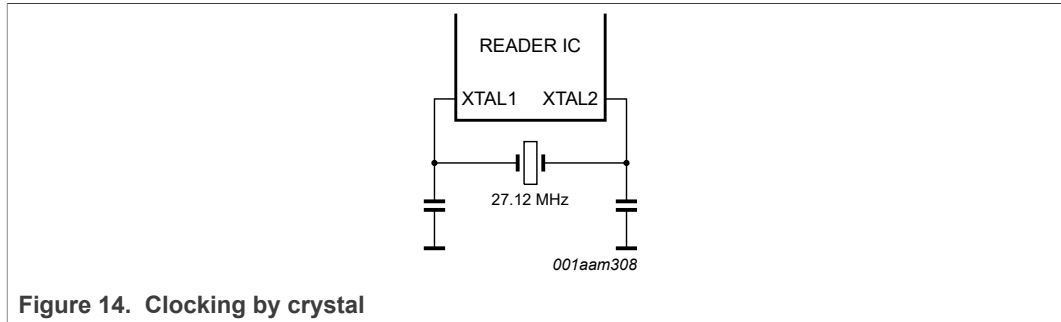

Figure 14. Clocking by crystal

9.7 External interfaces

The PN5190B1 requires the connection of a power supply, and a clock source like crystal or external clock and a host microcontroller connected by the SPI interface for operation.

Additional connections of the package require the connection of stabilizing capacitors and ground.

The RF interface connects transmitter and receiver to the EMC filter of a connected antenna matching network. Additional connections are available for the GPIO's (on PN5190B1 only outputs are implemented) and 2x DAC functionality (analog outputs).

The GPIO's implement internal Pull-up/Pull-down resistors. The output of the GPIO's can be configured in the pad configuration PAD_CONFIG (0052h).

For more information see [2].

9.8 Transmitter overcurrent and temperature protection ²

The PN5190B1 implements different mechanisms to protect the chip against damage.

On the one hand, an overcurrent protection exists which shuts down the Transmitter Driver in case of a out of spec current. This can be enabled in TXPALDO_CONFIG (000Ch), bit 11: overcurrent enable (0: disable, 1: enable)

On the other hand, an internal temperature sensor allows to monitor the temperature of the chip. This is configured in the register TEMP_WARNING (0048h). Three temperatures can be configured: 1:114 °C, 2:125 °C, 3:130 °C. GPIO1 is used to indicate this temperature warning to a connected host.

This is a safety feature only. A design shall not functionally rely on this feature since the operating conditions will be violated if the overcurrent detection becomes active.

9.9 Loading a dedicated RF configuration

The PN5190B1 allows an efficient selection of a dedicated RF protocol.

The selection of one RF protocol is done by sending a command to the PN5190B1. This instruction is used to load the RF configuration from EEPROM into registers.

It is possible to configure RF technology, mode (target/initiator) and baud rate.

Configurations can be loaded separately for the receiver (RX configuration) and transmitter (TX configuration).

The Command used for loading a dedicated RF protocol is LOAD_RF_CONFIGURATION (0Dh).

9.10 Dynamic power control (DPC)

The DPC is used for a special antenna tuning, called "symmetric antenna tuning". For an "asymmetric antenna tuning", the DPC is not required.

However, even for "asymmetric antenna tuning" with high output power needs, it might turn out that the RF field is too strong in close proximity of the antenna to be compliant with ISO/IEC14443 requirements. In this case, the DPC can be used as well to reduce the RF output power dependent on the distance of the card from the reader antenna.

The DPC works very well with a tuning called "symmetric tuning". With symmetric tuning, a detuning of the antenna is causing a reduction of the antenna impedance. This low antenna impedance might lead to a current which is too high for the targeted application. The DPC allows to limit the transmitter current even under antenna detuning conditions.

DPC is useful:

- To achieve EMVCo analog compliancy
- To achieve NFC Forum and ISO/IEC 14443 compliancy (e.g. NFC Forum Power Transfer Maximum, ISO/IEC 14443 Field Emission Maximum)
- To improve interoperability

The Dynamic Power Control (DPC 2.0) allows controlling the transmitter driver voltage in 100 mV steps dependent on the actual transmitter current.

² Please refer to the Errata sheet if the device is used with FW2.0 or FW2.1.

A lookup table is used to configure the transmitter output voltage and by this control the RF output power.

Features of the Dynamic power control (DPC 2.0):

- True current measurement provides maximum information for the regulation loop
- The transmitter current can be limited and additionally reduced according to detected transmitter current condition / antenna detuning condition
- DPC works autonomous without host interaction causing no additional processing load on the host
- Fastest response time of 1 ms for regulation
- Used for adaptive waveshape control (AWC)
- Used for adaptive RX sensitivity control (ARC)

The DPC is able to operate in two modes:

1. Current limiting mode
2. Current limiting + Current reduction mode

The DPC is configured in the EEPROM, this configuration is used after startup. This avoids that the host needs to configure the chip after each reset or power-off.

The following EEPROM registers are most relevant for the DPC configuration:

0xF8: DPC_Config: Enables/Disables the DPC (enable: 0x39, disable: 0x00)

0xF9: DPC_TargetCurrent: Unloaded VDDPA target current in mA, the target current +/- Hysteresis is limiting the current for the DPC.

- The DPC_TargetCurrent is the current which can be measured for the selected antenna impedance and transmitter supply voltage in unloaded condition. This is the current the system is designed to operate at.

0xFB: DPC_Hysteresis: Absolute difference to current target current in mA that triggers a DPC update event.

- The configuration of the hysteresis ensures, that the DPC is not regulating if small changes of the transmitter current occur due to external disturbances. A typical value for the DPC_Hysteresis is e.g. 20 mA.

0x8B: DPC_Lookup_Table: configures the current reduction

The DPC_LOOKUP_TABLE allows in addition to the limitation of the current, to configure

- an additional current reduction on top of the current limitation, achieved by further lowering the transmitter supply voltage
- a relative change of modulated amplitude level
- and a relative change of falling and raising edge time constant for ASK10% and ASK100% modulations

This lookup table is initialized with 0x00 for devices delivered from the factory. (The customer development board is already initialized with useful data in EEPROM which work well with the antenna of the board).

The 0x00 entry in the DPC_LOOKUP_TABLE means that no additional function then the current limitation takes place for the DPC.

In order to achieve a limitation of the current even in the case of an antenna impedance that is lowered, the Transmitter supply voltage is reduced accordingly.

This transmitter supply voltage reduction is now used as index for the DPC_LOOKUP_TABLE.

For a specific transmitter supply voltage, it is possible to further reduce the current below the value of DPC_TargetCurrent or to configure parameters for waveshaping and modulation. All these entries are relative values, granularity of the entries dependent on the transmitter supply voltage is 0.1 V, resulting in 42 table entries.

The DPC updates the content of the following register dependent on the antenna load / lookup table configuration:

0x30 - DGRM_RSSI

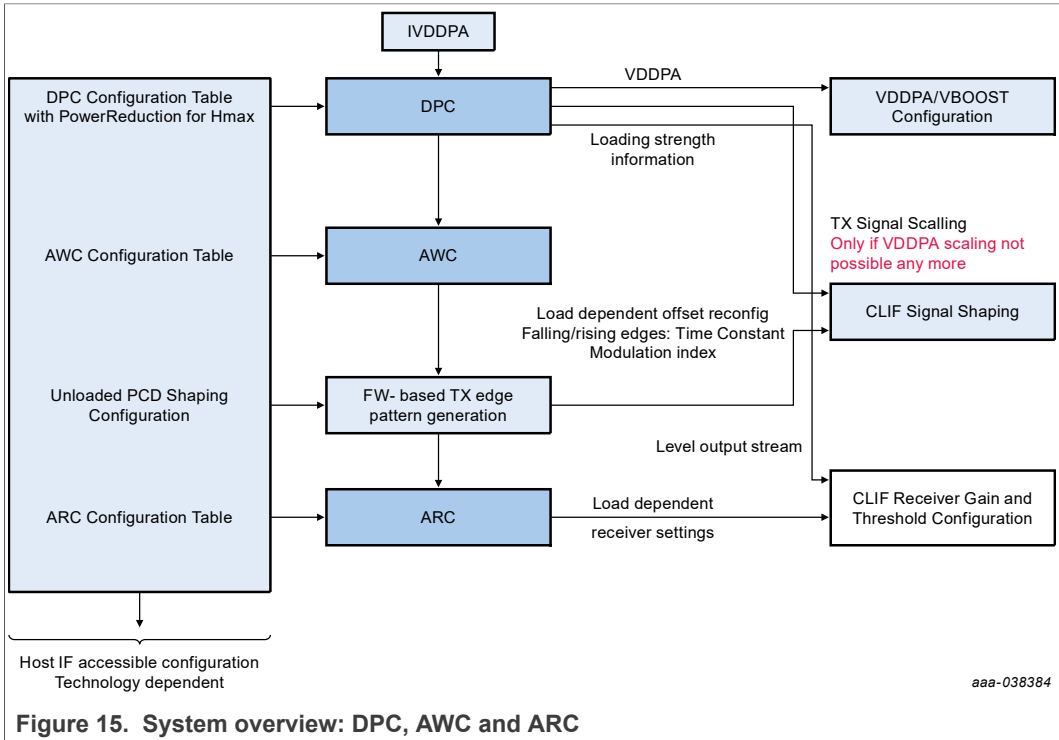

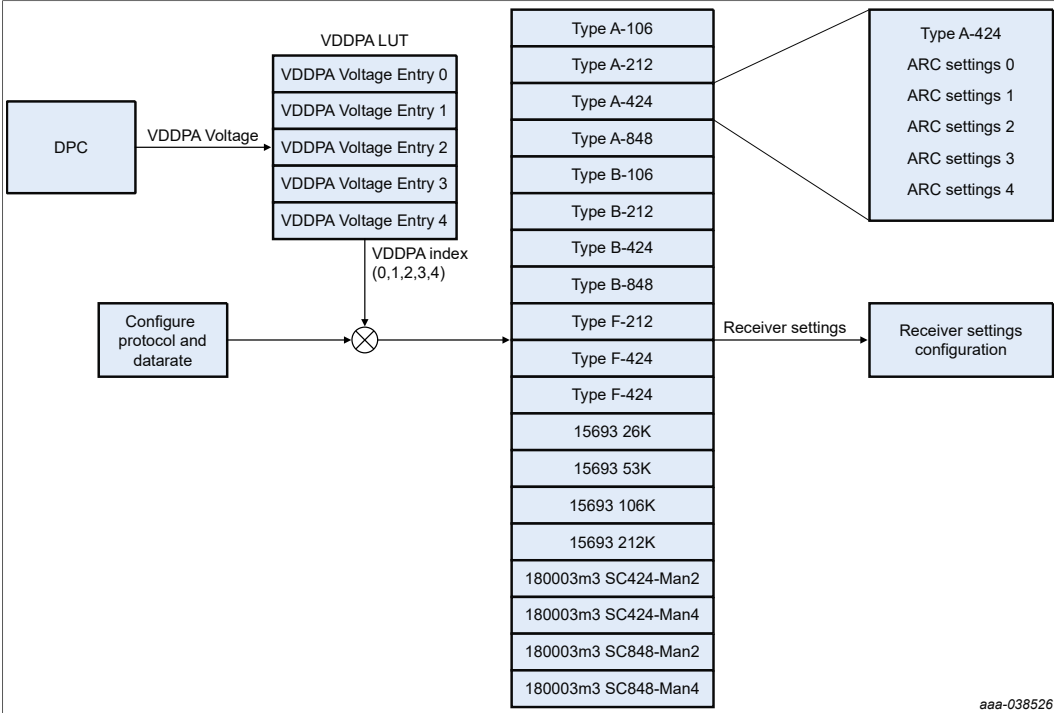

Figure 16. System overview: DPC, AWC and ARC

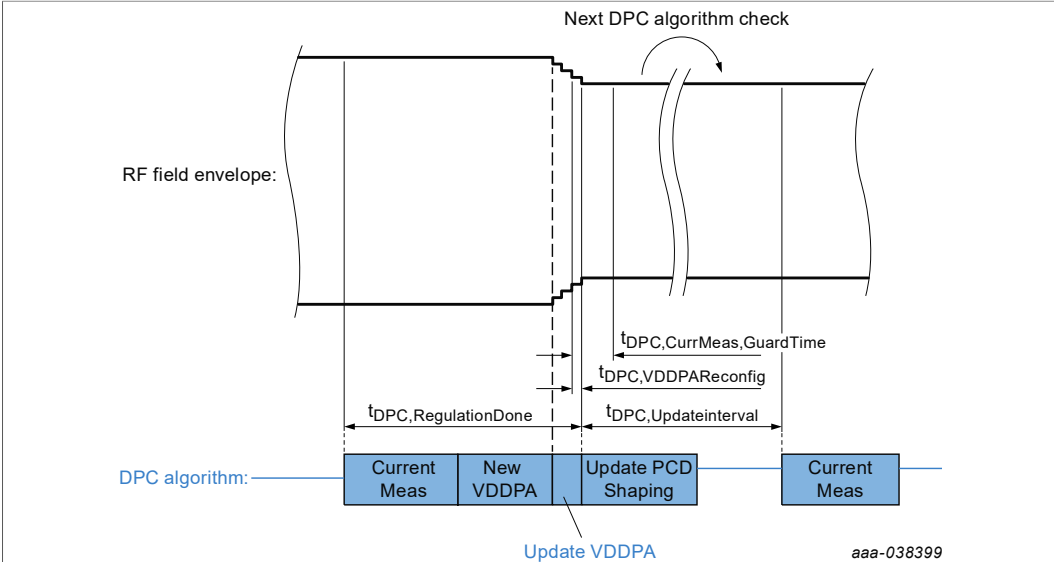

Figure 17. System overview: DPC, AWC and ARC

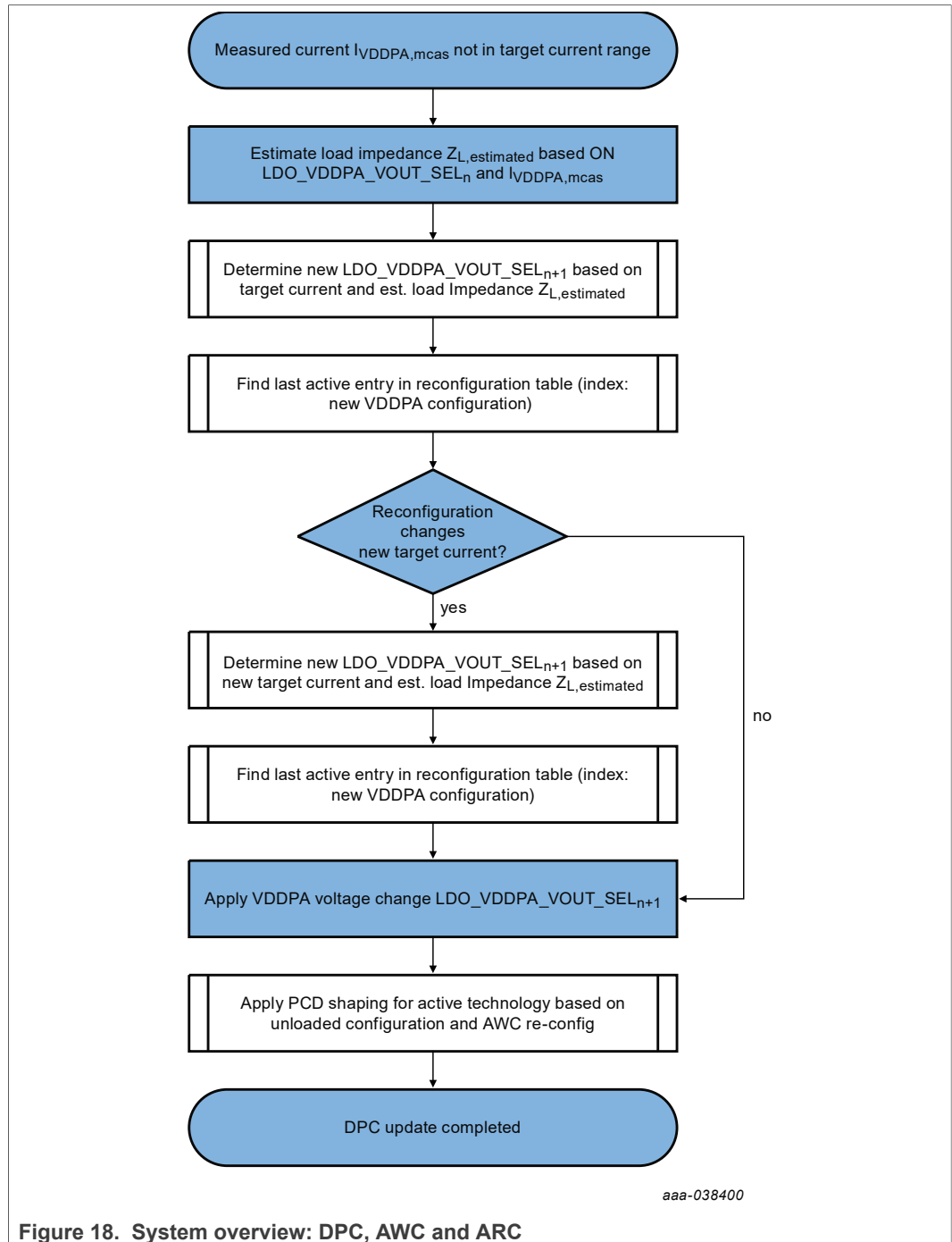

Figure 18. System overview: DPC, AWC and ARC

9.10.1 DPC algorithm

The DPC algorithm is controlling the transmitter current. It is using the following states:

1. Current measurement: Performs VDDPA current measurement
2. New VDDPA: Determine new VDDPA configuration based on measured current

$$\text{VDDPA New (for target current of } I_{\text{target}}) = \text{VDDPA Voltage} / \text{VDDPA current} * I_{\text{target}}$$
3. Update VDDPA: Perform output power update

- 4. Update PCD Shaping: Apply AWC configuration updates for active technology
- 5. Update RX sensitivity parameter only for short duration

Reconfiguration table includes Relative changes of target current and of waveform parameters adaption for all VDDPA voltage configurations. The VDDPA configuration is implicitly defined by the row index. The first row refers to LDO_VDDPA_VOUT_SEL=0 (represents 1V5).

EXAMPLE:

Unloaded configuration After Field ON:

VDDPA max set to 42 (5.7 V) · Target current set to 280 mA

Technology B106: amp_mod=200

Falling edge time constant=rising edge time constant=3

Table 6. DPC_LOOKUP_TABLE element, defining the configuration for one dedicated VDDPA voltage

Function	Bit	Description
ENTRY 0	31:0	This is the entry for 1.5 V.
Target current reduction	31:23	ENTRY 0 -LSB - byte 0 Voltage step between DPC entries = 100 mV. Voltage offset start = 1.5 V bEntry_00 = 1V5 ... bEntry_42 = 5V7 Bits[7:0] = Target current reduction in mA (unsigned)
AWC amp mod change	23:16	ENTRY 0 - byte 1 Bits[7:0] = Relative change of modulated amplitude level (signed)
AWC edge time constant for ASK100	15:8	ENTRY 0 - byte 2 Bits[3:0] = ASK100, Relative change of falling edge time constant (signed) Bits[7:4] = ASK100, Relative change of rising edge time constant (signed)
AWC falling edge time constant for ASK10	7:0	ENTRY 0 -MSB - byte 4 Bits[3:0] = ASK10, Relative change of falling edge time constant (signed) Bits[7:4] = ASK10, Relative change of rising edge time constant (signed)

Loaded configuration After Field ON:

DPC regulates from unloaded VDDPA configuration 42 to 31. Consequently, new configuration to be applied based on index entry 31.

Target current stays at 280 mA.

Technology B106: amp_mod=205, falling edge time constant=2, rising edge time constant=0

9.10.2 DPC characteristics

Table 7. Dynamic power control characteristics

Symbol	Parameter	Conditions	Min	Typ	Max	Unit
	Minimum hysteresis configured in EEPROM DPC_HYSTERESIS (address 079h)	Depends on application target current	ApplicationTargetCurrent * 0.0609 + 2 mA	-	-	mA

Table 7. Dynamic power control characteristics...continued

Symbol	Parameter	Conditions	Min	Typ	Max	Unit
	Max target current configured in EEPROM DPC_TARGET_CURRENT (077h)	Hysteresis as configured in DPC_HYSTERESIS (address 079h)		-	350-Hysteresis	mA

9.11 Adaptive waveshape control (AWC)

Depending on the level of detected detuning of the antenna, wave shaping related register settings can be automatically updated.

Two different waveshaping mechanisms can be used:

1. Firmware based shaping (1,2,3)
2. Lookup table based shaping (4,5,6)

The Firmware based shaping allows to correct rise times and overshoot with linear transition shapes.

The lookup table based shaping allows maximum flexibility and enables to configure almost any possible correction.

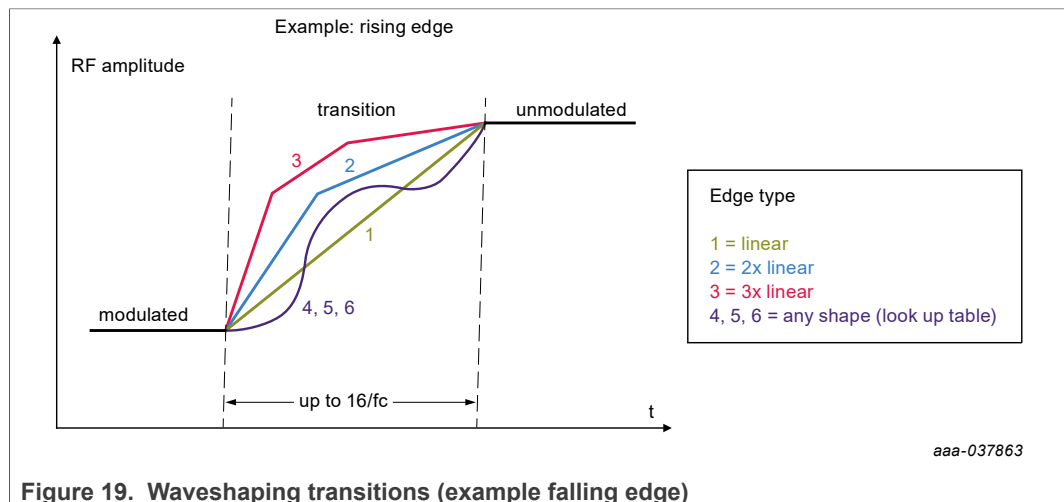

Figure 19. Waveshaping transitions (example falling edge)

The shaping related register settings are stored in a lookup table located in EEPROM, and selected dependent on the actual detected detuning condition.

Each lookup table entry allows the configuration not only of a dedicated wave shaping configuration for the corresponding detuning condition. But allows in addition to configure the wave shaping individually dependent on the actual protocol which is active.

Features of the Adaptive Waveshape Control:

- No external components required
- No need to compromise antenna matching to meet waveshape requirements
- Waveshapes automatically adapted according to detected detuning condition

- RF standards define envelope timing and residual carrier parameters required for compliance and interoperability.

The device supports the design of compliant antennas by allowing to actively shaping the style of edge transition for falling and rising edges. The shaping of modulation edges is achieved by selecting one from three edge transition styles:

1. Linear transition between two amplitude levels
2. Two linear transition's between amplitude levels and
3. Three linear transitions between amplitude levels.

The type of the transition is selected in the EEPROM registers EDGE_TYPE_(protocol), and can be defined independent for each RF protocol and data rate - for both falling and rising edge.

The EEPROM registers EDGE_STYLE_(protocol) define the time constant "s" of falling/rising edge (depends on edge style).

The EEPROM registers EDGE_LENGTH_(protocol) define the total length of the edge pattern.

The figures below illustrate the edge type for the falling edge.

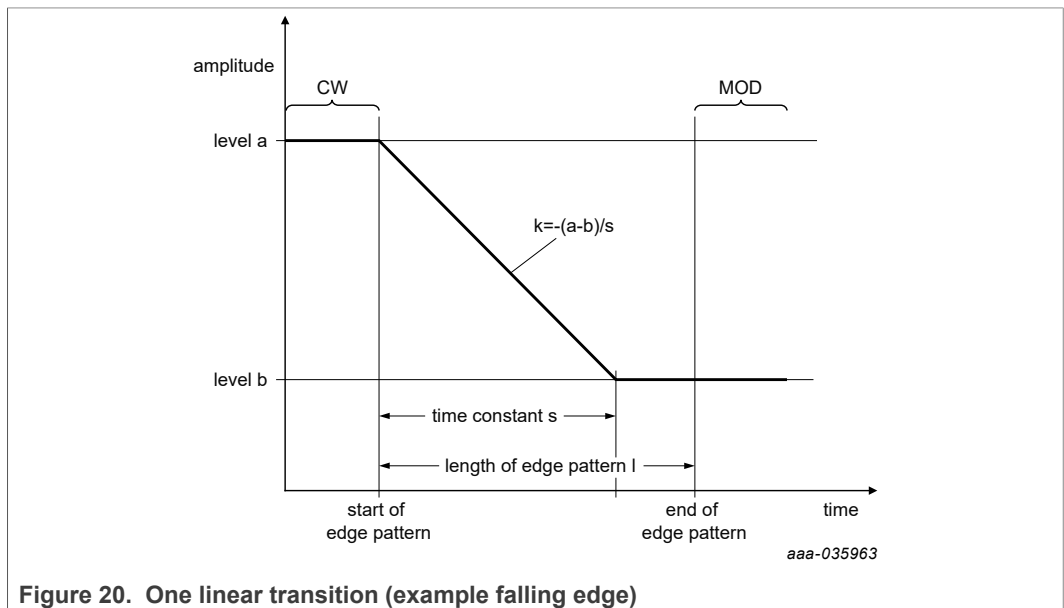

Figure 20. One linear transition (example falling edge)

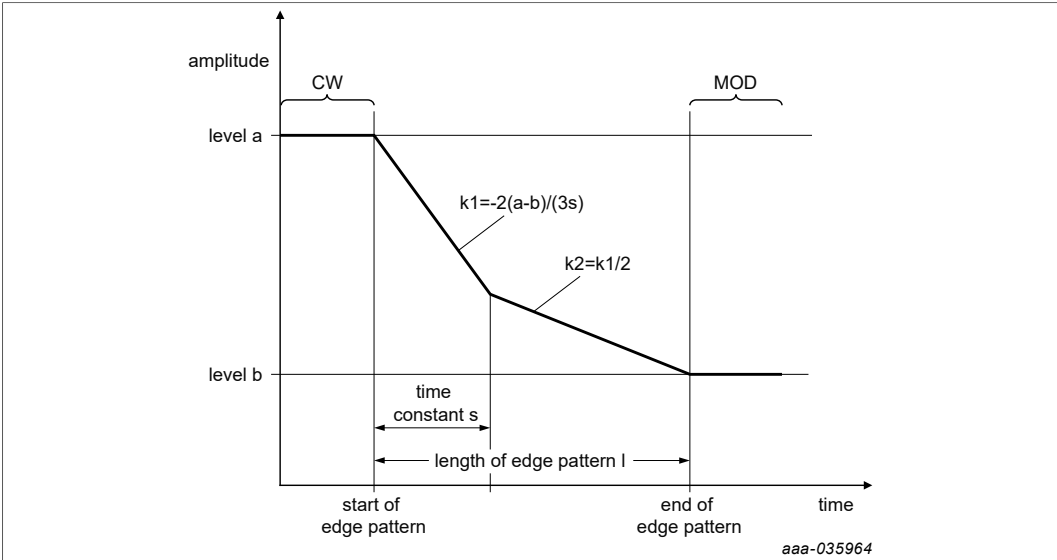

Figure 21. Two linear transitions (example falling edge)

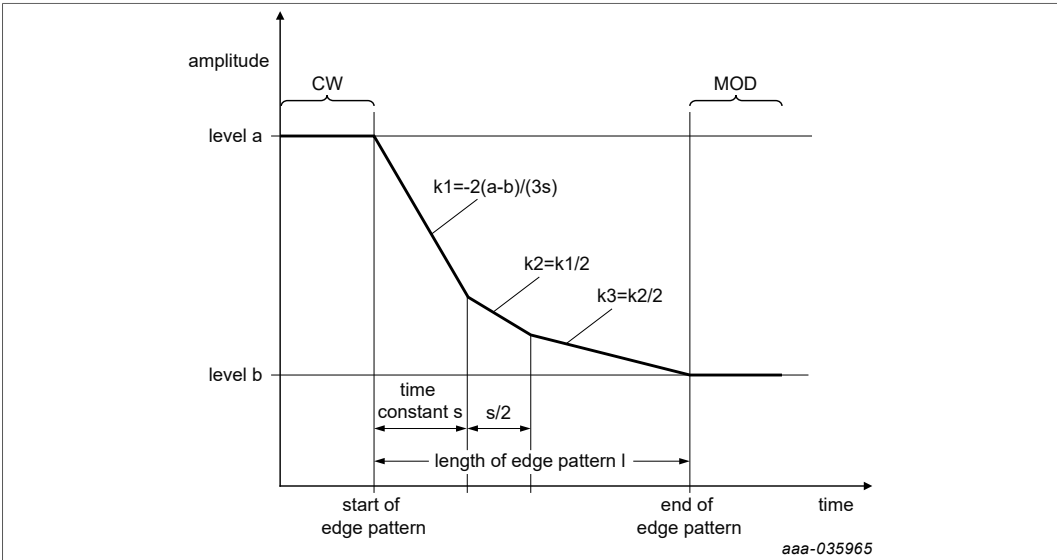

Figure 22. Three linear transitions (example falling edge)

The transition patterns are used as implicit pre-distortion to compensate effects of TX loading circuitry (e.g. resonant circuitry parameters) to the emitted RF envelope.

9.12 Adaptive receiver control (ARC)

Depending on the level of detected antenna detuning, receiver-related register settings can be automatically updated. The receiver-related registers which are allowed to be dynamically controlled are:

DGRM_RSSI_REG (30h) ->DGRM_SIGNAL_DETECT_TH_OVR_VAL

SIGPRO_RM_TECH_REG (22h) ->RM_MF_GAIN,

The adaptive receiver control settings override the default RM_MF_GAIN and DGRM_SIGNAL_DETECT_TH_OVR_VAL settings configured by the command LOAD_RF_CONFIGURATION (0Dh).

The ARC algorithm is called when VDDPA voltage changes after DPC. There are two lookup tables used in ARC algorithm i.e VDDPA lookup and ARC lookup. In case of a VDDPA change, an EEPROM lookup (at current protocol and baud rate) is performed. The receiver-related settings i.e RM_MF_GAIN, DGRM_SIGNAL_DETECT_TH_OVR_VAL and IIR_ENABLE are read from EEPROM lookup table and configured in registers.

VDDPA lookup table:

VDDPA lookup table define maximum five voltage ranges. Number of VDDPA voltage ranges used in ARC algorithm is configured in bArcConfig[2:0]. VDDPA voltage output from DPC algorithm is input to VDDPA lookup. VDDPA lookup returns VDDPA_range_index (i.e 0,1,2,3,4).

Table 8. ARC_VDDPA (0139Eh) EEPROM configuration bit description

Address (hex)	Function	Bit	Description
13D	ARC VDDPA Setting	7:0	Byte[4] = ARC_VDDPA_0: ARC_VDDPA_3 > VDDPA < ARC_VDDPA_4
13C		7:0	Byte[3] = ARC_VDDPA_0: ARC_VDDPA_2 > VDDPA < ARC_VDDPA_3
13B		7:0	Byte[2] = ARC_VDDPA_0: ARC_VDDPA_1 > VDDPA < ARC_VDDPA_2
13A		7:0	Byte[1] = ARC_VDDPA_0: ARC_VDDPA_0 > VDDPA < ARC_VDDPA_1
139		7:0	Byte[0] = ARC_VDDPA_0: 1.5 > VDDPA < ARC_VDDPA_0

ARC lookup table:

VDDPA index and RF protocol/datarates are input to ARC lookup. There are five Receiver settings entries for each protocol and data rates. ARC algorithm select one out of five entries (at current protocol and baud rate) based on VDDPA_range_index.

Following table show ARC settings for Type A-106.

Table 9. ARC_RM_A106 (address 013Eh) EEPROM configuration bit description

Address (hex)	Function	Bit	Description
146	RM_RX_ARC_4	15:0	Bit[15] 0: ARC settings always apply 1: ARC settings applicable during FDT, Bits[14:10] = RFU Bit [9] = Enable the IIR filter. Bits[8:7] = MF_GAIN (this value will be applied to the SIGPR_RM_TECH register, applies as soon as the ARC is enabled) Bits[6:0] = DPC_SIGNAL_DETECT_TH_OVR_VAL (this value will be applied to the DGRM_RSSI register, applies as soon as the ARC is enabled)

Table 9. ARC_RM_A106 (address 013Eh) EEPROM configuration bit description...continued

Address (hex)	Function	Bit	Description
144	RM_RX_ARC_3	15:0	Bit[15] 0: ARC settings always apply 1: ARC settings applicable during FDT, Bits[14:10] = RFU Bit [9] = Enable the IIR filter. Bits[8:7] = MF_GAIN (this value will be applied to the SIGPR_RM_TECH register, applies as soon as the ARC is enabled) Bits[6:0] = DPC_SIGNAL_DETECT_TH_OVR_VAL (this value will be applied to the DGRM_RSSI register, applies as soon as the ARC is enabled)
142	RM_RX_ARC_2	15:0	Bit[15] 0: ARC settings always apply 1: ARC settings applicable during FDT, Bits[14:10] = RFU Bit [9] = Enable the IIR filter. Bits[8:7] = MF_GAIN (this value will be applied to the SIGPR_RM_TECH register, applies as soon as the ARC is enabled) Bits[6:0] = DPC_SIGNAL_DETECT_TH_OVR_VAL (this value will be applied to the DGRM_RSSI register, applies as soon as the ARC is enabled)
140	RM_RX_ARC_1	15:0	Bit[15] 0: ARC settings always apply 1: ARC settings applicable during FDT, Bits[14:10] = RFU Bit [9] = Enable the IIR filter. Bits[8:7] = MF_GAIN (this value will be applied to the SIGPR_RM_TECH register, applies as soon as the ARC is enabled) Bits[6:0] = DPC_SIGNAL_DETECT_TH_OVR_VAL (this value will be applied to the DGRM_RSSI register, applies as soon as the ARC is enabled)
13E	RM_RX_ARC_0	15:0	Bit[15] 0: ARC settings always apply 1: ARC settings applicable during FDT and DPC change Bits[14:10] = RFU Bit [9] = Enable the IIR filter. Bits[8:7] = MF_GAIN (this value will be applied to the SIGPR_RM_TECH register, applies as soon as the ARC is enabled) Bits[6:0] = DPC_SIGNAL_DETECT_TH_OVR_VAL (this value will be applied to the DGRM_RSSI register, applies as soon as the ARC is enabled)

Note: For ISO14443-A: In case ARC is disabled, it requires DPC_SIGNAL_DETECT_TH_OVR_VAL larger than 0x50 (with MF_GAIN = 2 (default))

Note: For ISO14443-A: In case Bit[15] is configured to 0, it requires DPC_SIGNAL_DETECT_TH_OVR_VAL larger than 0x50 (with MF_GAIN = 2 (default)) if the ARC is enabled.

9.13 Timer

The PN5190B1 implements three different types of timers: 2 general-purpose timers (only general-purpose Timer0 is accessible by the user, Timer1 is used by the PN5190B1 as FDT Timer), 1 wake-up timer and 1 low frequency timer.

General-purpose timer

The PN5190B1 implements two 20-bit wide general-purpose timers - Timer0 and Timer1. Timer0 can be configured by 2 registers each (TIMER0_CONFIG, TIMER0_RELOAD).

Timer 1 is typically used for as FDT and EMD timer configuration. Configuration can be done from the host but the associated IRQ is handled by the firmware of the PN5190B1. The Timer1 events are consumed by the PN5190B1 FW and respective Time-out status is included as part of the command response.

The general-purpose Timer0 and the FTD Timer1 have a max count of 1.048.575.

The register TIMER0_CONFIG, TIMER0_RELOAD configure if either the 13.56 MHz clock of the RF interface is used as Timer input, or if a divided clock frequency is used as input. These registers configure as well the start conditions for the timer.

The following clock frequencies can be selected for the pre-scaler:

000b - 6.78 MHz counter

001b - 3.39 MHz counter

010b - 1.70 MHz counter

011b - 848 kHz counter

100b - 424 kHz counter

101b - 212 kHz counter

110b - 106 kHz counter

111b - 53 kHz counter

Wake-up timer

The PN5190B1 implements one 10-bit wide wake-up timer.

Max count of the wake-up timer is 1023, inout clock is the LFO CLK = 380 kHz. The max timeout is 269 ms.

The wake-up time is configured via the SWITCH_MODE_STANDBY / SWITCH_MODE_LPCD commands. There is no dedicated register available for this timer. The PN5190B1 enters the standby state by the switch mode command SWITCH_MODE_STANDBY/ SWITCH_MODE_LPCD. The counter value is part of the command and has to be sent as one configuration parameter. The 2-byte parameter value for the standby counter is indicating the counting time in milliseconds. The value needs to be provided in little-endian format.

Low frequency timer

The wakeup-counter for the ULPCD mode has a width of 12bits.

The input clock for this timer is 1 kHz. ULPCD uses the ULP_STANDBY command, and for this the wake-up timer is feed by the 1 kHz clock. Count down value (12 bits counter; $ULFO\ CLK / 4096 = 0.244\ Hz$ i.e. 1 ms per bit).

The max timeout is 4.096 s.

Timer for contactless interface

In addition to the timers above, to guarantee correct protocol timing, a guard period timer is implemented for the RF_EXCHANGE command in reception and transmission mode (TX_WAIT, RX_WAIT counting).

No configuration of this timer is available for the user, setup and counting is managed completely by the hardware. Therefore this timer is not indicated in the timer overview.

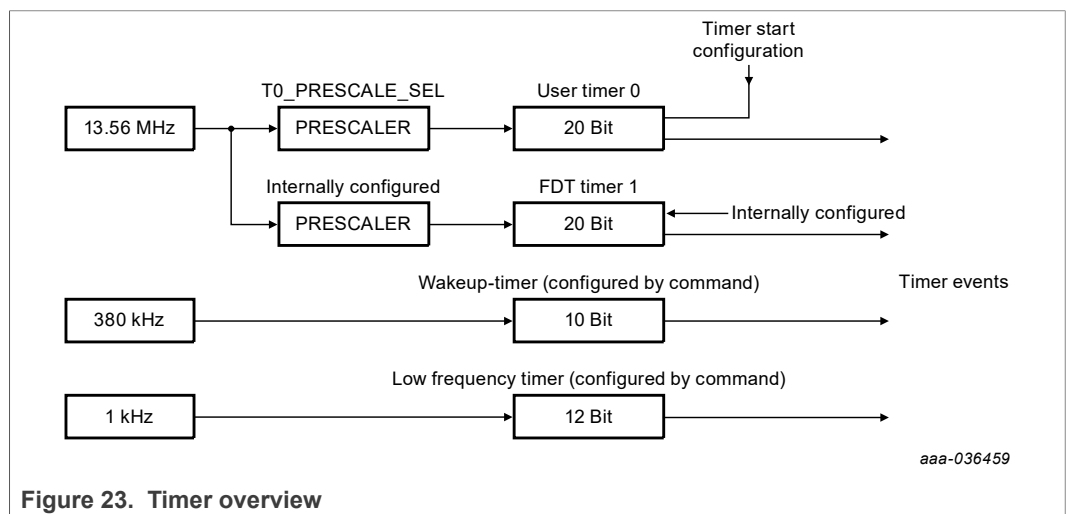

9.14 Low-power card detection

The low-power card detection (LPCD) and ultra-low power card detection (ULPCD) are an energy-saving card polling configuration for the PN5190B1. During LPCD, a host microcontroller can be set into power-saving mode, as no host controller interaction is required.

A low frequency timer is implemented to drive a wake-up counter, which triggers a periodic activation of the antenna drivers to emit a short pulse which allows to detect a detuning of the antenna. In case of a detected antenna detuning, the system is woken up from power-saving mode. It sends an interrupt signal to the connected host microcontroller to wake up the host microcontroller from power-saving mode and to indicate a change of the antenna detuning condition.

There is no trimming for the Low Frequency Timer required.

The SWITCH_MODE instruction allows entering the LPCD mode with a given standby duration value.

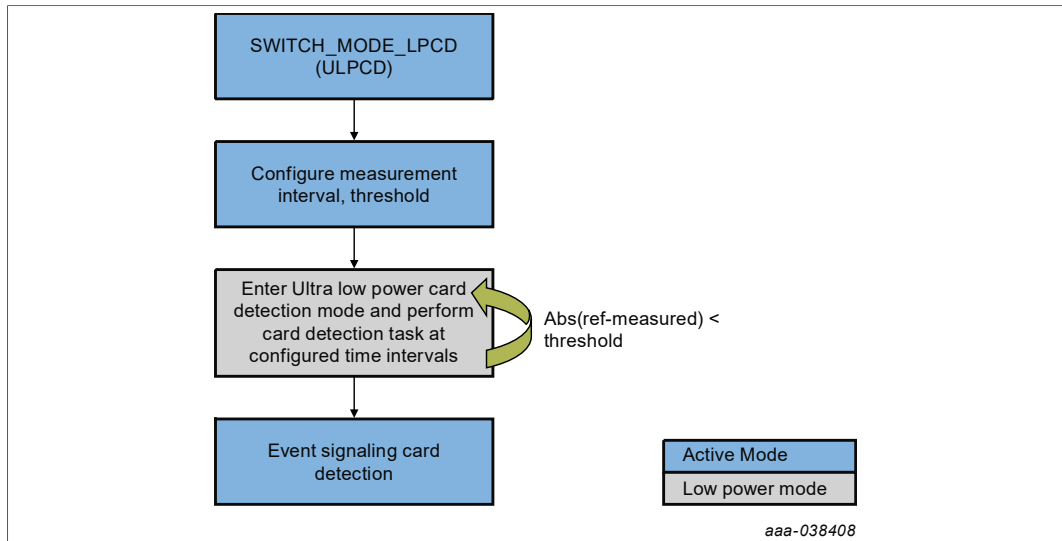

Figure 24. LPCD configuration and card detection loop

9.14.1 Low-power card detection (LPCD)

The low-power card detection (LPCD) is an energy-saving card polling configuration for the PN5190B1. During LPCD, a host microcontroller can be set into power-saving mode, as no host controller interaction is required. The host microcontroller is woken up from power-saving mode by an IRQ send by the PN5190B1.

The LPCD mode offers highest sensitivity at the cost of slightly higher current consumption compared to the ULPCD mode.

A low frequency oscillator (there is no trimming for the low frequency oscillator required) is implemented to drive a wake-up counter, which triggers a periodic activation of the antenna drivers to emit a short RF pulse. This RF pulse allows to detect a detuning of the antenna by presence of conductive objects in proximity of the antenna (card, cell phone, metal).

In case of a detected antenna detuning, the system wakes up from power-saving mode. It sends an interrupt signal to the connected host microcontroller to wake up the host microcontroller from power-saving mode and to indicate a change of the antenna detuning condition.

A low frequency oscillator (LFO) is implemented to drive a wake-up counter, waking-up PN5190B1 from standby mode. This allows implementation of low-power card detection polling loop at application level.

The host microcontroller can then perform a card polling sequence to verify if the technology of the object causing the antenna detuning is supported by the system.

The SWITCH_MODE instruction allows entering the LPCD mode with a given standby duration value.

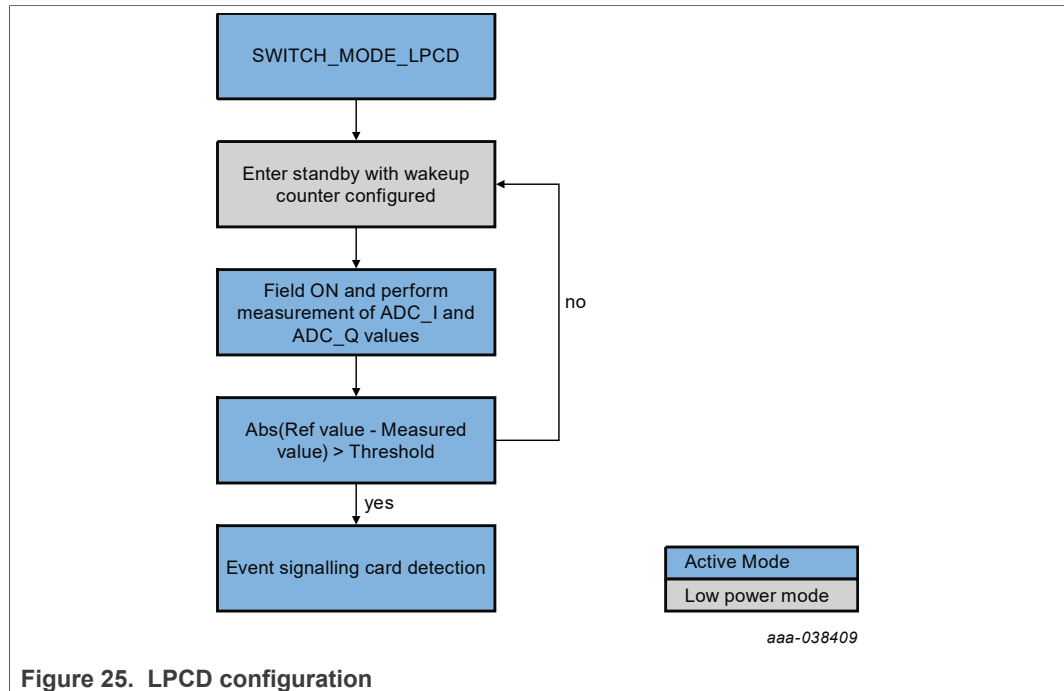

Figure 25. LPCD configuration

The LPCD mode is entered by the host interface command SWITCH_MODE_LPCD (23h), and terminated by the command SWITCH_MODE_NORMAL (20h). In addition, terminating the LPCD mode is possible by toggling a GPIO, by a reset (VEN) of the PN5190B1 or a signal of the RF Level detector.

Before entering the LPCD mode, ADC_I and ADC_Q reference value needs to be determined. This is done during the so called calibration.

LPCD calibration phase

- a) An initial calibration measurement is performed to set up the RX chain parameters namely HFATT, DCO_DAC_I_CTRL and DCO_DAC_Q_CTRL values.
- b) The next measurement is done using the RX chain parameters that are set up, to arrive at the ADC_I and ADC_Q values which are used as reference values. All following LPCD measurements are done relative to the LPCD calibration measurement.

The LPCD loop itself works in two phases:

First the standby phase is controlled by the wake-up counter (timing defined in the instruction), which defines the duration of the standby of the PN5190B1.

Second phase is the detection-phase. The RF field is switched on for a defined time (EEPROM configuration) and then the ADC_I and ADC_Q values are compared to a reference value.

- If the ADC_I and ADC_Q values exceed the reference value, a LPCD_IRQ is raised to the host. The register configurations done by the host to support a dedicated RF protocol are not restored after wake-up command. The host has to configure the NFC frontend for a dedicated protocol operation to allow a polling for a card.
- If the ADC_I and ADC_Q values do not exceed the thresholds of the reference value, no LPC_IRQ is raised and the IC is set to the first phase (standby mode) again.

These two phases are executed in a loop until:

- Card / metal is detected (LPCD_IRQ is raised).
- Reset occurs, which resets all the system configurations. The LPCD is also terminated in this case.
- NSS on host interface
- RF Level Detected
- GPIO toggle

As feature, the GPIO1 (general-purpose input/output) pin can be enabled to wake up an external DC-DC from power down for the VDDPA supply. The GPO1 allows setting to high before the transmitter is switched on. This allows the wake-up of an external DC-DC from power down. The GPO1 can be set to low after the RF field is switched off to set an external DC-DC into power-down mode. The time of toggling the GPO in relation to the RF-on and RF-off timings can be configured in EEPROM addresses 0xXX and 0xXX.

The behavior of the generated field is different dependent on the activation state of the DPC function:

- If the DPC feature is not active, the ISO/IEC14443 type A 106 kbit/s settings are used during the sensing time.
- If the DPC is active, the RF_ON command is executed. The RF field is switched on as soon as the timer configured by the SWITCH_MODE command elapses. The RF field is switched on for a duration as defined for an activated DPC. The timer for the LPCD_FIELD_ON_TIME starts to count as soon as the RF_ON command terminates.

Table 10. Low-Power Card Detection: relevant EEPROM configuration

EEPROM address	Name	Description
0492	LPCD_AVG_SAMPLES	Defines how many samples of the I and Q values are used for the averaging. Used to optimize the system to achieve highest detection sensitivity versus false alarms.
0494	LPCD_RSSI_TARGET	Value to be used as the RSSI target in the calibration phase to arrive at the RX chain parameters. This parameter is used to arrive at an optimal target voltage level at RXP.
0496	LPCD_RSSI_HYST	Value to be used as the RSSI hysteresis in the calibration phase to arrive at the RX chain parameters. This is used to avoid oscillations while arriving at the target voltage level at RXP.
049E	LPCD_THRESHOLD	If the difference between the measured value of I/Q and the reference value for I/Q is greater than the threshold on either channels, then a card is detected.
04B5	LPCD_VDDPA	VDDPA voltage when DC-DC (internal or external) or external power source is used to feed TXLDO
0013	XTAL_CHECK_DELAY	Interval which is used to check if XTAL is ready (unit is 256/fc, e.g. ~18.8 us). For fastest startup this time, a check is performed at a time slightly higher than the expected startup time of the crystal.

9.14.2 Semi-autonomous mode (LPCD)

LPCD semi-autonomous mode

The LPCD can be invoked by the host in the semi-autonomous mode wherein the ADC_I and ADC_Q values that are measured is returned back to the host.

In this mode, standby is not entered and the difference between the measured and reference values are not checked against the threshold. Nevertheless, the host may check the measured values against a reference and threshold to detect a card and also put the PN5190B1 in standby mode between measurements, using the SWITCH_MODE_STANDBY command.

This mode is especially useful to find optimized settings for the LPCD, since it does not offer no significant current saving.

Table 11. Low-Power Card Detection - semi-autonomous mode: relevant REGISTERS

REGISTER address	Name	Description
0050	LPCD_CALIBRATE_CTRL	Writing to this register triggers the LPCD calibration with the LPCD RSSI_HYSTERESIS and LPCD RSSI_TARGET values. After calibration is completed calibration status is available in LPCD_CALIBRATE_STATUS. If the calibration is successful, the I/Q channel values can be read from register IQ_CHANNEL_VALS
0051	IQ_CHANNEL_VALS	Actual I/Q channel value
0053	LPCD_CALIBRATE_STATUS	1: if successful - a new calibration clears this value

9.15 Automatic EMD error handling

The PN5190B1 supports a configurable EMD handling according to the ISO14443 or EMVCo standard. To support further extensions or changes of these standards, the EMD block is configurable.

After being configured, the PN5190B1 restarts both the receiver and a timeout timer automatically without host interaction in case of a detected EMD event.

Features of the Automatic EMD Error Handling:

- No real-time constraints
- Less processing load on the host processor
- Configurable, anticipating future specification changes

In addition to the EMD error handling according to ISO14443 and EMVCo, the PN5190B1 implements special features for FeliCa™ preamble processing.

Registers CLIF_RX_EMD_1_CONFIG(0x47) and CLIF_RX_EMD_0_CONFIG(0x48) hold the configurations for the EMD configurations for ISO/IEC14443, and NFC Forum.

EMVCo EMD configuration is supported in the register EMVCO_EMD_CONTROL (0x3).

9.16 Autocoll (card emulation)

The Autocoll state machine performs the time critical activation for Type-A PICC and for NFC-Forum Active and Passive Target activation (card emulation mode).

The PICC state machine supports three configurations:

- Autocoll mode0: Autocoll mode is left when no RF field is present
- Autocoll mode1: Autocoll mode is left when one technology is activated by an external reader. During RFOff, the chip enters standby mode automatically
- Autocoll mode2: Autocoll mode is left when one technology is activated by an external reader. During RFOff, the chip does not enter standby mode.

At start-up, the Autocoll state machine automatically performs a LOAD_RF_CONFIG with the General Target Mode Settings. When a technology is detected during activation, the Autocoll state machine performs an additional LOAD_RF_CONFIG with the corresponding technology.

The card configuration for the activation is stored in EEPROM. If RandomUID is enabled (EEPROM configuration), a random UID is generated after each RF-off.

For all active target modes, the own RF field is automatically switched on after the initiator has switched off its own field.

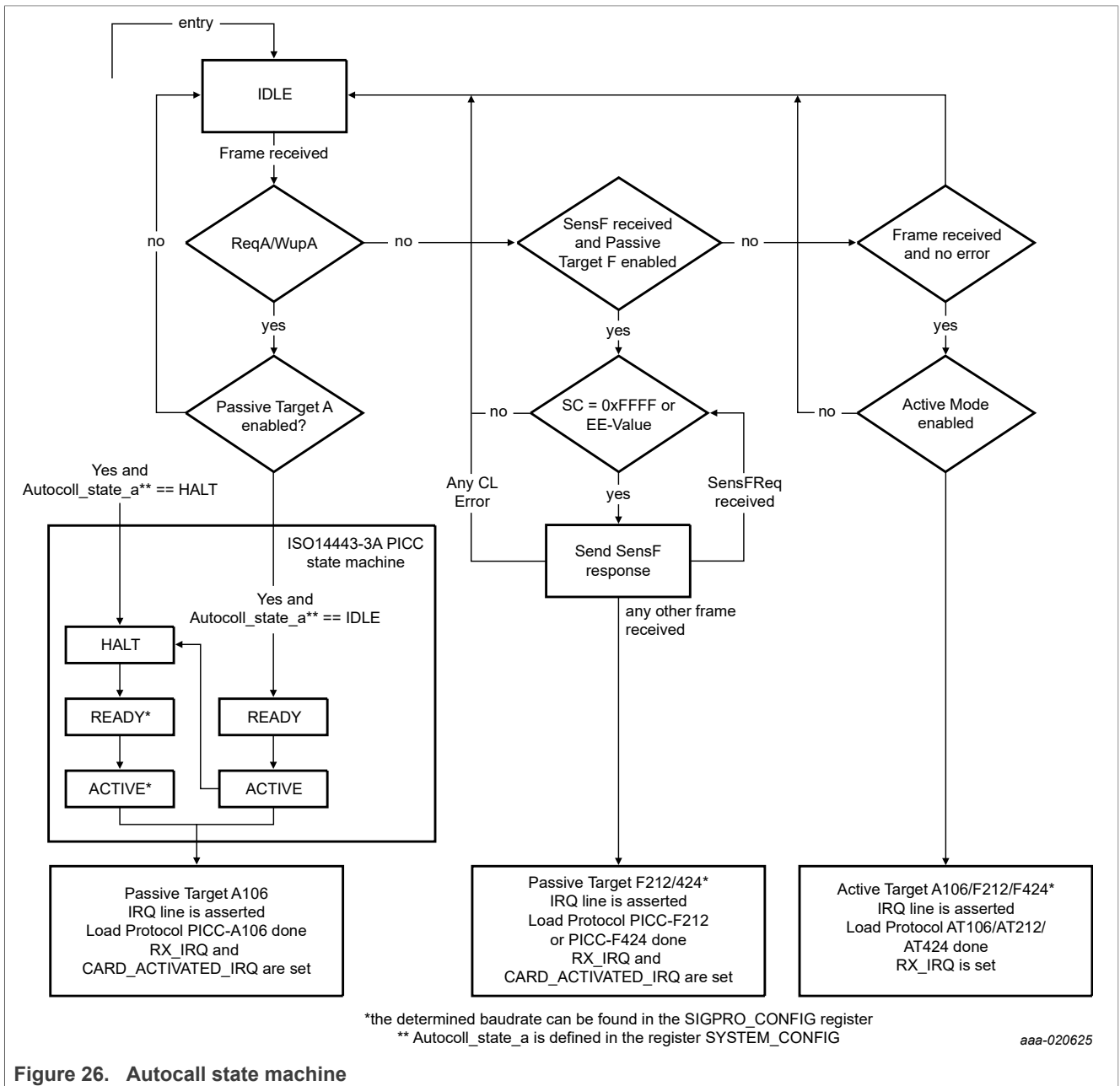

Figure 26. Autocoll state machine

9.17 RF-level detection

The PN5190B1 implements an RF level detector (RFLD) and an NFC level detector (NFCLD) which allows to detect the presence of an external RF field.

RF Level Detector:

During low-power card detection (LPCD), the RF level detector (RFLD) acts as wake-up source from power-saving mode.

During ultra low-power card detection (ULPCD), a specific ultra low-power RF level detector is used as RF level detector(RFLD). This can be enabled as wake-up source.

The purpose of the RFLD function is to detect any signal at 13.56 MHz in order to wake up the PN5190B1 from power-saving mode.

NFC Level Detector:

The NFC Level detector (NFCLD) is used during full power mode. The NFCLD function is required by NFC Forum to support the "RF collision avoidance".

The sensitivity of the NFCLD sensor can be configured by EEPROM register to meet the NFC Forum requirements.

It can be used as well in card mode to detect an external field.

9.18 Antenna tuning with variable capacitors

The PN5190B1. allows the tuning of the connected antenna based on variable capacitors.

Variable capacitors are devices which allow to change their capacity dependent on a supplied control voltage. Typically, these capacitors are used as serial and parallel capacitors in an antenna matching network.

The PN5190B1 allows to measure a detuning of the connected antenna caused e.g. by surrounding metal and correct the actual detuning by applying an appropriate control voltage on 2 analog outputs.

To correct a potential detuning of the connected antenna, a phase measurement needs to be performed. The following sequence is required to read out the phase information:

Step 1: Disable DPC

Step 2: Perform Type A-106 load protocol

Step 3: Set the VDDPA Voltage as $V_{(Vddpa_AAT)}$

Step 4: Perform RF ON

Step 5: Read out RXM phase

Step 6: Perform RF OFF

Step 7: Enable DPC

For reading the RXM phase, refer to the related application note. Based on the phase information, a host is able to calculate the DAC output voltages to correct a detuning.

The antenna tuning requires the DPC to be disabled, and is typically not suitable for dynamic tuning e.g. during card communication.

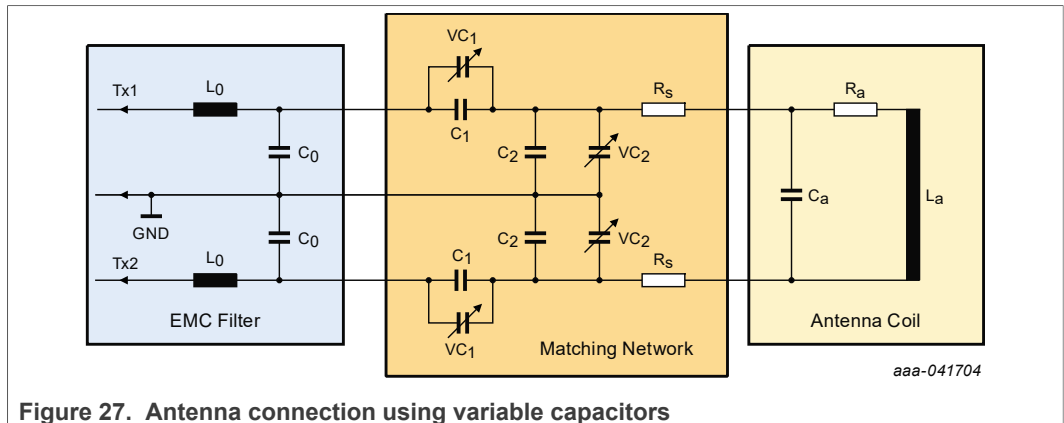

9.19 RF debug signals

The following signals are available for debugging purposes:

The test signals are selected by sending a command string to the PN5190B1. The commands CONFIGURE_TESTBUS_DIGITAL (12h) and CONFIGURE_TESTBUS_ANALOG (13h) are used to configure the dedicated signal on an output pin.

If used, **ADC-Q needs to be routed always to AUX1, ADC-I needs to be routed always to AUX2**

The analog test signals are analog representation of an internal digital value. The internal digital signal is converted by an 8-bit wide DAC to the analog signal.

This overview indicates the signals which are available for debugging purposes (indicated by numbers):

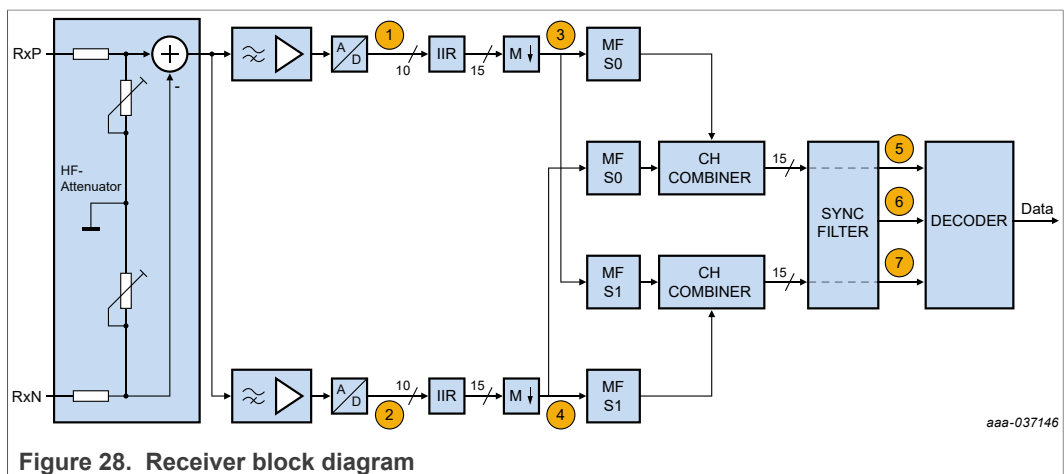

Table 12. DEBUG SIGNALS

Signal	REGISTER	SIGNAL NAME	BITS	Description
ADC Data I Channel (1)	obs_clif_tcontrol_patchbox0	adc_data_i_i	9:2	Unfiltered I channel signal upper 7 bit of the 10 bit signed unfiltered I channel signal including sign (bit9)

Table 12. DEBUG SIGNALS ...continued

Signal	REGISTER	SIGNAL NAME	BITS	Description
	obs_clif_tbcontrol_patchbox1		9; 6:0	Unfiltered I channel signal lower 7 bit of the 10 bit signed unfiltered I channel signal including sign (bit9)
ADC Data Q Channel (2)	obs_clif_tbcontrol_patchbox2	adc_data_q_i	9:2	Unfiltered Q channel signal upper 7 bit of the 10 bit signed unfiltered Q channel signal including sign (bit9)
	obs_clif_tbcontrol_patchbox3		9; 6:0	Unfiltered Q channel signal lower 7 bit of the 10 bit signed unfiltered Q channel signal including sign (bit9)
Preprocessor Out I Channel (3)	obs_clif_sigpro_rm0	rm_cor_adc_i_o	14:8	Pre-processed ADC data I channel upper 7bit of 15bit signed pre-processed ADC data I channel, after IIR Filter and down-sampling including sign (bit14) bit 15: RFU
	obs_clif_sigpro_rm1		7:0	Pre-processed ADC data I channel lower 8bit of 15bit signed pre-processed ADC data I channel, after IIR Filter and down-sampling
Preprocessor Out Q Channel (4)	obs_clif_sigpro_rm2	rm_cor_adc_q_o	14:8	Pre-processed ADC data I channel upper 7bit of 15bit signed pre-processed ADC data Q channel, after IIR Filter and down-sampling including sign (bit14) bit 15: RFU
	obs_clif_sigpro_rm3		7:0	Pre-processed ADC data I channel lower 8bit of 15bit signed pre-processed ADC data Q channel, after IIR Filter and down-sampling
Output MF S0 (5)	obs_clif_sigpro_rm4	mf_pt_s0_d	14:8	Delayed matched filter S0 output, after CH combiner upper 7 bit of the 15 bit signed delayed matched filter S0 output, after Channel combiner including sign (bit14) bit 15: RFU (ignore)
	obs_clif_sigpro_rm5		7:0	Delayed matched filter S0 output, after CH combiner lower 8 bit of the 15 bit signed delayed matched filter S0 output, after Channel combiner
Output MF S1 (6)	obs_clif_sigpro_rm6	mf_pt_s1_d	14:8	Delayed matched filter S1 output, after CH combiner upper 7 bit of the 15 bit signed delayed matched filter S1 output, after Channel combiner including sign (bit14) bit 15: RFU (ignore) Remark: S1 is not relevant for type A 106
	obs_clif_sigpro_rm7		7:0	Delayed matched filter S1 output, after CH combiner lower 8 bit of the 15 bit signed delayed matched filter S1 output, after Channel combiner Remark: S1 is not relevant for type A 106
Output Synchronization Filter (7)	obs_clif_sigpro_rm8	sync_filt_out	14:8	Synchronization filter output upper 7 bit of the 15 bit signed synchronization filter output including sign (bit14) bit 15: RFU (ignore)
	obs_clif_sigpro_rm9		7:0	Synchronization filter output lower 8 bit of the 15 bit signed synchronization filter output
clif_status	transceive_state		7:5	

Table 12. DEBUG SIGNALS ...continued

Signal	REGISTER	SIGNAL NAME	BITS	Description
	rx_cl_error		4	
	tx_envelope		3	
	rx_enevelope		2	
	svalid		1	
	sdata		0	
clif_transceive	rx_start_receive		7	
	rx_over_ok		6	
	rx_over_term		5	
	rx_resume		4	
	sgp_msg_busy		3	
	fig_reset_sigpro		2	
	fig_reset_rxdec		1	
	cfg_sw_reset_sigpro		0	

Table 13. TRIGGER SIGNALS

TRIGGER	REGISTER	SIGNAL NAME	BITS	Description
TX Active	obs_clif_txenc1	tx_active_o	1	high level indicates transmission of data Remark: Falling edge can be used to trigger on end of transmission.
RX Enable	obs_clif_sigpro_rm15	rx_enable_o	1	high level indicates that the reception is ongoing Remark: can be used to trigger on the start /end of reception
RX collision detected	obs_clif_sigpro_rm14	rm_scoll_o	1	high-level pulse indicates that the collision is detected during reception

9.20 Secure firmware update

The PN5190B1 supports a secure update of the implemented firmware.

The secure firmware download mode is using dedicated commands, but does not require a dedicated physical handling of the SPI interface lines.

The secure firmware download mode is entered by setting a register in non-volatile memory followed by a trigger of the VEN pin.

The firmware binary file which is used to update the PN5190B1 is protected with an RSA signature and AES encryption.

The key length of the RSA is 2048 bits, the public exponent supports any 32-bit integer value.

A pre-computed Montgomery format of signature is used, and the signature hash computation is based on SHA256 algorithm.

This prevents a download of any other software which is not released by NXP.

An anti-tearing function is implemented in order to detect supply voltage removal or memory fault.

During the secure firmware download, the NFC operation is not available, only the command set defined for the secure firmware download is valid.

Updating the PN5190B1 with the default firmware binaries programs the memories for user configuration with default values. Any previous user configuration will be overwritten. The user has to take care to restore the data of these memories after a secure firmware update.

If this is not intended, special firmware versions are available which do not overwrite the configuration. If the standard firmware file is named e.g. FW 2.00 , the name of the firmware which does not overwrite existing settings is then FW 2.F0. (The "F" is indicating the non overwrite version)

The PN5190B1 checks if the new major version number is equal or higher than the current one. In case the major version number of the new firmware to be installed is smaller than the already installed version number of the firmware, the secure firmware update is rejected. Downgrading major firmware versions is therefore not possible. Upgrading and therefore increasing major firmware versions is always possible.

In case of any failure or exception during the download (e.g. caused by a communication error or power-off), the PN5190B1 remains in the secure firmware download mode until a full firmware update sequence has been performed successfully.

Features of the automatic secure firmware update:

- Works without download request pin
- No special implementation of SPI interface handling
- Maximum integrity: Only encrypted and signed firmware images download possible
- Updating the firmware overwrites existing all previous EEPROM configurations.

9.21 SPI host interface

The interface of the PN5190B1 to a host microcontroller is based on a SPI interface.

The maximum SPI speed is 15 Mbit/s and fixed to CPOL = 0 and CPHA = 0. Only a half-duplex data transfer is supported. There is no chaining allowed, meaning that the whole instruction has to be sent or the whole receive buffer has to be read out. The whole transmit buffer shall be written at once as well. No NSS assertion is allowed during data transfer.

The SPI host interface is designed to support the typical interface supply voltages of 1.8 V and 3.3 V of CPUs. A dedicated supply input which defines the host interface supply voltage independent from other supplies is available (pin VDDIO).

There is no external pull-up / pull-down resistor required, the SPI pads are automatically configured by the PN5190B1.

Only a voltage of 1.8 V or 3.3 V is supported, but no voltage in the range of 1.95 V to 2.4 V.

Note: The Voltage on pin VDDIO must always be smaller or equal to the Voltage on pin VBAT.

Master in slave out (MISO)

The MISO line is configured as an output in a slave device. It is used to transfer data from the slave to the master, with the most significant bit sent first. The MISO signal is put into 3-state mode when NSS is high.

Master out slave in (MOSI)

The MOSI line is configured as an input in a slave device. It is used to transfer data from the master to a slave, with the most significant bit sent first.

Serial clock (SCK)

The serial clock is used to synchronize data movement both in and out of the device through its MOSI and MISO lines.

Not slave select (NSS)

The slave select input (NSS) line is used to select a slave device. It shall be set to low before any data transaction starts and must stay low during the transaction.

9.22 Host interface commands

9.22.1 Logical command layer

PN5190B1 has two main modes of operation to communicate with the host controller:

1. TLV-Command response-based communication
2. HDLL-Based communication, used when device is triggered to enter the “download mode”, to update its firmware.

The description of the transport layer in the next chapters is limited to TLV-based command-response communication.

For more information see [\[3\]](#).

9.22.1.1 Logical frame definition

A SPI frame starts with the falling edge of NSS and ends with the rising edge of NSS.

SPI is per physical definition full duplex but PN5190B1 uses SPI in a half-duplex mode.

SPI mode is limited to CPOL 0 and CPHA 0 with a max clock speed of 15 MHz.

Every SPI frame is composed of a 1-byte header and n-bytes of body.

9.22.1.2 Logical flow definition

The HOST always sends as a first byte the flow indication byte whether it wants to write or read data from the PN5190B1.

In case of a read request and no data is available, the response contains 0xFF.

The data after the flow indication byte is one or several messages.

For every NSS assertion, the first byte is always a HEADER (flow indication byte), it can be either 0x7F/0xFF with respect to write/read operation.

9.22.1.3 Logical message type definition

A host controller communicates with PN5190B1 using messages which are transported within SPI frames.

There are three different message types:

- Command
- Response
- Event

Commands are only sent from host controller to PN5190B1 responses.

Events are only sent from PN5190B1 to host controller.

Allowed sequences and rules:

- Command is always acknowledged by a response
- Host Controller is not allowed to send another command before receiving a response to a previous command, except in concatenation
- Events may be sent asynchronously at any time (NOT interleaved within a command/response pair)
- EVENT messages are never combined with the RESPONSE messages within one frame.

9.22.1.4 Logical message format

Type (T) => 1 byte

Bit[7] Message Type

0: COMMAND or RESPONSE message

1: EVENT message

Bit[6:0]: Instruction Code

Length (L) => 2 bytes (large endian format)

Length of the message body

Value (V) => N bytes

Value/data of the TLV (Command Parameters / Response data) based on Length field (Large endian format)

9.22.1.5 Split frame definition

COMMAND message must be sent in one SPI frame RESPONSE and EVENT messages can be read in multiple SPI frames, e.g., to read out the length byte.

RESPONSE and EVENT messages can be read in single SPI frame but delayed by NO-CLOCK in between, e.g., to read out the length byte.

9.22.2 Host interface command list

PN5190B1 command/response list

Table 14. Host interface commands

Command code	PN5180 legacy command	Command
0x00	Yes	WRITE_REGISTER

Table 14. Host interface commands...continued

Command code	PN5180 legacy command	Command
0x01	Yes	WRITE_REGISTER_OR_MASK
0x02	Yes	WRITE_REGISTER_AND_MASK
0x03	Yes	WRITE_REGISTER_MULTIPLE
0x04	Yes	READ_REGISTER
0x05	Yes	READ_REGISTER_MULTIPLE
0x06	Yes	WRITE_EEPROM
0x07	Yes	READ_EEPROM
0x08	No	TRANSMIT_RF_DATA
0x09	No	RETRIEVE_RF_DATA
0x0A	No	EXCHANGE_RF_DATA
0x0B	Yes	MFC_AUTHENTICATE
0x0C	Yes	EPC_GEN2_INVENTORY
0x0D	Yes	LOAD_RF_CONFIGURATION
0x0E	Yes	UPDATE_RF_CONFIGURATION
0x0F	Yes	GET_RF_CONFIGURATION
0x10	Yes	RF_ON
0x11	Yes	RF_OFF
0x12	Yes	CONFIGURE_TESTBUS_DIGITAL (not available for engineering samples)
0x13	Yes	CONFIGURE_TESTBUS_ANALOG (not available for engineering samples)
0x14	No	CTS_ENABLE
0x15	No	CTS_CONFIGURE
0x16	No	CTS_RETRIEVE_LOG
0x17 - 0x19	-	RFU
0x1A		RECEIVE_RF_DATA
0x1B-0x1F		RFU
0x20	Yes	SWITCH_MODE_NORMAL
0x21	Yes	SWITCH_MODE_AUTOCOLL
0x22	Yes	SWITCH_MODE_STANDBY
0x23	No	SWITCH_MODE_LPCD
0x24	No	SWITCH_MODE_SUSPEND
0x25	No	SWITCH_MODE_DOWNLOAD
0x26	No	GET_DIE_ID
0x27	No	GET_VERSION
0x28 - 0x3F	-	RFU

Table 14. Host interface commands...continued

Command code	PN5180 legacy command	Command
0x40	-	RFU
0x41	No	PRBS_TEST
0x41 - 0x50	-	RFU

9.22.3 Command WRITE_REGISTER (00h)

Description

This instruction is used to write a 32-bit value (little endian) to a logical register.

Conditions

The address of the register must exist and the register must either have the READ-WRITE or WRITE-ONLY attribute.

Event

There are no events for this command.

Command

Table 15. WRITE_REGISTER

Payload	Length (byte)	Value/Description
Command code	1	0x00
Parameter	1	Register address
	4	Register content
Response	1	Status 0x00: STATUS_SUCCESS 0x018: STATUS_INSTR_ERROR

9.22.4 Command WRITE_REGISTER_OR_MASK (01h)

Description

This instruction is used to modify the content of register using a logical OR operation. The content of the register is read and a logical OR operation is performed with the provided mask. The modified content is written back to the register.

Conditions

The address of the register must exist and the register must either have the READ-WRITE or WRITE-ONLY attribute.

Event

There are no events for this command.

Command

Table 16. WRITE_REGISTER_OR_MASK

Payload	Length (byte)	Value/Description
Command code	1	0x01
Parameter	1	Register address
	4	4 byte bitmask: Bitmask used as operand for logical OR operation.
Response	1	Status 0x00: STATUS_SUCCESS 0x018: STATUS_INSTR_ERROR

9.22.5 Command WRITE_REGISTER_AND_MASK (02h)

Description

This instruction is used to modify the content of register using a logical AND operation. The content of the register is read and a logical AND operation is performed with the provided mask. The modified content is written back to the register.

Conditions

The address of the register must exist and the register must either have the READ-WRITE or WRITE-ONLY attribute.

Event

There are no events for this command.

Command

Table 17. WRITE_REGISTER_AND_MASK

Payload	Length (byte)	Value/Description
Command code	1	0x02
Parameter	1	Register address
	4	Bitmask Bitmask used as operand for logical AND operation.
Response	1	Status 0x00: STATUS_SUCCESS 0x018: STATUS_INSTR_ERROR

9.22.6 Command WRITE_REGISTER_MULTIPLE (03h)

Description

This instruction behaves like WRITE_REGISTER, WRITE_REGISTER_OR_MASK and WRITE_REGISTER_AND_MASK with the possibility to combine them. In fact, it takes an array of register-type-value set and performs appropriate action. The type reflects the action which is either write register, logical OR operation on a register or logical AND operation on a register.

Conditions

The respective logical address of the register within a set must exist. The register access attribute must allow execution of required action (type):

- Write action: READ-WRITE or WRITE-ONLY attribute
- OR mask action: READ-WRITE attribute
- AND mask action: READ-WRITE attribute

The size of the parameter array must be in the range from 1 – 43, inclusive. Field ‘Type’ must be in the range of 1 – 3, inclusive.

In case of an exception, the operation is not rolled-back, i.e. registers which have been modified until the exception occurs remain in modified state. Host has to take care to recover a defined state.

Event

There are no events for this command.

Command

Table 18. WRITE_REGISTER_MULTIPLE

Payload	Length (byte)	Value/Description	
Command code	1	0x03	
Parameter	6...258 (6 x 1...6 x 43)	Array of up to 43 {Register address element, Action element, Content element}	
		1 byte	Register address element
		1 byte	Type 0x01: Write Register 0x02: Write Register OR Mask 0x03: Write Register AND Mask
		4 bytes	Content element 32-bit register value which has to be written to register address, or 32-bit bitmask used for logical operation with content available at register address
Response	1	Status: 0x00: STATUS_SUCCESS 0x018: STATUS_INSTR_ERROR	

9.22.7 Command READ_REGISTER (04h)

Description

This instruction is used to read a 32-bit value (little endian) to a register. The register content is present in the response, as 4 byte value.

Conditions

The address of the register must exist.

The register must either have the READ-WRITE or WRITE-ONLY attribute.

Event

There are no events for this command.

Command

Table 19. READ_REGISTER

Payload	Length (byte)	Value/Description
Command code	1	0x04
Parameter	1	Register address Address of the register to be read out
Response	1	Status 0x00: STATUS_SUCCESS 0x018: STATUS_INSTR_ERROR
	4	Register content 32-bit register value which has been read out.

9.22.8 Command READ_REGISTER_MULTIPLE (05h)

Description

This instruction is used to read multiple logical registers at once. The result (content of each register) is provided in the response to the instruction. The register address itself is not included in the response. The order of the register contents within the response corresponds to the order of the register addresses provided within the instruction.

Conditions

All register addresses within the instruction must exist. The access attribute for each register must either be READ-WRITE or READ-ONLY. The size of 'Register Address' array must be in the range from 1 – 18, inclusive.

Event

There are no events for this command.

Command

Table 20. READ_REGISTER_MULTIPLE

Payload	Length (byte)	Value/Description
Command code	1	0x05
Parameter	1..18	Array of up to 18 elements {Register address element }
		1 Register address element Register address to be read out

Table 20. READ_REGISTER_MULTIPLE...continued

Payload	Length (byte)	Value/Description
Response	1	Status 0x00: no error 0x01: error
	4...72	Array of up to 18 {Register content element}
		4..72

9.22.9 Command WRITE_EEPROM (06h)

Description

The accessible area in EEPROM is 5119 bytes long and starts at EEPROM address 0.

This instruction is used to write one or more values to EEPROM. The field 'Values' contains the data to be written to EEPROM starting at the address given by field 'EEPROM Address'. The data is written in sequential order.

This is a blocking command, the device is blocked during the write operation. This will take approximately 2.85 ms, termination of the EEPROM write (programming) is indicated by the response to the command.

Conditions

'EEPROM Address' field must be in the range from 0 – 5119, inclusive. Write operation must not go beyond EEPROM address 5119. Error response will be sent to the host if address exceeds 5119.

Event

There are no events for this command.

Command

Table 21. WRITE_EEPROM

Payload	length (byte)	Value/Description
Command code	1	0x06
Parameter	2	EEPROM Address Address in EEPROM from which write operation starts {EEPROM Address}
	1..5119	Array of up to 5119 {EEPROM content element}
		EEPROM content
	1..5119	Byte Values which have to be written to EEPROM in sequential order
Response	-	Status 0x00: no error 0x01: ERROR due to wrong address 0x02: PROGRAMM ERROR

9.22.10 Command READ_EEPROM (07h)

Description

This instruction is used to read back data from EEPROM memory area. The field ‘EEPROM Address’ indicates the start address of the read operation. The response contains the data read from EEPROM.

Conditions

‘EEPROM Address’ field must be in the range from 0 – 5120, inclusive. Read operation must not go beyond EEPROM address 5120. Error response shall be sent to the host if the address exceeds 5120.

Event

There are no events for this command.

Command

Table 22. READ_EEPROM

Payload	Length (byte)	Value/Description
Command code	1	0x07
Parameter	2	Address in EEPROM from which read operation starts (EEPROM Address)
	2	Number of bytes to read from EEPROM
Response	1	0x00: no error 0x01: error
	1...1024	Array of up to 1024 bytes {EEPROM content}
	1	EEPROM content

9.22.11 Command TRANSMIT_RF_DATA (08h)

Description

This instruction is used to write data into the internal CLIF transmission buffer and start transmission. The size of this buffer is limited to 1024 bytes. After this instruction has been executed, an RF reception is started automatically.

The command returns immediately after Transmission is complete not waiting for the reception completion.

Conditions

The number of bytes within the ‘TX Data’ field must be in the range from 1 – 1024, inclusive.

The command must not be called during an ongoing RF transmission.

Event

There are no events for this command.

Command

Table 23. TRANSMIT_RF_DATA

Payload	Length (byte)	Value/Description
Command code	1	0x08
Parameter	1	Number of valid bits in last Byte: 0x00: All bits of last byte are transmitted 0x01...0x07: Number of bits within last byte to be transmitted
	1-1024	TxData Data which shall be used during next RF transmission
Response	1	Status 0x00 no error 0x01 error 0x02 RF Field is not switched on (if reader mode is active) 0x03 no RF Field present (if target mode is active)

9.22.12 Command RETRIEVE_RF_DATA (09h)**Description**

This instruction is used to read data from the internal CLIF RX buffer, which contains the RF response data (if any) posted to it from the previous execution of EXCHANGE_RF_DATA with option not to include the received data in the response or TRANSMIT_RF_DATA command.

Conditions**Event**

There are no events for this command.

Command

Table 24. RETRIEVE_RF_DATA

Payload	Length (byte)	Value/Description
Command code	1	0x09
Parameter	0	Empty
Response	1	Status of the operation: 0x00: PN5190B1_STATUS_INSTR_SUCCESS 0x18: PN5190B1_STATUS_INSTR_ERROR (No further data is present)
	1...1024	RX data which has been received during last successful RF reception expected from executing the commands EXCHANGE_RF_DATA or TRANSMIT_RF_DATA

9.22.13 Command EXCHANGE_RF_DATA (0Ah)

Description

The RF exchange function performs a transmission of the TX data and is waiting for the reception of any RX data.

The function returns in case of a reception (either erroneous or correct) or a timeout that happened. The timer is started with the END of TRANSMISSION and stopped with the START of RECEPTION. The timeout value pre-configured in EEPROM will be used.

If transceiver_state is

- IDLE: the Exchange Data mode is entered.
- WAIT_RECEIVE: the transceiver state is reset to Exchange Data Mode in case of initiator bit is set
- WAIT_TRANSMIT: the transceiver state is reset to Exchange Data Mode in case initiator bit is NOT set

The field 'Number of valid bits in last Byte' indicates the exact data length to be transmitted. The command terminates after end of transmission and end of reception.

Conditions

Size of 'TX Data' field must be in the range from 0 – 1024, inclusive.

'Number of valid bits in last Byte' field must be in the range from 0 – 7.

The command must not be called during an ongoing RF transmission. Command shall ensure the right state of the Transceiver for transmitting the data.

Event

There are no events for this command.

Command

Table 25. EXCHANGE_RF_DATA

Payload	Length (byte)	Value/Description
Command code	1	0x0A
Parameter	1	Number of valid bits in last Byte: 0: All bits of last byte are transmitted 1-7: Number of bits within last byte to be transmitted
	1	RF Exchange Config Configuration of the RFExchange function.
	0 - 1024	TxDATA Data which has to be sent out via CLIF using EXCHANGE_RF_DATA command. Length = 0 – 1024 bytes
Response	1	Status 0x00 no error 0x01 Timeout 0x10 RF Field is not switched on (if reader mode is active) 0x18 error (in payload)
	4	RX_STATUS If RX_STATUS is requested in RF Exchange Config parameter

Table 25. EXCHANGE_RF_DATA...continued

Payload	Length (byte)	Value/Description
	4	RF_STATUS If RF_STATUS is requested in RF Exchange Config parameter
	4	EVENT_STATUS If EVENT_STATUS is requested in RF Exchange Config parameter
	1-1024	Rx_Data RX data which has been received during last successful RF reception.

Table 26. EXCHANGE_RF_DATA Parameter RF Exchange Config: Bitmask

Bitmask / Bit position									Description
B7	B6	B5	B4	B3	B2	B1	B0		
X	X	X	X					RFU	
				X				Include RX Data in response based on RX_STATUS, if bit set to 1b.	
					X			Include EVENT_STATUS register in response, if bit set to 1b.	
						X		Include RF_STATUS register in response, if bit is set to 1b.	
							X	Include RX_STATUS register in response, if bit is set to 1b.	

9.22.14 Command MFC_AUTHENTICATE (0Bh)

This command is used to perform a MIFARE Classic Authentication on an activated card. It takes the key, card UID and the key type to authenticate at given block address. The response contains one byte indicating the authentication status.

Conditions

Field 'Key' must be 6 bytes long. Field 'Key Type' must contain the value 0x60 or 0x61. Block address may contain any address from 0x00 – 0xFF, inclusive. Field 'UID' must be bytes long and should contain the 4 byte UID of the card. An ISO14443-3 MIFARE Classic card should be put into state ACTIVE or ACTIVE* prior to execution of this instruction.

In case of a runtime error related to the authentication, the field 'Authentication Status' is set accordingly.

Event

There are no events for this command.

Command

Table 27. MFC_AUTHENTICATE

Payload	Length (byte)	Value/Description
Command code	1	0x0B

Table 27. MFC_AUTHENTICATE...continued

Payload	Length (byte)	Value/Description
Parameter	6	Key Authentication key to be used.
	1	KeyType 0x60: Key Type A 0x61: Key Type B
	1	Block Address The address of the block for which the authentication has to be performed.
	4	UID UID of the card.
Response	1	Status 0x00 no error (Authentication successful) 0x01 error (Authentication failed) 0x02 Timeout waiting for card response (card not present). 0x07 Authentication error: Indicates that MFC authentication failed (permission denied)

9.22.15 Command EPC_GEN2_INVENTORY (0Ch)

This instruction is used to perform an inventory of ISO18000-3M3 tags. It implements an autonomous execution of several commands according to ISO18000-3M3 in order to guarantee the timings specified by that standard.

If present in payload of the instruction, first a "Select" command is executed followed by a "BeginRound" command. If there is a valid response in the first timeslot (no timeout, no collision), the instructions sends an ACK (acknowledge) and saves the received PC/XPC/ UII.

The instruction then performs an action according to the field 'Timeslot Processed Behavior':

- if this field is set to 0 a NextSlot command is issued to handle the next timeslot. This is repeated until the internal buffer is full
- If this field is set to 1 the algorithm pauses
- If this field is set to 2 a Req_Rn command is issued if, and only if, there has been a valid tag response in this timeslot command.

Conditions

The field 'Select Command Length' must contain the length of the field 'Select Command', which must be in the range from 1 – 39, inclusive. If 'Select Command Length' is 0, the fields 'Valid Bits in last Byte' and 'Select Command' must not be present.

The field Bits in last Byte should contain the number of bits to be transmitted in the last byte of the 'Select Command' field. The value must be in the range from 1 – 7, inclusive. If the value is 0, all bits from last byte from 'Select Command' field are transmitted. The field 'Select Command' should contain a *Select* command according to ISO18000-3M3 without trailing CRC-16c and must have the same length as indicated in field 'Select

Command Length'. Field 'BeginRound Command' should contain a *BeginRound* command according to ISO18000-3M3 without trailing CRC-5. The last 7 bits of the last byte of 'BeginRound Command' are ignored as the command has an actual length of 17 bits. 'Timeslot Processed Behavior' must contain a value from 0 – 2, inclusive.

Event

There are no events defined for this command.

Command

Table 28. EPC_GEN2_INVENTORY

Payload	Length (byte)	Value/Description
Command code	1	0x0C
Parameter	1	Resume Inventory: 00: Initial GEN2_INVENTORY 01: Resume the GEN2_INVENTORY command – the remaining fields below are empty (any payload is ignored)
	1	Select Command Length 0x00 No Select command is set prior to BeginRound command. 'Valid Bits in last Byte' field and 'Select command' field shall not be present. 0x01...0x27: Length (1d...39d) of the 'Select command' field.
	1	Valid Bits in last Byte 0: All bits of last byte of 'Select command' field are transmitted. 1-7: Number of bits to be transmitted in the last byte of 'Select command' field.
	0...39	If present, this field contains the Select command (according to ISO18000-3, Table 47) which is sent prior to BeginRound command. CRC-16c will not be included.
	3	BeginRound Command This field contains the BeginRound command (according to ISO18000-3, Table 49). CRC-5 will not be included
	1	Timeslot Processed Behavior 0x00: Response shall contain max. Number of timeslots which may fit in response buffer. 0x01: Response shall contain only one timeslot. 0x02: Response shall contain only one timeslot. If timeslot contains valid card response, also the card handle is included.
Response	1	Status 0x00 no error 0x01 syntax error (no further bytes)
	3-69	Timeslot array {Timeslot status element, Tag reply length element, Valid bits in last byte element}

Table 28. EPC_GEN2_INVENTORY...continued

Payload	Length (byte)	Value/Description
		1 Timeslot status element 0x00: Tag response available. 'Tag Reply Length' field, 'Valid bits in last byte' field, and 'Tag reply' field present. 0x01: Tag response available. 0x02: No tag replied in timeslot. 'Tag Reply Length' field and 'Valid bits in last byte' field, shall be set to zero. 'Tag reply' field shall not be present. 0x03: Two or more tags responded in the timeslot. (Collision). 'Tag Reply Length' field and 'Valid bits in last byte' field, shall be set to zero. 'Tag reply' field shall not be present.
		1 Tag Reply Length element 0x00...0x42: Length of 'Tag Reply' field [0d...66d]. If Tag Reply Length is 0x00, then the Tag Reply field is not present.
		1 Valid bits in last byte element 0: All bits of last byte of 'Tag reply' field are valid. 1: Number of valid bits of last byte of 'Tag reply' field. If Tag Reply Length is zero, the value of this byte shall be ignored.
	n	Tag Reply n-bytes reply of the tag according to ISO18000-3_2010, Table 56.
	0 or 2	Tag Handle 2 byte handle of the tag, in case field 'Timeslot Status' is set to '1'. Otherwise field not present

9.22.16 Command LOAD_RF_CONFIGURATION (0Dh)

Description

This instruction is used to load the RF configuration from E2PROM into registers. It is possible to configure RF technology, mode (target/initiator) and baud rate. Configurations can be loaded separately for the receiver (RX configuration) and transmitter (TX configuration). The value 0xFF has to be used if the existing configuration for either TX or RX shall not be updated.

Conditions

Field 'TX Configuration' must be in the range from 0x0 – 0x2B, inclusive. If the value is 0xFF, TX configuration is not changed.

Field 'RX Configuration' must be in the range from 0x80 – 0xAB, inclusive. If the value is 0xFF, RX configuration is not changed.

A special configuration with TX Configuration = 0xFF and RX Configuration = 0xAC is used load the Boot-up registers one time. This special configuration is required to update the register configurations (both TX and RX) that are different from the IC reset values.

Event

There are no events for this command.

Command

Table 29. LOAD_RF_CONFIGURATION

Payload	Length (byte)	Value/Description
Command code	1	0x0D
Parameter	1	TX Configuration (Transmitter) 0xFF: actual TX configuration not changed. others: Corresponding TX configuration loaded.
	1	RX Configuration (Receiver) 0xFF: actual RX configuration not changed. others: Corresponding RX configuration loaded.
Response	1	Status of the operation: 0x00 STATUS_SUCCESS 0x08 STATUS_MEMORY_ERROR 0x18 STATUS_INSTR_ERROR

9.22.16.1 Parameter for command LOAD_RF_CONFIGURATION

Table 30. TX Parameter for command LOAD_RF_CONFIGURATION

TX					
	Setting	Protocol	alternate	Speed	Modulation
PCD	0x00	ISO14443A	NFC-PI-106, NFC-AI-106	106	Miller
	0x01	ISO14443A	-	212	Miller
	0x02	ISO14443A	-	424	Miller
	0x03	ISO14443A	-	848	Miller
	0x04	ISO14443B	-	106	NRZ
	0x05	ISO14443B	-	212	NRZ
	0x06	ISO14443B	-	424	NRZ
	0x07	ISO14443B	-	848	NRZ
	0x08	FeliCa	NFC-PI-212, NFC-AI-212	212	
	0x09	FeliCa	NFC-PI-424, NFC-AI-424	424	
	0x0a	ISO15693_ASK100	-	26	1out4/ASK100
	0x0b	ISO15693_ASK10	-	26	1out4/ASK10
	0x0c	-	-	-	-
	0x0d	-	-	-	-
	0x0e	-	-	-	-
	0x0f	ISO180003m3	-	TARI=18_88us	ASK

Table 30. TX Parameter for command LOAD_RF_CONFIGURATION...continued

TX					
	Setting	Protocol	alternate	Speed	Modulation
	0x10	ISO180003m3	-	TARI=9_44us	ASK
	0x11	-	-	-	-
	0x12	-	-	-	-
PICC	0x13	ISO14443A-PICC	NFC-PT-106	106	Manch SubC
	0x14	ISO14443A-PICC	-	212	BPSK
	0x15	ISO14443A-PICC	-	424	BPSK
	0x16	ISO14443A-PICC	-	848	BPSK
	0x17	NFC-PT-212	-	212	-
	0x18	NFC-PT-424	-	424	-
	0x19	NFC-AT-106	-	106	-
	0x1a	NFC-AT-212	-	212	-
	0x1B	NFC-AT-424	-	424	-
	0x1C	GTM	-	All	All
	0x1D	Idle_RF_Config	-	All	-
	0x1E..0xFE	-	-	-	-
	0xFF	No change	-	-	-

Table 31. RX Parameter for command LOAD_RF_CONFIGURATION

RX					
	Setting	Protocol	alternate	Speed	Modulation
PCD	0x80	ISO14443A	NFC-PI-106, NFC-AI-106	106	Manch SubC
	0x81	ISO14443A	-	212	BPSK
	0x82	ISO14443A	-	424	BPSK
	0x83	ISO14443A	-	848	BPSK
	0x84	ISO14443B	-	106	BPSK
	0x85	ISO14443B	-	212	BPSK
	0x86	ISO14443B	-	424	BPSK
	0x87	ISO14443B	-	848	BPSK
	0x88	FeliCa	NFC-PI-212, NFC-AI-212	212	
	0x89	FeliCa	NFC-PI-424, NFC-AI-424	424	
	0x8a	ISO15693	-	6P6	Manch424
	0x8b	ISO15693	-	26	Manch424

Table 31. RX Parameter for command LOAD_RF_CONFIGURATION...continued

RX					
	0x8c	ISO15693	-	53	Manch424
	0x8d	ISO15693	-	106	-
	0x8e	ISO15693	-	212	-
	0x8f	ISO180003m3_ Manch424_4	-	106	Manch424/4 period
	0x90	ISO180003m3_ Manch424_2	-	212	Manch424/2 period
	0x91	ISO180003m3_ Manch848_4	-	212	Manch848/4 period
	0x92	ISO180003m3_ Manch848_2	-	424	Manch848/2 period
PICC	0x93	ISO14443A-PICC	NFC-PT-106	106	Miller
	0x94	ISO14443A-PICC	-	212	Miller
	0x95	ISO14443A-PICC	-	424	Miller
	0x96	ISO14443A-PICC	-	848	Miller
	0x97	NFC-PT-212	-	212	-
	0x98	NFC-PT-424	-	424	-
	0x99	NFC-AT-106	-	106	-
	0x9A	NFC-AT-212	-	212	-
	0x9B	NFC-AT-424	-	424	-
	0x9C	GTM	-	All	All
	0x9D	Idle_RF_Config	-	All	-
	0x9E	Boot	-	All	-
	0x9F-0xFE	-	-	-	-
	0xFF	no change	-	-	-

9.22.17 Command UPDATE_RF_CONFIGURATION (0Eh)

Description

This instruction is used to update the RF configuration within the EEPROM. The instruction allows updating at register granularity value, i.e. not the complete register set needs to be updated.

Conditions

The size of the field array must be in the range from 1 – n, inclusive. The field array 'Configuration' must contain a set of elements for 'RF Configuration', 'Register Address' and 'Value'. The field 'RF configuration' must be in the range from 0x00 – 0x2B for the TX configuration and 0x80 – 0xAB for the RX configuration, inclusive. The address within field 'Register Address' must exist within the respective RF configuration. Field 'Value' should contain a value which has to be written into the given register and must be 4 bytes long.

Event

There are no events for this command.

Command

Table 32. UPDATE_RF_CONFIGURATION

Payload	Length (byte)	Value/Description	
Command code	1	0x0E	
Parameter	n	Array of n { RF configuration element, Register address element, Value element }	
		1	RF configuration element RF Configuration for which the register has to be changed.
		1	Register address element Register Address within the given RF technology.
		4	Value element Value which has to be written into the register
Response	1	Status of the operation: 0x00 STATUS_SUCCESS 0x08 STATUS_MEMORY_ERROR 0x18 STATUS_INSTR_ERROR	

9.22.18 Command GET_RF_CONFIGURATION (0Fh)

Description

This instruction is used to read out an RF configuration. The register address-value-pairs are available in the response. In order to know how many pairs are to be expected, first size information can be retrieved from the first TLV, which indicates the total length of the payload.

Conditions

The field 'RF configuration' must be in the range from 0x0 – 0x2B for TX Configuration and 0x80 – 0xAB for the RX configuration, inclusive.

Event

There are no events for this command.

Command

Table 33. GET_RF_CONFIGURATION

Payload	Length (byte)	Value/Description
Command code	1	0x1F
Parameter	1	RF Configuration RF Configuration for which the set of register value pairs have to be retrieved.

Table 33. GET_RF_CONFIGURATION...continued

Payload	Length (byte)	Value/Description
Response	1	Status of the operation: 0x00 STATUS_SUCCESS 0x18 STATUS_INSTR_ERROR
	n * 5	Array of n { Register address element, Register value element }; n defined by first TLV
		1
	4	Register value element 32-Bit register data content.

9.22.19 Command RF_ON (10h)

Description

This instruction is used to activate the transmitter output.

The RF_ON command shall be always sent with a guard time of at least 5.1 ms after a previous RF_OFF command.

Conditions

The transmitter needs to be supplied to allow the emission of an RF field.

Event

There are no events for this command.

Command

Table 34. RF_ON

Payload	Length (byte)	Value/Description
Command code	1	0x10
Parameter	1	RF On Bit 0 = 0: Use collision avoidance by RF Level detector Bit 0 = 1: Disable collision avoidance by RF level detector Bit 1 = 0 No P2P active Bit 1 = 1 P2P active
Response	1	Status 0x00 no error (RF field switched on) 0x01 error (wrong payload of command) 0x02 RF Field not switched on due to detected RF collision.

9.22.20 Command RF_OFF (11h)

Description

This instruction is used to de-activate the transmitter output.

Conditions

No conditions are required to execute this command.

Event

There are no events for this command.

Command

Table 35. RF_OFF

Payload	Length (byte)	Value/Description
Command code	1	0x11
Parameter	0	No payload
Response	1	Status 0x00 no error (RF field switched off) 0x01 error (wrong payload of command)

9.22.21 Command CONFIGURE_TESTBUS_DIGITAL (12h)

Description

This instruction is used to route digital test bus signals to the available test buses TB0 (Testbus_0) and TB1 (Testbus_1).

Conditions

No conditions are required to execute this command.

Event

There are no events for this command.

Command

Table 36. RF_OFF

Payload	Length (byte)	Value/Description
Command code	1	0x12
Parameter	1	TB_SignalIndex
	1	TB_BitIndex
	1	TB_PadIndex
Response	1	Status 0x00 no error 0x018 Instruction error

9.22.22 Command CONFIGURE_TESTBUS_ANALOG (13h)

Description

This instruction is used activate analog debug signals to the available test signal out pads AUX1, AUX2.

Conditions

No conditions are required to execute this command.

If used, **ADC-Q needs to be routed always to AUX1, ADC-I needs to be routed always to AUX2**

Event

There are no events for this command.

Command

Table 37. RF_OFF

Payload	Length (byte)	Value/Description
Command code	1	0x12
Parameter	1	Config: Configurable bits
	1	Combined_Mode Signal: 0 – ADCI/ADCQ 1 – pcrn_if_rssi 2-0xFF – Reserved
	1	TB_SignalIndex0 Signal index of the analog signal
	1	TB_SignalIndex1 Signal index of the analog signal
	1	Shift_Index0 DAC0 input shift positions. Direction will be decided by bit_0 in Config
	1	Shift_Index1 DAC1 input shift positions. Direction will be decided by bit_1 in bConfig.
	1	Mask0: DAC0 mask
	1	Mask1: DAC1 mask
Response	1	Status 0x00 no error 0x018 Instruction error

9.22.23 Command CTS_ENABLE (14h)

Description

This instruction is used to enable/disable the CTS feature.

Conditions

-

Event

In case a trigger condition is fulfilled, an event will be raised:

Payload	Length (byte)	Value/Description
EVENT	1	00 ... TRIGGER has occurred, data is ready for reception.

Command

Table 38. CTS_ENABLE

Payload	Length (byte)	Value/Description
Command code	1	0x14
Parameter	1	Enable 0x00: Disable the CTS Logging Feature 0x01: Enable the CTS Logging Feature 0x02-0xFF: RFU
Response	1	0x00 no error 0x01 error

9.22.24 Command CTS_CONFIGURE (15h)**Description**

This instruction is used to configure the all the required CTS registers such as triggers, test bus registers, sampling configuration etc.

The captured data to be sent as part of the response to CTS_RETRIEVE_LOG command.

Event

There is no event for this instruction.

Command

Table 39. CTS_CONFIGURE

Payload	Length (byte)	Value/Description
Command code	1	0x15

Table 39. CTS_CONFIGURE ...continued

Payload	Length (byte)	Value/Description
Parameter	1	PRE_TRIGGER_SHIFT Defines the length of the after-trigger acquisition sequence in 256-bytes units. 0 means no shift; n means n*256 bytes block shift. Note: Valid only if TRIGGER_MODE is "PRE" or "COMB" trigger mode
	1	TRIGGER_MODE Specifies Acquisition mode to be used. 0x00 - POST mode 0x01 - RFU 0x02 - PRE Mode 0x03 - 0xFF - Invalid

Table 39. CTS_CONFIGURE ...continued

Payload	Length (byte)	Value/Description
	1	<p>RAM_PAGE_WIDTH</p> <p>Specifies the amount of on-chip memory that is covered by an acquisition. Granularity is chosen by design as 256 Bytes (i.e. 64 32-bits words).</p> <p>Valid values are as below:</p> <p>0x00h - 256 bytes 0x01h - 512 bytes 0x02h - 768 bytes 0x03h - 1024 bytes 0x04h - 1280 bytes 0x05h - 1536 bytes 0x06h - 1792 bytes 0x07h - 2048 bytes 0x08h - 2304 bytes 0x09h - 2560 bytes 0x0Ah - 2816 bytes 0x0Bh - 3072 bytes 0x0Ch - 3328 bytes 0x0Dh - 3584 bytes 0x0Eh - 3840 bytes 0x0Fh - 4096 bytes 0x10h - 4352 bytes 0x11h - 4608 bytes 0x12h - 4864 bytes 0x13h - 5120 bytes 0x14h - 5376 bytes 0x15h - 5632 bytes 0x16h - 5888 bytes 0x17h - 6144 bytes 0x18h - 6400 bytes 0x19h - 6656 bytes 0x1Ah - 6912 bytes 0x1Bh - 7168 bytes 0x1Ch - 7424 bytes 0x1Dh - 7680 bytes 0x1Eh - 7936 bytes 0x1Fh - 8192 bytes</p> <p>Note: if values provided is more than 0x1F, the value will be masked with 0x1F and resultant value will be considered.</p>

Table 39. CTS_CONFIGURE ...continued

Payload	Length (byte)	Value/Description
	1	<p>SAMPLE_CLK_DIV</p> <p>The decimal value of this field specifies the clock rate division factor to be used during acquisition. CTS clock = 13.56 MHz / $2^{\text{SAMPLE_CLK_DIV}}$</p> <p>00 - 13560 kHz 01 - 6780 kHz 02 - 3390 kHz 03 - 1695 kHz 04 - 847.5 kHz 05 - 423.75 kHz 06 - 211.875 kHz 07 - 105.9375 kHz 08 - 52.96875 kHz 09 - 26.484375 kHz 10 - 13.2421875 kHz 11 - 6.62109375 kHz 12 - 3.310546875 kHz 13 - 1.6552734375 kHz 14 - 0.82763671875 kHz 15 - 0.413818359375 kHz</p>
	1	<p>SAMPLE_BYTE_SEL</p> <p>These bits are used to specify which bytes of the two 16-bits input buses contribute to the interleave mechanism that generates data to be transferred to the on-chip memory. The meaning and usage of them is depending from the SAMPLE_MODE_SEL values.</p> <p>Note: Given value is always masked with 0x0F and then effective value is considered.</p>
	1	<p>SAMPLE_MODE_SEL</p> <p>Selects the sampling interleave mode as described by the CTS design specs. Decimal value 3 is reserved and will be treated as 0. Note: Given value is always masked with 0x03, and then effective value is considered.</p>
	1	<p>TB0</p> <p>Selects which test bus to be connected to TB0. Refer to list below (TB_Signal_Index value)</p>
	1	<p>TB1</p> <p>Selects which test bus to be connected to TB1. Refer to list below (TB_Signal_Index value)</p>
	1	<p>TB2</p> <p>Selects which test bus to be connected to TB2. Refer to list below (TB_Signal_Index value)</p>
	1	<p>TB3</p> <p>Selects which test bus to be connected to TB3. Refer to list below (TB_Signal_Index value)</p>

Table 39. CTS_CONFIGURE ...continued

Payload	Length (byte)	Value/Description
	1	TTB_SELECT Selects which TB to be connected to the trigger sources. Refer to list below (TB_Signal_Index value)
	4	RFU Send always 0x00000000
	24	MISC_CONFIG Trigger occurrences, polarity etc. Refer to (5) below for understanding of CTS configuration to use.
Response	1	0x00 no error 0x01 error

9.22.25 Command CTS_RETRIEVE_LOG (16h)

Description

This instruction retrieves the data log of the captured test bus data samples stored in the memory buffer.

CTS_RETRIEVE_LOG is valid only if CTS_EVENT bit is set in the EVENT_STATUS register.

Event

There are no events for this command.

Command

Table 40. CTS_RETRIEVE_LOG

Payload	Length (byte)	Value/Description
Command code	1	0x16
Parameter	1	ChunkSize 0x01-0xFF Contains the number of bytes of data expected.
Response	1	Status of the operation Expected values: - STATUS_SUCCESS - STATUS_INSTR_ERROR (No further data is present) - STATUS_SUCCSES_CHAINING
	1..n	CTSRequest Captured Samples Data chunk. Maximum size is depended upon the 'ChunkSize' that has been provided as part of the command. Total ChunkSize shall be available in the TLV header response.

9.22.26 Command RECEIVE_RF_DATA (1Ah)

Description

This instruction waits for the command/data from the reader to be received. The instruction returns in case of a reception (either erroneous or correct) and is blocking or a timeout occurred. The timer is started with the END of TRANSMISSION and stopped with the START of RECEPTION. The default timeout value preconfigured in EEPROM shall be used.

Conditions

This instruction is valid only in “Card” mode or “Target” mode.

Error conditions for the reception are available in the register RX_STATUS_REG.

Event

There are no events for this command.

Command

Table 41. RECEIVE_RF_DATA

Payload	Length (byte)	Value/Description	
Command code	1	0x1A	
Parameter	1	7..4: RFU	
		3: Include RX Data in response based on RX_STATUS, if bit set	
		2: Include EVENT_STATUS register in response, if bit set	
		1: Include RF_STATUS register in response, if bit is set	
		0: Include RX_STATUS register in response, if bit is set	
Response	1	Status of the operation: 0x00: PN5190B1_STATUS_INSTR_SUCCESS 0x01: PN5190B1_STATUS_TIMEOUT 0x0A: PN5190B1_STATUS_NO_RF_FIELD 0x10: PN5190B1_STATUS_NO_EXTERNAL_RF_FIELD 0x18: PN5190B1_STATUS_INSTR_ERROR (No further data is present)	
		4	If RX_STATUS is requested (little endian)
		4	If RF_STATUS is requested (little endian)
		4	If EVENT_STATUS is requested (little endian)
		1-1024	RX data which has been received during last successful RF reception.

9.22.27 Command SWITCH_MODE_NORMAL (20h)

Description

The Switch Mode Normal command is used to terminate one of the modes Standby, LPCD (not ULPCD) or Autocoll. The response indicates that the normal mode is entered.

Conditions

-

Event

Table 42. EVT_SWITCH_MODE_NORMAL

Payload	Length (byte)	Value/Description
Event	1	Indicates that the normal mode is entered and PN5190B1 is able to receive new commands.

Command

Table 43. SWITCH_MODE_NORMAL

Payload	Length (byte)	Value/Description
Command code	1	0x20
Parameter	0	- (no payload)
Response	0	- (No data in response. Instead the EVT_SWITCH_MODE_NORMAL is used to indicate the successful operation mode-switch)

9.22.28 Command SWITCH_MODE_AUTOCOLL (21h)**Description**

The Switch Mode Autocoll automatically performs the card activation procedure in target mode.

Conditions

In case field 'Mode' is set to 2 (Autocoll): Field 'RF Technologies' (Table 21) must contain a bitmask indicating the RF Technologies to support during Autocoll, according to Table 22.

Field 'Autocoll Mode' must be in the range from 0 – 2, inclusive.

No instructions must be sent while being in this mode.

Termination of the command is indicated by an interrupt.

Event

The event notification is sent when the command has terminated and the normal mode is entered. Host shall read-out the response bytes based on the event value. Technology information is retrieved from the registers using the command READ_REGISTER or READ_REGISTER_MULTIPLE.

Command

Table 44. EVT_SWITCH_MODE_AUTOCOLL

Payload	Length (byte)	Value/Description
Event	1	0X00 ... PN5190B1 has been activated as a card 0X01 ... No RF field or RF field has vanished

Table 44. EVT_SWITCH_MODE_AUTOCOLL...continued

Payload	Length (byte)	Value/Description
Autocoll_resp	0...n	0 ... if previous field is 01 1..n bytes ATR_RES / ATS_RES as per ISO18092 / ISO1443-4

Table 45. SWITCH_MODE_AUTOCOLL

Payload	Length (byte)	Value/Description
Command code	1	0x21
Parameter	1	RF Technologies: Bitmask indicating the RF technology to listen for during Autocoll.
	1	Autocoll Mode 0x00: Autonomous mode not used i.e. Autocoll terminates when external RF field is not present. Termination in case of • NO RF FIELD or RF FIELD has disappeared • PN5190B1 is ACTIVATED in TARGET mode
		0x01 Autonomous mode used. When no RF field is present, Autocoll automatically enters standby mode. Once RF external RF field is detected, PN5190B1 enters again Autocoll mode. Termination in case of • PN5190B1 is ACTIVATED in TARGET mode
0x02 Autonomous mode without standby used. When no RF field is present, PN5190B1 waits until RF field is present before actually starting Autocoll algorithm. Standby is not used in this case. Termination in case of • PN5190B1 is ACTIVATED in TARGET mode		
Response	1	Status 0x00 no error 0x01 error (Switch mode has not been entered – due to wrong settings or due to standby prevention)

Table 46. RF Technologies parameter: Bitmask

Bitmask / Bit position								Description
B7	B6	B5	B4	B3	B2	B1	B0	
0	0	0	0					RFU
				X				listening for NFC-F Active is enabled
					X			listening for NFC-A Active is enabled
						X		listening for NFC-F is enabled
							X	listening for NFC-A is enabled

9.22.29 Command SWITCH_MODE_STANDBY (22h)

Description

The Switch Mode Standby automatically sets the IC into standby mode.

Conditions

-

Event

The event notification is sent when the command has finished and the normal mode is entered.

Command

Table 47. EVT_SWITCH_MODE_STANDBY

Payload	Length (byte)	Value/Description
Event	1	Indicates wake-up source 0x01 ... WUC 0x02 ... RF Level Detector 0x03 ... NSS low transition (HOSTIF activity)

Table 48. SWITCH_MODE_STANDBY

Payload	Length (byte)	Value/Description
Command code	1	0x22
Parameter	1	Wake-up Control Bitmask controlling the wake-up source to be used.
	2	Counter Value Used value for wake-up counter in msecs. Maximum supported value is 2690
Response	1	Status 0x00 no error 0x01 error (Switch mode has not been entered – due to wrong settings or due to standby prevention)

Table 49. STANDBY control parameter: Bitmask

Bitmask / Bit position								Description
B7	B6	B5	B4	B3	B2	B1	B0	
0	0	0	0	0	0			RFU
						X		Wake-up on external RF field
							X	Wake-up on wake-up counter expired

9.22.30 Command SWITCH_MODE_LPCD (23h)

Description

The Switch Mode LPCD performs a detuning detection on the antenna due to changing environment around the antenna. There are 2 different modes of LPCD. The HW-based solution offers a competitive power consumption with a reduced sensitivity. The FW-based solution offers a higher sensitivity at the cost of a slightly increased power consumption. The configuration of the LPCD is done in the EEPROM register settings before the command is called.

Conditions

Before this command is issued, other configuration bits must be specified.

Event

The event notification is sent when the command has finished and the normal mode is entered.

Command

Table 50. EVT_SWITCH_MODE_LPCD

Payload	Length (byte)	Value/Description
Event	1	0x00: LPCD has detected a wake-up condition

Table 51. SWITCH_MODE_LPCD

Payload	Length (byte)	Value/Description
Command code	1	0x 23
Parameter	1	LPCD Type 0x00 Hardware-based ULPCD is used 0x01 Firmware-based LPCD is used 0x02-0xFF RFU
	2	Counter Value Used value for wake-up counter in msec. Maximum supported value is 4096 (12 Bit), the counter input clock is 1 kHz
Response	1	Status 0x00 no error 0x01 error (Switch mode has not been entered – due to wrong settings)

9.22.31 Command SWITCH_MODE_DOWNLOAD (25h)**Description**

The Switch Mode Download command enters the Firmware download mode.

Conditions

The response signals that the command has been processed by the PN5190B1. After the response is read by the host and no error is indicated in the response, the download mode is entered.

Event

-

Command

Table 52. SWITCH_MODE_DOWNLOAD

Payload	Length (byte)	Value/Description
Command code	1	0x25
Parameter	0	- (SWITCH_MODE_DOWNLOAD command is called without any parameter)
Response	1	Status 0x00 no error 0x01 error (Switch mode has not been entered)

9.22.32 Command GET_DIE_ID (26h)

Description

This instruction is used to read-out the Die ID of the PN5190B1 chip.

Conditions

No conditions are required to execute this command.

Event

There are no events for this command.

Command

Table 53. GET_DIE_ID

Payload	Length (byte)	Value/Description
Command code	1	0x26
Parameter	0	No payload
Response	1	Status of the operation: 0x00: PN5190B1_STATUS_INSTR_SUCCESS 0x18: PN5190B1_STATUS_INSTR_ERROR (No further data is present)
	16	16 bytes DIE ID.

9.22.33 Command GET_VERSION (27h)

Description

This instruction is used to read-out the HW version, ROM version and the FW version of the PN5190B1 chip.

Conditions

No conditions are required to execute this command.

Event

There are no events for this command.

Command

Table 54. GET_VERSION

Payload	Length (byte)	Value/Description
Command code	1	0x27
Parameter	0	No payload
Response	1	Status of the operation: 0x00: PN5190B1_STATUS_INSTR_SUCCESS 0x18: PN5190B1_STATUS_INSTR_ERROR (No further data is present)
	1	Hardware Version
	1	ROM Code Version
	2	Firmware version (used for secure firmware download)

Example:

Get Version with FW v2.0

[HOST] -> [0x00 0x04 0xE1 0x00 0x00 0x00 0x75 0x48]

[HOST] <- [0x00 0x08 STAT HW_V RO_V MODEL_ID FM1V FM2V RFU1 RFU2 CRC16]

o/p : 00 08 00 51 02 00 00 02 00 00 7F 10

HW_Version = x51, ROM_Version = x02, MODEL_ID = x00, FirmwareVersion = 02.00

9.22.34 Command PRBS_TEST (41h)

Description

This instruction is used to generate the PRBS sequence for the different configurations of the reader mode protocols and bit-rates.

Conditions

This instruction is a blocking instruction and shall be terminated only with SWITCH_MODE_NORMAL command.

Event

There are no events for this command.

Command

Table 55. PRBS_TEST

Payload	Length (byte)	Value/Description
Command code	1	0x41
Parameter	1	prbs_type 0x00: PRBS9 (default) 0x01: PRBS15 0x02-0xFF: RFU
	1	prbs_techno 0x00: ISO14443-A 0x01: ISO1443-B 0x02: FeliCa 0x03: ISO15693 0x04-0xFF: RFU
	1	prbs_baud 0x00: 106 kBit/s (default for type A,B,F) 0x01: 212 kBit/s 0x02: 424 kBit/s 0x03: 848 kBit/s 0x04: 26 kBit/s (default for ISO15693) 0x05-0xFF: RFU
	2	prbs_length 2 bytes indicating the prbs length of 1 byte up to 510 bytes data length of the transmission sequence
Response	1	Status of the operation: 0x00: PN5190B1_STATUS_INSTR_SUCCESS 0x0A: PN5190B1_STATUS_NO_RF_FIELD 0x18: PN5190B1_STATUS_INSTR_ERROR (No further data is present)

9.22.35 RESPONSE STATUS CODES

Table 56. RESPONSE STATUS CODES LIST

RESPONSE STATUS	VALUE	Value/Description
STATUS_SUCCESS	0x00	Indicates that operation completed successfully
STATUS_TIMEOUT	0x01	Indicates that the operation of the command resulted in timeout
STATUS_INTEGRITY_ERROR	0x02	Indicates that the operation of the command resulted in RF data integrity error
STATUS_RF_COLLISION_ERROR	0x03	Indicates that the operation of the command resulted in RF collision error
STATUS_RFU1	0x04	-
STATUS_INVALID_COMMAND	0x05	Indicates that the given command is invalid/not implemented

Table 56. RESPONSE STATUS CODES LIST...continued

RESPONSE STATUS	VALUE	Value/Description
STATUS_RFU2	0x06	-
STATUS_AUTH_ERROR	0x07	Indicates that MFC authentication failed (permission denied)
STATUS_MEMORY_ERROR	0x08	Indicates that the operation of the command resulted in a programming error or internal memory error
STATUS_RFU4	0x09	-
STATUS_NO_RF_FIELD	0x0A	Indicates that there are no or error in internal RF field presence (applicable only if initiator/reader mode).
STATUS_RFU5	0x0B	-
STATUS_SYNTAX_ERROR	0x0C	Indicates that invalid command frame length is received
STATUS_RESOURCE_ERROR	0x0D	Indicates that an internal resource error occurred
STATUS_RFU6	0x0E	-
STATUS_RFU7	0x0F	-
STATUS_NO_EXTERNAL_RF_FIELD	0x10	Indicates that no external RF field is present during the execution of the command (Applicable only in card/target mode)
STATUS_RFU8	0x11	-
STATUS_USER_CANCELLED	0x12	Indicates that the present command in-progress is aborted
STATUS_PREVENT_STANDBY	0x13	Indicates that chip is prevented to go into standby mode
STATUS_RFU9	0x14	-
STATUS_CLOCK_ERROR	0x15	Indicates that clock to the CLIF did not start
STATUS_RFU10	0x16	-
STATUS_PRBS_ERROR	0x17	Indicates that the PRBS command returned an error
STATUS_INSTR_ERROR	0x18	Indicates that operation of the command is failed (it may include, the error in instruction parameters, syntax error, error in operation itself, pre-requirements for the instruction is not met etc....)
STATUS_ACCESS_DENIED	0x19	Indicates that access to internal memory is denied
STATUS_TX_FAILURE	0x1A	Indicates that TX over RF is failed
STATUS_NO_ANTENNA	0x1B	Indicates that no antenna is connected/present
RFU	0x1C-0x7E	-
STATUS_INTERNAL_ERROR	0x7F	Indicates that the NVM operation failed
RFU	0x80-0xAE	-
STATUS_SUCCSES_CHAINING	0xAF	Indicates that furthermore data is pending to be read

9.22.36 EVENTS INDICATED BY INTERRUPT

Normal events are indicated over IRQ.

These normal events can be either

- always enabled - Host is always notified
- controlled by Host – Host is notified if the respective Event Enable bit is set in the register (EVENT_ENABLE).

Low-level interrupts from the peripheral IPs including the CLIF are completely handled within the firmware and host will be notified only of the events listed in the events section.

The Firmware implements two event registers as RAM registers that can be written / Read using WRITE_REGISTER / READ_REGISTER commands.

Two registers do exist to handle the events from a host microcontroller: EVENT_ENABLE and EVENT_STATUS:

- EVENT_ENABLE => register, enables/disables specific event notifications
- EVENT_STATUS => content of this register is part of the event message payload

Events are auto-cleared once the event message is read-out by the host.

Events are asynchronous in nature and are notified to the host if they are enabled within event register.

Following is the list of events available to the host as part of event message:

Table 57. IRQ EVENT LIST

BIT	EVENT	Always enabled	Value/Description
31..12	RFU	-	-
11	CTS_EVENT	N	
10	IDLE_EVENT	Y	
9	LP_CALIBRATION_EVENT	N	
8	LPCD_EVENT	Y	
7	AUTOCOLL_EVENT	Y	
6	TIMER0_EVENT	N	
5	TX_OVERCURRENT_EVENT	N	
4	RFON_DET_EVENT	N	
3	RFOFF_DET_EVENT	N	
2	STANDBY_PREV_EVENT	Y	
1	GENERAL_ERROR_EVENT	Y	
0	BOOT_EVENT	Y	

Note that no two events are clubbed except in case of errors. In case of errors during the operation, functional event (e.g. BOOT_EVENT, AUTOCALL_EVENT etc.) and GENERAL_ERROR_EVENT will be set.

9.22.37 EVENTS INDICATED ON GPIO

Temperature events are possible to be indicated by a GPIO to speed up the notification to a host.

The EEPROM register ENABLE_GPIO0_ON_OVERTEMP (0054h) allows enabling the indication of a temperature event on GPIO0.

No other event can be routed to a GPIO.

9.23 Register description

The default setting of a bit within a register is indicated by the "*". Value indicates the allowed range for the bits of a symbol.

9.23.1 Register overview

Table 58. Register Overview

Address (HEX)	Address (decimal)	Name
0h	0	SYSTEM_CONFIG
1h	1	EVENT_ENABLE
2h	2	EVENT_STATUS
3h	3	EMVCO_EMD_CONTROL
4h	4	FELICA_EMD_CONTROL
5h	5	RX_STATUS
6h	6	RX_STATUS_ERROR
7h	7	CLIF_STATUS
8h	8	TRANSCEIVE_CONTROL
9h	9	TX_SYMBOL01_MOD
Ah	10	TX_SYMBOL1_DEF
Bh	11	TX_SYMBOL0_DEF
Ch	12	TX_SYMBOL23_MOD
Dh	13	TX_SYMBOL23_DEF
Eh	14	TX_SYMBOL_CONFIG
Fh	15	TX_FRAME_CONFIG
10h	16	TX_DATA_MOD
11h	17	TX_WAIT
12h	18	TX_CRC_CONFIG
13h	19	RFU
14h	20	RFU
15h	21	SS_TX_CONFIG
16h	22	SS_TX1_RMCFG
17h	23	SS_TX2_RMCFG

Table 58. Register Overview...continued

Address (HEX)	Address (decimal)	Name
18h	24	RFU
19h	25	SS_TX_TRANS_CFG
1A-1C	26-28	RFU
1D	29	PUBLIC RESERVED
1E	30	RFU
1F	31	PUBLIC_RESERVED
20	32	SIGPRO_RM_PATTERN
21	33	PUBLIC RESERVED
22	34	RFU
23-24	35-36	PUBLIC RESERVED
25	37	RFU
26	38	RX_FRAME_LENGTH
27	39	RX_ERROR_CONFIG
28	40	RX_CTRL_STATUS
29	41	PUBLIC RESERVED
2A	42	SIGPRO_IIR_CONFIG0
2B-2C	43-44	PUBLIC RESERVED
2Dh	45	RFU
2E	46	PUBLIC RESERVED
2Fh	47	RFU
30h	48	DGRM_RSSI
31h	49	RX_CRC_CONFIG
32h	50	RX_WAIT
33	51	PUBLIC RESERVED
34	52	RFU
35	53	RXM_CTRL
36	54	PUBLIC RESERVED
37	55	RFU
38-3A	56-58	PUBLIC RESERVED
3B	59	SS_TX1_CMCFG
3C	60	SS_TX2_CMCFG
3Dh	61	TIMER0_CONFIG
3Eh	62	TIMER0_RELOAD
3Fh	63	RFU
40h	64	RFU
41h-42h	65-66	RFU

Table 58. Register Overview...continued

Address (HEX)	Address (decimal)	Name
43	67	PUBLIC RESERVED
44-46	68-70	RFU
47h	71	EMD_1_CONFIG
48h	72	EMD_0_CONFIG
49-4F	73-79	RFU
50	80	LPCD_CALIBRATE_CTRL
51	81	IQ_CHANNEL_VALS
52	82	PAD_CONFIG
53	83	CALIBRATE_STATUS
54	84	TXLDO_VDDPA_CONFIG
55	85	GENERAL_ERROR_STATUS
56	86	TXLDO_VOUT_CURR
57	87	CLIF_DAC
58	88	PMU_ANA_SMPS_CTRL_REG
59	89	RXM_FREQ
5A	90	RXM_RSSI
5B	91	TEMP_SENSOR
5D	93	TX_NOV_CALIBRATE
80	128	SS_TX1_RTRANS0
81	129	SS_TX1_RTRANS1
82	130	SS_TX1_RTRANS2
83	131	SS_TX1_RTRANS3
84	132	SS_TX1_RTRANS4
85	133	SS_TX1_RTRANS5
86	134	SS_TX1_RTRANS6
87	135	SS_TX1_RTRANS7
88	136	SS_TX1_RTRANS8
89	137	SS_TX1_RTRANS9
8A	138	SS_TX1_RTRANS10
8B	139	SS_TX1_RTRANS11
8C	140	SS_TX1_RTRANS12
8D	141	SS_TX1_RTRANS13
8E	142	SS_TX1_RTRANS14
8F	143	SS_TX1_RTRANS15

9.23.2 SYSTEM_CONFIG (0000h)

Table 59. SYSTEM_CONFIG register (address 0000h) bit description

Bit	Symbol	Access	Value	Description
31:9	RFU	r/w	0*,1	-
8	TX_NOV_CALIBRATION	r/w	0*,1	One time calibration when the host writes a 1 into this register, a one time calibration will be performed. Note: The calibration is resulting a short RF-on. All the power configurations shall the configured before setting this bit.
7	RFU	r/w	0	-
6:5	15693_CHANGE_DATARATE	r/w	0*,1	15693_changedatarate 0 - RFU 1 - Change Data Rate to 53kB/sec 2 - Change Data Rate to 106kB/sec 3 - Change Data Rate to 212kB/sec By default, the basic data rate of 26kB/sec will be loaded, switching to a different higher data rate requires this config register to be updated. All relevant related registers will be updated automatically.
4	RFU	r/w	0*,1	-
3	AUTOCOLL STATE A	r/w	0*,1	0: TypeA Card mode: Autocoll entry with IDLE state of the card 1: TypeA Card mode: Autocoll entry with HALT state of the card
2	SOFT RESET	r/w	0*,1	Performs a soft reset of the system, all registers are set to default values
1	MF CRYPTO ON	r/w	0*,1	If set to 1 the MIFARE - crypto bit is generated for MIFARE Classic en-/de-cryption
0	RFU	r/w	0*,1	-

9.23.3 EVENT_ENABLE (0001h)

Table 60. EVENT_ENABLE register (address 0001h) bit description

Bit	Symbol	Access	Value	Description
31:8	RFU	r	0*,1	-
11	CTS_EVENT_ENABLE			Enable the corresponding event
10	IDLE_EVENT_ENABLE			Enable the corresponding event
9	LP_CALIBRATION_EVENT_ENABLE			Enable the corresponding event
8	LPCD_EVENT_ENABLE			Enable the corresponding event
7	AUTOCOLL_EVENT_ENABLE	r/w	0*,1	Enable the corresponding event
6	TIMER0_EVENT_ENABLE	r/w	0*,1	Enable the corresponding event
5	TEMP_ERROR_EVENT_ENABLE	r/w	0*,1	Enable the corresponding event

Table 60. EVENT_ENABLE register (address 0001h) bit description...continued

Bit	Symbol	Access	Value	Description
4	RFON_DET_EVENT_ENABLE	r/w	0*,1	Enable the corresponding event
3	RFOFF_DET_EVENT_ENABLE	r/w	0*,1	Enable the corresponding event
2	STANDBY_PREV_EVENT_ENABLE	r/w	0*,1	Enable the corresponding event
1	GENERAL_ERROR_EVENT_ENABLE	r/w	0*,1	Enable the corresponding event
0	BOOT_EVENT_ENABLE	r/w	0*,1	Enable the corresponding event

9.23.4 EVENT_STATUS (0002h)

Table 61. EVENT_STATUS register (address 0002h) bit description

Bit	Symbol	Access	Value	Description
31:12	RFU	r	0*,1	-
11	CTS_EVENT			Indicated the availability of CTS Event
10	IDLE_EVENT			Indicated the availability of IDLE event.
9	LP_CALIBRATION_EVENT			Indicated the availability of LP Calibration event
8	LPCD_EVENT			Indicated the availability of LPCD event.
7	AUTOCOLL_EVENT	r/w	0*,1	Indicated the availability of Autocoll event
6	TIMER0_EVENT	r/w	0*,1	Indicated the availability of Timer0 event
5	TEMP_ERROR_EVENT	r/w	0*,1	Indicated the availability of Temp error
4	RFON_DET_EVENT	r/w	0*,1	Indicated the availability of RF ON detected.
3	RFOFF_DET_EVENT	r/w	0*,1	Indicated the availability of Standby Prevention reason.
2	STANDBY_PREV_EVENT	r/w	0*,1	Indicated the availability of Standby Prevention reason.
1	GENERAL_ERROR_EVENT	r/w	0*,1	Indicated the availability of General Error event.
0	BOOT_EVENT	r/w	0*,1	Indicated the availability of Boot event.

9.23.5 EMVCO_EMD_CONTROL (0003h)

To activate the EMVCo EMD handling of the PN5190B1, the following bits of the register need to be set as follows:

0001b: EMVCO_EMD_ENABLE

1b: EMD_TRANSMISSION_ERROR_ABOVE_NOISE_THRESHOLD_IS_NO_EMD

0001b: EMD_NOISE_BYTES_THRESHOLD

Table 62. EMVCO_EMD_CONTROL register (address 0003h) bit description

Bit	Symbol	Access	Value	Description
31:12	RFU	rw	0*,1	-

Table 62. EMVCO_EMD_CONTROL register (address 0003h) bit description...continued

Bit	Symbol	Access	Value	Description
11:10	EMD_RM_EMD_SENSITIVITY	rw	0*,1	RM EMD SENSITIVITY value that will be applied to SIGPRO_RM_CONFIG, At layer 4, when EMD is enabled, the value of EMD_RM_SENSITIVITY can be lowered to ensure robust EMD suppression, if during the layer 3 activation, the value of EMD_RM_SENSITIVITY in the protocol area is set to a high value to ensure collision detection and resolution when multiple typeA cards are presented at close distance to the antenna.
9:8	EMD_TRANSMISSION_TIMER_USED	rw	0*,1	Timer used for RF communication.
7	EMD_MISSING_CRC_IS_PROTOCOL_ERROR_TYPE_B	rw	0*,1	Missing CRC treated as protocol error in » case of Type B based communication P » case of Type B based communication
6	EMD_MISSING_CRC_IS_PROTOCOL_ERROR_TYPE_A	rw	0*,1	Missing CRC treated as protocol error in » case of Type A based communication P » case of Type A based communication
5:2	EMD_NOISE_BYTES_THRESHOLD	rw	0*,1	Defines the threshold under which transmission errors are treated as noise. Note: CRC bytes are NOT included/counted!
1	EMD_TRANSMISSION_ERROR_ABOVE_NOISE_THRESHOLD_IS_NO_EMD	rw	0*,1	Transmission errors with received byte length >= EMD_NOISE_BYTES_THRESHOLD is never treated as EMD (can be used for versions below EMVCo3.0)
0	EMVCO_EMD_ENABLE	rw	0*,1	EMD handling enabled If this register is enabled by setting EMVCO_EMD_ENABLE=1, the registers EMD_0_CONFIG and EMD_1_CONFIG is ignored for the EMVCO_EMD function.

9.23.6 FELICA_EMD_CONTROL (0004h)

Table 63. FELICA_EMD_CONTROL register (address 0004h) bit description

Bit	Symbol	Access	setting for FeliCa EMD handling	Value	Description
31:24	FELICA_EMD_RC_BYTE_VALUE	rw	0	0*,1	FeliCa RC byte value that needs to be received does not treat the frame as EMD
23:16	FELICA_EMD_LENGTH_BYTE_MAX	rw	0	0*,1	Maximum Length byte value that needs to be received does not treat the frame as EMD
15:8	FELICA_EMD_LENGTH_BYTE_MIN	rw	0	0*,1	Minimum Length byte value that needs to be received does not treat the frame as EMD
7:5	RESERVED	rw	0	0*,1	-

Table 63. FELICA_EMD_CONTROL register (address 0004h) bit description...continued

Bit	Symbol	Access	setting for FeliCa EMD handling	Value	Description
4	FELICA_EMD_INTEGRITY_ERR_CHECK_ENABLE	rw	1	0*,1	FeliCa EMD handling enabled when integrity error is set
3	FELICA_EMD_PROTOCOL_ERR_CHECK_ENABLE	rw	1	0*,1	FeliCa EMD handling enabled when protocol error is set
2	FELICA_EMD_RC_CHECK_ENABLE	rw	0	0*,1	FeliCa RC byte check enabled for FeliCa EMD handling
1	FELICA_EMD_LEN_CHECK_ENABLE	rw	0	0*,1	FeliCa Length byte check enabled for FeliCa EMD handling
0	FELICA_EMD_ENABLE	rw	1	0*,1	FeliCa EMD handling enabled

Recommended value for FeliCa EMD handling: 00FF0019h

9.23.7 RX_STATUS (0005h)

Table 64. RX_STATUS register (address 0005h) bit description

Bit	Symbol	Access	Value	Description
31:27	RFU	r	0*,1	-
26:20	RX_COLL_POS	r	0*,1	Status indicating the bit position of the first collision detected in the data bit. The value is valid only when RX_COLLISION_DETECTED==1. The value of the RX_BIT_ALIGN is also taken into account (RX_COLL_POS = physical bit position in the flow + RX_BIT_ALIGN value). Indicates the collision position in the first 8 bytes only. Can be used during the TypeA/ICODE/EPC anti-collision procedure. 0x00 - first bit 0x01 - second bit...0x7F - 128th bit. The status register is not updated by the collision detected on stop or parity bit.
19:17	RX_NUM_LAST_BITS	r	0*,1	Indicating the number of valid bits in the last byte received. 0: all bits are valid 1: 1 bit is valid 7: - 7 bits are valid This is generally used during ISO/IEC14443 type A anti-collision
16:13	RX_NUM_FRAMES_RECEIVED	r	0*,1	Indicates the number of frames received. The value is updated after every normal frame reception in RX_MULTIPLE mode. The value is valid only if the bit RX_MULTIPLE_ENABLE=='1'.
12:0	RX_NUM_BYTES_RECEIVED	r	0*,1	Number of bytes received on the RF interface

9.23.8 RX_STATUS_ERROR (0006h)

Table 65. RX_STATUS_ERROR register (address 0006h) bit description

Bit	Symbol	Access	Value	Description
31:30	RFU	r	0*,1	
29	EMD_DETECTED_IN_RXDEC	r/w	0*,1	The high level indicates that the EMD was detected (in the SigPro or in the RxDecoder or in both) during the reception.
28	EMD_DETECTED_IN_SIGPRO	r/w	0*,1	The high level indicates that the EMD was detected on the Physical layer (in the SigPro) during the reception.
27	EXT_RFOFF_DETECTED	r/w	0*,1	The high level indicates that the received frame length violated the configured minimum limit.
26	RX_FRAME_MAXLEN_VIOL	r/w	0*,1	The high level indicates that the received frame length is less or equal to the expected CRC field length.
25	RX_FRAME_MINLEN_VIOL	r/w	0*,1	The high level indicates that the last received character in the frame has less than 8 bits.
24	RX_FRAME_LE_CRC	r/w	0*,1	The high level indicates that the last received character in the frame has 8 data bits but the expected parity bit is absent.
23	RX_NOT_FULL_BYTE	r/w	0*,1	The high level indicates that the last received character in the frame has 8 data bits but the expected stop bit is absent.
22	RX_MISSING_PARBIT_DETECTED	r/w	0*,1	The high level indicates that the collision was detected on the parity bit position.
21	RX_MISSING_STOPBIT_DETECTED	r/w	0*,1	The high level indicates that the collision was detected on the stop bit position.
20	RX_COLLISION_PARBIT_DETECTED	r/w	0*,1	The high level indicates that the collision was detected during the frame reception.
19	RX_COLLISION_STOPBIT_DETECTED	r/w	0*,1	The high level indicates that the frame reception was stopped by SGP_MSG_RXOVER_* message reception.
18	RX_COLLISION_DETECTED	r/w	0*,1	The high level indicates that the collision was detected during the frame reception.
17	RX_STOP_ON_RXOVER	r/w	0*,1	The high level indicates that the frame reception was stopped by SGP_MSG_RXOVER_* message reception.
16	RX_STOP_ON_RFOFF	r/w	0*,1	The high level indicates that the frame reception was interrupted by external RF-field vanishing event.
15	RX_STOP_ON_ERR	r/w	0*,1	The high level indicates that the frame reception was stopped by detected communication error event.
14	RX_STOP_ON_LEN	r/w	0*,1	The high level indicates that the frame reception was normally stopped by byte counter expiration event. Relates to the protocols where the LEN field is used in the frame format (FeliCa RM/CM, FWEC RM/CM).

Table 65. RX_STATUS_ERROR register (address 0006h) bit description...continued

Bit	Symbol	Access	Value	Description
13	RX_STOP_ON_INVPAR	r/w	0*,1	The high level indicates that the frame reception was normally stopped by the inverted parity detection event. Relates to the TypeA RM 212-848 kbit/s modes. 12 RX_STOP_ON_PATTERN R 0h The high level indicates that the frame reception was normally stopped by EOF pattern detection event. Relates to the TypeB RM/CM, B prime RM/CM modes.
12	RX_STOP_ON_PATTERN	r/w	0*,1	The high level indicates that the frame reception was normally stopped by EOF pattern detection event. Relates to the TypeB RM/CM, B prime RM/CM modes.
11	RX_STOP_ON_ANTICOLL	r/w	0*,1	The high level indicates that the frame reception was normally stopped by collision detected on data bit position. Relates to the bit-oriented frame reception in TypeA RM 106 kbit/s mode during the anti-collision procedure.
10	RX_CRC_ERROR	r/w	0*,1	The high level indicates that the CRC error is detected in the received frame.
9	RX_LEN_ERROR	r/w	0*,1	The high level is set if the received frame is shorter than the length stated in the received frame LEN field OR if the LEN parameter in the received frame violates the configured [RX_FRAME_MINLEN:RX_FRAME_MAX LEN] limits. Can assert only in the mode where the LEN field is used in the frame format (FeliCa RM/CM, FWEC RM/CM).
8	RX_SIGPRO_ERROR	r/w	0*,1	The high level indicates that the communication error/errors were detected during the frame reception on physical layer(in the SigPro).
7	RX_PARITY_ERROR	r/w	0*,1	The high level indicates that the parity error was detected during the frame reception.
6	RX_STOPBIT_ERROR	r/w	0*,1	The high level indicates that the stop bit error ('0' level instead of '1' on the stop bit position) was detected during the frame reception.
5	RX_WRITE_ERROR	r/w	0*,1	The high level indicates that the error acknowledge status was received on the CLIF-system interface during the received frame transmission to the System RAM.
4	RX_BUFFER_OVFL_ERROR	r/w	0*,1	The high level indicates that the data payload length in the received frame exceeds the 28 bytes limit. Relates to the PollReq procedure in the FeliCa RM mode only.
3	RX_LATENCY_ERROR	r/w	0*,1	The high level indicates that the write request flow was corrupted due to traffic congestion on the system interface during the received frame transmission to the System RAM.
2	RX_DATA_INTEGRITY_ERROR	r/w	0*,1	The high level indicates that the data integrity corruption (parity/CRC/etc error) was detected in the received frame.

Table 65. RX_STATUS_ERROR register (address 0006h) bit description...continued

Bit	Symbol	Access	Value	Description
1	RX_PROTOCOL_ERROR	r/w	0*,1	The high level indicates that the protocol requirements violation (stop bit error, missing parity bit, not full byte received, etc) was detected in the received frame.
0	RX_CL_ERROR	r/w	0*,1	The high level indicates that some protocol/data integrity error/errors were detected during the frame reception

9.23.9 CLIF_STATUS (0007h)

Table 66. CLIF_STATUS register (address 0007h) bit description

Bit	Symbol	Access	Value	Description
31:30	RFU	r	0*,1	-
29	CRC_OK	r	0*,1	This bit indicates the status of the actual CRC calculation. If 1 the CRC is correct. meaning the CRC register has the value 0 or the residue value if inverted CRC is used. Note: This flag should only be evaluated at the end of a communication
28	RX_SC_DETECTED	r	0*,1	Status signal indicating that a subcarrier is detected.
27	RX_SOF_DETECTED	r	0*,1	Status signal indicating that a SOF has been detected.
26	TX_RF_STATUS	r	0*,1	If set to 1 this bit indicates that the drivers are turned on. meaning an RF-Field is created by the device itself.
25	RF_DET_STATUS	r	0*,1	If set to 1 this bit indicates that an external RF-Field is detected by the RF level detectors (after digital filtering)
24	ADC_Q_CLIPPING	r	0*,1	Indicates that the Q-Channel ADC has clipped (value 0 or 63), This bit is reset with Rx-reset (enabling of receiver).
23	ADC_I_CLIPPING	r	0*,1	Indicates that the I-Channel ADC has clipped (value 0 or 63), This bit is reset with Rx-reset (enabling of receiver).
22:12	RFU	r	0*,1	-
11	TX_NO_DATA_ERROR	r	0*,1	This error flag is set to 1. in case a transmission is started but no data is available (register NumBytesToSend == 0).

Table 66. CLIF_STATUS register (address 0007h) bit description...continued

Bit	Symbol	Access	Value	Description
10:8	RF_ACTIVE_ERROR_CAUSE	r	0*,1	This status flag indicates the cause of an NFC-Active error. Note: These bits are only valid when the RF_ACTIVE_ERROR_IRQ is raised and will be cleared as soon as the bit TX_RF_ENABLE is set to 1. 0* No Error. reset value 1 External field was detected on within TIDT timing 2 External field was detected on within TADT timing 3 No external field was detected within TADT timings 4 Peer did switch off RF Field without but no RX event was raised (no data received) 5 - 7 Reserved.
7:6	RFU	r	0*,1	-
5	RX_ENABLE	r	0*,1	This bit indicates if the RxDecoder is enabled. If 1 the RxDecoder was enabled and is now ready for data reception
4	TX_ACTIVE	r	0*,1	This bit indicates activity of the TxEncoder. If 1 a transmission is ongoing otherwise the TxEncoder is in idle state.
3	RX_ACTIVE	r	0*,1	This bit indicates activity of the RxDecoder. If 1 a data reception is ongoing. otherwise the RxDecoder is in idle state.
2:0	RF_EXCHANGE_STATE	r	0*,1	These registers hold the command bits 0* IDLE state 1 WaitTransmit state 2 Transmitting state 3 WaitReceive state 4 WaitForData state 5 Receiving state 6 LoopBack state 7 reserved

9.23.10 RF_EXCHANGE_CONTROL (0008h)

To meet the ISO14443A FDT with an accuracy of 1 carrier clock cycle, there is support implemented to synchronize the guard time pre-scaler to the modified Miller envelope pulses (end of pulse). For adjustment, there is a 7-bit wide configuration register - TX_BITPHASE - which allows to adjust the FDT in the range of 0 to 128 carrier clock cycles. As defined in the ISO14443 the adjustment is different, depending on the data bit value of the data stream. For correct bit grid calculation, the pre-scaler must be set to a value corresponding exactly to one etu - for 106 kbit/s this corresponds to 0x7F. Otherwise the FdT will be incorrect.

Table 67. RF_EXCHANGE_CONTROL register (address 0008h) bit description

Bit	Symbol	Access	Value	Description
31:16	RFU	r	0*,1	-
15:8	TX_BITPHASE	r/w	0*,1	Defines the number of 13.56 MHz cycles used for adjustment of TX_WAIT to meet the FDT. This is applicable for CardMode only.

Table 67. RF_EXCHANGE_CONTROL register (address 0008h) bit description...continued

Bit	Symbol	Access	Value	Description
7:3	RFU	r/w	0*,1	-
2	RX_MULTIPLE_ENABLE	r/w	0*,1	If this bit is set to 1. the receiver is reactivated after the end of a reception.
1:0	RFU	r/w	0*,1	-

9.23.11 TX_SYMBOL01_MOD (0009h)

Table 68. TX_SYMBOL01_MOD register (address 0009h) bit description

Bit	Symbol	Access	Value	Description
31:24	RFU	rw	0*,1	-
23:16	TX_S01_MODWIDTH	rw	0*,1	Specifies the length of a pulse for sending data of symbol 0/1. The length is given by the number of carrier clocks + 1.
15:9	RFU	rw	0*,1	-
8	TX_S01_MILLER_ENABLE	rw	0*,1	If set to 1. pulse modulation is applied according to modified miller coding.
7:5	TX_S01_INV_ENV	rw	0*,1	If set to 1. the output envelope is inverted.
4	TX_S01_ENV_TYPE	rw	0*,1	Specifies the type of envelope used for transmission of data packets. The selected envelope type is applied to the pseudo bit stream. 000b Direct output 001b Manchester code 010b Manchester code with subcarrier 011b BPSK 100b RZ (pulse of half bit length at beginning of second half of bit) 101b RZ (pulse of half bit length at beginning of bit) 110b Manchester tuple 111b RFU.
3	TX_S01_SC_FREQ	rw	0*,1	Specifies the frequency of the subcarrier. 0 424 kHz 1 848 kHz
2:0	TX_S01_BIT_FREQ	rw	0*,1	Specifies the frequency of the bit-stream. 000b -> 1.695 MHz. 001b -> Reserved. 010b -> 26 kHz. 011b -> 53 kHz. 100b -> 106 kHz. 101b -> 212 kHz. 110b -> 424 kHz. 111b -> 848 kHz.

9.23.12 TX_SYMBOL1_DEF (000Ah)

Table 69. TX_SYMBOL1_DEF register (address 000Ah) bit description

Bit	Symbol	Access	Value	Description
31:0	TX_SYMBOL1_DEF	RW	0*,1	Pattern definition for Symbol1

9.23.13 TX_SYMBOL0_DEF (000Bh)

Table 70. TX_SYMBOL0_DEF register (address 000Bh) bit description

Bit	Symbol	Access	Value	Description
31:0	TX_SYMBOL0_DEF	RW	0*,1	Pattern definition for Symbol0

9.23.14 TX_SYMBOL23_MOD (000Ch)

Table 71. TX_SYMBOL23_MOD register (address 000Ch) bit description

Bit	Symbol	Access	Value	Description
31:24	RFU	r	0*,1	-
23:16	TX_S23_MODWIDTH	r/w	0*,1	Specifies the length of a pulse for sending data of symbol 2/3. The length is given by the number of carrier clocks + 1.
15:9	RFU	r/w	0*,1	-
8	TX_S23_MILLER_ENABLE	r/w	0*,1	If set to 1 pulse modulation is applied according to modified miller coding
7	TX_S23_INV_ENV	r/w	0*,1	If set to 1 the output envelope is inverted.
6:4	TX_S23_ENV_TYPE	r/w	0*,1	Specifies the type of envelope used for transmission of data packets. The selected envelope type is applied to the pseudo bit stream. 000b Direct output 001b Manchester code 010b Manchester code with subcarrier 011b BPSK 100b RZ (pulse of half bit length at beginning of second half of bit) 101b RZ (pulse of half bit length at beginning of bit) 110b Manchester tupple 111b RFU
3	TX_S23_SC_FREQ	r/w	0*,1	Specifies the frequency of the subcarrier. 0 424 kHz 1 848 kHz
2:0	TX_S23_BIT_FREQ	r/w	0*,1	Specifies the frequency of the bit-stream. 000b -> 1.695 MHz. 001b -> Reserved. 010b -> 26 kHz. 011b -> 53 kHz. 100b -> 106 kHz. 101b -> 212 kHz. 110b -> 424 kHz. 111b -> 848 kHz.

9.23.15 TX_SYMBOL23_DEF (000Dh)

Table 72. TX_SYMBOL23_DEF register (address 000Dh) bit description

Bit	Symbol	Access	Value	Description
31:24	RFU	r	0*,1	-
23:16	TX_SYMBOL3_DEF	r/w	0*,1	Pattern definition for Symbol3
15:8	RFU	r/w	0*,1	-
7:0	TX_SYMBOL2_DEF	r/w	00000h* - FFFFFh	Pattern definition for Symbol2

9.23.16 TX_SYMBOL_CONFIG (000Eh)

Table 73. TX_SYMBOL_CONFIG register (address 000Eh) bit description

Bit	Symbol	Access	Value	Description
31	RFU		0*,1	-

Table 73. TX_SYMBOL_CONFIG register (address 000Eh) bit description...continued

Bit	Symbol	Access	Value	Description
30:27	TX_SYMBOL1_BURST_LEN	r/w	0000h* - FFFFh	Specifies the number of bits issued for symbol 1 burst. The 3 bits encode a range from 8 to 256 bit length: 0000b 8 bit 0001b 12 bit 0010b 16 bit 0011b 24 bit 0100b 32 bit 0101b 40 bit 0110b 48 bit 0111b 64 bit 1000b 80 bit 1001b 96 bit 1010b 112 bit 1011b 128 bit 1100b 160 bit 1101b 192 bit 1110b 224 bit 1111b 256 bit
26	TX_SYMBOL1_BURST_TYPE	r/w	0*,1	Specifies the type of the burst of Symbol1 (logical zero / logical one)
25	TX_SYMBOL1_BURST_ONLY	r/w	0*,1	If set to 1. Symbol1 consists only of a burst and no symbol pattern
24	TX_SYMBOL1_BURST_ENABLE	r/w	0*,1	If set to 1. the burst of Symbol0 of the length defined in bit field SYMBOL1_BURST_LEN is enabled
23	RFU	r	0*,1	-
22:19	TX_SYMBOL0_BURST_LEN	r/w	0*,1	Specifies the number of bits issued for symbol 0 burst. The 3 bits encode a range from 8 to 256 bit length: 0000b 8 bit 0001b 12 bit 0010b 16 bit 0011b 24 bit 0100b 32 bit 0101b 40 bit 0110b 48 bit 0111b 64 bit 1000b 80 bit 1001b 96 bit 1010b 112 bit 1011b 128 bit 1100b 160 bit 1101b 192 bit 1110b 224 bit 1111b 256 bit
18	TX_SYMBOL0_BURST_TYPE	r/w	0*,1	Specifies the type of the burst of Symbol0 (logical zero / logical one)
17	TX_SYMBOL0_BURST_ONLY	r/w	0*,1	If set to 1. Symbol0 consists only of a burst and no symbol pattern
16	TX_SYMBOL0_BURST_ENABLE	r/w	0*,1	If set to 1. the burst of Symbol0 of the length defined in bit field SYMBOL0_BURST_LEN is enabled
15:13	TX_SYMBOL3_LEN	r/w	0*,1	Specifies the number of valid bits of the symbol definition of Symbol3. The range is from 1 bit (value 0000) to 8 bit (value 111)
12:10	TX_SYMBOL2_LEN	r/w	0*,1	Specifies the number of valid bits of the symbol definition of Symbol2. The range is from 1 bit (value 0000) to 8 bit (value 111)
9:5	TX_SYMBOL1_LEN	r/w	0*,1	Specifies the number of valid bits of the symbol definition of Symbol1. The range is from 1 bit (value 0000) to 31 bits (value 11110)
4:0	TX_SYMBOL0_LEN	r/w	0*,1	Specifies the number of valid bits of the symbol definition of Symbol0. The range is from 1 bit (value 0000) to 31 bits (value 11110)

9.23.17 TX_FRAME_CONFIG (000Fh)

Table 74. TX_FRAME_CONFIG register (address 000Fh) bit description

Bit	Symbol	Access	Value	Description
31:19	RFU	r	0*,1	-

Table 74. TX_FRAME_CONFIG register (address 000Fh) bit description...continued

Bit	Symbol	Access	Value	Description
18:16	TX_DATA_CODE_TYPE	r/w	0*,1	Specifies the type of encoding of data to be used 000b No special code 001b 1 out of 4 code [ICODE SLI] 010b 1 out of 256 code [ICODE SLI] 011b Pulse interval encoding (PIE) [ICODE EPC-V2] 100b 2bit tuple code (intended only for test purpose) 101-111b Reserved
15:13	TX_STOPBIT_TYPE	r/w	0*,1	Enables the stop bit (logic 1) and extra guard time (logic 1). The value 0 disables transmission of stop-bits. 000b no stop-bit. no EGT 001b stop-bit. no EGT 010b stop-bit + 1 EGT 011b stop-bit + 2 EGT 100b stop-bit + 3 EGT 101b stop-bit + 4 EGT 110b stop-bit + 5 EGT 111b stop-bit + 6 EGT
12	TX_STARTBIT_ENABLE	r/w	0*,1	If set to 1. a start-bit (logic 0) will be sent
11	TX_MSB_FIRST	r/w	0*,1	If set to 1. data bytes are interpreted MSB first for data transmission
10	TX_PARITY_LAST_INV_ENABLE	r/w	0*,1	If set to 1. the parity bit of last sent data byte is inverted
9	TX_PARITY_TYPE	r/w	0*,1	Defines the type of the parity bit 0 Even Parity is calculated 1 Odd parity is calculated
8	TX_PARITY_ENABLE	r/w	0*,1	If set to 1. a parity bit is calculated and appended to each byte transmitted. If the Transmission Of Data Is Enabled and TX_NUM_BYTES_2_SEND is zero. then a NO_DATA_ERROR occurs.
7:5	RFU	r	0*,1	-
4	TX_DATA_ENABLE	r/w	0*,1	If set to 1. transmission of data is enabled otherwise only symbols are transmitted.
3:2	TX_STOP_SYMBOL	r/w	0*,1	Defines which pattern symbol is sent as frame stop-symbol 00b No symbol is sent 01b Symbol1 is sent 10b Symbol2 is sent 11b Symbol3 is sent
1:0	TX_START_SYMBOL	r/w	0*,1	Defines which symbol pattern is sent as frame start-symbol 00b No symbol pattern is sent 01b Symbol0 is sent 10b Symbol1 is sent 11b Symbol2 is sent

9.23.18 TX_DATA_MOD (0010h)

Table 75. TX_DATA_MOD register (address 0010h) bit description

Bit	Symbol	Access	Value	Description
31:25	RFU	r	0*,1	-
24	TX_ICODE_DATA_MODWIDTH_ENABLE	r/w	0*,1	Enables modulation width of icode data. Width of modulation is defined by the TX_DATA_MODWIDTH field. When 1, we should have TX_DATA_ENV_TYPE=0 and TX_DATA_INV_ENV=0
23:16	TX_DATA_MODWIDTH	r/w	0*,1	Specifies the length of a pulse for sending data with miller pulse modulation enabled. The length is given by the number of carrier clocks + 1.
15:9	RFU	r	0*,1	-

Table 75. TX_DATA_MOD register (address 0010h) bit description...continued

Bit	Symbol	Access	Value	Description
8	TX_DATA_MILLER_ENABLE	r/w	0*,1	If set to 1 pulse modulation is applied according to modified miller coding
7	TX_DATA_INV_ENV	r/w	0*,1	If set to 1 the output envelope is inverted
6:4	TX_DATA_ENV_TYPE	r/w	0*,1	Specifies the type of envelope used for transmission of data packets. The selected envelope type is applied to the pseudo bit stream. 000b Direct output 001b Manchester code 010b Manchester code with subcarrier 011b BPSK 100b RZ (pulse of half bit length at beginning of second half of bit) 101b RZ (pulse of half bit length at beginning of bit) 110b Manchester tuple coding 111b RFU
3	TX_DATA_SC_FREQ	r/w	0*,1	Specifies the frequency of the subcarrier. 0 424 kHz 1 848 kHz
2:0	TX_DATA_BIT_FREQ	r/w	0*,1	Specifies the frequency of the bit-stream. 000b -> 1.695 MHz. 001b -> Reserved. 010b -> 26 kHz. 011b -> 53 kHz. 100b -> 106 kHz. 101b -> 212 kHz. 110b -> 424 kHz. 111b -> 848 kHz.

9.23.19 TX_WAIT (0011h)

To guarantee correct protocol timing a guard period timer is implemented for the RF_EXCHANGE command in reception and transmission mode.

These guard times are not available for Transmit or Receive command.

The guard time TX_WAIT is started after the end of a reception no matter if the frame is correct or erroneous.

It is not started in case the reception is restarted because of an EMD-event or in case the RX_MULTIPLE_ENABLE bit is set to 1 the TX_WAIT.

In case the register flag TX_WAIT_RFON_ENABLE is set to 1 the guard time timer is started when the devices own RF-Field was switched on.

It is possible to disable the guard time tx_wait by setting the register TX_WAIT_VALUE to 00h.

TX_WAIT can be used for 2 different purposes:

1. It can be used to prevent start of transmission before a certain period has expired - even if FW already finished data processing and set the START_SEND bit. This behavior is mainly intended for reader mode to guaranteed PICC to PCD frame delay time (FDT).
2. TX_WAIT time can be used to start the transmission at an exactly defined time.

Table 76. TX_CLIF_WAIT register (address 0011h) bit description

Bit	Symbol	Access	Value	Description
31:28	RFU	r	0*,1	-
27:8	TX_WAIT_VALUE	r/w	0*,1	Defines the tx_wait timer reload value. Note: If set to 00000h the tx_wait timer guard time is disabled Note: This bit is set by HW a protocol is detected in automatic mode detection

Table 76. TX_CLIF_WAIT register (address 0011h) bit description...continued

Bit	Symbol	Access	Value	Description
0	TX_WAIT_PRESCALER	r/w	0*,1	Defines the prescaler reload value for the tx_wait timer. Note: This bit is set by HW a protocol is detected in automatic mode detection

9.23.20 TX_CRC_CONFIG (0012h)

Table 77. TX_CRC_CONFIG (address 0012h) bit description

Bit	Symbol	Access	Value	Description
31:16	TX_CRC_PRESET_VALUE	r/w	0*-FFFFh	Arbitrary preset value for the TX-Encoder CRC calculation.
15:7	RFU	r/w	0	Reserved
6	TX_CRC_BYTE2_ENABLE	r/w	0*,1	If set; the CRC is calculated from the second byte onwards (intended for HID). This option is used in the TX-Encoder.
5:3	TX_CRC_PRESET_SEL	r/w	000-101b	Preset values of the CRC register for the TX-Encoder. For a CRC calculation using 5 bits, only the LSByte is used.
			000b*	0000h, reset value
			001b	6363h
			010b	A671h
			011b	FFFFh
			100b	0012h
			101b	E012h
			110b	RFU
2	TX_CRC_TYPE	r/w	0*,1	Controls the type of CRC calculation for the TX-Encoder
			0*	16-bit CRC calculation, reset value
			1	5-bit CRC calculation
1	TX_CRC_INV	r/w	0*,1	Controls the sending of an inverted CRC value by the TX-Encoder
			0*	Not inverted CRC checksum, reset value
			1	Inverted CRC checksum
0	TX_CRC_ENABLE	r/w	0*, 1	If set to one, the TX-Encoder computes and transmits a CRC.

9.23.21 SS_TX_CONFIG (00015h)

Table 78. SS_TX_CONFIG register (address 0015h) bit description

Bit	Symbol	Access	Value	Description
31:14	RFU	r	0*,1	-

Table 78. SS_TX_CONFIG register (address 0015h) bit description...continued

Bit	Symbol	Access	Value	Description
13	TX2_USE_TX1_CONF	r/w	0*,1	When 1, the tx1 configuration is used also for tx2: all SS_TX2_* registers are discarded and configurations from corresponding SS_TX1_* register is used.
12:6	RFU	r/w	0*,1	-
5:3	TX2_CLK_MODE_DEFAULT	r/w	0*,1	TX2 clk mode without field (RM and CM)
2:0	TX1_CLK_MODE_DEFAULT	r/w	0*,1	TX1 clk mode without field (RM and CM)

9.23.22 SS_TX1_RMCFG (00016h)

Table 79. SS_TX1_RMCFG register (address 0016h) bit description

Bit	Symbol	Access	Value	Description
31:25	RFU	r	0*,1	-
24:22	TX1_CLK_MODE_TRANS_RM	r/w	0*,1	TX1 clock mode in RM during transition
21:19	TX1_CLK_MODE_MOD_RM	r/w	0*,1	TX1 clock mode of modulated wave in RM 000: TX1=High-Z 001: TX1=VSS_PA 010 - 110: RFU 111: TX1 clocked normal operation
18:16	TX1_CLK_MODE_CW_RM	r/w	0*,1	TX1 clock mode of modulated wave in RM 000: TX1=High-Z 001: TX1=VSS_PA 010 - 110: RFU 111: TX1 clocked normal operation
15:8	TX1_AMP_MOD_RM	r/w	0*,1	TX1 amplitude of modulated wave in RM (0x00 = 0% modulation, 0xFF: 100% modulation)
7:0	TX1_AMP_CW_RM	r/w	0*,1	TX1 amplitude of unmodulated wave in RM (0x00 = 0% signal, 0xFF: 100% signal)

9.23.23 SS_TX2_RMCFG (00017h)

These settings for TX_2 are only applied, if the bit 13 in TX_CONFIG (TX2_USE_TX1_CONF is set to 0.

Table 80. SS_TX2_RMCFG register (address 0017h) bit description

Bit	Symbol	Access	Value	Description
31:25	RFU	r	0*,1	-
24:22	TX2_CLK_MODE_TRANS_RM	r/w	0*,1	TX2 clock mode in RM during transition
21:19	TX2_CLK_MODE_MOD_RM	r/w	0*,1	TX2 clock mode of modulated wave in RM 000: TX2=High-Z 001: TX2=VSS_PA 010 - 110: RFU 111: TX2 clocked normal operation

Table 80. SS_TX2_RMCFG register (address 0017h) bit description...continued

Bit	Symbol	Access	Value	Description
18:16	TX2_CLK_MODE_CW_RM	r/w	0*,1	TX2 clock mode of modulated wave in RM 000: TX2=High-Z 001: TX2=VSS_PA 010 - 110: RFU 111: TX2 clocked normal operation
15:8	TX2_AMP_MOD_RM	r/w	0*,1	TX2 amplitude of modulated wave in RM (0x00 = 0% modulation, 0xFF: 100% modulation)
7:0	TX2_AMP_CW_RM	r/w	0*,1	TX2 amplitude of unmodulated wave in RM (0x00 = 0% signal, 0xFF: 100% signal)

9.23.24 SS_TX_TRANS_CFG (00019h)

Table 81. SS_TX_TRANS_CFG register (address 0019h) bit description

Bit	Symbol	Access	Value	Description
31:12	RFU			-
11	TX2_SS_TRANS_RATE			TX2 shaping edge rate: 0: 1/fc, 1: 2/fc. 1/fc should be selected for CM.
10	TX1_SS_TRANS_RATE			TX1 shaping edge rate: 0: 1/fc, 1: 2/fc. 1/fc should be selected for CM
9:5	TX2_SS_TRANS_LENGTH			TX2 shaping edge length: from 0 (disable) to 16. for CM, only 0 or 4 values are valid
4:0	TX1_SS_TRANS_LENGTH			TX1 shaping edge length: from 0 (disable) to 16. for CM, only 0 or 4 values are valid

9.23.25 SIGPRO_RM_PATTERN (0020h)

Table 82. SIGPRO_RM_PATTERN register (address 0020h) bit description

Bit	Symbol	Access	Value	Description
31:16	RM_SYNC_PATTERN	r/w	0*,1	Sync pattern for FeliCa. LSB transmitted last
15	RM_SYNC_PATTERN_EXT4	r/w	0*,1	Extend FeliCa sync pattern with 16 leading 0s
14	RM_SYNC_PATTERN_EXT2	r/w	0*,1	Extend FeliCa sync pattern with 8 leading 0s
13	RM_RECEIVE_TILL_END	r/w	0*,1	Do not stop the reception before RxDecoder sends a stop command.
12	RFU	r	0*,1	-
11:0	RM_SOF_PATTERN	r/w	0*,1	SOF pattern for Type B. LSB transmitted last or Start Byte pattern for NFC passive.

9.23.26 SIGPRO_RM_TECH (0022h)

Table 83. SIGPRO_RM_TECH register (address 0022h) bit description

Bit	Symbol	Access	Value	Description
31:17	RFU	rw	0	-

Table 83. SIGPRO_RM_Tech register (address 0022h) bit description...continued

Bit	Symbol	Access	Value	Description
16:15	RM_MF_GAIN	rw	0	Defines the gain of the Matched-Filters 00: Minimum Gain, 11: Maximum Gain
14:0	RFU	rw	0	-

9.23.27 RX_FRAME_LENGTH (0026h)

Table 84. RX_FRAME_LENGTH register (address 0026h) bit description

Bit	Symbol	Access	Value	Description
31	RFU	r	0*,1	-
30:16	RX_FRAME_MAXLEN	r/w	0*,1	Maximal number of received [DATA + CRC] bits in the frame. The violation of the maximum length limit can be also configured as an Error/EMD condition. If the max length violation is configured as error - the frame reception is stopped in case of maximum length limit exceeding. Otherwise the reception is continued.0x0000 - 1 bit...0x7FFF - 32 kbit
15	RFU	r	0*,1	-
14:0	RX_FRAME_MINLEN	r/w	0*,1	Minimal number of received [DATA + CRC] bits in the frame. The violation of the minimum length limit can be also configured as an Error/EMD condition. The parameter also defines the number of received[DATA + CRC] bits before which any of the EOF patterns or INVPAR stop condition events are ignored.0x0000 - 1 bit...0x7FFF - 32 kbit

9.23.28 RX_ERROR_CONFIG (0027h)

Table 85. RX_ERROR_CONFIG register (address 0027h) bit description

Bit	Symbol	Access	Value	Description
31:0		rw		xxx NFC FORUM-compliant error handling yyy EMVCO-compliant error handling zzz compliant error handling

9.23.29 RX_CTRL_STATUS (0028h)

Table 86. RX_CTRL_STATUS register (address 0028h) bit description

Bit	Symbol	Access	Value	Description
31:9	RFU	r	dyn	-
8:3	RXCTRL_HF_ATT_VAL	r	dyn	HF attenuator value
2:0	RFU	r	dyn	-

9.23.30 SIGPRO_IIR_CONFIG0 (0002Ah)

Table 87. SIGPRO_IIR_CONFIG0 register (address 002Ah) bit description

Bit	Symbol	Access	Value	Description
31:1	RFU			-
0	IIR_ENABLE			Enable the IIR filter

9.23.31 DGRM_RSSI (0030h)

This register is updated dynamically by the firmware if the DPC is enabled.

Table 88. DGRM_RSSI register (address 0030h) bit description

Bit	Symbol	Access	Value	Description
31:30	RFU			-
29	DGRM_SIGNAL_DETECT_TH_OVR	r/w	0*,1	Enables the override of signal detect threshold. Override value is set based on DGRM_SIGNAL_DETECT_TH_OVR_VAL.
28:23	RFU	r/w	0*,1	-
22:17	DGRM_RSSI_HYST	r/w	0*,1	Hysteresis value for RSSI target
16:7	DGRM_RSSI_TARGET	r/w	0*,1	RSSI target value
6:0	DGRM_SIGNAL_DETECT_TH_OVR_VAL	r/w	0*,1	Defines the override value for signal detect threshold when DGRM_SIGNAL_DETECT_TH_OVR is set. These bits are modified dynamically by the ARC algorithm based on the DPC voltage. Only if the ARC is disabled, the value written during LOAD_RF_CONFIGURATION(0x0D) is retained throughout the RF Field session.

9.23.32 RX_CRC_CONFIG (0031h)

Table 89. RX_CRC_CONFIG register (address 0031h) bit description

Bit	Symbol	Access	Value	Description
31:16	RX_CRC_PRESET_VALUE	r	0*,1	Arbitrary preset value for the Rx-Decoder CRC calculation.
15:8	RFU	r/w	0*,1	-
7	RX_FORCE_CRC_WRITE	r/w	0*,1	If set, the Rx-Decoder will send to the RAM the CRC bits as well.
6	RX_CRC_ALLOW_BITS	r/w	0*,1	If activated the frame with length =< CRC_length will be always sent to the System RAM as is, without CRC bits removal.

Table 89. RX_CRC_CONFIG register (address 0031h) bit description...continued

Bit	Symbol	Access	Value	Description
5:3	RX_CRC_PRESET_SEL	r/w	0*,1	Preset value of the CRC register for the Rx-Decoder. For a CRC calculation using 5bits only the LSByte is used. 000b* 0000h reset value. Note that this configuration is set by the Mode detector for FeliCa. 001b 6363h Note that this configuration is set by the Mode detector for ISO14443 type A. 010b A671h 011b FFFFh Note that this configuration is set by the Mode detector for ISO14443 type B. 100b 0012h 101b E012h 110b RFU 111b Use arbitrary preset value RX_CRC_PRESET_VALUE
2	RX_CRC_TYPE	r/w	0*,1	Controls the type of CRC calculation for the Rx-Decoder 0* 16bit CRC calc
1	RX_CRC_INV	r/w	0*,1	Controls the comparison of the CRC checksum for the Rx-Decoder 0*: Not inverted CRC value: 0000h reset value. Note that this bit is cleared by the Mode detector for ISO14443 type A and FeliCa. 1: Inverted CRC value: F0B8h Note that this bit is set by the Mode detector for ISO14443 type B
0	RX_CRC_ENABLE			If set. the Rx-Decoder will check the CRC for correctness. Note that this bit is set by the Mode Detector when ISO14443 type B. or FeliCa (212 kBd or 424 kBd) is detected.

9.23.33 RX_WAIT (0032h)

To guarantee correct protocol timing a guard period timer is implemented for the RF_EXCHANGE command in reception and transmission mode.

These guard times are not available for Transmit or Receive command.

The guard time RX_WAIT is started after the end of a transmission. The guard time RX_WAIT can be disabled by setting the register RX_WAIT_VALUE to 00h meaning the receiver is immediately enabled.

Table 90. RX_WAIT register (address 0032h) bit description

Bit	Symbol	Access	Value	Description
31:28	RFU	r	0*,1	-
27:8	RX_WAIT_VALUE	r/w	0*,1	Defines the rx_wait timer reload value. Note: If set to 00000h the rx_wait guard time is disabled
7:0	RX_WAIT_PRESCALER	r/w	0*,1	Defines the prescaler reload value for the rx_wait timer.

9.23.34 RXM_CTRL (0035h)

Table 91. RXM_CTRL register (address 0035h) bit description

Bit	Symbol	Access	Value	Description
31:3	RFU			-
2	RXM_FRQ_CHECK_PCRM_ENABLE	r/w		enable frequency check from PCRM
1	RXM_FRQ_CHECK_CORDIC_ENABLE	r/w		enable precise frequency check from cordic phase (+/- 1.7 MHz multiples)
0	RXM_ENABLE	r/w		enable the all RxMeasure module

9.23.35 SS_TX1_CMCFG (0003Bh)

Table 92. SS_TX1_CMCFG register (address 003Bh) bit description

Bit	Symbol	Access	Reset Value	Description
31:22	RFU	rw	0	-
21:19	TX1_CLK_MODE_MOD_CM	rw	0	TX1 clock mode of modulated wave in CM
18:16	TX1_CLK_MODE_CW_CM	rw	0	TX1 clock mode of unmodulated wave in CM
15:8	TX1_AMP_MOD_CM	rw	0	TX1 clock mode of modulated wave in CM
7:0	TX1_AMP_CW_CM	rw	0xFF	TX1 clock mode of unmodulated wave in CM

9.23.36 SS_TX2_CMCFG (0003Ch)

Table 93. SS_TX2_CMCFG register (address 003Ch) bit description

Bit	Symbol	Access	Reset Value	Description
31:22	RFU	rw	0	-
21:19	TX2_CLK_MODE_MOD_CM	rw	0	TX2 clock mode of modulated wave in CM
18:16	TX2_CLK_MODE_CW_CM	rw	0	TX2 clock mode of unmodulated wave in CM
15:8	TX2_AMP_MOD_CM	rw	0	TX2 clock mode of modulated wave in CM
7:0	TX2_AMP_CW_CM	rw	0xFF	TX2 clock mode of unmodulated wave in CM

9.23.37 TIMER0_CONFIG (003Dh)

Table 94. TIMER0_CONFIG register (address 003Dh) bit description

Bit	Symbol	Access	Value	Description
31:9	RFU	r	0*,1	-
8	T0_START_NOW	r/w	0*,1	T0_START_EVENT: If set. the timer T0 is started immediately
7	RFU	r	0*,1	-
6	T0_ONE_SHOT_MODE	r/w	0*,1	When set to 1, the counter value does not reload again until the counter value has reached zero

Table 94. TIMER0_CONFIG register (address 003Dh) bit description ...continued

Bit	Symbol	Access	Value	Description
5:3	T0_PRESCALE_SEL	r/w	0*,1	Controls input frequency/period of the timer T0 when the prescaler is activated in T0_MODE_SEL. 000b - 6.78 MHz counter 001b - 3.39 MHz counter 010b - 1.70 MHz counter 011b - 848 kHz counter 100b - 424 kHz counter 101b - 212 kHz counter 110b - 106 kHz counter 111b - 53 kHz counter
2	T0_MODE_SEL	r/w	0*,1	Configuration of the timer T0 clock. 0b - Prescaler is disabled: the timer frequency matches CLIF clock frequency (13.56 MHz). 1b - Prescaler is enabled: the timer operates on the prescaler signal frequency (chosen by T0_PRESCALE_SEL).
1	T0_RELOAD_ENABLE	r/w	0*,1	If set to 0b - the timer T0 will stop on expiration. 0* After expiration the timer T0 will stop counting. i.e. remain zero. reset value. 1b - After expiration the timer T0 will reload its preset value and continue counting down.
0	T0_ENABLE	r/w	0*,1	Enables the timer T0

9.23.38 TIMER0_RELOAD (003Eh)

Table 95. TIMER0_RELOAD register (address 003Eh) bit description

Bit	Symbol	Access	Value	Description
31:20	RFU	r	0*,1	-
19:0	T0_RELOAD_VALUE	r/w	0*,1	Reload value of the timer T0.

9.23.39 TIMER1_CONFIG (003Fh)

Timer 1 is typically used for the FDT configuration. Configuration can be done from the host but the associated IRQ is handled by the firmware of the PN5190B1.

Table 96. TIMER1_CONFIG register (address 003Fh) bit description

Bit	Symbol	Access	Value	Description
31	RFU	r	0*,1	-
30	T1_STOP_ON_RX_STARTED	r/w	0*,1	T1_STOP_EVENT: If set. the timer T1 is stopped when a data reception begins (1st bit is received).
29	T1_STOP_ON_TX_STARTED	r/w	0*,1	T1_STOP_EVENT: If set. the timer T1 is stopped when a data transmission begins.
28	T1_STOP_ON_RF_ON_EXT	r/w	0*,1	T1_STOP_EVENT: If set. the timer T1 is stopped when the external RF field is detected.

Table 96. TIMER1_CONFIG register (address 003Fh) bit description ...continued

Bit	Symbol	Access	Value	Description
27	T1_STOP_ON_RF_OFF_EXT	r/w	0*,1	T1_STOP_EVENT: If set. the timer T1 is stopped when the external RF field vanishes.
26	T1_STOP_ON_RF_ON_INT	r/w	0*,1	T1_STOP_EVENT: If set. the timer T1 is stopped when the internal RF field is turned on.
25	T1_STOP_ON_RF_OFF_INT	r/w	0*,1	T1_STOP_EVENT: If set. the timer T1 is stopped when the internal RF field is turned off.
24	T1_STOP_ON_RX_ENDED	r/w	0*,1	T1_STOP_EVENT: If set the timer T1 is stopped when an activity on RX is detected.
23:18	RFU	r	0*,1	-
17	T1_START_ON_RX_STARTED	r/w	0*,1	T1_START_EVENT: If set. the timer T1 is started when a data reception begins (1st bit is received).
16	T1_START_ON_RX_ENDED	r/w	0*,1	T1_START_EVENT: If set. the timer T1 is started when a data reception ends.
15	T1_START_ON_TX_STARTED	r/w	0*,1	T1_START_EVENT: If set. the timer T1 is started when a data transmission begins.
14	T1_START_ON_TX_ENDED	r/w	0*,1	T1_START_EVENT: If set. the timer T1 is started when a data transmission ends.
13	T1_START_ON_RF_ON_EXT	r/w	0*,1	T1_START_EVENT: If set. the timer T1 is started when the external RF field is detected.
12	T1_START_ON_RF_OFF_EXT	r/w	0*,1	T1_START_EVENT: If set. the timer T1 is started when the external RF field is not detected anymore.
11	T1_START_ON_RF_ON_INT	r/w	0*,1	T1_START_EVENT: If set. the timer T1 is started when an internal RF field is turned on.
10	T1_START_ON_RF_OFF_INT	r/w	0*,1	T1_START_EVENT: If set. the timer T1 is started when an internal RF field is turned off.
9	T1_START_ON_TX_FRAMESTEP	r/w	0*,1	T1_START_EVENT: If set. the timer T1 is started when an activity on Frame step is detected.
8	T1_START_NOW	r/w	0*,1	T1_START_EVENT: If set. the timer T1 is started immediately.
7	RFU	r	0*,1	-
6	T1_ONE_SHOT_MODE	r/w	0*,1	When set to 1, the counter value does not reload again until the counter value has reached zero
5:3	T1_PRESCALE_SEL	r/w	0*,1	Controls input frequency/period of the timer T0 when the prescaler is activated in T1_MODE_SEL. 000b - 6.78 MHz counter 001b - 3.39 MHz counter 010b - 1.70 MHz counter 011b - 848 kHz counter 100b - 424 kHz counter 101b - 212 kHz counter 110b - 106 kHz counter 111b - 53 kHz counter

Table 96. TIMER1_CONFIG register (address 003Fh) bit description ...continued

Bit	Symbol	Access	Value	Description
2	T1_MODE_SEL	r/w	0*,1	If set, the timer T1 is started the prescaler for the timer T1 is enabled. 0* Prescaler is disabled: the timer frequency matches CLIF clock frequency (13.56 MHz). 1 Prescaler is enabled: the timer operates on the prescaler signal frequency (chosen by T1_PRESCALE_SEL).
1	T1_RELOAD_ENABLE	r/w	0*,1	If set to 0, the timer T1 will stop on expiration. 0* After expiration the timer T1 will stop counting, i.e. remain zero, reset value. 1 After expiration the timer T1 will reload its preset value and continue counting down.
0	T1_ENABLE	r/w	0*,1	Enables the timer T1

9.23.40 TIMER1_RELOAD (0040h)

Table 97. TIMER1_RELOAD register (address 0040h) bit description

Bit	Symbol	Access	Value	Description
31:20	RFU	r	0*,1	-
19:0	T1_RELOAD_VALUE	r/w	0*,1	Reload value of the timer T1.

9.23.41 EMD_1_CFG (0047h)

This register allows to configure the ISO14443 and NFC-Forum EMD handling.

This register shall not be modified in case EMVCO or FeliCa EMD is activated.

Table 98. EMD_1_CFG register (address 0047h) bit description

Bit	Symbol	Access	Value	Value for ISO/IEC14443 EMD handling	Value for NFC Forum EMD handling	Description
31:0	EMD_1_Configuration	r/w		0000 FF03h	0000 FF04h	0000 FF03h EMD ISO 0000 FF04h EMD NFC Forum

9.23.42 EMD_0_CONFIG (0048h)

This register allows to configure the ISO14443 and NFC-Forum EMD handling.

This register shall not be modified in case EMVCO or FeliCa EMD is activated.

Table 99. EMD_0_CONFIG register (address 0048h) bit description

Bit	Symbol	Access	Value	Value for ISO/IEC14443 EMD handling	Value for NFC Forum EMD handling	Description
31:0	EMD_0_Configuration			176003 FFh	1F600 3FFh	Default value for ISO14443 and NFC Forum

9.23.43 LPCD_CALIBRATE_CTRL (00050h)

This register is used for LPCD semi autonomous mode. Writing to this register triggers the LPCD calibration with the RSSI_HYSTERESIS and RSSI_TARGET values as given in bits 23:16 and 15:0. After calibration is completed, calibration status is available in LPCD_CALIBRATE_STATUS. If the calibration is successful, the I/Q channel values can be read from register IQ_CHANNEL_VALS (51h).

Table 100. LPCD_CALIBRATE_CTRL register (address 0050h) bit description

Bit	Symbol	Access	Value	Description
31:24	RFU	r	0*,1	-
23:16	RSSI_HYSTERESIS	r/w	0*,1	Value to be set in DGRM_RSSI_HYST used for calibration
15:0	RSSI_TARGET	r/w	0*,1	Value to be set in DGRM_RSSI_TARGET used for calibration

9.23.44 IQ_CHANNEL_VALS (00051h)

Table 101. IQ_CHANNEL_VALS register (address 0051h) bit description

Bit	Symbol	Access	Value	Description
31:16	Q_CHANNEL_VAL	r	-	Q Channel value
15:0	I_CHANNEL_VAL	r	-	I Channel value

9.23.45 PAD_CONFIG (0052h)

Table 102. PAD_CONFIG register (address 0052h) bit description

Bit	Symbol	Access	Value	Description
31:7	RFU	RW		-
6	AUX3_OUTPUT_VAL	RW		Output value for AUX3 0: Low 1: High
5	AUX2_OUTPUT_VAL	RW		Output value for AUX2 0: Low 1: High
4	AUX1_OUTPUT_VAL	RW		Output value for AUX1 0: Low 1: High

Table 102. PAD_CONFIG register (address 0052h) bit description...continued

Bit	Symbol	Access	Value	Description
3	GPIO3_OUTPUT_VAL	RW		Output value for GPIO3 0: Low 1: High
2	GPIO2_OUTPUT_VAL	RW		Output value for GPIO2 0: Low 1: High
1	GPIO1_OUTPUT_VAL	RW		Output value for GPIO1 0: Low 1: High
0	GPIO0_OUTPUT_VAL	RW		Output value for GPIO0 0: Low 1: High

On PN5190B1 only output functionality is available on GPIO's.

9.23.46 CALIBRATE_STATUS (00053h)

Table 103. CALIBRATE_STATUS register (address 0053h) bit description

Bit	Symbol	Access	Value	Description
31	LPCD_CALIBRATION_STATUS	r	-	Calibration Status 0 - Calibration Not Done, 1- Calibration Done
30:1	RFU	r	-	-
0	TXNOV_CALIBRATION_STATUS			Calibration Status 0 - Calibration Not Done, 1- Calibration Done

9.23.47 TXLDO_VDDPA_CONFIG (00054h)

If DPC is disabled, the VDDPA supply voltage can be set with this register. These register settings are overruled by the DPC.

This register does allow to read the actual VDDPA supply voltage independent from having the DPC enabled/disabled, this allows to read-out the actual transmitter supply voltage.

Table 104. TXLDO_VDDPA_CONFIG register (address 0054h) bit description

Bit	Symbol	Access	Value	Description
31:8	RFU	rw		-

Table 104. TXLDO_VDDPA_CONFIG register (address 0054h) bit description...continued

Bit	Symbol	Access	Value	Description
7:0	VDDPA_CONFIG	rw		VDDPALDO output voltage VDDPA_1V50 /* 0x00 */ VDDPA_1V60, /* 0x01 */ VDDPA_1V70, /* 0x02 */ VDDPA_1V80, /* 0x03 */ VDDPA_1V90, /* 0x04 */ VDDPA_2V00, /* 0x05 */ VDDPA_2V10, /* 0x06 */ VDDPA_2V20, /* 0x07 */ VDDPA_2V30, /* 0x08 */ VDDPA_2V40, /* 0x09 */ VDDPA_2V50, /* 0x0A */ VDDPA_2V60, /* 0x0B */ VDDPA_2V70, /* 0x0C */ VDDPA_2V80, /* 0x0D */ VDDPA_2V90, /* 0x0E */ VDDPA_3V00, /* 0x0F */ VDDPA_3V10, /* 0x10 */ VDDPA_3V20, /* 0x11 */ VDDPA_3V30, /* 0x12 */ VDDPA_3V40, /* 0x13 */ VDDPA_3V50, /* 0x14 */ VDDPA_3V60, /* 0x15 */ VDDPA_3V70, /* 0x16 */ VDDPA_3V80, /* 0x17 */ VDDPA_3V90, /* 0x18 */ VDDPA_4V00, /* 0x19 */ VDDPA_4V10, /* 0x1A */ VDDPA_4V20, /* 0x1B */ VDDPA_4V30, /* 0x1C */ VDDPA_4V40, /* 0x1D */ VDDPA_4V50, /* 0x1E */ VDDPA_4V60, /* 0x1F */ VDDPA_4V70, /* 0x20 */ VDDPA_4V80, /* 0x21 */ VDDPA_4V90, /* 0x22 */ VDDPA_5V00, /* 0x23 */ VDDPA_5V10, /* 0x24 */ VDDPA_5V20, /* 0x25 */ VDDPA_5V30, /* 0x26 */ VDDPA_5V40, /* 0x27 */ VDDPA_5V50, /* 0x28 */ VDDPA_5V60, /* 0x29 */ VDDPA_5V70, /* 0x2A */

9.23.48 GENERAL_ERROR_STATUS (0055h)

Table 105. GENERAL_ERROR_STATUS register (address 0055h) bit description

Bit	Symbol	Access	Value	Description
31:3	RFU	r	0*,1	-
2	TXLDO_ERROR	r	0*,1	TXLDO does not start
1	CLOCK_ERROR	r	0*,1	XTAL or PLL does not start
0	GPADC_ERROR	r	0*,1	GPADC initialization fail

9.23.49 TXLDO_VOUT_CURR (0056h)

Table 106. TXLDO_VOUT_CURR register (address 0056h) bit description

Bit	Symbol	Access	Value	Description
31:24	RFU	r		-
23:8	TXLDO_CURRENT	r		Indicates the TXLDO Current, measured value is indicated in mA (1 bit = 1 mA)

Table 106. TXLDO_VOUT_CURR register (address 0056h) bit description...continued

Bit	Symbol	Access	Value	Description
7:0	VDDPA_VOUT	r		VDDPA output voltage VDDPA_1V50 /* 0x00 */ VDDPA_1V60, /* 0x01 */ VDDPA_1V70, /* 0x02 */ VDDPA_1V80, /* 0x03 */ VDDPA_1V90, /* 0x04 */ VDDPA_2V00, /* 0x05 */ VDDPA_2V10, /* 0x06 */ VDDPA_2V20, /* 0x07 */ VDDPA_2V30, /* 0x08 */ VDDPA_2V40, /* 0x09 */ VDDPA_2V50, /* 0x0A */ VDDPA_2V60, /* 0x0B */ VDDPA_2V70, /* 0x0C */ VDDPA_2V80, /* 0x0D */ VDDPA_2V90, /* 0x0E */ VDDPA_3V00, /* 0x0F */ VDDPA_3V10, /* 0x10 */ VDDPA_3V20, /* 0x11 */ VDDPA_3V30, /* 0x12 */ VDDPA_3V40, /* 0x13 */ VDDPA_3V50, /* 0x14 */ VDDPA_3V60, /* 0x15 */ VDDPA_3V70, /* 0x16 */ VDDPA_3V80, /* 0x17 */ VDDPA_3V90, /* 0x18 */ VDDPA_4V00, /* 0x19 */ VDDPA_4V10, /* 0x1A */ VDDPA_4V20, /* 0x1B */ VDDPA_4V30, /* 0x1C */ VDDPA_4V40, /* 0x1D */ VDDPA_4V50, /* 0x1E */ VDDPA_4V60, /* 0x1F */ VDDPA_4V70, /* 0x20 */ VDDPA_4V80, /* 0x21 */ VDDPA_4V90, /* 0x22 */ VDDPA_5V00, /* 0x23 */ VDDPA_5V10, /* 0x24 */ VDDPA_5V20, /* 0x25 */ VDDPA_5V30, /* 0x26 */ VDDPA_5V40, /* 0x27 */ VDDPA_5V50, /* 0x28 */ VDDPA_5V60, /* 0x29 */ VDDPA_5V70, /* 0x2A */

9.23.50 CLIF_DAC (00057h)

This register allows to configure the output voltage of VTUNE1, VTUNE2.

Table 107. CLIF_DAC register (address 0057h) bit description

Bit	Symbol	Access	Value	Description
31:28	RFU			-
27:24	TUNING_DAC_2_RANGE			Reference voltage of the DAC, allows to increase the resolution in case a limited output voltage is required. For max output voltage, 0x000 need to be configured (3.8 V) x111=2 V x110=3 V x100=3.45 V x000=3.8 V
23:17	TUNING_DAC_2_VALUE			Output voltage of DAC2 according to 1/128 *<TUNING_DAC_2_VALUE> * <Range in V>
16	TUNING_DAC_2_PD			0=DAC Turned off, 1=DAC enabled
15:12	RFU			-
11:8	TUNING_DAC_1_RANGE			Reference voltage of the DAC, allows to increase the resolution in case a limited output voltage is required. For max output voltage, 0x000 need to be configured (3.8 V) x111=2 V, x110=3 V x100=3.45 V x000=3.8 V

Table 107. CLIF_DAC register (address 0057h) bit description...continued

Bit	Symbol	Access	Value	Description
7:1	TUNING_DAC_1_VALUE			Output voltage of DAC1 according to $1/128 * <TUNING_DAC_1_VALUE> * <Range\ in\ V>$
0	TUNING_DAC_1_PD			0=DAC Turned off, 1=DAC enabled

9.23.51 PMU_ANA_SMPS_CTRL_REG (00058h)

Table 108. PMU_ANA_SMPS_CTRL_REG register (address 0058h) bit description

Bit	Symbol	Access	Value	Description
31:30	RFU			-
29:27	SMPS_MAXDT_SEL			SMPS max duty cycle value, valid when SMPS_MAX_DTC_BYPASS is set
26	SMPS_MAXDT_SEL_BYPASS			SMPS max duty cycle lookup table bypass
25:24	SMPS_GM			SMPS Gm setup
23:22	SMPS_RSENSE			SMPS Rsense setup
21:20	SMPS_SOFT_START			SMPS Soft Start setup
19:17	SMPS_SAWTOOTHGEN			SMPS Sawtooth generator setup
16:14	RFU			-
13:12	SMPS_PROT_UNDERSHOOT_VTH			SMPS
11:10	SMPS_REG_SPARE_0			SMPS
9:7	SMPS_PID			SMPS PID filter setup
6:1	SMPS_VDDBOOST_VOUT_SEL			SMPS Output voltage selection
0	SMPS_EN			SMPS enable

9.23.52 RXM_FREQ (00059h)

Table 109. RXM_FREQ register (address 0059h) bit description

Bit	Symbol	Access	Value	Description
31	RXM_FREQ_REG_VALID	r	-	CLIF_RXM_FREQ_REG fields are valid
30:25	RFU	r	-	-
24:16	RXM_FREQ	r	-	frequency difference between the last two consecutive measures at 1.7 MHz (multiple of 13.56MHz/4096). Signed. 2-Complement coded
15:9	RFU	r	-	-
0:8	RXM_PHASE	r	-	phase value

9.23.53 RXM_RSSI (0005Ah)

Table 110. RXM_RSSI register (address 005Ah) bit description

Bit	Symbol	Access	Reset Value	Description
31	RFU	r	-	-

Table 110. RXM_RSSI register (address 005Ah) bit description...continued

Bit	Symbol	Access	Reset Value	Description
22	RXM_RSSI_FROZEN	r	-	The RSSI value is not currently updated
21	RXM_FRQ_OK	r	-	The carrier frequency detected is OK.
20	RXM_RSSI_REG_VALID	r	-	CLIF_RXM_RSSI_REG fields are valid
19:14	RXM_HFATT	r	-	HFAtt latched with RSSI
13:0	RXM_RSSI	r	-	RSSI value

9.23.54 TEMP_SENSOR (005Bh)

Table 111. TEMP_SENSOR register (address 005Bh) bit description

Bit	Symbol	Access	Value	Description
31:16	-	R	0*,1	RFU
15-0	TEMP_SENSOR_DATA	R	0*,1	Indicates the current temperature of the chip in degree celsius. This is the actual temperature data of the sensor which is used for the overheat protection. Maximum temperature readable will be the maximum temperature threshold configured in EEPROM address 0x14.

9.23.55 TX_NOV_CALIBRATE (005Dh)

Table 112. TX_NOV_CALIBRATE register (address 005Dh) bit description

Bit	Symbol	Access	Value	Description
31:30	RFU	RW	0*,1	-
0	TX_NOV_CALIBRATE_AND_STORE_VAL	RW		Calibrates the TX NOV and stores the resulting value in EEPROM

9.23.56 SS_TX1_RTRTRANS0 (00080h)

Table 113. SS_TX1_RTRTRANS0 register (address 0080h) bit description

Bit	Symbol	Access	Value	Description
31:24	TX1_SS_RTRANS3	rw		TX1 rising transition value 3
23:16	TX1_SS_RTRANS2	rw		TX1 rising transition value 2
15:8	TX1_SS_RTRANS1	rw		TX1 rising transition value 1
7:0	TX1_SS_RTRANS0	rw		TX1 rising transition value 0

9.23.57 SS_TX1_RTRTRANS1 (00081h)

Table 114. SS_TX1_RTRTRANS1 register (address 0081h) bit description

Bit	Symbol	Access	Value	Description
31:24	TX1_SS_RTRANS7	rw		TX1 rising transition value 7
23:16	TX1_SS_RTRANS6	rw		TX1 rising transition value 6

Table 114. SS_TX1_RTRTRANS1 register (address 0081h) bit description...continued

Bit	Symbol	Access	Value	Description
15:8	TX1_SS_RTRANS5	rw		TX1 rising transition value 5
7:0	TX1_SS_RTRANS4	rw		TX1 rising transition value 4

9.23.58 SS_TX1_RTRTRANS2 (00082h)

Table 115. SS_TX1_RTRTRANS2 register (address 0082h) bit description

Bit	Symbol	Access	Value	Description
31:24	TX1_SS_RTRANS11	rw		TX1 rising transition value 11
23:16	TX1_SS_RTRANS10	rw		TX1 rising transition value 10
15:8	TX1_SS_RTRANS9	rw		TX1 rising transition value 9
7:0	TX1_SS_RTRANS8	rw		TX1 rising transition value 8

9.23.59 SS_TX1_RTRTRANS3 (00083h)

Table 116. SS_TX1_RTRTRANS0 register (address 0080h) bit description

Bit	Symbol	Access	Value	Description
31:24	TX1_SS_RTRANS15	rw		TX1 rising transition value 15
23:16	TX1_SS_RTRANS14	rw		TX1 rising transition value 14
15:8	TX1_SS_RTRANS13	rw		TX1 rising transition value 13
7:0	TX1_SS_RTRANS12	rw		TX1 rising transition value 12

9.23.60 SS_TX2_RTRTRANS0 (00084h)

Table 117. SS_TX2_RTRTRANS0 register (address 00804) bit description

Bit	Symbol	Access	Value	Description
31:24	TX2_SS_RTRANS3	rw		TX2 rising transition value 3
23:16	TX2_SS_RTRANS2	rw		TX2 rising transition value 2
15:8	TX2_SS_RTRANS1	rw		TX2 rising transition value 1
7:0	TX2_SS_RTRANS0	rw		TX2 rising transition value 0

9.23.61 SS_TX2_RTRTRANS1 (00085h)

Table 118. SS_TX2_RTRTRANS1 register (address 0085h) bit description

Bit	Symbol	Access	Value	Description
31:24	TX2_SS_RTRANS7	rw		TX2 rising transition value 7
23:16	TX2_SS_RTRANS6	rw		TX2 rising transition value 6
15:8	TX2_SS_RTRANS5	rw		TX2 rising transition value 5
7:0	TX2_SS_RTRANS4	rw		TX2 rising transition value 4

9.23.62 SS_TX2_RTRTRANS2 (00086h)

Table 119. SS_TX2_RTRTRANS2 register (address 0086h) bit description

Bit	Symbol	Access	Value	Description
31:24	TX2_SS_RTRANS11	rw		TX2 rising transition value 11
23:16	TX2_SS_RTRANS10	rw		TX2 rising transition value 10
15:8	TX2_SS_RTRANS9	rw		TX2 rising transition value 9
7:0	TX2_SS_RTRANS8	rw		TX2 rising transition value 8

9.23.63 SS_TX2_RTRTRANS3 (00087h)

Table 120. SS_TX2_RTRTRANS3 register (address 0087h) bit description

Bit	Symbol	Access	Value	Description
31:24	TX2_SS_RTRANS15	rw		TX2 rising transition value 15
23:16	TX2_SS_RTRANS14	rw		TX2 rising transition value 14
15:8	TX2_SS_RTRANS13	rw		TX2 rising transition value 13
7:0	TX2_SS_RTRANS12	rw		TX2 rising transition value 12

9.23.64 SS_TX1_FTRTRANS0 (00088h)

Table 121. SS_TX1_FTRTRANS0 register (address 0088h) bit description

Bit	Symbol	Access	Value	Description
31:24	TX1_SS_FTRANS3	rw		TX1 falling transition value 3
23:16	TX1_SS_FTRANS2	rw		TX1 falling transition value 2
15:8	TX1_SS_FTRANS1	rw		TX1 falling transition value 1
7:0	TX1_SS_FTRANS0	rw		TX1 falling transition value 0

9.23.65 SS_TX1_FTRTRANS1 (00089h)

Table 122. SS_TX1_FTRTRANS1 register (address 0089h) bit description

Bit	Symbol	Access	Value	Description
31:24	TX1_SS_FTRANS7	rw		TX1 falling transition value 7
23:16	TX1_SS_FTRANS6	rw		TX1 falling transition value 6
15:8	TX1_SS_FTRANS5	rw		TX1 falling transition value 5
7:0	TX1_SS_FTRANS4	rw		TX1 falling transition value 4

9.23.66 SS_TX1_FTRTRANS2 (0008Ah)

Table 123. SS_TX1_FTRTRANS2 register (address 008Ah) bit description

Bit	Symbol	Access	Value	Description
31:24	TX1_SS_FTRANS11	rw		TX1 rising transition value 11
23:16	TX1_SS_FTRANS10	rw		TX1 rising transition value 10
15:8	TX1_SS_FTRANS9	rw		TX1 rising transition value 9

Table 123. SS_TX1_FTRTRANS2 register (address 008Ah) bit description...continued

Bit	Symbol	Access	Value	Description
7:0	TX1_SS_FTRANS8	rw		TX1 rising transition value 8

9.23.67 SS_TX1_FTRTRANS3 (0008Bh)

Table 124. SS_TX1_FTRTRANS3 register (address 008Bh) bit description

Bit	Symbol	Access	Value	Description
31:24	TX1_SS_FTRANS15	rw		TX1 rising transition value 15
23:16	TX1_SS_FTRANS14	rw		TX1 rising transition value 14
15:8	TX1_SS_FTRANS13	rw		TX1 rising transition value 13
7:0	TX1_SS_FTRANS12	rw		TX1 rising transition value 12

9.23.68 SS_TX2_FTRTRANS0 (0008Ch)

Table 125. SS_TX2_FTRTRANS0 register (address 008Ch) bit description

Bit	Symbol	Access	Value	Description
31:24	TX2_SS_FTRANS3	rw		TX2 falling transition value 3
23:16	TX2_SS_FTRANS2	rw		TX2 falling transition value 2
15:8	TX2_SS_FTRANS1	rw		TX2 falling transition value 1
7:0	TX2_SS_FTRANS0	rw		TX2 falling transition value 0

9.23.69 SS_TX2_FTRTRANS1 (0008Dh)

Table 126. SS_TX2_FTRTRANS1 register (address 008Dh) bit description

Bit	Symbol	Access	Value	Description
31:24	TX2_SS_FTRANS7	rw		TX2 falling transition value 7
23:16	TX2_SS_FTRANS6	rw		TX2 falling transition value 6
15:8	TX2_SS_FTRANS5	rw		TX2 falling transition value 5
7:0	TX2_SS_FTRANS4	rw		TX2 falling transition value 4

9.23.70 SS_TX2_FTRTRANS2 (0008Eh)

Table 127. SS_TX2_FTRTRANS2 register (address 008Eh) bit description

Bit	Symbol	Access	Value	Description
31:24	TX2_SS_FTRANS11	rw		TX2 falling transition value 11
23:16	TX2_SS_FTRANS10	rw		TX2 falling transition value 10
15:8	TX2_SS_FTRANS9	rw		TX2 falling transition value 9
7:0	TX2_SS_FTRANS8	rw		TX2 falling transition value 8

9.23.71 SS_TX2_FTRTRANS3 (0008Fh)

Table 128. SS_TX2_FTRTRANS3 register (address 008Fh) bit description

Bit	Symbol	Access	Value	Description
31:24	TX2_SS_FTRANS15	rw		TX2 falling transition value 15
23:16	TX2_SS_FTRANS14	rw		TX2 falling transition value 14
15:8	TX2_SS_FTRANS13	rw		TX2 falling transition value 13
7:0	TX2_SS_FTRANS12	rw		TX2 falling transition value 12

9.24 EEPROM configuration description

The settings done in EEPROM are used for basic configuration which does not change frequently. Typically it is performed once during trimming or configuration of a product. The EEPROM has a limited number of erase/write cycles that can be performed. This means, that configurations that change frequently must be performed in standard registers which do not keep their value during reset and power-off.

This section describes the EEPROM configuration of the PN5190B1.

Writing to the EEPROM has to be performed with Read-Modify-Write for all memory addresses which contain RFU bits.

9.24.1 EEPROM configuration overview

Table 129. EEPROM CONFIGURATION REGISTER

Address (HEX)	Name
0	DCDC_PWR_CONFIG
1	DCDC_CONFIG
2	TXLDO_CONFIG
6	TXLDO_VDDPA_HIGH
7	TXLDO_VDDPA_LOW
8	TXLDO_VDDPA_MAX_RDR
9	TXLDO_VDDPA_HIGH_MAX_CARD
A	BOOST_DEFAULT_VOLTAGE
10	XTAL_CONFIG
11	XTAL_TIMEOUT
12	CLK_INPUT_FREQ
13	XTAL_CHECK_DELAY
14	TEMP_WARNING
15	RFU
16	ENABLE_GPIO0_ON_OVERTEMP
17	RFU
18	RFU

Table 129. EEPROM CONFIGURATION REGISTER...continued

Address (HEX)	Name
19	RFU
1A	RFU
1B	RFU
1C	RFU
1D	RFU
1E	RFU
1F	RFU
20	RFU
21	RFU
22	RESIDUAL_AMP_LEVEL_A106
23	EDGE_TYPE_A106
24	EDGE_STYLE_A106
25	EDGE_LENGTH_A106
26	RESIDUAL_AMP_LEVEL_A212
27	EDGE_TYPE_A212
28	EDGE_STYLE_A212
29	EDGE_LENGTH_A212
2A	RESIDUAL_AMP_LEVEL_A424
2B	EDGE_TYPE_A424
2C	EDGE_STYLE_A424
2D	EDGE_LENGTH_A424
2E	RESIDUAL_AMP_LEVEL_A848
2F	EDGE_TYPE_A848
30	EDGE_STYLE_A848
31	EDGE_LENGTH_A848
32	RESIDUAL_AMP_LEVEL_B106
33	EDGE_TYPE_B106
34	EDGE_STYLE_B106
35	EDGE_LENGTH_B106
36	RESIDUAL_AMP_LEVEL_B212
37	EDGE_TYPE_B212
38	EDGE_STYLE_B212
39	EDGE_LENGTH_B212
3A	RESIDUAL_AMP_LEVEL_B424
3B	EDGE_TYPE_B424
3C	EDGE_STYLE_B424

Table 129. EEPROM CONFIGURATION REGISTER...continued

Address (HEX)	Name
3D	EDGE_LENGTH_B424
3E	RESIDUAL_AMP_LEVEL_B848
3F	EDGE_TYPE_A848
40	EDGE_STYLE_A848
41	EDGE_LENGTH_A848
42	RESIDUAL_AMP_LEVEL_F212
43	EDGE_TYPE_F212
44	EDGE_STYLE_F212
45	EDGE_LENGTH_F212
46	RESIDUAL_AMP_LEVEL_F424
47	EDGE_TYPE_F424
48	EDGE_STYLE_F424
49	EDGE_LENGTH_F424
4A	RESIDUAL_AMP_LEVEL_V100_26
4B	EDGE_TYPE_V100_26
4C	EDGE_STYLE_V100_26
4D	EDGE_LENGTH_V100_26
4E	RESIDUAL_AMP_LEVEL_V100_53
4F	EDGE_TYPE_V100_53
50	EDGE_STYLE_V100_53
51	EDGE_LENGTH_V100_53
52	RESIDUAL_AMP_LEVEL_V100_106
53	EDGE_TYPE_V100_106
54	EDGE_STYLE_V100_106
55	EDGE_LENGTH_V100_106
56	RESIDUAL_AMP_LEVEL_V100_212
57	EDGE_TYPE_V100_212
58	EDGE_STYLE_V100_212
59	EDGE_LENGTH_V100_212
5A	RESIDUAL_AMP_LEVEL_V10_26
5B	EDGE_TYPE_V10_26
5C	EDGE_STYLE_V10_26
5D	EDGE_LENGTH_V10_26
5E	RESIDUAL_AMP_LEVEL_V10_53
5F	EDGE_TYPE_V10_53
60	EDGE_STYLE_V10_53

Table 129. EEPROM CONFIGURATION REGISTER...continued

Address (HEX)	Name
61	EDGE_LENGTH_V10_53
62	RESIDUAL_AMP_LEVEL_V10_106
63	EDGE_TYPE_V10_106
64	EDGE_STYLE_V10_106
65	EDGE_LENGTH_V10_106
66	RESIDUAL_AMP_LEVEL_V10_212
67	EDGE_TYPE_V10_212
68	EDGE_STYLE_V10_212
69	EDGE_LENGTH_V10_212
66	RESIDUAL_AMP_LEVEL_V10_212
67	EDGE_TYPE_V10_212
68	EDGE_STYLE_V10_212
69	EDGE_LENGTH_V10_212
6A	RESIDUAL_AMP_LEVEL_180003m3_tari18p88
6B	EDGE_TYPE_180003m3_tari18p88
6C	EDGE_STYLE_180003m3_tari18p88
6D	EDGE_LENGTH_180003m3_tari18p88
6E	RESIDUAL_AMP_LEVEL_180003m3_tari9p44
6F	EDGE_TYPE_180003m3_tari9p44
70	EDGE_STYLE_180003m3_tari9p44
71	EDGE_LENGTH_180003m3_tari9p44
72	RESIDUAL_AMP_LEVEL_B_PRIME_106
73	EDGE_TYPE_B_PRIME_106
74	EDGE_STYLE_B_PRIME_106
75	EDGE_LENGTH_B_PRIME_106
76	DPC_CONFIG
77	DPC_TARGET_CURRENT
79	DPC_HYSTERESIS_LOADING
7A	RFU
7B	RFU
7C	DPC_HYSTERESIS_UNLOADING
7D	DPC_TXLDOVDDPALow
7E	DPC_TXGSN
7F	DPC_RDON_Control
80	DPC_InitialRDOOn_RFOOn
81	RFU

Table 129. EEPROM CONFIGURATION REGISTER...continued

Address (HEX)	Name
83	RFU
85	RFU
87	DPC_GUARD_TIME
88	DPC_ENABLE_DURING_FDT
89	DPC_GUARD_TIME_AFTER_RX
8A	RFU
8B	DPC_LOOKUP_TABLE
137	ARC_CONFIG
139	ARC_VDDPA
13E	ARC_RM_A106
148	ARC_RM_A212
152	ARC_RM_A424
15C	ARC_RM_A848
166	ARC_RM_B106
170	ARC_RM_B212
17A	ARC_RM_B424
184	ARC_RM_B848
18E	ARC_RM_F212
198	ARC_RM_F424
1A2	ARC_RM_V6p6
1AC	ARC_RM_V26
1B6	ARC_RM_V53
1C0	ARC_RM_V106
1CA	ARC_RM_V212
1D4	ARC_RM_18003m3_SC424_4MAN
1DE	ARC_RM_18003m3_SC848_2MAN
1E8	ARC_RM_18003m3_SC848_4MAN
1F2	ARC_RM_18003m3_SC848_2MAN
1FC	ARC_RM_AI106
206	ARC_RM_AI212
210	ARC_RM_AI424
2B2	RF_DEBOUNCE_TIMEOUT
2B3	SENSE_RES
2B5	NFC_ID1
2B8	SEL_RES
2B9	FELICA_POLL_RES

Table 129. EEPROM CONFIGURATION REGISTER...continued

Address (HEX)	Name
2CB	RANDOM_UID_ENABLE
2CC	MFC_AUTH_TIMEOUT
2DA	RSSI_TIMER
2DC	RSSI_TIMER_FIRST_PERIOD
2DE	RSSI_CTRL_00_AB
2DF	RSSI_NB_ENTRIES_AB
2E0	RSSI_THRESHOLD_PHASE_TABLE
3A2	TX_PARAM_ENTRY_TABLE
492	LPCD_AVG_SAMPLES
494	LPCD_RSSI_TARGET
496	LPCD_RSSI_HYST
49B	RFU
49E	LPCD_THRESHOLD
4B5	LPCD_VDDPA
4BF	ULPCD_VDDPA_CTRL
4C2	ULPCD_TIMING_CTRL
4C6	ULPCD_VOLTAGE_CTRL
4C7	RFU
4C9	ULPCD_RSSI_GUARD_TIME
4CA	ULPCD_RSSI_SAMPLE_CFG
4CB	ULPCD_THRESH_LVL
4CC	ULPCD_GPIO3
559	TXIRQ_GUARDTIME
55D	FDT_DEFAULTVAL
561	RXIRQ_GUARDTIME
562-6D2	RFU
6D3	NFCLD_RFLD_Valid
6D4-ABB	RFU
ABC	CurrentSensorTrimConfig
ABD-BD9	RFU
BDA	CORRECTION_ENTRY_TABLE
C03	RTRANS_FRTANS_TABLE
C83	CFG_NOV_CAL
C84	NOV_CAL_VAL1
C85	NOV_CAL_VAL2
C86	NOV_CAL_THRESHOLD

Table 129. EEPROM CONFIGURATION REGISTER...continued

Address (HEX)	Name
C87	NOV_CAL_OFFSET1
C8B	NOV_CAL_OFFSET2
C8F	VDDPA_DISCHARGE
C9D	ARC_RM_A106_FDT
CA8-CC4	RFU
CC5	Tx_Symbol23_Mod_Reg_BR_53
CC9	Tx_Data_Mod_Reg_BR_53
CCD	Tx_Symbol23_Mod_Reg_BR_106
CD1	Tx_Data_Mod_Reg_BR_106
CD5	Tx_Symbol23_Mod_Reg_BR_212
CD9	Tx_Data_Mod_Reg_BR_212
CDDh-1400h	DO NOT TOUCH OR OVERWRITE, INTERNAL SETTINGS

9.24.2 DCDC_PWR_CONFIG (0000h)

Table 130. PWR_CONFIG (address 0000h) EEPROM configuration bit description

Address (hex)	Function	Bit	Description
0	DC-DC usage in card mode	7	0b: DC-DC is not powered and set to bypass 1b: DC-DC is powered and not bypassed
	DC-DC usage in reader mode	6	0b: DC-DC is not powered and set to bypass 1b: DC-DC is powered and not bypassed
	RFU	5	Do not touch, default value 01b
	VUP input voltage	4..0	0x00: Not connected or 0 V 0x01: VUP supplied by PN5190B1 itself (pin VUP_TX connected to VBAT/VBATPWR) 0x02: Internal DC-DC with fixed VDDBOOST 0x04: Internal DC-DC with auto by pass and variable boost w.r.t VDDPA (internal DPC controls VDDBOOST): DC-DC goes into pass through mode when the VDDPA goes below 3.3 V. When VDDPA is greater than 3.3 V, the DC-DC is configured to boost voltage in range of 3.3 V to 6 V. 0x05 - 0x09: RFU 0x10: external supply

9.24.3 DCDC_CONFIG (0001h)

Table 131. DCDC_CONFIG (address 0001h) EEPROM configuration bit description

Address (hex)	Function	Bit	Description
1	DC-DC configuration	7:5	RFU

Table 131. DCDC_CONFIG (address 0001h) EEPROM configuration bit description...continued

Address (hex)	Function	Bit	Description
		4	DC-DC passthrough feature is: 0: Not supported (Vout = 0v or +5v) 1: Supported (Vout = 0v, Vin or +5v)
		3	Use of DC-DC for LPCD (attention: not ULPCD) 1: enabled 0: disabled
		2:0	RFU

9.24.4 TXLDO_CONFIG (0002h)

Table 132. TXLDO_CONFIG (address 0002h) EEPROM configuration bit description

Address (hex)	Function	Bit	Description
2	TXLDO Configuration	31:12	RFU
		11:10	RFU
		9:4	TXLDO output voltage VDDPA_1V50 /* 0x00 */ VDDPA_1V60, /* 0x01 */ VDDPA_1V70, /* 0x02 */ VDDPA_1V80, /* 0x03 */ VDDPA_1V90, /* 0x04 */ VDDPA_2V00, /* 0x05 */ VDDPA_2V10, /* 0x06 */ VDDPA_2V20, /* 0x07 */ VDDPA_2V30, /* 0x08 */ VDDPA_2V40, /* 0x09 */ VDDPA_2V50, /* 0x0A */ VDDPA_2V60, /* 0x0B */ VDDPA_2V70, /* 0x0C */ VDDPA_2V80, /* 0x0D */ VDDPA_2V90, /* 0x0E */ VDDPA_3V00, /* 0x0F */ VDDPA_3V10, /* 0x10 */ VDDPA_3V20, /* 0x11 */ VDDPA_3V30, /* 0x12 */ VDDPA_3V40, /* 0x13 */ VDDPA_3V50, /* 0x14 */ VDDPA_3V60, /* 0x15 */ VDDPA_3V70, /* 0x16 */ VDDPA_3V80, /* 0x17 */ VDDPA_3V90, /* 0x18 */ VDDPA_4V00, /* 0x19 */ VDDPA_4V10, /* 0x1A */ VDDPA_4V20, /* 0x1B */ VDDPA_4V30, /* 0x1C */ VDDPA_4V40, /* 0x1D */ VDDPA_4V50, /* 0x1E */ VDDPA_4V60, /* 0x1F */ VDDPA_4V70, /* 0x20 */ VDDPA_4V80, /* 0x21 */ VDDPA_4V90, /* 0x22 */ VDDPA_5V00, /* 0x23 */ VDDPA_5V10, /* 0x24 */ VDDPA_5V20, /* 0x25 */ VDDPA_5V30, /* 0x26 */ VDDPA_5V40, /* 0x27 */ VDDPA_5V50, /* 0x28 */ VDDPA_5V60, /* 0x29 */ VDDPA_5V70, /* 0x2A */
		3:1	RFU
		0	Enable TXLDO 0b: disabled - no voltage output of the TXLDO 1b: enabled - regulated output of the TXLDO according to bits 9:4

9.24.5 TXLDO_VDDPA_HIGH (0006h)

Table 133. TXLDO_VDDPA_HIGH (address 0006h) EEPROM configuration bit description

Address Function (hex)	Function	Bit	Description
6	TXLDO output: initial voltage in case the DPC is used. Applies directly at the beginning of the RF-field-on before any DPC regulation takes place.	7:0	0x00: 1V50 0x01: 1V60 0x02: 1V70 0x03: 1V80 0x04: 1V90 0x05: 2V00 0x06: 2V10 0x07: 2V20 0x08: 2V30 0x09: 2V40 0x0A: 2V50 0x0B: 2V60 0x0C: 2V70 0x0D: 2V80 0x0E: 2V90 0x0F: 3V00 0x10: 3V10 0x11: 3V20 0x12: 3V30 0x13: 3V40 0x14: 3V50 0x15: 3V60 0x16: 3V70 0x17: 3V80 0x18: 3V90 0x19: 4V00 0x1A: 4V10 0x1B: 4V20 0x1C: 4V30 0x1D: 4V40 0x1E: 4V50 0x1F: 4V60 0x20: 4V70 0x21: 4V80 0x22: 4V90 0x23: 5V00 0x24: 5V10 0x25: 5V20 0x26: 5V30 0x27: 5V40 0x28: 5V50 0x29: 5V60 0x2A: 5V70

9.24.6 TXLDO_VDDPA_LOW (0007h)

Table 134. TXLDO_VDDPA_LOW (address 0007h) EEPROM configuration bit description

Address (hex)	Function	Bit	Description
7	TXLDO output voltage in case the DPC is disabled and not used.	7:0	0x00: 1V50 0x01: 1V60 0x02: 1V70 0x03: 1V80 0x04: 1V90 0x05: 2V00 0x06: 2V10 0x07: 2V20 0x08: 2V30 0x09: 2V40 0x0A: 2V50 0x0B: 2V60 0x0C: 2V70 0x0D: 2V80 0x0E: 2V90 0x0F: 3V00 0x10: 3V10 0x11: 3V20 0x12: 3V30 0x13: 3V40 0x14: 3V50 0x15: 3V60 0x16: 3V70 0x17: 3V80 0x18: 3V90 0x19: 4V00 0x1A: 4V10 0x1B: 4V20 0x1C: 4V30 0x1D: 4V40 0x1E: 4V50 0x1F: 4V60 0x20: 4V70 0x21: 4V80 0x22: 4V90 0x23: 5V00 0x24: 5V10 0x25: 5V20 0x26: 5V30 0x27: 5V40 0x28: 5V50 0x29: 5V60 0x2A: 5V70

9.24.7 TXLDO_VDDPA_MAX_RDR (0008h)

Table 135. TXLDO_VDDPA_MAX_RDR (address 0008h) EEPROM configuration bit description

Address (hex)	Function	Bit	Description
8	VDDPA maximum output voltage in case the DPC is enabled in reader mode	7:0	0x00: 1V50 0x01: 1V60 0x02: 1V70 0x03: 1V80 0x04: 1V90 0x05: 2V00 0x06: 2V10 0x07: 2V20 0x08: 2V30 0x09: 2V40 0x0A: 2V50 0x0B: 2V60 0x0C: 2V70 0x0D: 2V80 0x0E: 2V90 0x0F: 3V00 0x10: 3V10 0x11: 3V20 0x12: 3V30 0x13: 3V40 0x14: 3V50 0x15: 3V60 0x16: 3V70 0x17: 3V80 0x18: 3V90 0x19: 4V00 0x1A: 4V10 0x1B: 4V20 0x1C: 4V30 0x1D: 4V40 0x1E: 4V50 0x1F: 4V60 0x20: 4V70 0x21: 4V80 0x22: 4V90 0x23: 5V00 0x24: 5V10 0x25: 5V20 0x26: 5V30 0x27: 5V40 0x28: 5V50 0x29: 5V60 0x2A: 5V70

9.24.8 TXLDO_VDDPA_MAX_CARD (0009h)

Table 136. TXLDO_VDDPA_MAX_CARD (address 0009h) EEPROM configuration bit description

Address (hex)	Function	Bit	Description
9	VDDPA maximum output voltage in case the APC is enabled in card mode	7:0	0x00: 1V50 0x01: 1V60 0x02: 1V70 0x03: 1V80 0x04: 1V90 0x05: 2V00 0x06: 2V10 0x07: 2V20 0x08: 2V30 0x09: 2V40 0x0A: 2V50 0x0B: 2V60 0x0C: 2V70 0x0D: 2V80 0x0E: 2V90 0x0F: 3V00 0x10: 3V10 0x11: 3V20 0x12: 3V30 0x13: 3V40 0x14: 3V50 0x15: 3V60 0x16: 3V70 0x17: 3V80 0x18: 3V90 0x19: 4V00 0x1A: 4V10 0x1B: 4V20 0x1C: 4V30 0x1D: 4V40 0x1E: 4V50 0x1F: 4V60 0x20: 4V70 0x21: 4V80 0x22: 4V90 0x23: 5V00 0x24: 5V10 0x25: 5V20 0x26: 5V30 0x27: 5V40 0x28: 5V50 0x29: 5V60 0x2A: 5V70

9.24.9 BOOST_DEFAULT_VOLTAGE (000Ah)

Table 137. BOOST_DEFAULT_VOLTAGE (address 000Ah) EEPROM configuration bit description

Address (hex)	Function	Bit	Description
0A	DC-DC configuration	7:0	VDDBOOST output voltage in case of DC-DC with fixed VDDBOOST is enabled (PWR_CONFIG) 0x00: 3.1 V 0x01: 3.2 V 0x02: 3.3 V 0x03: 3.4 V 0x04: 3.5 V 0x05: 3.6 V 0x06: 3.7 V 0x07: 3.8 V 0x08: 3.9 V 0x09: 4.0 V 0x0A: 4.1 V 0x0B: 4.2 V 0x0C: 4.3 V 0x0D: 4.4 V 0x0E: 4.5 V 0x0F: 4.6 V 0x10: 4.7 V 0x11: 4.8 V 0x12: 4.9 V 0x13: 5.0 V 0x14: 5.1 V 0x15: 5.2 V 0x16: 5.3 V 0x17: 5.4 V 0x18: 5.5 V 0x19: 5.6 V 0x1A: 5.7 V 0x1B: 5.8 V 0x1C: 5.9 V 0x1D: 6.0 V all other values: RFU

9.24.10 XTAL_CONFIG (0010h)

Table 138. XTAL_CONFIG (address 0010h) EEPROM configuration bit description

Address (hex)	Function	Bit	Description
10	Configuration for the XTAL startup procedure	7:1	RFU
		0	Crystal recalibration start after wake-up from standby 1: enable 0: disable

9.24.11 XTAL_TIMEOUT (0011h)

Table 139. XTAL_TIMEOUT (address 0011h) EEPROM configuration bit description

Address (hex)	Function	Bit	Description
11	Configuration for the XTAL startup procedure	7:0	Timeout for XTAL to be ready (in *128us), if the timeout happens, an XTAL error event will be raised. This configuration does not speed up the boot time.

9.24.12 CLK_INPUT_FREQ (0012h)

Table 140. CLK_INPUT_FREQ (address 0012h) EEPROM configuration bit description

Address (hex)	Function	Bit	Description
12	Configuration for the PLL input clock frequency	7:4	RFU
		3:0	0010b: 24 MHz 0011b: 32 MHz 0100b: 48 MHz 1000b: XTAL 27.12 MHz All others: RFU

9.24.13 XTAL_CHECK_DELAY (0013h)

Correct Crystal clocking is detected by locking the crystal to the PLL. This allows the system to start quick independent from the crystal startup time. High-quality crystals will start up typically fast and allow by this optimized current consumption, e.g. during ULPCD.

A user needs to find an optimized balance between retry numbers of checking for a proper locking and the interval for checking for a locked PLL.

This allows to configure a timeout value for locking the crystal to the PLL. The timeout value is defined by **Retry_number** x **Interval**. If the timeout is reached, a clock error is raised.

Table 141. XTAL_CHECK_DELAY (address 0013h) EEPROM configuration bit description

Address (hex)	Function	Bit	Description
13	Retry_number	7:5	Max Number of retries before a clock error is raised
	Interval	4:0	Interval which is used to check if XTAL is ready (unit is 256/fc, e.g. ~18.8 us). This is the time to try to lock the PLL, a stable crystal clock is required for locking. If the PLL is not locked, a next retry to lock the PLL will be done after this interval. This value can be used to optimize the startup time dependent on the crystal characteristics. This is important, e.g., for optimization of the LPCD and ULPCD.

9.24.14 TEMP_WARNING (0014h)

Table 142. TEMP_WARNING (address 0014h) EEPROM configuration bit description

Address (hex)	Function	Bit	Description
14	CLIF & PMU temperature warning	7:6	PMU high threshold (0: disabled, 1:114degC, 2:125degC, 3:130degC)
		5:4	PMU low threshold (0: disabled, 1:114degC, 2:125degC, 3:130degC)
		3:2	high threshold (0: disabled, 1:114 °C, 2:125 °C, 3:130 °C) - in case temp sensor is triggered, transmitter and VDDPALDO are shut down, system goes in low-power mode - default is 130 °C. This event is not indicated by an IRQ to the host, instead GPIO0 with configurable high/low polarity is used to indicate this critical event (Register PAD_CONFIG 0x4B). To enable this event on GPIO0, the EEPROM register ENABLE_GPIO0_ON_OVERTEMP (0054h) must be set.
		1:0	low threshold (0: disabled, 1:114 °C, 2:125 °C, 3:130 °C) - in case temperature sensed is lower than threshold, system wakes up from low-power mode, a temp wake-up event is issued to the host - default is 114 °C. This event is not indicated by an IRQ to the host, instead GPIO0 with configurable high/low polarity is used to indicate this critical event (Register PAD_CONFIG 0x52). To enable this event on GPIO0, the EEPROM register ENABLE_GPIO0_ON_OVERTEMP (0054h) must be set.

9.24.15 ENABLE_GPIO0_ON_OVERTEMP (0016h)

Table 143. ENABLE_GPIO0_ON_OVERTEMP (address 0016h) EEPROM configuration bit description

Address (hex)	Function	Bit	Description
16	RFU	7..1	-
	Set/Clear GPIO0 during over temperature.	0	If set, the GPIO0 is used to indicate a temperature event. The temperature warning levels are configured in the EEPROM Register TEMP_WARNING (0048h).

9.24.16 RESIDUAL_AMPL_LEVEL_A106 (0022h)

Table 144. RESIDUAL_AMPL_LEVEL_A106 (address 0022h) EEPROM configuration bit description

Address (hex)	Function	Bit	Description
22	Transmitter shaping configuration	7:0	Residual amplitude level 00: 0% carrier FF: 100% carrier

9.24.17 EDGE_TYPE_A106 (0023h)

Table 145. EDGE_TYPE_A106 (address 0023h) EEPROM configuration bit description

Address (hex)	Function	Bit	Description
23	Transmitter shaping configuration	7:4	<p>Definition of edge transition style of falling edge</p> <p>Defines style of edge transition:</p> <p>Firmware based shaping:</p> <p>1: linear transition between two amplitude levels</p> <p>2: two linear transitions between amplitude levels</p> <p>3: three linear transitions between amplitude levels</p> <p>Lookup table based shaping:</p> <p>4: lookup table-based transition, no automatic adaptation based on VDDPA</p> <p>5: lookup table-based transition, automatic adaptation based on VDDPA including sCorrection</p> <p>6: lookup table-based transition, automatic adaptation based on VDDPA but no sCorrection</p> <p>others: RFU</p>
		3:0	<p>Definition of edge transition style of rising edge</p> <p>Defines style of edge transition:</p> <p>Firmware based shaping:</p> <p>1: linear transition between two amplitude levels</p> <p>2: two linear transitions between amplitude levels</p> <p>3: three linear transitions between amplitude levels Others: RFU</p> <p>Lookup table based shaping:</p> <p>4: lookup table-based transition, no automatic adaptation based on VDDPA</p> <p>5: lookup table-based transition, automatic adaptation based on VDDPA including sCorrection</p> <p>6: lookup table-based transition, automatic adaptation based on VDDPA but no sCorrection</p> <p>others: RFU</p>

9.24.18 EDGE_STYLE_A106 (0024h)

Table 146. EDGE_STYLE_A106 (address 0024h) EEPROM configuration bit description

Address (hex)	Function	Bit	Description
24	RFU	7	-
	Transmitter shaping configuration falling edge	6:4	<p>If EDGE_TYPE is 1, 2 or 3: Time constant configuration of falling edge (depends on edge style)</p> <p>If EDGE_TYPE is 4,5,6: This number is the lookup table which shall be used of falling edge (0,1,2,3)</p>
	RFU	3	-
	Transmitter shaping configuration rising edge	2:0	<p>If EDGE_TYPE is 1, 2 or 3: Time constant configuration of rising edge (depends on edge style)</p> <p>If EDGE_TYPE is 4,5,6: This number is the lookup table which shall be used of rising edge (0,1,2,3)</p>

9.24.19 EDGE_LENGTH_A106 (0025h)

Table 147. EDGE_LENGTH_A106 (address 0025h) EEPROM configuration bit description

Address (hex)	Function	Bit	Description
25	Transmitter shaping configuration	7	Scaling of edge transition by factor 2 of rising/falling edge (refers to both rising and falling edge at the same time) 0=disabled (1 transition state = one carrier cycle) 1=enabled (1 transition state = two carrier cycles)
		6:5	RFU
		4:0	Number of active transition states in rising and falling edge pattern (refers to both rising and falling edge at the same time)

9.24.20 RESIDUAL_AMPL_LEVEL_A212 (0026h)

Table 148. RESIDUAL_AMPL_LEVEL_A212 (address 0026h) EEPROM configuration bit description

Address (hex)	Function	Bit	Description
22	Transmitter shaping configuration	7:0	Residual amplitude level 00: 0 % carrier FF: 100 % carrier

9.24.21 EDGE_TYPE_A212 (0027h)

Table 149. EDGE_TYPE_A212 (address 0027h) EEPROM configuration bit description

Address (hex)	Function	Bit	Description
23	Transmitter shaping configuration	7:4	Definition of edge transition style of falling edge Defines style of edge transition: Firmware based shaping: 1: linear transition between two amplitude levels 2: two linear transitions between amplitude levels 3: three linear transitions between amplitude levels Others: RFU Lookup table based shaping: 4: lookup table-based transition, no automatic adaptation based on VDDPA 5: lookup table-based transition, automatic adaptation based on VDDPA including sCorrection 6: lookup table-based transition, automatic adaptation based on VDDPA but no sCorrection others: RFU

Table 149. EDGE_TYPE_A212 (address 0027h) EEPROM configuration bit description...continued

Address (hex)	Function	Bit	Description
		3:0	Definition of edge transition style of rising edge Defines style of edge transition: Firmware based shaping: 1: linear transition between two amplitude levels 2: two linear transitions between amplitude levels 3: three linear transitions between amplitude levels Others: RFU Lookup table based shaping: 4: lookup table-based transition, no automatic adaptation based on VDDPA 5: lookup table-based transition, automatic adaptation based on VDDPA including sCorrection 6: lookup table-based transition, automatic adaptation based on VDDPA but no sCorrection others: RFU

9.24.22 EDGE_STYLE_A212 (0028h)

Table 150. EDGE_STYLE_A212 (address 0028h) EEPROM configuration bit description

Address (hex)	Function	Bit	Description
24	RFU	7	-
	Transmitter shaping configuration falling edge	6:4	If EDGE_TYPE is 1, 2 or 3: Time constant configuration of falling edge (depends on edge style) If EDGE_TYPE is 4,5,6: This number is the lookup table which shall be used of falling edge (0,1,2,3)
	RFU	3	-
	Transmitter shaping configuration rising edge	2:0	If EDGE_TYPE is 1, 2 or 3: Time constant configuration of rising edge (depends on edge style) If EDGE_TYPE is 4,5,6: This number is the lookup table which shall be used of rising edge (0,1,2,3)

9.24.23 EDGE_LENGTH_A212 (0029h)

Table 151. EDGE_LENGTH_A212 (address 0029h) EEPROM configuration bit description

Address (hex)	Function	Bit	Description
25	Transmitter shaping configuration	7	Scaling of edge transition by factor 2 of rising/falling edge (refers to both rising and falling edge at the same time) 0=disabled (1 transition state = one carrier cycle) 1=enabled (1 transition state = two carrier cycles)
		6:5	RFU
		4:0	Number of active transition states in rising and falling edge pattern (refers to both rising and falling edge at the same time)

9.24.24 RESIDUAL_AMPL_LEVEL_A424 (002Ah)

Table 152. RESIDUAL_AMPL_LEVEL_A424 (address 002Ah) EEPROM configuration bit description

Address (hex)	Function	Bit	Description
22	Transmitter shaping configuration	7:0	Residual amplitude level 00: 0% carrier FF: 100% carrier

9.24.25 EDGE_TYPE_A424 (002Bh)

Table 153. EDGE_TYPE_A424 (address 002Bh) EEPROM configuration bit description

Address (hex)	Function	Bit	Description
23	Transmitter shaping configuration	7:4	Definition of edge transition style of falling edge Defines style of edge transition: Firmware based shaping: 1: linear transition between two amplitude levels 2: two linear transitions between amplitude levels 3: three linear transitions between amplitude levels Others: RFU Lookup table based shaping: 4: lookup table-based transition, no automatic adaptation based on VDDPA 5: lookup table-based transition, automatic adaptation based on VDDPA including sCorrection 6: lookup table-based transition, automatic adaptation based on VDDPA but no sCorrection others: RFU
		3:0	Definition of edge transition style of rising edge Defines style of edge transition: Firmware based shaping: 1: linear transition between two amplitude levels 2: two linear transitions between amplitude levels 3: three linear transitions between amplitude levels Others: RFU Lookup table based shaping: 4: lookup table-based transition, no automatic adaptation based on VDDPA 5: lookup table-based transition, automatic adaptation based on VDDPA including sCorrection 6: lookup table-based transition, automatic adaptation based on VDDPA but no sCorrection others: RFU

9.24.26 EDGE_STYLE_A424 (002Ch)

Table 154. EDGE_STYLE_A424 (address 002Ch) EEPROM configuration bit description

Address (hex)	Function	Bit	Description
24	RFU	7	-

Table 154. EDGE_STYLE_A424 (address 002Ch) EEPROM configuration bit description...continued

Address (hex)	Function	Bit	Description
	Transmitter shaping configuration falling edge	6:4	If EDGE_TYPE is 1, 2 or 3: Time constant configuration of falling edge (depends on edge style) If EDGE_TYPE is 4,5,6: This number is the lookup table which shall be used of falling edge (0,1,2,3)
	RFU	3	-
	Transmitter shaping configuration rising edge	2:0	If EDGE_TYPE is 1, 2 or 3: Time constant configuration of rising edge (depends on edge style) If EDGE_TYPE is 4,5,6: This number is the lookup table which shall be used of rising edge (0,1,2,3)

9.24.27 EDGE_LENGTH_A424 (002Dh)

Table 155. EDGE_LENGTH_A424 (address 002Ch) EEPROM configuration bit description

Address (hex)	Function	Bit	Description
25	Transmitter shaping configuration	7	Scaling of edge transition by factor 2 of rising/falling edge (refers to both rising and falling edge at the same time) 0=disabled (1 transition state = one carrier cycle) 1=enabled (1 transition state = two carrier cycles)
		6:5	RFU
		4:0	Number of active transition states in rising and falling edge pattern (refers to both rising and falling edge at the same time)

9.24.28 RESIDUAL_AMPL_LEVEL_A848 (002Eh)

Table 156. RESIDUAL_AMPL_LEVEL_A848 (address 002Eh) EEPROM configuration bit description

Address (hex)	Function	Bit	Description
22	Transmitter shaping configuration	7:0	Residual amplitude level 00: 0 % carrier FF: 100 % carrier

9.24.29 EDGE_TYPE_A848 (002Fh)

Table 157. EDGE_TYPE_A848 (address 002Fh) EEPROM configuration bit description

Address (hex)	Function	Bit	Description
23	Transmitter shaping configuration	7:4	Definition of edge transition style of falling edge Defines style of edge transition: Firmware based shaping: 1: linear transition between two amplitude levels 2: two linear transitions between amplitude levels 3: three linear transitions between amplitude levels Others: RFU Lookup table based shaping: 4: lookup table-based transition, no automatic adaptation based on VDDPA 5: lookup table-based transition, automatic adaptation based on VDDPA including sCorrection 6: lookup table-based transition, automatic adaptation based on VDDPA but no sCorrection others: RFU
		3:0	Definition of edge transition style of rising edge Defines style of edge transition: Firmware based shaping: 1: linear transition between two amplitude levels 2: two linear transitions between amplitude levels 3: three linear transitions between amplitude levels Others: RFU Lookup table based shaping: 4: lookup table-based transition, no automatic adaptation based on VDDPA 5: lookup table-based transition, automatic adaptation based on VDDPA including sCorrection 6: lookup table-based transition, automatic adaptation based on VDDPA but no sCorrection others: RFU

9.24.30 EDGE_STYLE_A848 (0030h)

Table 158. EDGE_STYLE_A848 (address 0030h) EEPROM configuration bit description

Address (hex)	Function	Bit	Description
24	RFU	7	-
	Transmitter shaping configuration falling edge	6:4	If EDGE_TYPE is 1, 2 or 3: Time constant configuration of falling edge (depends on edge style) If EDGE_TYPE is 4,5,6: This number is the lookup table which shall be used of falling edge (0,1,2,3)
	RFU	3	-
	Transmitter shaping configuration rising edge	2:0	If EDGE_TYPE is 1, 2 or 3: Time constant configuration of rising edge (depends on edge style) If EDGE_TYPE is 4,5,6: This number is the lookup table which shall be used of rising edge (0,1,2,3)

9.24.31 EDGE_LENGTH_A848 (0031h)

Table 159. EDGE_LENGTH_A848 (address 0031h) EEPROM configuration bit description

Address (hex)	Function	Bit	Description
25	Transmitter shaping configuration	7	Scaling of edge transition by factor 2 of rising/falling edge (refers to both rising and falling edge at the same time) 0=disabled (1 transition state = one carrier cycle) 1=enabled (1 transition state = two carrier cycles)
		6:5	RFU
		4:0	Number of active transition states in rising and falling edge pattern (refers to both rising and falling edge at the same time)

9.24.32 RESIDUAL_AMPL_LEVEL_B106 (0032h)

Table 160. RESIDUAL_AMPL_LEVEL_B106 (address 0032h) EEPROM configuration bit description

Address (hex)	Function	Bit	Description
22	Transmitter shaping configuration	7:0	Residual amplitude level 00: 0 % carrier FF: 100 % carrier

9.24.33 EDGE_TYPE_B106 (0033h)

Table 161. EDGE_TYPE_B106 (address 0033h) EEPROM configuration bit description

Address (hex)	Function	Bit	Description
23	Transmitter shaping configuration	7:4	Definition of edge transition style of falling edge Defines style of edge transition: Firmware based shaping: 1: linear transition between two amplitude levels 2: two linear transitions between amplitude levels 3: three linear transitions between amplitude levels Others: RFU Lookup table based shaping: 4: lookup table-based transition, no automatic adaptation based on VDDPA 5: lookup table-based transition, automatic adaptation based on VDDPA including sCorrection 6: lookup table-based transition, automatic adaptation based on VDDPA but no sCorrection others: RFU

Table 161. EDGE_TYPE_B106 (address 0033h) EEPROM configuration bit description...continued

Address (hex)	Function	Bit	Description
		3:0	Definition of edge transition style of rising edge Defines style of edge transition: Firmware based shaping: 1: linear transition between two amplitude levels 2: two linear transitions between amplitude levels 3: three linear transitions between amplitude levels Others: RFU Lookup table based shaping: 4: lookup table-based transition, no automatic adaptation based on VDDPA 5: lookup table-based transition, automatic adaptation based on VDDPA including sCorrection 6: lookup table-based transition, automatic adaptation based on VDDPA but no sCorrection others: RFU

9.24.34 EDGE_STYLE_B106 (0034h)

Table 162. EDGE_STYLE_B106 (address 0034h) EEPROM configuration bit description

Address (hex)	Function	Bit	Description
24	RFU	7	-
	Transmitter shaping configuration falling edge	6:4	If EDGE_TYPE is 1, 2 or 3: Time constant configuration of falling edge (depends on edge style) If EDGE_TYPE is 4,5,6: This number is the lookup table which shall be used of falling edge (0,1,2,3)
	RFU	3	-
	Transmitter shaping configuration rising edge	2:0	If EDGE_TYPE is 1, 2 or 3: Time constant configuration of rising edge (depends on edge style) If EDGE_TYPE is 4,5,6: This number is the lookup table which shall be used of rising edge (0,1,2,3)

9.24.35 EDGE_LENGTH_B106 (0035h)

Table 163. EDGE_LENGTH_B106 (address 0035h) EEPROM configuration bit description

Address (hex)	Function	Bit	Description
25	Transmitter shaping configuration	7	Scaling of edge transition by factor 2 of rising/falling edge (refers to both rising and falling edge at the same time) 0=disabled (1 transition state = one carrier cycle) 1=enabled (1 transition state = two carrier cycles)
		6:5	RFU
		4:0	Number of active transition states in rising and falling edge pattern (refers to both rising and falling edge at the same time)

9.24.36 RESIDUAL_AMPL_LEVEL_B212 (0036h)

Table 164. RESIDUAL_AMPL_LEVEL_B212 (address 0036h) EEPROM configuration bit description

Address (hex)	Function	Bit	Description
22	Transmitter shaping configuration	7:0	Residual amplitude level 00: 0 % carrier FF: 100 % carrier

9.24.37 EDGE_TYPE_B212 (0037h)

Table 165. EDGE_TYPE_B212 (address 0037h) EEPROM configuration bit description

Address (hex)	Function	Bit	Description
23	Transmitter shaping configuration	7:4	Definition of edge transition style of falling edge Defines style of edge transition: Firmware based shaping: 1: linear transition between two amplitude levels 2: two linear transitions between amplitude levels 3: three linear transitions between amplitude levels Others: RFU Lookup table based shaping: 4: lookup table-based transition, no automatic adaptation based on VDDPA 5: lookup table-based transition, automatic adaptation based on VDDPA including sCorrection 6: lookup table-based transition, automatic adaptation based on VDDPA but no sCorrection others: RFU
		3:0	Definition of edge transition style of rising edge Defines style of edge transition: Firmware based shaping: 1: linear transition between two amplitude levels 2: two linear transitions between amplitude levels 3: three linear transitions between amplitude levels Others: RFU Lookup table based shaping: 4: lookup table-based transition, no automatic adaptation based on VDDPA 5: lookup table-based transition, automatic adaptation based on VDDPA including sCorrection 6: lookup table-based transition, automatic adaptation based on VDDPA but no sCorrection others: RFU

9.24.38 EDGE_STYLE_B212 (0038h)

Table 166. EDGE_STYLE_B212 (address 0038h) EEPROM configuration bit description

Address (hex)	Function	Bit	Description
24	RFU	7	-

Table 166. EDGE_STYLE_B212 (address 0038h) EEPROM configuration bit description...continued

Address (hex)	Function	Bit	Description
	Transmitter shaping configuration falling edge	6:4	If EDGE_TYPE is 1, 2 or 3: Time constant configuration of falling edge (depends on edge style) If EDGE_TYPE is 4,5,6: This number is the lookup table which shall be used of falling edge (0,1,2,3)
	RFU	3	-
	Transmitter shaping configuration rising edge	2:0	If EDGE_TYPE is 1, 2 or 3: Time constant configuration of rising edge (depends on edge style) If EDGE_TYPE is 4,5,6: This number is the lookup table which shall be used of rising edge (0,1,2,3)

9.24.39 EDGE_LENGTH_B212 (0039h)

Table 167. EDGE_LENGTH_B212 (address 0039h) EEPROM configuration bit description

Address (hex)	Function	Bit	Description
25	Transmitter shaping configuration	7	Scaling of edge transition by factor 2 of rising/falling edge (refers to both rising and falling edge at the same time) 0=disabled (1 transition state = one carrier cycle) 1=enabled (1 transition state = two carrier cycles)
		6:5	RFU
		4:0	Number of active transition states in rising and falling edge pattern (refers to both rising and falling edge at the same time)

9.24.40 RESIDUAL_AMPL_LEVEL_B424 (003Ah)

Table 168. RESIDUAL_AMPL_LEVEL_B424 (address 003Ah) EEPROM configuration bit description

Address (hex)	Function	Bit	Description
22	Transmitter shaping configuration	7:0	Residual amplitude level 00: 0 % carrier FF: 100 % carrier

9.24.41 EDGE_TYPE_B424 (003Bh)

Table 169. EDGE_TYPE_B424 (address 003Bh) EEPROM configuration bit description

Address (hex)	Function	Bit	Description
23	Transmitter shaping configuration	7:4	Definition of edge transition style of falling edge Defines style of edge transition: Firmware based shaping: 1: linear transition between two amplitude levels 2: two linear transitions between amplitude levels 3: three linear transitions between amplitude levels Others: RFU Lookup table based shaping: 4: lookup table-based transition, no automatic adaptation based on VDDPA 5: lookup table-based transition, automatic adaptation based on VDDPA including sCorrection 6: lookup table-based transition, automatic adaptation based on VDDPA but no sCorrection others: RFU
		3:0	Definition of edge transition style of rising edge Defines style of edge transition: Firmware based shaping: 1: linear transition between two amplitude levels 2: two linear transitions between amplitude levels 3: three linear transitions between amplitude levels Others: RFU Lookup table based shaping: 4: lookup table-based transition, no automatic adaptation based on VDDPA 5: lookup table-based transition, automatic adaptation based on VDDPA including sCorrection 6: lookup table-based transition, automatic adaptation based on VDDPA but no sCorrection others: RFU

9.24.42 EDGE_STYLE_B424 (003Ch)

Table 170. EDGE_STYLE_B424 (address 003Ch) EEPROM configuration bit description

Address (hex)	Function	Bit	Description
24	RFU	7	-
	Transmitter shaping configuration falling edge	6:4	If EDGE_TYPE is 1,2 or 3: Time constant configuration of falling edge (depends on edge style) If EDGE_TYPE is 4,5,6: This number is the lookup table which shall be used of falling edge (0,1,2,3)
	RFU	3	-
	Transmitter shaping configuration rising edge	2:0	If EDGE_TYPE is 1,2 or 3: Time constant configuration of rising edge (depends on edge style) If EDGE_TYPE is 4,5,6: This number is the lookup table which shall be used of rising edge (0,1,2,3)

9.24.43 EDGE_LENGTH_B424 (003Dh)

Table 171. EDGE_LENGTH_B424 (address 003Dh) EEPROM configuration bit description

Address (hex)	Function	Bit	Description
25	Transmitter shaping configuration	7	Scaling of edge transition by factor 2 of rising/falling edge (refers to both rising and falling edge at the same time) 0=disabled (1 transition state = one carrier cycle) 1=enabled (1 transition state = two carrier cycles)
		6:5	RFU
		4:0	Number of active transition states in rising and falling edge pattern (refers to both rising and falling edge at the same time)

9.24.44 RESIDUAL_AMPL_LEVEL_B848 (003Eh)

Table 172. RESIDUAL_AMPL_LEVEL_B848 (address 003Eh) EEPROM configuration bit description

Address (hex)	Function	Bit	Description
22	Transmitter shaping configuration	7:0	Residual amplitude level 00: 0 % carrier FF: 100 % carrier

9.24.45 EDGE_TYPE_B848 (003Fh)

Table 173. EDGE_TYPE_B848 (address 003Fh) EEPROM configuration bit description

Address (hex)	Function	Bit	Description
23	Transmitter shaping configuration	7:4	Definition of edge transition style of falling edge Defines style of edge transition: Firmware based shaping: 1: linear transition between two amplitude levels 2: two linear transitions between amplitude levels 3: three linear transitions between amplitude levels Others: RFU Lookup table based shaping: 4: lookup table-based transition, no automatic adaptation based on VDDPA 5: lookup table-based transition, automatic adaptation based on VDDPA including sCorrection 6: lookup table-based transition, automatic adaptation based on VDDPA but no sCorrection others: RFU

Table 173. EDGE_TYPE_B848 (address 003Fh) EEPROM configuration bit description...continued

Address (hex)	Function	Bit	Description
		3:0	Definition of edge transition style of rising edge Defines style of edge transition: Firmware based shaping: 1: linear transition between two amplitude levels 2: two linear transitions between amplitude levels 3: three linear transitions between amplitude levels Others: RFU Lookup table based shaping: 4: lookup table-based transition, no automatic adaptation based on VDDPA 5: lookup table-based transition, automatic adaptation based on VDDPA including sCorrection 6: lookup table-based transition, automatic adaptation based on VDDPA but no sCorrection others: RFU

9.24.46 EDGE_STYLE_B848 (0040h)

Table 174. EDGE_STYLE_B848 (address 0040h) EEPROM configuration bit description

Address (hex)	Function	Bit	Description
24	RFU	7	-
	Transmitter shaping configuration falling edge	6:4	If EDGE_TYPE is 1, 2 or 3: Time constant configuration of falling edge (depends on edge style) If EDGE_TYPE is 4,5,6: This number is the lookup table which shall be used of falling edge (0,1,2,3)
	RFU	3	-
	Transmitter shaping configuration rising edge	2:0	If EDGE_TYPE is 1, 2 or 3: Time constant configuration of rising edge (depends on edge style) If EDGE_TYPE is 4,5,6: This number is the lookup table which shall be used of rising edge (0,1,2,3)

9.24.47 EDGE_LENGTH_B848 (0041h)

Table 175. EDGE_LENGTH_B848 (address 0041h) EEPROM configuration bit description

Address (hex)	Function	Bit	Description
25	Transmitter shaping configuration	7	Scaling of edge transition by factor 2 of rising/falling edge (refers to both rising and falling edge at the same time) 0=disabled (1 transition state = one carrier cycle) 1=enabled (1 transition state = two carrier cycles)
		6:5	RFU
		4:0	Number of active transition states in rising and falling edge pattern (refers to both rising and falling edge at the same time)

9.24.48 RESIDUAL_AMPL_LEVEL_F212 (0042h)

Table 176. RESIDUAL_AMPL_LEVEL_F212 (address 0042h) EEPROM configuration bit description

Address (hex)	Function	Bit	Description
22	Transmitter shaping configuration	7:0	Residual amplitude level 00: 0 % carrier FF: 100 % carrier

9.24.49 EDGE_TYPE_F212 (0043h)

Table 177. EDGE_TYPE_F212 (address 0043h) EEPROM configuration bit description

Address (hex)	Function	Bit	Description
23	Transmitter shaping configuration	7:4	Definition of edge transition style of falling edge Defines style of edge transition: Firmware based shaping: 1: linear transition between two amplitude levels 2: two linear transitions between amplitude levels 3: three linear transitions between amplitude levels Others: RFU Lookup table based shaping: 4: lookup table-based transition, no automatic adaptation based on VDDPA 5: lookup table-based transition, automatic adaptation based on VDDPA including sCorrection 6: lookup table-based transition, automatic adaptation based on VDDPA but no sCorrection others: RFU
		3:0	Definition of edge transition style of rising edge Defines style of edge transition: Firmware based shaping: 1: linear transition between two amplitude levels 2: two linear transitions between amplitude levels 3: three linear transitions between amplitude levels Others: RFU Lookup table based shaping: 4: lookup table-based transition, no automatic adaptation based on VDDPA 5: lookup table-based transition, automatic adaptation based on VDDPA including sCorrection 6: lookup table-based transition, automatic adaptation based on VDDPA but no sCorrection others: RFU

9.24.50 EDGE_STYLE_F212 (0044h)

Table 178. EDGE_STYLE_F212 (address 0044h) EEPROM configuration bit description

Address (hex)	Function	Bit	Description
24	RFU	7	-

Table 178. EDGE_STYLE_F212 (address 0044h) EEPROM configuration bit description...continued

Address (hex)	Function	Bit	Description
	Transmitter shaping configuration falling edge	6:4	If EDGE_TYPE is 1, 2 or 3: Time constant configuration of falling edge (depends on edge style) If EDGE_TYPE is 4,5,6: This number is the lookup table which shall be used of falling edge (0,1,2,3)
	RFU	3	-
	Transmitter shaping configuration rising edge	2:0	If EDGE_TYPE is 1, 2 or 3: Time constant configuration of rising edge (depends on edge style) If EDGE_TYPE is 4,5,6: This number is the lookup table which shall be used of rising edge (0,1,2,3)

9.24.51 EDGE_LENGTH_F212 (0045h)

Table 179. EDGE_LENGTH_F212 (address 0045h) EEPROM configuration bit description

Address (hex)	Function	Bit	Description
25	Transmitter shaping configuration	7	Scaling of edge transition by factor 2 of rising/falling edge (refers to both rising and falling edge at the same time) 0=disabled (1 transition state = one carrier cycle) 1=enabled (1 transition state = two carrier cycles)
		6:5	RFU
		4:0	Number of active transition states in rising and falling edge pattern (refers to both rising and falling edge at the same time)

9.24.52 RESIDUAL_AMPL_LEVEL_F424 (0046h)

Table 180. RESIDUAL_AMPL_LEVEL_F424 (address 0046h) EEPROM configuration bit description

Address (hex)	Function	Bit	Description
22	Transmitter shaping configuration	7:0	Residual amplitude level 00: 0 % carrier FF: 100 % carrier

9.24.53 EDGE_TYPE_F424 (0047h)

Table 181. EDGE_TYPE_F424 (address 0047h) EEPROM configuration bit description

Address (hex)	Function	Bit	Description
23	Transmitter shaping configuration	7:4	Definition of edge transition style of falling edge Defines style of edge transition: Firmware based shaping: 1: linear transition between two amplitude levels 2: two linear transitions between amplitude levels 3: three linear transitions between amplitude levels Others: RFU Lookup table based shaping: 4: lookup table-based transition, no automatic adaptation based on VDDPA 5: lookup table-based transition, automatic adaptation based on VDDPA including sCorrection 6: lookup table-based transition, automatic adaptation based on VDDPA but no sCorrection others: RFU
		3:0	Definition of edge transition style of rising edge Defines style of edge transition: Firmware based shaping: 1: linear transition between two amplitude levels 2: two linear transitions between amplitude levels 3: three linear transitions between amplitude levels Others: RFU Lookup table based shaping: 4: lookup table-based transition, no automatic adaptation based on VDDPA 5: lookup table-based transition, automatic adaptation based on VDDPA including sCorrection 6: lookup table-based transition, automatic adaptation based on VDDPA but no sCorrection others: RFU

9.24.54 EDGE_STYLE_F424 (0048h)

Table 182. EDGE_STYLE_F424 (address 0048h) EEPROM configuration bit description

Address (hex)	Function	Bit	Description
24	RFU	7	-
	Transmitter shaping configuration falling edge	6:4	If EDGE_TYPE is 1, 2 or 3: Time constant configuration of falling edge (depends on edge style) If EDGE_TYPE is 4,5,6: This number is the lookup table which shall be used of falling edge (0,1,2,3)
	RFU	3	-
	Transmitter shaping configuration rising edge	2:0	If EDGE_TYPE is 1, 2 or 3: Time constant configuration of rising edge (depends on edge style) If EDGE_TYPE is 4,5,6: This number is the lookup table which shall be used of rising edge (0,1,2,3)

9.24.55 EDGE_LENGTH_F424 (0049h)

Table 183. EDGE_LENGTH_F424 (address 0049h) EEPROM configuration bit description

Address (hex)	Function	Bit	Description
25	Transmitter shaping configuration	7	Scaling of edge transition by factor 2 of rising/falling edge (refers to both rising and falling edge at the same time) 0=disabled (1 transition state = one carrier cycle) 1=enabled (1 transition state = two carrier cycles)
		6:5	RFU
		4:0	Number of active transition states in rising and falling edge pattern (refers to both rising and falling edge at the same time)

9.24.56 RESIDUAL_AMPL_LEVEL_V100_26 (004Ah)

Table 184. RESIDUAL_AMPL_LEVEL_V100_26 (address 004Ah) EEPROM configuration bit description

Address (hex)	Function	Bit	Description
22	Transmitter shaping configuration	7:0	Residual amplitude level 00: 0 % carrier FF: 100 % carrier

9.24.57 EDGE_TYPE_V100_26 (004Bh)

Table 185. EDGE_TYPE_V100_26 (address 004Bh) EEPROM configuration bit description

Address (hex)	Function	Bit	Description
23	Transmitter shaping configuration	7:4	Definition of edge transition style of falling edge Defines style of edge transition: Firmware based shaping: 1: linear transition between two amplitude levels 2: two linear transitions between amplitude levels 3: three linear transitions between amplitude levels Others: RFU Lookup table based shaping: 4: lookup table-based transition, no automatic adaptation based on VDDPA 5: lookup table-based transition, automatic adaptation based on VDDPA including sCorrection 6: lookup table-based transition, automatic adaptation based on VDDPA but no sCorrection others: RFU

Table 185. EDGE_TYPE_V100_26 (address 004Bh) EEPROM configuration bit description...continued

Address (hex)	Function	Bit	Description
		3:0	Definition of edge transition style of rising edge Defines style of edge transition: Firmware based shaping: 1: linear transition between two amplitude levels 2: two linear transitions between amplitude levels 3: three linear transitions between amplitude levels Others: RFU Lookup table based shaping: 4: lookup table-based transition, no automatic adaptation based on VDDPA 5: lookup table-based transition, automatic adaptation based on VDDPA including sCorrection 6: lookup table-based transition, automatic adaptation based on VDDPA but no sCorrection others: RFU

9.24.58 EDGE_STYLE_V100_26 (004Ch)

Table 186. EDGE_STYLE_V100_26 (address 004Ch) EEPROM configuration bit description

Address (hex)	Function	Bit	Description
24	RFU	7	-
	Transmitter shaping configuration falling edge	6:4	If EDGE_TYPE is 1, 2 or 3: Time constant configuration of falling edge (depends on edge style) If EDGE_TYPE is 4,5,6: This number is the lookup table which shall be used of falling edge (0,1,2,3)
	RFU	3	-
	Transmitter shaping configuration rising edge	2:0	If EDGE_TYPE is 1, 2 or 3: Time constant configuration of rising edge (depends on edge style) If EDGE_TYPE is 4,5,6: This number is the lookup table which shall be used of rising edge (0,1,2,3)

9.24.59 EDGE_LENGTH_V100_26 (004Dh)

Table 187. EDGE_LENGTH_V100_26 (address 004Dh) EEPROM configuration bit description

Address (hex)	Function	Bit	Description
25	Transmitter shaping configuration	7	Scaling of edge transition by factor 2 of rising/falling edge (refers to both rising and falling edge at the same time) 0=disabled (1 transition state = one carrier cycle) 1=enabled (1 transition state = two carrier cycles)
		6:5	RFU
		4:0	Number of active transition states in rising and falling edge pattern (refers to both rising and falling edge at the same time)

9.24.60 RESIDUAL_AMPL_LEVEL_V100_53 (004Eh)

Table 188. RESIDUAL_AMPL_LEVEL_V100_53 (address 004Eh) EEPROM configuration bit description

Address (hex)	Function	Bit	Description
22	Transmitter shaping configuration	7:0	Residual amplitude level 00: 0 % carrier FF: 100 % carrier

9.24.61 EDGE_TYPE_V100_53 (004Fh)

Table 189. EDGE_TYPE_V100_53 (address 004Fh) EEPROM configuration bit description

Address (hex)	Function	Bit	Description
23	Transmitter shaping configuration	7:4	Definition of edge transition style of falling edge Defines style of edge transition: Firmware based shaping: 1: linear transition between two amplitude levels 2: two linear transitions between amplitude levels 3: three linear transitions between amplitude levels Others: RFU Lookup table based shaping: 4: lookup table-based transition, no automatic adaptation based on VDDPA 5: lookup table-based transition, automatic adaptation based on VDDPA including sCorrection 6: lookup table-based transition, automatic adaptation based on VDDPA but no sCorrection others: RFU
		3:0	Definition of edge transition style of rising edge Defines style of edge transition: Firmware based shaping: 1: linear transition between two amplitude levels 2: two linear transitions between amplitude levels 3: three linear transitions between amplitude levels Others: RFU Lookup table based shaping: 4: lookup table-based transition, no automatic adaptation based on VDDPA 5: lookup table-based transition, automatic adaptation based on VDDPA including sCorrection 6: lookup table-based transition, automatic adaptation based on VDDPA but no sCorrection others: RFU

9.24.62 EDGE_STYLE_V100_53 (0050h)

Table 190. EDGE_STYLE_A106 (address 0050h) EEPROM configuration bit description

Address (hex)	Function	Bit	Description
24	RFU	7	-

Table 190. EDGE_STYLE_A106 (address 0050h) EEPROM configuration bit description...continued

Address (hex)	Function	Bit	Description
	Transmitter shaping configuration falling edge	6:4	If EDGE_TYPE is 1, 2 or 3: Time constant configuration of falling edge (depends on edge style) If EDGE_TYPE is 4,5,6: This number is the lookup table which shall be used of falling edge (0,1,2,3)
	RFU	3	-
	Transmitter shaping configuration rising edge	2:0	If EDGE_TYPE is 1, 2 or 3: Time constant configuration of rising edge (depends on edge style) If EDGE_TYPE is 4,5,6: This number is the lookup table which shall be used of rising edge (0,1,2,3)

9.24.63 EDGE_LENGTH_V100_53 (0051h)

Table 191. EDGE_LENGTH_V100_53 (address 0051h) EEPROM configuration bit description

Address (hex)	Function	Bit	Description
25	Transmitter shaping configuration	7	Scaling of edge transition by factor 2 of rising/falling edge (refers to both rising and falling edge at the same time) 0=disabled (1 transition state = one carrier cycle) 1=enabled (1 transition state = two carrier cycles)
		6:5	RFU
		4:0	Number of active transition states in rising and falling edge pattern (refers to both rising and falling edge at the same time)

9.24.64 RESIDUAL_AMPL_LEVEL_V100_106 (0052h)

Table 192. RESIDUAL_AMPL_LEVEL_V100_106 (address 0052h) EEPROM configuration bit description

Address (hex)	Function	Bit	Description
22	Transmitter shaping configuration	7:0	Residual amplitude level 00: 0 % carrier FF: 100 % carrier

9.24.65 EDGE_TYPE_V100_106 (0053h)

Table 193. EDGE_TYPE_V100_106 (address 0053h) EEPROM configuration bit description

Address (hex)	Function	Bit	Description
23	Transmitter shaping configuration	7:4	Definition of edge transition style of falling edge Defines style of edge transition: Firmware based shaping: 1: linear transition between two amplitude levels 2: two linear transitions between amplitude levels 3: three linear transitions between amplitude levels Others: RFU Lookup table based shaping: 4: lookup table-based transition, no automatic adaptation based on VDDPA 5: lookup table-based transition, automatic adaptation based on VDDPA including sCorrection 6: lookup table-based transition, automatic adaptation based on VDDPA but no sCorrection others: RFU
		3:0	Definition of edge transition style of rising edge Defines style of edge transition: Firmware based shaping: 1: linear transition between two amplitude levels 2: two linear transitions between amplitude levels 3: three linear transitions between amplitude levels Others: RFU Lookup table based shaping: 4: lookup table-based transition, no automatic adaptation based on VDDPA 5: lookup table-based transition, automatic adaptation based on VDDPA including sCorrection 6: lookup table-based transition, automatic adaptation based on VDDPA but no sCorrection others: RFU

9.24.66 EDGE_STYLE_V100_106 (0054h)

Table 194. EDGE_STYLE_V100_106 (address 0054h) EEPROM configuration bit description

Address (hex)	Function	Bit	Description
24	RFU	7	-
	Transmitter shaping configuration falling edge	6:4	If EDGE_TYPE is 1, 2 or 3: Time constant configuration of falling edge (depends on edge style) If EDGE_TYPE is 4,5,6: This number is the lookup table which shall be used of falling edge (0,1,2,3)
	RFU	3	-
	Transmitter shaping configuration rising edge	2:0	If EDGE_TYPE is 1, 2 or 3: Time constant configuration of rising edge (depends on edge style) If EDGE_TYPE is 4,5,6: This number is the lookup table which shall be used of rising edge (0,1,2,3)

9.24.67 EDGE_LENGTH_V100_106 (0055h)

Table 195. EDGE_LENGTH_V100_106 (address 0055h) EEPROM configuration bit description

Address (hex)	Function	Bit	Description
25	Transmitter shaping configuration	7	Scaling of edge transition by factor 2 of rising/falling edge (refers to both rising and falling edge at the same time) 0=disabled (1 transition state = one carrier cycle) 1=enabled (1 transition state = two carrier cycles)
		6:5	RFU
		4:0	Number of active transition states in rising and falling edge pattern (refers to both rising and falling edge at the same time)

9.24.68 RESIDUAL_AMPL_LEVEL_100_212 (0056h)

Table 196. RESIDUAL_AMPL_LEVEL_100_212 (address 0056h) EEPROM configuration bit description

Address (hex)	Function	Bit	Description
22	Transmitter shaping configuration	7:0	Residual amplitude level 00: 0 % carrier FF: 100 % carrier

9.24.69 EDGE_TYPE_V100_212 (0057h)

Table 197. EDGE_TYPE_V100_212 (address 0057h) EEPROM configuration bit description

Address (hex)	Function	Bit	Description
23	Transmitter shaping configuration	7:4	Definition of edge transition style of falling edge Defines style of edge transition: Firmware based shaping: 1: linear transition between two amplitude levels 2: two linear transitions between amplitude levels 3: three linear transitions between amplitude levels Others: RFU Lookup table based shaping: 4: lookup table-based transition, no automatic adaptation based on VDDPA 5: lookup table-based transition, automatic adaptation based on VDDPA including sCorrection 6: lookup table-based transition, automatic adaptation based on VDDPA but no sCorrection others: RFU

Table 197. EDGE_TYPE_V100_212 (address 0057h) EEPROM configuration bit description...continued

Address (hex)	Function	Bit	Description
		3:0	Definition of edge transition style of rising edge Defines style of edge transition: Firmware based shaping: 1: linear transition between two amplitude levels 2: two linear transitions between amplitude levels 3: three linear transitions between amplitude levels Others: RFU Lookup table based shaping: 4: lookup table-based transition, no automatic adaptation based on VDDPA 5: lookup table-based transition, automatic adaptation based on VDDPA including sCorrection 6: lookup table-based transition, automatic adaptation based on VDDPA but no sCorrection others: RFU

9.24.70 EDGE_STYLE_V100_212 (0058h)

Table 198. EDGE_STYLE_V100_212 (address 0058h) EEPROM configuration bit description

Address (hex)	Function	Bit	Description
24	RFU	7	-
	Transmitter shaping configuration falling edge	6:4	If EDGE_TYPE is 1, 2 or 3: Time constant configuration of falling edge (depends on edge style) If EDGE_TYPE is 4,5,6: This number is the lookup table which shall be used of falling edge (0,1,2,3)
	RFU	3	-
	Transmitter shaping configuration rising edge	2:0	If EDGE_TYPE is 1, 2 or 3: Time constant configuration of rising edge (depends on edge style) If EDGE_TYPE is 4,5,6: This number is the lookup table which shall be used of rising edge (0,1,2,3)

9.24.71 EDGE_LENGTH_V100_212 (0059h)

Table 199. EDGE_LENGTH_V100_212 (address 0059h) EEPROM configuration bit description

Address (hex)	Function	Bit	Description
25	Transmitter shaping configuration	7	Scaling of edge transition by factor 2 of rising/falling edge (refers to both rising and falling edge at the same time) 0=disabled (1 transition state = one carrier cycle) 1=enabled (1 transition state = two carrier cycles)
		6:5	RFU
		4:0	Number of active transition states in rising and falling edge pattern (refers to both rising and falling edge at the same time)

9.24.72 RESIDUAL_AMPL_LEVEL_V10_26 (005Ah)

Table 200. RESIDUAL_AMPL_LEVEL_V10_26 (address 005Ah) EEPROM configuration bit description

Address (hex)	Function	Bit	Description
22	Transmitter shaping configuration	7:0	Residual amplitude level 00: 0 % carrier FF: 100 % carrier

9.24.73 EDGE_TYPE_V10_26 (005Bh)

Table 201. EDGE_TYPE_V10_26 (address 005Bh) EEPROM configuration bit description

Address (hex)	Function	Bit	Description
23	Transmitter shaping configuration	7:4	Definition of edge transition style of falling edge Defines style of edge transition: Firmware based shaping: 1: linear transition between two amplitude levels 2: two linear transitions between amplitude levels 3: three linear transitions between amplitude levels Others: RFU Lookup table based shaping: 4: lookup table-based transition, no automatic adaptation based on VDDPA 5: lookup table-based transition, automatic adaptation based on VDDPA including sCorrection 6: lookup table-based transition, automatic adaptation based on VDDPA but no sCorrection others: RFU
		3:0	Definition of edge transition style of rising edge Defines style of edge transition: Firmware based shaping: 1: linear transition between two amplitude levels 2: two linear transitions between amplitude levels 3: three linear transitions between amplitude levels Others: RFU Lookup table based shaping: 4: lookup table-based transition, no automatic adaptation based on VDDPA 5: lookup table-based transition, automatic adaptation based on VDDPA including sCorrection 6: lookup table-based transition, automatic adaptation based on VDDPA but no sCorrection others: RFU

9.24.74 EDGE_STYLE_V10_26 (005Ch)

Table 202. EDGE_STYLE_V10_26 (address 005Ch) EEPROM configuration bit description

Address (hex)	Function	Bit	Description
24	RFU	7	-

Table 202. EDGE_STYLE_V10_26 (address 005Ch) EEPROM configuration bit description...continued

Address (hex)	Function	Bit	Description
	Transmitter shaping configuration falling edge	6:4	If EDGE_TYPE is 1, 2 or 3: Time constant configuration of falling edge (depends on edge style) If EDGE_TYPE is 4,5,6: This number is the lookup table which shall be used of falling edge (0,1,2,3)
	RFU	3	-
	Transmitter shaping configuration rising edge	2:0	If EDGE_TYPE is 1, 2 or 3: Time constant configuration of rising edge (depends on edge style) If EDGE_TYPE is 4,5,6: This number is the lookup table which shall be used of rising edge (0,1,2,3)

9.24.75 EDGE_LENGTH_V10_26 (005Dh)

Table 203. EDGE_LENGTH_V10_26 (address 005Dh) EEPROM configuration bit description

Address (hex)	Function	Bit	Description
25	Transmitter shaping configuration	7	Scaling of edge transition by factor 2 of rising/falling edge (refers to both rising and falling edge at the same time) 0=disabled (1 transition state = one carrier cycle) 1=enabled (1 transition state = two carrier cycles)
		6:5	RFU
		4:0	Number of active transition states in rising and falling edge pattern (refers to both rising and falling edge at the same time)

9.24.76 RESIDUAL_AMPL_LEVEL_V10_53 (005Eh)

Table 204. RESIDUAL_AMPL_LEVEL_V10_53 (address 005Eh) EEPROM configuration bit description

Address (hex)	Function	Bit	Description
22	Transmitter shaping configuration	7:0	Residual amplitude level 00: 0 % carrier FF: 100 % carrier

9.24.77 EDGE_TYPE_V10_53 (005Fh)

Table 205. EDGE_TYPE_V10_53 (address 005Fh) EEPROM configuration bit description

Address (hex)	Function	Bit	Description
23	Transmitter shaping configuration	7:4	Definition of edge transition style of falling edge Defines style of edge transition: Firmware based shaping: 1: linear transition between two amplitude levels 2: two linear transitions between amplitude levels 3: three linear transitions between amplitude levels Others: RFU Lookup table based shaping: 4: lookup table-based transition, no automatic adaptation based on VDDPA 5: lookup table-based transition, automatic adaptation based on VDDPA including sCorrection 6: lookup table-based transition, automatic adaptation based on VDDPA but no sCorrection others: RFU
		3:0	Definition of edge transition style of rising edge Defines style of edge transition: Firmware based shaping: 1: linear transition between two amplitude levels 2: two linear transitions between amplitude levels 3: three linear transitions between amplitude levels Others: RFU Lookup table based shaping: 4: lookup table-based transition, no automatic adaptation based on VDDPA 5: lookup table-based transition, automatic adaptation based on VDDPA including sCorrection 6: lookup table-based transition, automatic adaptation based on VDDPA but no sCorrection others: RFU

9.24.78 EDGE_STYLE_V10_53 (0060h)

Table 206. EDGE_STYLE_V10_53 (address 0060h) EEPROM configuration bit description

Address (hex)	Function	Bit	Description
24	RFU	7	-
	Transmitter shaping configuration falling edge	6:4	If EDGE_TYPE is 1, 2 or 3: Time constant configuration of falling edge (depends on edge style) If EDGE_TYPE is 4,5,6: This number is the lookup table which shall be used of falling edge (0,1,2,3)
	RFU	3	-
	Transmitter shaping configuration rising edge	2:0	If EDGE_TYPE is 1, 2 or 3: Time constant configuration of rising edge (depends on edge style) If EDGE_TYPE is 4,5,6: This number is the lookup table which shall be used of rising edge (0,1,2,3)

9.24.79 EDGE_LENGTH_V10_53 (0061h)

Table 207. EDGE_LENGTH_V10_53 (address 0061h) EEPROM configuration bit description

Address (hex)	Function	Bit	Description
25	Transmitter shaping configuration	7	Scaling of edge transition by factor 2 of rising/falling edge (refers to both rising and falling edge at the same time) 0=disabled (1 transition state = one carrier cycle) 1=enabled (1 transition state = two carrier cycles)
		6:5	RFU
		4:0	Number of active transition states in rising and falling edge pattern (refers to both rising and falling edge at the same time)

9.24.80 RESIDUAL_AMPL_LEVEL_V10_106 (0062h)

Table 208. RESIDUAL_AMPL_LEVEL_V10_106 (address 0062h) EEPROM configuration bit description

Address (hex)	Function	Bit	Description
22	Transmitter shaping configuration	7:0	Residual amplitude level 00: 0 % carrier FF: 100 % carrier

9.24.81 EDGE_TYPE_V10_106 (0063h)

Table 209. EDGE_TYPE_V10_106 (address 0063h) EEPROM configuration bit description

Address (hex)	Function	Bit	Description
23	Transmitter shaping configuration	7:4	Definition of edge transition style of falling edge Defines style of edge transition: Firmware based shaping: 1: linear transition between two amplitude levels 2: two linear transitions between amplitude levels 3: three linear transitions between amplitude levels Others: RFU Lookup table based shaping: 4: lookup table-based transition, no automatic adaptation based on VDDPA 5: lookup table-based transition, automatic adaptation based on VDDPA including sCorrection 6: lookup table-based transition, automatic adaptation based on VDDPA but no sCorrection others: RFU

Table 209. EDGE_TYPE_V10_106 (address 0063h) EEPROM configuration bit description...continued

Address (hex)	Function	Bit	Description
		3:0	Definition of edge transition style of rising edge Defines style of edge transition: Firmware based shaping: 1: linear transition between two amplitude levels 2: two linear transitions between amplitude levels 3: three linear transitions between amplitude levels Others: RFU Lookup table based shaping: 4: lookup table-based transition, no automatic adaptation based on VDDPA 5: lookup table-based transition, automatic adaptation based on VDDPA including sCorrection 6: lookup table-based transition, automatic adaptation based on VDDPA but no sCorrection others: RFU

9.24.82 EDGE_STYLE_V10_106 (0064h)

Table 210. EDGE_STYLE_V100_212 (address 0064h) EEPROM configuration bit description

Address (hex)	Function	Bit	Description
24	RFU	7	-
	Transmitter shaping configuration falling edge	6:4	If EDGE_TYPE is 1, 2 or 3: Time constant configuration of falling edge (depends on edge style) If EDGE_TYPE is 4,5,6: This number is the lookup table which shall be used of falling edge (0,1,2,3)
	RFU	3	-
	Transmitter shaping configuration rising edge	2:0	If EDGE_TYPE is 1, 2 or 3: Time constant configuration of rising edge (depends on edge style) If EDGE_TYPE is 4,5,6: This number is the lookup table which shall be used of rising edge (0,1,2,3)

9.24.83 EDGE_LENGTH_V10_106 (0065h)

Table 211. EDGE_LENGTH_V10_106 (address 0065h) EEPROM configuration bit description

Address (hex)	Function	Bit	Description
25	Transmitter shaping configuration	7	Scaling of edge transition by factor 2 of rising/falling edge (refers to both rising and falling edge at the same time) 0=disabled (1 transition state = one carrier cycle) 1=enabled (1 transition state = two carrier cycles)
		6:5	RFU
		4:0	Number of active transition states in rising and falling edge pattern (refers to both rising and falling edge at the same time)

9.24.84 RESIDUAL_AMPL_LEVEL_V10_212 (0066h)

Table 212. RESIDUAL_AMPL_LEVEL_V10_212 (address 0066h) EEPROM configuration bit description

Address (hex)	Function	Bit	Description
22	Transmitter shaping configuration	7:0	Residual amplitude level 00: 0 % carrier FF: 100 % carrier

9.24.85 EDGE_TYPE_V10_212 (0067h)

Table 213. EDGE_TYPE_V10_212 (address 0067h) EEPROM configuration bit description

Address (hex)	Function	Bit	Description
23	Transmitter shaping configuration	7:4	Definition of edge transition style of falling edge Defines style of edge transition: Firmware based shaping: 1: linear transition between two amplitude levels 2: two linear transitions between amplitude levels 3: three linear transitions between amplitude levels Others: RFU Lookup table based shaping: 4: lookup table-based transition, no automatic adaptation based on VDDPA 5: lookup table-based transition, automatic adaptation based on VDDPA including sCorrection 6: lookup table-based transition, automatic adaptation based on VDDPA but no sCorrection others: RFU
		3:0	Definition of edge transition style of rising edge Defines style of edge transition: Firmware based shaping: 1: linear transition between two amplitude levels 2: two linear transitions between amplitude levels 3: three linear transitions between amplitude levels Others: RFU Lookup table based shaping: 4: lookup table-based transition, no automatic adaptation based on VDDPA 5: lookup table-based transition, automatic adaptation based on VDDPA including sCorrection 6: lookup table-based transition, automatic adaptation based on VDDPA but no sCorrection others: RFU

9.24.86 EDGE_STYLE_V10_212 (0068h)

Table 214. EDGE_STYLE_V10_212 (address 0068h) EEPROM configuration bit description

Address (hex)	Function	Bit	Description
24	RFU	7	-

Table 214. EDGE_STYLE_V10_212 (address 0068h) EEPROM configuration bit description...continued

Address (hex)	Function	Bit	Description
	Transmitter shaping configuration falling edge	6:4	If EDGE_TYPE is 1, 2 or 3: Time constant configuration of falling edge (depends on edge style) If EDGE_TYPE is 4,5,6: This number is the lookup table which shall be used of falling edge (0,1,2,3)
	RFU	3	-
	Transmitter shaping configuration rising edge	2:0	If EDGE_TYPE is 1, 2 or 3: Time constant configuration of rising edge (depends on edge style) If EDGE_TYPE is 4,5,6: This number is the lookup table which shall be used of rising edge (0,1,2,3)

9.24.87 EDGE_LENGTH_V10_212 (0069h)

Table 215. EDGE_LENGTH_V100_212 (address 0069h) EEPROM configuration bit description

Address (hex)	Function	Bit	Description
25	Transmitter shaping configuration	7	Scaling of edge transition by factor 2 of rising/falling edge (refers to both rising and falling edge at the same time) 0=disabled (1 transition state = one carrier cycle) 1=enabled (1 transition state = two carrier cycles)
		6:5	RFU
		4:0	Number of active transition states in rising and falling edge pattern (refers to both rising and falling edge at the same time)

9.24.88 RESIDUAL_AMPL_LEVEL_180003m3_tari18p88 (006Ah)

Table 216. RESIDUAL_AMPL_LEVEL_180003m3_tari18p88 (address 006Ah) EEPROM configuration bit description

Address (hex)	Function	Bit	Description
22	Transmitter shaping configuration	7:0	Residual amplitude level 00: 0 % carrier FF: 100 % carrier

9.24.89 EDGE_TYPE_180003m3_tari18p88 (006Bh)

Table 217. EDGE_TYPE_180003m3_tari18p88 (address 006Bh) EEPROM configuration bit description

Address (hex)	Function	Bit	Description
23	Transmitter shaping configuration	7:4	Definition of edge transition style of falling edge Defines style of edge transition: Firmware based shaping: 1: linear transition between two amplitude levels 2: two linear transitions between amplitude levels 3: three linear transitions between amplitude levels Others: RFU Lookup table based shaping: 4: lookup table-based transition, no automatic adaptation based on VDDPA 5: lookup table-based transition, automatic adaptation based on VDDPA including sCorrection 6: lookup table-based transition, automatic adaptation based on VDDPA but no sCorrection others: RFU
		3:0	Definition of edge transition style of rising edge Defines style of edge transition: Firmware based shaping: 1: linear transition between two amplitude levels 2: two linear transitions between amplitude levels 3: three linear transitions between amplitude levels Others: RFU Lookup table based shaping: 4: lookup table-based transition, no automatic adaptation based on VDDPA 5: lookup table-based transition, automatic adaptation based on VDDPA including sCorrection 6: lookup table-based transition, automatic adaptation based on VDDPA but no sCorrection others: RFU

9.24.90 EDGE_STYLE_180003m3_tari18p88 (006Ch)

Table 218. EDGE_STYLE_180003m3_tari18p88 (address 006Ch) EEPROM configuration bit description

Address (hex)	Function	Bit	Description
24	RFU	7	-
	Transmitter shaping configuration falling edge	6:4	If EDGE_TYPE is 1, 2 or 3: Time constant configuration of falling edge (depends on edge style) If EDGE_TYPE is 4,5,6: This number is the lookup table which shall be used of falling edge (0,1,2,3)
	RFU	3	-
	Transmitter shaping configuration rising edge	2:0	If EDGE_TYPE is 1, 2 or 3: Time constant configuration of rising edge (depends on edge style) If EDGE_TYPE is 4,5,6: This number is the lookup table which shall be used of rising edge (0,1,2,3)

9.24.91 EDGE_LENGTH_180003m3_tari18p88 (006Dh)

Table 219. EDGE_LENGTH_180003m3_tari18p88 (address 006Dh) EEPROM configuration bit description

Address (hex)	Function	Bit	Description
25	Transmitter shaping configuration	7	Scaling of edge transition by factor 2 of rising/falling edge (refers to both rising and falling edge at the same time) 0=disabled (1 transition state = one carrier cycle) 1=enabled (1 transition state = two carrier cycles)
		6:5	RFU
		4:0	Number of active transition states in rising and falling edge pattern (refers to both rising and falling edge at the same time)

9.24.92 RESIDUAL_AMPL_LEVEL_180003m3_tari9p44 (006Eh)

Table 220. RESIDUAL_AMPL_LEVEL_180003m3_tari9p44 (address 006Eh) EEPROM configuration bit description

Address (hex)	Function	Bit	Description
22	Transmitter shaping configuration	7:0	Residual amplitude level 00: 0 % carrier FF: 100 % carrier

9.24.93 EDGE_TYPE_180003m3_tari9p44 (006Fh)

Table 221. EDGE_TYPE_180003m3_tari9p44 (address 006Fh) EEPROM configuration bit description

Address (hex)	Function	Bit	Description
23	Transmitter shaping configuration	7:4	Definition of edge transition style of falling edge Defines style of edge transition: Firmware based shaping: 1: linear transition between two amplitude levels 2: two linear transitions between amplitude levels 3: three linear transitions between amplitude levels Others: RFU Lookup table based shaping: 4: lookup table-based transition, no automatic adaptation based on VDDPA 5: lookup table-based transition, automatic adaptation based on VDDPA including sCorrection 6: lookup table-based transition, automatic adaptation based on VDDPA but no sCorrection others: RFU

Table 221. EDGE_TYPE_180003m3_tari9p44 (address 006Fh) EEPROM configuration bit description...continued

Address (hex)	Function	Bit	Description
		3:0	Definition of edge transition style of rising edge Defines style of edge transition: Firmware based shaping: 1: linear transition between two amplitude levels 2: two linear transitions between amplitude levels 3: three linear transitions between amplitude levels Others: RFU Lookup table based shaping: 4: lookup table-based transition, no automatic adaptation based on VDDPA 5: lookup table-based transition, automatic adaptation based on VDDPA including sCorrection 6: lookup table-based transition, automatic adaptation based on VDDPA but no sCorrection others: RFU

9.24.94 EDGE_STYLE_180003m3_tari9p44 (0070h)

Table 222. EDGE_STYLE_180003m3_tari9p44 (address 0070h) EEPROM configuration bit description

Address (hex)	Function	Bit	Description
24	RFU	7	-
	Transmitter shaping configuration falling edge	6:4	If EDGE_TYPE is 1, 2 or 3: Time constant configuration of falling edge (depends on edge style) If EDGE_TYPE is 4,5,6: This number is the lookup table which shall be used of falling edge (0,1,2,3)
	RFU	3	-
	Transmitter shaping configuration rising edge	2:0	If EDGE_TYPE is 1, 2 or 3: Time constant configuration of rising edge (depends on edge style) If EDGE_TYPE is 4,5,6: This number is the lookup table which shall be used of rising edge (0,1,2,3)

9.24.95 EDGE_LENGTH_180003m3_tari9p44 (0071h)

Table 223. EDGE_LENGTH_180003m3_tari9p44 (address 0071h) EEPROM configuration bit description

Address (hex)	Function	Bit	Description
25	Transmitter shaping configuration	7	Scaling of edge transition by factor 2 of rising/falling edge (refers to both rising and falling edge at the same time) 0=disabled (1 transition state = one carrier cycle) 1=enabled (1 transition state = two carrier cycles)
		6:5	RFU
		4:0	Number of active transition states in rising and falling edge pattern (refers to both rising and falling edge at the same time)

9.24.96 RESIDUAL_AMPL_LEVEL_B_PRIME_106 (0072h)

Table 224. RESIDUAL_AMPL_LEVEL_180003m3_tari18p88 (address 0072h) EEPROM configuration bit description

Address (hex)	Function	Bit	Description
22	Transmitter shaping configuration	7:0	Residual amplitude level 00: 0 % carrier FF: 100 % carrier

9.24.97 EDGE_TYPE_B_PRIME_106 (0073h)

Table 225. EDGE_TYPE_B_PRIME_106 (address 0073h) EEPROM configuration bit description

Address (hex)	Function	Bit	Description
23	Transmitter shaping configuration	7:4	Definition of edge transition style of falling edge Defines style of edge transition: Firmware based shaping: 1: linear transition between two amplitude levels 2: two linear transitions between amplitude levels 3: three linear transitions between amplitude levels Others: RFU Lookup table based shaping: 4: lookup table-based transition, no automatic adaptation based on VDDPA 5: lookup table-based transition, automatic adaptation based on VDDPA including sCorrection 6: lookup table-based transition, automatic adaptation based on VDDPA but no sCorrection others: RFU
		3:0	Definition of edge transition style of rising edge Defines style of edge transition: Firmware based shaping: 1: linear transition between two amplitude levels 2: two linear transitions between amplitude levels 3: three linear transitions between amplitude levels Others: RFU Lookup table based shaping: 4: lookup table-based transition, no automatic adaptation based on VDDPA 5: lookup table-based transition, automatic adaptation based on VDDPA including sCorrection 6: lookup table-based transition, automatic adaptation based on VDDPA but no sCorrection others: RFU

9.24.98 EDGE_STYLE_B_PRIME_106 (0074h)

Table 226. EDGE_STYLE_B_PRIME_106 (address 0074h) EEPROM configuration bit description

Address (hex)	Function	Bit	Description
24	RFU	7	-

Table 226. EDGE_STYLE_B_PRIME_106 (address 0074h) EEPROM configuration bit description...continued

Address (hex)	Function	Bit	Description
	Transmitter shaping configuration falling edge	6:4	If EDGE_TYPE is 1, 2 or 3: Time constant configuration of falling edge (depends on edge style) If EDGE_TYPE is 4,5,6: This number is the lookup table which shall be used of falling edge (0,1,2,3)
	RFU	3	-
	Transmitter shaping configuration rising edge	2:0	If EDGE_TYPE is 1, 2 or 3: Time constant configuration of rising edge (depends on edge style) If EDGE_TYPE is 4,5,6: This number is the lookup table which shall be used of rising edge (0,1,2,3)

9.24.99 EDGE_LENGTH_B_PRIME_106 (0075h)

Table 227. EDGE_LENGTH_B_PRIME_106 (address 0075h) EEPROM configuration bit description

Address (hex)	Function	Bit	Description
25	Transmitter shaping configuration	7	Scaling of edge transition by factor 2 of rising/falling edge (refers to both rising and falling edge at the same time) 0=disabled (1 transition state = one carrier cycle) 1=enabled (1 transition state = two carrier cycles)
		6:5	RFU
		4:0	Number of active transition states in rising and falling edge pattern (refers to both rising and falling edge at the same time)

9.24.100 DPC_CONFIG (0076h)

Table 228. DPC_CONFIG (address 0076h) EEPROM configuration bit description

Address (hex)	Function	Bit	Description
76	DPC Configuration	7:3	RFU
		2	DPC in Active Target Mode: 0: disabled, 1: enabled
		1	DPC in Active Initiator Mode: 0: disabled, 1: enabled
		0	DPC in Reader/ Passive Initiator Mode: 0: disabled, 1: enabled

9.24.101 DPC_TARGET_CURRENT (077h)

Table 229. DPC_TARGET_CURRENT (address 077h) EEPROM configuration bit description

Address (hex)	Function	Bit	Description
77	DPC Configuration	15:0	VDDPA target current in mA. The target current +/- hysteresis defines the limiting maximum current for the DPC. This configuration shall not exceed 350 mA - hysteresis.

Note: The resulting current that is driven by the transmitter can be further reduced based on the current reduction lookup table entries.

9.24.102 DPC_HYSTERESIS_LOADING (079h)

The hysteresis (DPC_HYSTERESIS_LOADING, DPC_HYSTERESIS_UNLOADING) together with the target current (DPC_TARGET_CURRENT) defines the current limit, at which the DPC automatically decreases or increases the VDDPA.

The VDDPA is automatically reduced, as soon as the current exceeds the DPC_TARGET_CURRENT + DPC_HYSTERESIS_LOADING, and the VDDPA is automatically increased again, as soon as the current is below DPC_TARGET_CURRENT – DPC_HYSTERESIS_UNLOADING.

Table 230. DPC_HYSTERESIS_LOADING (address 079h) EEPROM configuration bit description

Address (hex)	Function	Bit	Description
79	DPC Configuration	7:0	Absolute difference of measured transmitter current (target current incl. current reduction) in mA that triggers a DPC update event during loading.

Note: If the hysteresis is configured too small, it might cause an oscillation of the transmitted field.

Note: In most application, the default values work well and do not need to be modified.

9.24.103 DPC_HYSTERESIS_UNLOADING (07Ch)

The hysteresis (DPC_HYSTERESIS_LOADING, DPC_HYSTERESIS_UNLOADING) together with the target current (DPC_TARGET_CURRENT) defines the current limit, at which the DPC automatically decreases or increases the VDDPA.

The VDDPA is automatically reduced, as soon as the current exceeds the DPC_TARGET_CURRENT + DPC_HYSTERESIS_LOADING, and the VDDPA is automatically increased again, as soon as the current is below DPC_TARGET_CURRENT – DPC_HYSTERESIS_UNLOADING.

Table 231. DPC_HYSTERESIS_UNLOADING (address 07Ch) EEPROM configuration bit description

Address (hex)	Function	Bit	Description
7C	DPC Configuration	7:0	Absolute difference of measured transmitter current (target current incl. current reduction) in mA that triggers a DPC update event during unloading.

Note: If the hysteresis is configured too small, it might cause an oscillation of the transmitted field.

Note: In most application, the default values work well and do not need to be modified.

9.24.104 DPC_TXLDOVDDPALow (007Dh)

Table 232. DPC_TXLDOVDDPALow (address 007Dh) EEPROM configuration register bit description

Address (hex)	Function	Bit	Description
7D	DPC Configuration	7:0	VDDPA Low Limit for RDON

9.24.105 DPC_TXGSN (007Eh)

Table 233. DPC_TXGSN (address 007Eh) EEPROM configuration register bit description

Address (hex)	Function	Bit	Description
7E	DPC Configuration	7:0	for tx1_gsn < 20: resistance = 10 Ohm / (tx1_gsn + 1) for tx1_gsn >= 20: resistance = 0.5 Ohm

9.24.106 DPC_RDON_Control (007Fh)

Table 234. DPC_RDON_Control (address 007Fh) EEPROM configuration register bit description

Address (hex)	Function	Bit	Description
7F	DPC Configuration	7:0	00: Disabled 01: RdON Control 02-FF: RFU

9.24.107 DPC_InitialRDON_RFOn (0080h)

Table 235. DPC_InitialRDON_RFOn (address 0080h) EEPROM configuration register bit description

Address (hex)	Function	Bit	Description
80	DPC Configuration	7:0	Initial GSP TX1/TX2 value during FieldON

9.24.108 DPC_GUARD_TIME (087h)

Table 236. DPC_GUARD_TIME (address 087h) EEPROM configuration bit description

Address (hex)	Function	Bit	Description
87	DPC guard time configuration	7:0	Guard time before TX and after RX. 1unit = 1us. The DPC regulation is done once before TX and once after RX. The guard time parameter is the time between DPC regulation completion and TX start. The guard time parameter is the time between RX stop and DPC regulation start. The guard time is always enabled for TX

Note: Recommendation is not to modify the default value.

9.24.109 DPC_ENABLE_DURING_FDT (088h)

Table 237. DPC_ENABLE_DURING_FDT (address 088h) EEPROM configuration bit description

Address (hex)	Function	Bit	Description
88	DPC Configuration	7	DPC regulation enable during FDT 0: DPC disabled during FDT (debug purpose only) 1: DPC enabled during FDT (recommendation)

9.24.110 DPC_GUARD_TIME_AFTER_RX (089h)

Table 238. DPC_GUARD_TIME_AFTER_RX (address 089h) EEPROM configuration bit description

Address (hex)	Function	Bit	Description
89	RFU	7:1	-
89	DPC Configuration	0	Enable DPC guard time after RX 0: disable (debug purposes) 1: enable (recommended) The guard time can be configured in register DPC_GUARD_TIME

Note: The guard time is always enabled for TX and cannot be disabled.

9.24.111 DPC_LOOKUP_TABLE (008Bh-0133h)

Table 239. DPC_LOOKUP_TABLE (008Bh-0133h) EEPROM configuration bit description

Address (hex)	Function	Bit	Description
	ENTRY 0	31:0	This is the entry for 1.5 V
08B	Target current reduction	31:23	ENTRY 0 -LSB - byte 0 Voltage step between DPC entries = 100 mV. Voltage offset start = 1.5 V bEntry_00 = 1V5 ... bEntry_42 = 5V7 Bits[7:0] = Target current reduction in mA (unsigned)
08C	AWC amp mod change	23:16	ENTRY 0 - byte 1 Bits[7:0] = Relative change of modulated amplitude level (signed)
08D	AWC edge time constant for ASK100	15:8	ENTRY 0 - byte 2 Bits[3:0] = ASK100, Relative change of falling edge time constant (signed) Bits[7:4] = ASK100, Relative change of rising edge time constant (signed)
08E	AWC falling edge time constant for ASK10	7:0	ENTRY 0 -MSB - byte 4 Bits[3:0] = ASK10, Relative change of falling edge time constant (signed) Bits[7:4] = ASK10, Relative change of rising edge time constant (signed)
08F	ENTRY 1	31:0	This is the entry for 1.6 V
....		
093	ENTRY 2	31:0	This is the entry for 1.7 V
.....		
....			This is the entry for 5.6 V
0133	ENTRY 42	31:0	This is the entry for 5.7 V

9.24.112 ARC_CONFIG (0137h)

Table 240. ARC_CONFIG (address 0137h) EEPROM configuration bit description

Address (hex)	Function	Bit	Description
137	ARC Setting configuration	7	ARC algorithm enable 0: Disable 1: Enable
		6:3	RFU
		2:0	Number of entries in ARC table. (value between 0 to 4) 0: one entry 1: two entries 2: three entries 3: four entries 4: five entries

9.24.113 ARC_VDDPA (0139h)

Table 241. ARC_VDDPA (0139Eh) EEPROM configuration bit description

Address (hex)	Function	Bit	Description
13D	VDDPA_4	7:0	Byte[4] = VDDPA_range_index 4: if VDDPA voltage between VDDPA_3 to ARC_VDDPA_4
13C	VDDPA_3	7:0	Byte[3] = VDDPA_range_index 3: if VDDPA voltage between VDDPA_2 to ARC_VDDPA_3 - 0.1
13B	VDDPA_2	7:0	Byte[2] = VDDPA_range_index 2: if VDDPA voltage between VDDPA_1 to ARC_VDDPA_2 - 0.1
13A	VDDPA_1	7:0	Byte[1] = VDDPA_range_index 1: if VDDPA voltage between VDDPA_0 to (ARC_VDDPA_1 - 0.1)
139	VDDPA_0	7:0	Byte[0] = VDDPA_range_index 0: if VDDPA voltage between 1.5 to (VDDPA_0 - 0.1)

Note: VDDPA setting for Bytes 0...4:

0x00: 1V50

0x01: 1V60

0x02: 1V70

0x03: 1V80

0x04: 1V90

0x05: 2V00

0x06: 2V10

0x07: 2V20

0x08: 2V30

0x09: 2V40

0x0A: 2V50

0x0B: 2V60

0x0C: 2V70

0x0D: 2V80

0x0E: 2V90

0x0F: 3V00

0x10: 3V10

0x11: 3V20

0x12: 3V30

0x13: 3V40

0x14: 3V50

0x15: 3V60

0x16: 3V70

0x17: 3V80

0x18: 3V90

0x19: 4V00

0x1A: 4V10

0x1B: 4V20

0x1C: 4V30

0x1D: 4V40

0x1E: 4V50

0x1F: 4V60

0x20: 4V70

0x21: 4V80

0x22: 4V90

0x23: 5V00

0x24: 5V10

0x25: 5V20

0x26: 5V30

0x27: 5V40

0x28: 5V50

0x29: 5V60

0x2A: 5V70

9.24.114 ARC_RM_A106 (013Eh)

This is the setting for type A-106.

Table 242. ARC_RM_A106 (address 013Eh) EEPROM configuration bit description

Address (hex)	Function	Bit	Description
146	RM_RX_ARC_4	15:0	<p>Bit[15]</p> <p>This setting is only taken into account if bit 14 of address 13E is set.</p> <p>0: ARC settings always apply, bits 0..9 from the table ARC_RM_A106 are used</p> <p>1: ARC settings during FDT, bits 0..9 of table ARC_RM_A106_FDT are used, else bits 0..9 of table ARC_RM_A106 are used</p> <p>Bits[14:10] = RFU</p> <p>Bit [9] = Enable the IIR filter.</p> <p>Bits[8:7] = MF_GAIN (this value will be applied to the SIGPR_RM_TECH register, applies as soon as the ARC is enabled)</p> <p>Bits[6:0] = DPC_SIGNAL_DETECT_TH_OVR_VAL (this value will be applied to the DGRM_RSSI register, applies as soon as the ARC is enabled)</p>
144	RM_RX_ARC_3	15:0	<p>Bit[15]</p> <p>This setting is only taken into account if bit 14 of address 13E is set.</p> <p>0: ARC settings always apply, bits 0..9 from the table ARC_RM_A106 are used</p> <p>1: ARC settings during FDT, bits 0..9 of table ARC_RM_A106_FDT are used, else bits 0..9 of table ARC_RM_A106 are used</p> <p>Bits[14:10] = RFU</p> <p>Bit [9] = Enable the IIR filter.</p> <p>Bits[8:7] = MF_GAIN (this value will be applied to the SIGPR_RM_TECH register, applies as soon as the ARC is enabled)</p> <p>Bits[6:0] = DPC_SIGNAL_DETECT_TH_OVR_VAL (this value will be applied to the DGRM_RSSI register, applies as soon as the ARC is enabled)</p>
142	RM_RX_ARC_2	15:0	<p>Bit[15]</p> <p>This setting is only taken into account if bit 14 of address 13E is set.</p> <p>0: ARC settings always apply, bits 0..9 from the table ARC_RM_106 are used</p> <p>1: ARC settings during FDT, bits 0..9 of table ARC_RM_A106_FDT are used, else bits 0..9 of table ARC_RM_A106 are used</p> <p>Bits[14:10] = RFU</p> <p>Bit [9] = Enable the IIR filter.</p> <p>Bits[8:7] = MF_GAIN (this value will be applied to the SIGPR_RM_TECH register, applies as soon as the ARC is enabled)</p> <p>Bits[6:0] = DPC_SIGNAL_DETECT_TH_OVR_VAL (this value will be applied to the DGRM_RSSI register, applies as soon as the ARC is enabled)</p>
140	RM_RX_ARC_1	15:0	<p>Bit[15]</p> <p>This setting is only taken into account if bit 14 of address 13E is set.</p> <p>0: ARC settings always apply, bits 0..9 from the table ARC_RM_A106 are used</p> <p>1: ARC settings during FDT, bits 0..9 of table ARC_RM_A106_FDT are used, else bits 0..9 of table ARC_RM_A106 are used</p> <p>Bits[14:10] = RFU</p> <p>Bit [9] = Enable the IIR filter.</p> <p>Bits[8:7] = MF_GAIN (this value will be applied to the SIGPR_RM_TECH register, applies as soon as the ARC is enabled)</p> <p>Bits[6:0] = DPC_SIGNAL_DETECT_TH_OVR_VAL (this value will be applied to the DGRM_RSSI register, applies as soon as the ARC is enabled)</p>

Table 242. ARC_RM_A106 (address 013Eh) EEPROM configuration bit description...continued

Address (hex)	Function	Bit	Description
13E	RM_RX_ARC_0	15:0	Bit[15] This setting is only taken into account if bit 14 of address 13E is set. 0: ARC settings always apply, bits 0..9 from the table ARC_RM_A106 are used 1: ARC settings during FDT, bits 0..9 of table ARC_RM_A106_FDT are used, else bits 0..9 of table ARC_RM_A106 are used Bit [14]: 1: ARC enabled for this Tech and Baudrate. 0: ARC disabled for this Tech and Baudrate Bits[13:10] = RFU Bit [9] = Enable the IIR filter. Bits[8:7] = MF_GAIN (this value will be applied to the SIGPR_RM_TECH register, applies as soon as the ARC is enabled) Bits[6:0] = DPC_SIGNAL_DETECT_TH_OVR_VAL (this value will be applied to the DGRM_RSSI register, applies as soon as the ARC is enabled)

Note: The IIR settings define an all pass filter with approximately -10 dB gain. This can be used to limit the LMA sensitivity of the RX.

9.24.115 ARC_RM_A212 (0148h)

This is the setting for type A-212.

Table 243. ARC_RM_A212 (address 0148h) EEPROM configuration bit description

Address (hex)	Function	Bit	Description
150	RM_RX_ARC_4	15:0	Bit[15] 0: ARC settings always apply, bits 0..9 from the table ARC_RM_A212 are used 1: ARC settings during FDT, bits 0..9 of table ARC_RM_A212 are used, else settings will be used from LoadProtocol A212 Bits[14:10] = RFU Bit [9] = Enable the IIR filter. Bits[8:7] = MF_GAIN (this value will be applied to the SIGPR_RM_TECH register, applies as soon as the ARC is enabled) Bits[6:0] = DPC_SIGNAL_DETECT_TH_OVR_VAL (this value will be applied to the DGRM_RSSI register, applies as soon as the ARC is enabled)
14E	RM_RX_ARC_3	15:0	Bit[15] 0: ARC settings always apply, bits 0..9 from the table ARC_RM_A212 are used 1: ARC settings during FDT, bits 0..9 of table ARC_RM_A212 are used, else settings will be used from LoadProtocol A212 Bits[14:10] = RFU Bit [9] = Enable the IIR filter. Bits[8:7] = MF_GAIN (this value will be applied to the SIGPR_RM_TECH register, applies as soon as the ARC is enabled) Bits[6:0] = DPC_SIGNAL_DETECT_TH_OVR_VAL (this value will be applied to the DGRM_RSSI register, applies as soon as the ARC is enabled)

Table 243. ARC_RM_A212 (address 0148h) EEPROM configuration bit description...continued

Address (hex)	Function	Bit	Description
14C	RM_RX_ARC_2	15:0	Bit[15] 0: ARC settings always apply, bits 0..9 from the table ARC_RM_A212 are used 1: ARC settings during FDT, bits 0..9 of table ARC_RM_A212 are used, else settings will be used from LoadProtocol A212 Bits[14:10] = RFU Bit [9] = Enable the IIR filter. Bits[8:7] = MF_GAIN (this value will be applied to the SIGPR_RM_TECH register, applies as soon as the ARC is enabled) Bits[6:0] = DPC_SIGNAL_DETECT_TH_OVR_VAL (this value will be applied to the DGRM_RSSI register, applies as soon as the ARC is enabled)
14A	RM_RX_ARC_1	15:0	Bit[15] 0: ARC settings always apply, bits 0..9 from the table ARC_RM_A212 are used 1: ARC settings during FDT, bits 0..9 of table ARC_RM_A212 are used, else settings will be used from LoadProtocol A212 Bits[14:10] = RFU Bit [9] = Enable the IIR filter. Bits[8:7] = MF_GAIN (this value will be applied to the SIGPR_RM_TECH register, applies as soon as the ARC is enabled) Bits[6:0] = DPC_SIGNAL_DETECT_TH_OVR_VAL (this value will be applied to the DGRM_RSSI register, applies as soon as the ARC is enabled)
148	RM_RX_ARC_0	15:0	Bit[15] 0: ARC settings always apply 1: ARC settings applicable during FDT Bit [14]: 1: ARC Enabled for this Tech and Baudrate. 0: ARC disabled for this Tech and Baudrate Bits[13:10] = RFU Bit [9] = Enable the IIR filter. Bits[8:7] = MF_GAIN (this value will be applied to the SIGPR_RM_TECH register, applies as soon as the ARC is enabled) Bits[6:0] = DPC_SIGNAL_DETECT_TH_OVR_VAL (this value will be applied to the DGRM_RSSI register, applies as soon as the ARC is enabled)

Note: The IIR settings define an all pass filter with approximately -10 dB gain. This can be used to limit the LMA sensitivity of the RX.

Note: Bit15 of all RM_RX_ARC_n is recommended to be "0" always.

9.24.116 ARC_RM_A424 (0152h)

This is the setting for type A-424.

Table 244. ARC_RM_A424 (address 0152h) EEPROM configuration bit description

Address (hex)	Function	Bit	Description
15A	RM_RX_ARC_4	15:0	<p>Bit[15]</p> <p>0: ARC settings always apply, bits 0..9 from the table ARC_RM_A424 are used 1: ARC settings during FDT, bits 0..9 of table ARC_RM_A424 are used, else settings will be used from LoadProtocol A424</p> <p>Bit [14]: 1: ARC Enabled for this Tech and Baudrate. 0: ARC disabled for this Tech and Baudrate</p> <p>Bits[13:10] = RFU</p> <p>Bit [9] = Enable the IIR filter.</p> <p>Bits[8:7] = MF_GAIN (this value will be applied to the SIGPR_RM_TECH register, applies as soon as the ARC is enabled)</p> <p>Bits[6:0] = DPC_SIGNAL_DETECT_TH_OVR_VAL (this value will be applied to the DGRM_RSSI register, applies as soon as the ARC is enabled)</p>
158	RM_RX_ARC_3	15:0	<p>Bit[15]</p> <p>0: ARC settings always apply, bits 0..9 from the table ARC_RM_A424 are used 1: ARC settings during FDT, bits 0..9 of table ARC_RM_A424 are used, else settings will be used from LoadProtocol A424</p> <p>Bits[14:10] = RFU</p> <p>Bit [9] = Enable the IIR filter.</p> <p>Bits[8:7] = MF_GAIN (this value will be applied to the SIGPR_RM_TECH register, applies as soon as the ARC is enabled)</p> <p>Bits[6:0] = DPC_SIGNAL_DETECT_TH_OVR_VAL (this value will be applied to the DGRM_RSSI register, applies as soon as the ARC is enabled)</p>
156	RM_RX_ARC_2	15:0	<p>Bit[15]</p> <p>0: ARC settings always apply, bits 0..9 from the table ARC_RM_A424 are used 1: ARC settings during FDT, bits 0..9 of table ARC_RM_A424 are used, else settings will be used from LoadProtocol A424</p> <p>Bits[14:10] = RFU</p> <p>Bit [9] = Enable the IIR filter.</p> <p>Bits[8:7] = MF_GAIN (this value will be applied to the SIGPR_RM_TECH register, applies as soon as the ARC is enabled)</p> <p>Bits[6:0] = DPC_SIGNAL_DETECT_TH_OVR_VAL (this value will be applied to the DGRM_RSSI register, applies as soon as the ARC is enabled)</p>
154	RM_RX_ARC_1	15:0	<p>Bit[15]</p> <p>0: ARC settings always apply, bits 0..9 from the table ARC_RM_A424 are used 1: ARC settings during FDT, bits 0..9 of table ARC_RM_A424 are used, else settings will be used from LoadProtocol A424</p> <p>Bits[14:10] = RFU</p> <p>Bit [9] = Enable the IIR filter.</p> <p>Bits[8:7] = MF_GAIN (this value will be applied to the SIGPR_RM_TECH register, applies as soon as the ARC is enabled)</p> <p>Bits[6:0] = DPC_SIGNAL_DETECT_TH_OVR_VAL (this value will be applied to the DGRM_RSSI register, applies as soon as the ARC is enabled)</p>

Table 244. ARC_RM_A424 (address 0152h) EEPROM configuration bit description...continued

Address (hex)	Function	Bit	Description
152	RM_RX_ARC_0	15:0	Bit[15] 0: ARC settings always apply 1: ARC settings applicable during FDT and DPC change Bits[14:10] = RFU Bit [9] = Enable the IIR filter. Bits[8:7] = MF_GAIN (this value will be applied to the SIGPR_RM_TECH register, applies as soon as the ARC is enabled) Bits[6:0] = DPC_SIGNAL_DETECT_TH_OVR_VAL (this value will be applied to the DGRM_RSSI register, applies as soon as the ARC is enabled)

Note: The IIR settings define an all pass filter with approximately -10 dB gain. This can be used to limit the LMA sensitivity of the RX.

Note: Bit15 of all RM_RX_ARC_n is recommended to be "0" always.

9.24.117 ARC_RM_A848 (015Ch)

This is the setting for type A-848.

Table 245. ARC_RM_A848 (address 015Ch) EEPROM configuration bit description

Address (hex)	Function	Bit	Description
164	RM_RX_ARC_4	15:0	Bit[15] 0: ARC settings always apply, bits 0..9 from the table ARC_RM_A848 are used 1: ARC settings during FDT, bits 0..9 of table ARC_RM_A848 are used, else settings will be used from LoadProtocol A848 Bits[14:10] = RFU Bit [9] = Enable the IIR filter. Bits[8:7] = MF_GAIN (this value will be applied to the SIGPR_RM_TECH register, applies as soon as the ARC is enabled) Bits[6:0] = DPC_SIGNAL_DETECT_TH_OVR_VAL (this value will be applied to the DGRM_RSSI register, applies as soon as the ARC is enabled)
162	RM_RX_ARC_3	15:0	Bit[15] 0: ARC settings always apply, bits 0..9 from the table ARC_RM_A848 are used 1: ARC settings during FDT, bits 0..9 of table ARC_RM_A848 are used, else settings will be used from LoadProtocol A848 Bits[14:10] = RFU Bit [9] = Enable the IIR filter. Bits[8:7] = MF_GAIN (this value will be applied to the SIGPR_RM_TECH register, applies as soon as the ARC is enabled) Bits[6:0] = DPC_SIGNAL_DETECT_TH_OVR_VAL (this value will be applied to the DGRM_RSSI register, applies as soon as the ARC is enabled)

Table 245. ARC_RM_A848 (address 015Ch) EEPROM configuration bit description...continued

Address (hex)	Function	Bit	Description
160	RM_RX_ARC_2	15:0	Bit[15] 0: ARC settings always apply, bits 0...9 from the table ARC_RM_A848 are used 1: ARC settings during FDT, bits 0..9 of table ARC_RM_A848 are used, else settings will be used from LoadProtocol A848 Bits[14:10] = RFU Bit [9] = Enable the IIR filter. Bits[8:7] = MF_GAIN (this value will be applied to the SIGPR_RM_TECH register, applies as soon as the ARC is enabled) Bits[6:0] = DPC_SIGNAL_DETECT_TH_OVR_VAL (this value will be applied to the DGRM_RSSI register, applies as soon as the ARC is enabled)
15E	RM_RX_ARC_1	15:0	Bit[15] 0: ARC settings always apply, bits 0...9 from the table ARC_RM_A848 are used 1: ARC settings during FDT, bits 0..9 of table ARC_RM_A848 are used, else settings will be used from LoadProtocol A848 Bits[14:10] = RFU Bit [9] = Enable the IIR filter. Bits[8:7] = MF_GAIN (this value will be applied to the SIGPR_RM_TECH register, applies as soon as the ARC is enabled) Bits[6:0] = DPC_SIGNAL_DETECT_TH_OVR_VAL (this value will be applied to the DGRM_RSSI register, applies as soon as the ARC is enabled)
15C	RM_RX_ARC_0	15:0	Bit[15] 0: ARC settings always apply 1: ARC settings applicable during FDT and DPC change Bit [14]: 1: ARC Enabled for this Tech and Baudrate. 0: ARC disabled for this Tech and Baudrate Bits[13:10] = RFU Bit [9] = Enable the IIR filter. Bits[8:7] = MF_GAIN (this value will be applied to the SIGPR_RM_TECH register, applies as soon as the ARC is enabled) Bits[6:0] = DPC_SIGNAL_DETECT_TH_OVR_VAL (this value will be applied to the DGRM_RSSI register, applies as soon as the ARC is enabled)

Note: The IIR settings define an all pass filter with approximately -10 dB gain. This can be used to limit the LMA sensitivity of the RX.

Note: Bit15 of all RM_RX_ARC_n is recommended to be "0" always.

9.24.118 ARC_RM_B106 (0166h)

This is the setting for type B-106.

Table 246. ARC_RM_B106 (address 0166h) EEPROM configuration bit description

Address (hex)	Function	Bit	Description
16E	RM_RX_ARC_4	15:0	<p>Bit[15]</p> <p>0: ARC settings always apply, bits 0...9 from the table ARC_RM_B106 are used 1: ARC settings during FDT, bits 0..9 of table ARC_RM_B106 are used, else settings will be used from LoadProtocol B106</p> <p>Bits[14:10] = RFU</p> <p>Bit [9] = Enable the IIR filter.</p> <p>Bits[8:7] = MF_GAIN (this value will be applied to the SIGPR_RM_TECH register, applies as soon as the ARC is enabled)</p> <p>Bits[6:0] = DPC_SIGNAL_DETECT_TH_OVR_VAL (this value will be applied to the DGRM_RSSI register, applies as soon as the ARC is enabled)</p>
16C	RM_RX_ARC_3	15:0	<p>Bit[15]</p> <p>0: ARC settings always apply, bits 0...9 from the table ARC_RM_B106 are used 1: ARC settings during FDT, bits 0..9 of table ARC_RM_B106 are used, else settings will be used from LoadProtocol B106</p> <p>Bits[14:10] = RFU</p> <p>Bit [9] = Enable the IIR filter.</p> <p>Bits[8:7] = MF_GAIN (this value will be applied to the SIGPR_RM_TECH register, applies as soon as the ARC is enabled)</p> <p>Bits[6:0] = DPC_SIGNAL_DETECT_TH_OVR_VAL (this value will be applied to the DGRM_RSSI register, applies as soon as the ARC is enabled)</p>
16A	RM_RX_ARC_2	15:0	<p>Bit[15]</p> <p>0: ARC settings always apply, bits 0...9 from the table ARC_RM_B106 are used 1: ARC settings during FDT, bits 0..9 of table ARC_RM_B106 are used, else settings will be used from LoadProtocol B106</p> <p>Bits[14:10] = RFU</p> <p>Bit [9] = Enable the IIR filter.</p> <p>Bits[8:7] = MF_GAIN (this value will be applied to the SIGPR_RM_TECH register, applies as soon as the ARC is enabled)</p> <p>Bits[6:0] = DPC_SIGNAL_DETECT_TH_OVR_VAL (this value will be applied to the DGRM_RSSI register, applies as soon as the ARC is enabled)</p>
168	RM_RX_ARC_1	15:0	<p>Bit[15]</p> <p>0: ARC settings always apply, bits 0...9 from the table ARC_RM_B106 are used 1: ARC settings during FDT, bits 0..9 of table ARC_RM_B106 are used, else settings will be used from LoadProtocol B106</p> <p>Bits[14:10] = RFU</p> <p>Bit [9] = Enable the IIR filter.</p> <p>Bits[8:7] = MF_GAIN (this value will be applied to the SIGPR_RM_TECH register, applies as soon as the ARC is enabled)</p> <p>Bits[6:0] = DPC_SIGNAL_DETECT_TH_OVR_VAL (this value will be applied to the DGRM_RSSI register, applies as soon as the ARC is enabled)</p>

Table 246. ARC_RM_B106 (address 0166h) EEPROM configuration bit description...continued

Address (hex)	Function	Bit	Description
166	RM_RX_ARC_0	15:0	Bit[15] 0: ARC settings always apply 1: ARC settings applicable during FDT and DPC change Bit [14]: 1: ARC Enabled for this Tech and Baudrate. 0: ARC disabled for this Tech and Baudrate Bits[13:10] = RFU Bit [9] = Enable the IIR filter. Bits[8:7] = MF_GAIN (this value will be applied to the SIGPR_RM_TECH register, applies as soon as the ARC is enabled) Bits[6:0] = DPC_SIGNAL_DETECT_TH_OVR_VAL (this value will be applied to the DGRM_RSSI register, applies as soon as the ARC is enabled)

Note: The IIR settings define an all pass filter with approximately -10 dB gain. This can be used to limit the LMA sensitivity of the RX.

Note: Bit15 of all RM_RX_ARC_n is recommended to be "0" always.

9.24.119 ARC_RM_B212 (0170h)

This is the setting for type B-212.

Table 247. ARC_RM_B212 (address 0170h) EEPROM configuration bit description

Address (hex)	Function	Bit	Description
178	RM_RX_ARC_4	15:0	Bit[15] 0: ARC settings always apply, bits 0...9 from the table ARC_RM_B212 are used 1: ARC settings during FDT, bits 0..9 of table ARC_RM_B212 are used, else settings will be used from LoadProtocol B212 Bits[14:10] = RFU Bit [9] = Enable the IIR filter. Bits[8:7] = MF_GAIN (this value will be applied to the SIGPR_RM_TECH register, applies as soon as the ARC is enabled) Bits[6:0] = DPC_SIGNAL_DETECT_TH_OVR_VAL (this value will be applied to the DGRM_RSSI register, applies as soon as the ARC is enabled)
176	RM_RX_ARC_3	15:0	Bit[15] 0: ARC settings always apply, bits 0...9 from the table ARC_RM_B212 are used 1: ARC settings during FDT, bits 0..9 of table ARC_RM_B212 are used, else settings will be used from LoadProtocol B212 Bits[14:10] = RFU Bit [9] = Enable the IIR filter. Bits[8:7] = MF_GAIN (this value will be applied to the SIGPR_RM_TECH register, applies as soon as the ARC is enabled) Bits[6:0] = DPC_SIGNAL_DETECT_TH_OVR_VAL (this value will be applied to the DGRM_RSSI register, applies as soon as the ARC is enabled)

Table 247. ARC_RM_B212 (address 0170h) EEPROM configuration bit description...continued

Address (hex)	Function	Bit	Description
174	RM_RX_ARC_2	15:0	Bit[15] 0: ARC settings always apply, bits 0...9 from the table ARC_RM_B212 are used 1: ARC settings during FDT, bits 0..9 of table ARC_RM_B212 are used, else settings will be used from LoadProtocol B212 Bits[14:10] = RFU Bit [9] = Enable the IIR filter. Bits[8:7] = MF_GAIN (this value will be applied to the SIGPR_RM_Tech register, applies as soon as the ARC is enabled) Bits[6:0] = DPC_SIGNAL_DETECT_TH_OVR_VAL (this value will be applied to the DGRM_RSSI register, applies as soon as the ARC is enabled)
172	RM_RX_ARC_1	15:0	Bit[15] 0: ARC settings always apply, bits 0...9 from the table ARC_RM_B212 are used 1: ARC settings during FDT, bits 0..9 of table ARC_RM_B212 are used, else settings will be used from LoadProtocol B212 Bits[14:10] = RFU Bit [9] = Enable the IIR filter. Bits[8:7] = MF_GAIN (this value will be applied to the SIGPR_RM_Tech register, applies as soon as the ARC is enabled) Bits[6:0] = DPC_SIGNAL_DETECT_TH_OVR_VAL (this value will be applied to the DGRM_RSSI register, applies as soon as the ARC is enabled)
170	RM_RX_ARC_0	15:0	Bit[15] 0: ARC settings always apply 1: ARC settings applicable during FDT and DPC change Bit [14]: 1: ARC Enabled for this Tech and Baudrate. 0: ARC disabled for this Tech and Baudrate Bits[13:10] = RFU Bit [9] = Enable the IIR filter. Bits[8:7] = MF_GAIN (this value will be applied to the SIGPR_RM_Tech register, applies as soon as the ARC is enabled) Bits[6:0] = DPC_SIGNAL_DETECT_TH_OVR_VAL (this value will be applied to the DGRM_RSSI register, applies as soon as the ARC is enabled)

Note: The IIR settings define an all pass filter with approximately -10 dB gain. This can be used to limit the LMA sensitivity of the RX.

Note: Bit15 of all RM_RX_ARC_n is recommended to be "0" always.

9.24.120 ARC_RM_B424 (017Ah)

This is the setting for type B-424.

Table 248. ARC_RM_B424 (address 017Ah) EEPROM configuration bit description

Address (hex)	Function	Bit	Description
182	RM_RX_ARC_4	15:0	Bit[15] 0: ARC settings always apply, bits 0..9 from the table ARC_RM_A212 are used 1: ARC settings during FDT, bits 0..9 of table ARC_RM_A212 are used, else settings will be used from LoadProtocol A212 Bits[14:10] = RFU Bit [9] = Enable the IIR filter. Bits[8:7] = MF_GAIN (this value will be applied to the SIGPR_RM_TECH register, applies as soon as the ARC is enabled) Bits[6:0] = DPC_SIGNAL_DETECT_TH_OVR_VAL (this value will be applied to the DGRM_RSSI register, applies as soon as the ARC is enabled)
180	RM_RX_ARC_3	15:0	Bit[15] 0: ARC settings always apply, bits 0..9 from the table ARC_RM_A212 are used 1: ARC settings during FDT, bits 0..9 of table ARC_RM_A212 are used, else settings will be used from LoadProtocol A212 Bits[14:10] = RFU Bit [9] = Enable the IIR filter. Bits[8:7] = MF_GAIN (this value will be applied to the SIGPR_RM_TECH register, applies as soon as the ARC is enabled) Bits[6:0] = DPC_SIGNAL_DETECT_TH_OVR_VAL (this value will be applied to the DGRM_RSSI register, applies as soon as the ARC is enabled)
17E	RM_RX_ARC_2	15:0	Bit[15] 0: ARC settings always apply, bits 0..9 from the table ARC_RM_A212 are used 1: ARC settings during FDT, bits 0..9 of table ARC_RM_A212 are used, else settings will be used from LoadProtocol A212 Bits[14:10] = RFU Bit [9] = Enable the IIR filter. Bits[8:7] = MF_GAIN (this value will be applied to the SIGPR_RM_TECH register, applies as soon as the ARC is enabled) Bits[6:0] = DPC_SIGNAL_DETECT_TH_OVR_VAL (this value will be applied to the DGRM_RSSI register, applies as soon as the ARC is enabled)
17C	RM_RX_ARC_1	15:0	Bit[15] 0: ARC settings always apply, bits 0..9 from the table ARC_RM_A212 are used 1: ARC settings during FDT, bits 0..9 of table ARC_RM_A212 are used, else settings will be used from LoadProtocol A212 Bits[14:10] = RFU Bit [9] = Enable the IIR filter. Bits[8:7] = MF_GAIN (this value will be applied to the SIGPR_RM_TECH register, applies as soon as the ARC is enabled) Bits[6:0] = DPC_SIGNAL_DETECT_TH_OVR_VAL (this value will be applied to the DGRM_RSSI register, applies as soon as the ARC is enabled)

Table 248. ARC_RM_B424 (address 017Ah) EEPROM configuration bit description...continued

Address (hex)	Function	Bit	Description
17A	RM_RX_ARC_0	15:0	Bit[15] 0: ARC settings always apply 1: ARC settings applicable during FDT and DPC change Bit [14]: 1: ARC Enabled for this Tech and Baudrate. 0: ARC disabled for this Tech and Baudrate Bits[13:10] = RFU Bit [9] = Enable the IIR filter. Bits[8:7] = MF_GAIN (this value will be applied to the SIGPR_RM_TECH register, applies as soon as the ARC is enabled) Bits[6:0] = DPC_SIGNAL_DETECT_TH_OVR_VAL (this value will be applied to the DGRM_RSSI register, applies as soon as the ARC is enabled)

Note: The IIR settings define an all pass filter with approximately -10 dB gain. This can be used to limit the LMA sensitivity of the RX.

Note: Bit15 of all RM_RX_ARC_n is recommended to be "0" always.

9.24.121 ARC_RM_B848 (0184h)

This is the setting for type B-848.

Table 249. ARC_RM_B848 (address 0184h) EEPROM configuration bit description

Address (hex)	Function	Bit	Description
18C	RM_RX_ARC_4	15:0	Bit[15] 0: ARC settings always apply, bits 0...9 from the table ARC_RM_B848 are used 1: ARC settings during FDT, bits 0..9 of table ARC_RM_B848 are used, else settings will be used from LoadProtocol B848 Bits[14:10] = RFU Bit [9] = Enable the IIR filter. Bits[8:7] = MF_GAIN (this value will be applied to the SIGPR_RM_TECH register, applies as soon as the ARC is enabled) Bits[6:0] = DPC_SIGNAL_DETECT_TH_OVR_VAL (this value will be applied to the DGRM_RSSI register, applies as soon as the ARC is enabled)
18A	RM_RX_ARC_3	15:0	Bit[15] 0: ARC settings always apply, bits 0...9 from the table ARC_RM_B848 are used 1: ARC settings during FDT, bits 0..9 of table ARC_RM_B848 are used, else settings will be used from LoadProtocol B848 Bits[14:10] = RFU Bit [9] = Enable the IIR filter. Bits[8:7] = MF_GAIN (this value will be applied to the SIGPR_RM_TECH register, applies as soon as the ARC is enabled) Bits[6:0] = DPC_SIGNAL_DETECT_TH_OVR_VAL (this value will be applied to the DGRM_RSSI register, applies as soon as the ARC is enabled)

Table 249. ARC_RM_B848 (address 0184h) EEPROM configuration bit description...continued

Address (hex)	Function	Bit	Description
188	RM_RX_ARC_2	15:0	Bit[15] 0: ARC settings always apply, bits 0..9 from the table ARC_RM_B848 are used 1: ARC settings during FDT, bits 0..9 of table ARC_RM_B848 are used, else settings will be used from LoadProtocol B848 Bits[14:10] = RFU Bit [9] = Enable the IIR filter. Bits[8:7] = MF_GAIN (this value will be applied to the SIGPR_RM_TECH register, applies as soon as the ARC is enabled) Bits[6:0] = DPC_SIGNAL_DETECT_TH_OVR_VAL (this value will be applied to the DGRM_RSSI register, applies as soon as the ARC is enabled)
186	RM_RX_ARC_1	15:0	Bit[15] 0: ARC settings always apply, bits 0..9 from the table ARC_RM_B848 are used 1: ARC settings during FDT, bits 0..9 of table ARC_RM_B848 are used, else settings will be used from LoadProtocol B848 Bits[14:10] = RFU Bit [9] = Enable the IIR filter. Bits[8:7] = MF_GAIN (this value will be applied to the SIGPR_RM_TECH register, applies as soon as the ARC is enabled) Bits[6:0] = DPC_SIGNAL_DETECT_TH_OVR_VAL (this value will be applied to the DGRM_RSSI register, applies as soon as the ARC is enabled)
184	RM_RX_ARC_0	15:0	Bit[15] 0: ARC settings always apply 1: ARC settings applicable during FDT and DPC change Bit [14]: 1: ARC Enabled for this Tech and Baudrate. 0: ARC disabled for this Tech and Baudrate Bits[13:10] = RFU Bit [9] = Enable the IIR filter. Bits[8:7] = MF_GAIN (this value will be applied to the SIGPR_RM_TECH register, applies as soon as the ARC is enabled) Bits[6:0] = DPC_SIGNAL_DETECT_TH_OVR_VAL (this value will be applied to the DGRM_RSSI register, applies as soon as the ARC is enabled)

Note: The IIR settings define an all pass filter with approximately -10 dB gain. This can be used to limit the LMA sensitivity of the RX.

Note: Bit15 of all RM_RX_ARC_n is recommended to be "0" always.

9.24.122 ARC_RM_F212 (018Eh)

This is the setting for type F-212.

Table 250. ARC_RM_F212 (address 018Eh) EEPROM configuration bit description

Address (hex)	Function	Bit	Description
196	RM_RX_ARC_4	15:0	<p>Bit[15]</p> <p>0: ARC settings always apply, bits 0...9 from the table ARC_RM_F212 are used 1: ARC settings during FDT, bits 0..9 of table ARC_RM_F212 are used, else settings will be used from LoadProtocol F212</p> <p>Bits[14:10] = RFU</p> <p>Bit [9] = Enable the IIR filter.</p> <p>Bits[8:7] = MF_GAIN (this value will be applied to the SIGPR_RM_TECH register, applies as soon as the ARC is enabled)</p> <p>Bits[6:0] = DPC_SIGNAL_DETECT_TH_OVR_VAL (this value will be applied to the DGRM_RSSI register, applies as soon as the ARC is enabled)</p>
194	RM_RX_ARC_3	15:0	<p>Bit[15]</p> <p>0: ARC settings always apply, bits 0...9 from the table ARC_RM_F212 are used 1: ARC settings during FDT, bits 0..9 of table ARC_RM_F212 are used, else settings will be used from LoadProtocol F212</p> <p>Bits[14:10] = RFU</p> <p>Bit [9] = Enable the IIR filter.</p> <p>Bits[8:7] = MF_GAIN (this value will be applied to the SIGPR_RM_TECH register, applies as soon as the ARC is enabled)</p> <p>Bits[6:0] = DPC_SIGNAL_DETECT_TH_OVR_VAL (this value will be applied to the DGRM_RSSI register, applies as soon as the ARC is enabled)</p>
192	RM_RX_ARC_2	15:0	<p>Bit[15]</p> <p>0: ARC settings always apply, bits 0...9 from the table ARC_RM_F212 are used 1: ARC settings during FDT, bits 0..9 of table ARC_RM_F212 are used, else settings will be used from LoadProtocol F212</p> <p>Bits[14:10] = RFU</p> <p>Bit [9] = Enable the IIR filter.</p> <p>Bits[8:7] = MF_GAIN (this value will be applied to the SIGPR_RM_TECH register, applies as soon as the ARC is enabled)</p> <p>Bits[6:0] = DPC_SIGNAL_DETECT_TH_OVR_VAL (this value will be applied to the DGRM_RSSI register, applies as soon as the ARC is enabled)</p>
190	RM_RX_ARC_1	15:0	<p>Bit[15]</p> <p>0: ARC settings always apply, bits 0...9 from the table ARC_RM_F212 are used 1: ARC settings during FDT, bits 0..9 of table ARC_RM_F212 are used, else settings will be used from LoadProtocol F212</p> <p>Bits[14:10] = RFU</p> <p>Bit [9] = Enable the IIR filter.</p> <p>Bits[8:7] = MF_GAIN (this value will be applied to the SIGPR_RM_TECH register, applies as soon as the ARC is enabled)</p> <p>Bits[6:0] = DPC_SIGNAL_DETECT_TH_OVR_VAL (this value will be applied to the DGRM_RSSI register, applies as soon as the ARC is enabled)</p>

Table 250. ARC_RM_F212 (address 018Eh) EEPROM configuration bit description...continued

Address (hex)	Function	Bit	Description
18E	RM_RX_ARC_0	15:0	Bit[15] 0: ARC settings always apply 1: ARC settings applicable during FDT and DPC change Bit [14]: 1: ARC Enabled for this Tech and Baudrate. 0: ARC disabled for this Tech and Baudrate Bits[13:10] = RFU Bit [9] = Enable the IIR filter. Bits[8:7] = MF_GAIN (this value will be applied to the SIGPR_RM_TECH register, applies as soon as the ARC is enabled) Bits[6:0] = DPC_SIGNAL_DETECT_TH_OVR_VAL (this value will be applied to the DGRM_RSSI register, applies as soon as the ARC is enabled)

Note: The IIR settings define an all pass filter with approximately -10 dB gain. This can be used to limit the LMA sensitivity of the RX.

Note: Bit15 of all RM_RX_ARC_n is recommended to be "0" always.

9.24.123 ARC_RM_F424 (0198h)

This is the setting for type F-424.

Table 251. ARC_RM_F424 (address 0198h) EEPROM configuration bit description

Address (hex)	Function	Bit	Description
1A0	RM_RX_ARC_4	15:0	Bit[15] 0: ARC settings always apply, bits 0...9 from the table ARC_RM_F424 are used 1: ARC settings during FDT, bits 0..9 of table ARC_RM_F424 are used, else settings will be used from LoadProtocol F424 Bits[14:10] = RFU Bit [9] = Enable the IIR filter. Bits[8:7] = MF_GAIN (this value will be applied to the SIGPR_RM_TECH register, applies as soon as the ARC is enabled) Bits[6:0] = DPC_SIGNAL_DETECT_TH_OVR_VAL (this value will be applied to the DGRM_RSSI register, applies as soon as the ARC is enabled)
19E	RM_RX_ARC_3	15:0	Bit[15] 0: ARC settings always apply, bits 0...9 from the table ARC_RM_F424 are used 1: ARC settings during FDT, bits 0..9 of table ARC_RM_F424 are used, else settings will be used from LoadProtocol F424 Bits[14:10] = RFU Bit [9] = Enable the IIR filter. Bits[8:7] = MF_GAIN (this value will be applied to the SIGPR_RM_TECH register, applies as soon as the ARC is enabled) Bits[6:0] = DPC_SIGNAL_DETECT_TH_OVR_VAL (this value will be applied to the DGRM_RSSI register, applies as soon as the ARC is enabled)

Table 251. ARC_RM_F424 (address 0198h) EEPROM configuration bit description...continued

Address (hex)	Function	Bit	Description
19C	RM_RX_ARC_2	15:0	Bit[15] 0: ARC settings always apply, bits 0..9 from the table ARC_RM_F424 are used 1: ARC settings during FDT, bits 0..9 of table ARC_RM_F424 are used, else settings will be used from LoadProtocol F424 Bits[14:10] = RFU Bit [9] = Enable the IIR filter. Bits[8:7] = MF_GAIN (this value will be applied to the SIGPR_RM_TECH register, applies as soon as the ARC is enabled) Bits[6:0] = DPC_SIGNAL_DETECT_TH_OVR_VAL (this value will be applied to the DGRM_RSSI register, applies as soon as the ARC is enabled)
19A	RM_RX_ARC_1	15:0	Bit[15] 0: ARC settings always apply, bits 0..9 from the table ARC_RM_F424 are used 1: ARC settings during FDT, bits 0..9 of table ARC_RM_F424 are used, else settings will be used from LoadProtocol F424 Bits[14:10] = RFU Bit [9] = Enable the IIR filter. Bits[8:7] = MF_GAIN (this value will be applied to the SIGPR_RM_TECH register, applies as soon as the ARC is enabled) Bits[6:0] = DPC_SIGNAL_DETECT_TH_OVR_VAL (this value will be applied to the DGRM_RSSI register, applies as soon as the ARC is enabled)
198	RM_RX_ARC_0	15:0	Bit[15] 0: ARC settings always apply 1: ARC settings applicable during FDT and DPC change Bit [14]: 1: ARC Enabled for this Tech and Baudrate. 0: ARC disabled for this Tech and Baudrate Bits[13:10] = RFU Bit [9] = Enable the IIR filter. Bits[8:7] = MF_GAIN (this value will be applied to the SIGPR_RM_TECH register, applies as soon as the ARC is enabled) Bits[6:0] = DPC_SIGNAL_DETECT_TH_OVR_VAL (this value will be applied to the DGRM_RSSI register, applies as soon as the ARC is enabled)

Note: The IIR settings define an all pass filter with approximately -10 dB gain. This can be used to limit the LMA sensitivity of the RX.

Note: Bit15 of all RM_RX_ARC_n is recommended to be "0" always.

9.24.124 ARC_RM_V_6p6 (01A2h)

This is the setting for type A-106.

Table 252. ARC_RM_V_6p6 (address 01A2h) EEPROM configuration bit description

Address (hex)	Function	Bit	Description
1AA	RM_RX_ARC_4	15:0	<p>Bit[15]</p> <p>0: ARC settings always apply, bits 0...9 from the table ARC_RM_V6P6 are used 1: ARC settings during FDT, bits 0..9 of table ARC_RM_V6P6 are used, else settings will be used from LoadProtocol V6P6</p> <p>Bits[14:10] = RFU</p> <p>Bit [9] = Enable the IIR filter.</p> <p>Bits[8:7] = MF_GAIN (this value will be applied to the SIGPR_RM_TECH register, applies as soon as the ARC is enabled)</p> <p>Bits[6:0] = DPC_SIGNAL_DETECT_TH_OVR_VAL (this value will be applied to the DGRM_RSSI register, applies as soon as the ARC is enabled)</p>
1A8	RM_RX_ARC_3	15:0	<p>Bit[15]</p> <p>0: ARC settings always apply, bits 0...9 from the table ARC_RM_V6P6 are used 1: ARC settings during FDT, bits 0..9 of table ARC_RM_V6P6 are used, else settings will be used from LoadProtocol V6P6</p> <p>Bits[14:10] = RFU</p> <p>Bit [9] = Enable the IIR filter.</p> <p>Bits[8:7] = MF_GAIN (this value will be applied to the SIGPR_RM_TECH register, applies as soon as the ARC is enabled)</p> <p>Bits[6:0] = DPC_SIGNAL_DETECT_TH_OVR_VAL (this value will be applied to the DGRM_RSSI register, applies as soon as the ARC is enabled)</p>
1A6	RM_RX_ARC_2	15:0	<p>Bit[15]</p> <p>0: ARC settings always apply, bits 0...9 from the table ARC_RM_V6P6 are used 1: ARC settings during FDT, bits 0..9 of table ARC_RM_V6P6 are used, else settings will be used from LoadProtocol V6P6</p> <p>Bits[14:10] = RFU</p> <p>Bit [9] = Enable the IIR filter.</p> <p>Bits[8:7] = MF_GAIN (this value will be applied to the SIGPR_RM_TECH register, applies as soon as the ARC is enabled)</p> <p>Bits[6:0] = DPC_SIGNAL_DETECT_TH_OVR_VAL (this value will be applied to the DGRM_RSSI register, applies as soon as the ARC is enabled)</p>
1A4	RM_RX_ARC_1	15:0	<p>Bit[15]</p> <p>0: ARC settings always apply, bits 0...9 from the table ARC_RM_V6P6 are used 1: ARC settings during FDT, bits 0..9 of table ARC_RM_V6P6 are used, else settings will be used from LoadProtocol V6P6</p> <p>Bits[14:10] = RFU</p> <p>Bit [9] = Enable the IIR filter.</p> <p>Bits[8:7] = MF_GAIN (this value will be applied to the SIGPR_RM_TECH register, applies as soon as the ARC is enabled)</p> <p>Bits[6:0] = DPC_SIGNAL_DETECT_TH_OVR_VAL (this value will be applied to the DGRM_RSSI register, applies as soon as the ARC is enabled)</p>

Table 252. ARC_RM_V_6p6 (address 01A2h) EEPROM configuration bit description...continued

Address (hex)	Function	Bit	Description
1A2	RM_RX_ARC_0	15:0	Bit[15] 0: ARC settings always apply 1: ARC settings applicable during FDT and DPC change Bit [14]: 1: ARC Enabled for this Tech and Baudrate. 0: ARC disabled for this Tech and Baudrate Bits[13:10] = RFU Bit [9] = Enable the IIR filter. Bits[8:7] = MF_GAIN (this value will be applied to the SIGPR_RM_TECH register, applies as soon as the ARC is enabled) Bits[6:0] = DPC_SIGNAL_DETECT_TH_OVR_VAL (this value will be applied to the DGRM_RSSI register, applies as soon as the ARC is enabled)

Note: The IIR settings define an all pass filter with approximately -10 dB gain. This can be used to limit the LMA sensitivity of the RX.

Note: Bit15 of all RM_RX_ARC_n is recommended to be "0" always.

9.24.125 ARC_RM_V_26 (01ACh)

This is the setting for type V 26.

Table 253. ARC_RM_V_26 (address 01ACh) EEPROM configuration bit description

Address (hex)	Function	Bit	Description
1B4	RM_RX_ARC_4	15:0	Bit[15] 0: ARC settings always apply, bits 0...9 from the table ARC_RM_V26 are used 1: ARC settings during FDT, bits 0..9 of table ARC_RM_V26 are used, else settings will be used from LoadProtocol V26 Bits[14:10] = RFU Bit [9] = Enable the IIR filter. Bits[8:7] = MF_GAIN (this value will be applied to the SIGPR_RM_TECH register, applies as soon as the ARC is enabled) Bits[6:0] = DPC_SIGNAL_DETECT_TH_OVR_VAL (this value will be applied to the DGRM_RSSI register, applies as soon as the ARC is enabled)
1B2	RM_RX_ARC_3	15:0	Bit[15] 0: ARC settings always apply, bits 0...9 from the table ARC_RM_V26 are used 1: ARC settings during FDT, bits 0..9 of table ARC_RM_V26 are used, else settings will be used from LoadProtocol V26 Bits[14:10] = RFU Bit [9] = Enable the IIR filter. Bits[8:7] = MF_GAIN (this value will be applied to the SIGPR_RM_TECH register, applies as soon as the ARC is enabled) Bits[6:0] = DPC_SIGNAL_DETECT_TH_OVR_VAL (this value will be applied to the DGRM_RSSI register, applies as soon as the ARC is enabled)

Table 253. ARC_RM_V_26 (address 01ACh) EEPROM configuration bit description...continued

Address (hex)	Function	Bit	Description
1B0	RM_RX_ARC_2	15:0	Bit[15] 0: ARC settings always apply, bits 0...9 from the table ARC_RM_V26 are used 1: ARC settings during FDT, bits 0..9 of table ARC_RM_V26 are used, else settings will be used from LoadProtocol V26 Bits[14:10] = RFU Bit [9] = Enable the IIR filter. Bits[8:7] = MF_GAIN (this value will be applied to the SIGPR_RM_TECH register, applies as soon as the ARC is enabled) Bits[6:0] = DPC_SIGNAL_DETECT_TH_OVR_VAL (this value will be applied to the DGRM_RSSI register, applies as soon as the ARC is enabled)
1AE	RM_RX_ARC_1	15:0	Bit[15] 0: ARC settings always apply, bits 0...9 from the table ARC_RM_V26 are used 1: ARC settings during FDT, bits 0..9 of table ARC_RM_V26 are used, else settings will be used from LoadProtocol V26 Bits[14:10] = RFU Bit [9] = Enable the IIR filter. Bits[8:7] = MF_GAIN (this value will be applied to the SIGPR_RM_TECH register, applies as soon as the ARC is enabled) Bits[6:0] = DPC_SIGNAL_DETECT_TH_OVR_VAL (this value will be applied to the DGRM_RSSI register, applies as soon as the ARC is enabled)
1AC	RM_RX_ARC_0	15:0	Bit[15] 0: ARC settings always apply 1: ARC settings applicable during FDT and DPC change Bit [14]: 1: ARC Enabled for this Tech and Baudrate. 0: ARC disabled for this Tech and Baudrate Bits[13:10] = RFU Bit [9] = Enable the IIR filter. Bits[8:7] = MF_GAIN (this value will be applied to the SIGPR_RM_TECH register, applies as soon as the ARC is enabled) Bits[6:0] = DPC_SIGNAL_DETECT_TH_OVR_VAL (this value will be applied to the DGRM_RSSI register, applies as soon as the ARC is enabled)

Note: The IIR settings define an all pass filter with approximately -10 dB gain. This can be used to limit the LMA sensitivity of the RX.

Note: Bit15 of all RM_RX_ARC_n is recommended to be "0" always.

9.24.126 ARC_RM_V53 (01B6h)

This is the setting for type V53.

Table 254. ARC_RM_V53(address 01B6h) EEPROM configuration bit description

Address (hex)	Function	Bit	Description
1BE	RM_RX_ARC_4	15:0	Bit[15] 0: ARC settings always apply, bits 0..9 from the table ARC_RM_V53 are used 1: ARC settings during FDT, bits 0..9 of table ARC_RM_V53 are used, else settings will be used from LoadProtocol V53 Bits[14:10] = RFU Bit [9] = Enable the IIR filter. Bits[8:7] = MF_GAIN (this value will be applied to the SIGPR_RM_TECH register, applies as soon as the ARC is enabled) Bits[6:0] = DPC_SIGNAL_DETECT_TH_OVR_VAL (this value will be applied to the DGRM_RSSI register, applies as soon as the ARC is enabled)
1BC	RM_RX_ARC_3	15:0	Bit[15] 0: ARC settings always apply, bits 0..9 from the table ARC_RM_V53 are used 1: ARC settings during FDT, bits 0..9 of table ARC_RM_V53 are used, else settings will be used from LoadProtocol V53 Bits[14:10] = RFU Bit [9] = Enable the IIR filter. Bits[8:7] = MF_GAIN (this value will be applied to the SIGPR_RM_TECH register, applies as soon as the ARC is enabled) Bits[6:0] = DPC_SIGNAL_DETECT_TH_OVR_VAL (this value will be applied to the DGRM_RSSI register, applies as soon as the ARC is enabled)
1BA	RM_RX_ARC_2	15:0	Bit[15] 0: ARC settings always apply, bits 0..9 from the table ARC_RM_V53 are used 1: ARC settings during FDT, bits 0..9 of table ARC_RM_V53 are used, else settings will be used from LoadProtocol V53 Bits[14:10] = RFU Bit [9] = Enable the IIR filter. Bits[8:7] = MF_GAIN (this value will be applied to the SIGPR_RM_TECH register, applies as soon as the ARC is enabled) Bits[6:0] = DPC_SIGNAL_DETECT_TH_OVR_VAL (this value will be applied to the DGRM_RSSI register, applies as soon as the ARC is enabled)
1B8	RM_RX_ARC_1	15:0	Bit[15] 0: ARC settings always apply, bits 0..9 from the table ARC_RM_V53 are used 1: ARC settings during FDT, bits 0..9 of table ARC_RM_V53 are used, else settings will be used from LoadProtocol V53 Bits[14:10] = RFU Bit [9] = Enable the IIR filter. Bits[8:7] = MF_GAIN (this value will be applied to the SIGPR_RM_TECH register, applies as soon as the ARC is enabled) Bits[6:0] = DPC_SIGNAL_DETECT_TH_OVR_VAL (this value will be applied to the DGRM_RSSI register, applies as soon as the ARC is enabled)

Table 254. ARC_RM_V53(address 01B6h) EEPROM configuration bit description...continued

Address (hex)	Function	Bit	Description
1B6	RM_RX_ARC_0	15:0	Bit[15] 0: ARC settings always apply 1: ARC settings applicable during FDT and DPC change Bit [14]: 1: ARC Enabled for this Tech and Baudrate. 0: ARC disabled for this Tech and Baudrate Bits[13:10] = RFU Bit [9] = Enable the IIR filter. Bits[8:7] = MF_GAIN (this value will be applied to the SIGPR_RM_TECH register, applies as soon as the ARC is enabled) Bits[6:0] = DPC_SIGNAL_DETECT_TH_OVR_VAL (this value will be applied to the DGRM_RSSI register, applies as soon as the ARC is enabled)

Note: The IIR settings define an all pass filter with approximately -10 dB gain. This can be used to limit the LMA sensitivity of the RX.

Note: Bit15 of all RM_RX_ARC_n is recommended to be "0" always.

9.24.127 ARC_RM_V106 (01C0h)

This is the setting for type V106.

Table 255. ARC_RM_V106(address 01C0h) EEPROM configuration bit description

Address (hex)	Function	Bit	Description
1C8	RM_RX_ARC_4	15:0	Bit[15] 0: ARC settings always apply, bits 0..9 from the table ARC_RM_A212 are used 1: ARC settings during FDT, bits 0..9 of table ARC_RM_A212 are used, else settings will be used from LoadProtocol A212 Bits[14:10] = RFU Bit [9] = Enable the IIR filter. Bits[8:7] = MF_GAIN (this value will be applied to the SIGPR_RM_TECH register, applies as soon as the ARC is enabled) Bits[6:0] = DPC_SIGNAL_DETECT_TH_OVR_VAL (this value will be applied to the DGRM_RSSI register, applies as soon as the ARC is enabled)
1C6	RM_RX_ARC_3	15:0	Bit[15] 0: ARC settings always apply, bits 0..9 from the table ARC_RM_A212 are used 1: ARC settings during FDT, bits 0..9 of table ARC_RM_A212 are used, else settings will be used from LoadProtocol A212 Bits[14:10] = RFU Bit [9] = Enable the IIR filter. Bits[8:7] = MF_GAIN (this value will be applied to the SIGPR_RM_TECH register, applies as soon as the ARC is enabled) Bits[6:0] = DPC_SIGNAL_DETECT_TH_OVR_VAL (this value will be applied to the DGRM_RSSI register, applies as soon as the ARC is enabled)

Table 255. ARC_RM_V106(address 01C0h) EEPROM configuration bit description...continued

Address (hex)	Function	Bit	Description
1C4	RM_RX_ARC_2	15:0	Bit[15] 0: ARC settings always apply, bits 0...9 from the table ARC_RM_A212 are used 1: ARC settings during FDT, bits 0..9 of table ARC_RM_A212 are used, else settings will be used from LoadProtocol A212 Bits[14:10] = RFU Bit [9] = Enable the IIR filter. Bits[8:7] = MF_GAIN (this value will be applied to the SIGPR_RM_TECH register, applies as soon as the ARC is enabled) Bits[6:0] = DPC_SIGNAL_DETECT_TH_OVR_VAL (this value will be applied to the DGRM_RSSI register, applies as soon as the ARC is enabled)
1C2	RM_RX_ARC_1	15:0	Bit[15] 0: ARC settings always apply, bits 0...9 from the table ARC_RM_A212 are used 1: ARC settings during FDT, bits 0..9 of table ARC_RM_A212 are used, else settings will be used from LoadProtocol A212 Bits[14:10] = RFU Bit [9] = Enable the IIR filter. Bits[8:7] = MF_GAIN (this value will be applied to the SIGPR_RM_TECH register, applies as soon as the ARC is enabled) Bits[6:0] = DPC_SIGNAL_DETECT_TH_OVR_VAL (this value will be applied to the DGRM_RSSI register, applies as soon as the ARC is enabled)
1C0	RM_RX_ARC_0	15:0	Bit[15] 0: ARC settings always apply 1: ARC settings applicable during FDT and DPC change Bit [14]: 1: ARC Enabled for this Tech and Baudrate. 0: ARC disabled for this Tech and Baudrate Bits[13:10] = RFU Bit [9] = Enable the IIR filter. Bits[8:7] = MF_GAIN (this value will be applied to the SIGPR_RM_TECH register, applies as soon as the ARC is enabled) Bits[6:0] = DPC_SIGNAL_DETECT_TH_OVR_VAL (this value will be applied to the DGRM_RSSI register, applies as soon as the ARC is enabled)

Note: The IIR settings define an all pass filter with approximately -10 dB gain. This can be used to limit the LMA sensitivity of the RX.

Note: Bit15 of all RM_RX_ARC_n is recommended to be "0" always.

9.24.128 ARC_RM_V212 (01CAh)

This is the setting for type V212.

Table 256. ARC_RM_V212(address 01CAh) EEPROM configuration bit description

Address (hex)	Function	Bit	Description
1D2	RM_RX_ARC_4	15:0	Bit[15] 0: ARC settings always apply, bits 0..9 from the table ARC_RM_V212 are used 1: ARC settings during FDT, bits 0..9 of table ARC_RM_V212 are used, else settings will be used from LoadProtocol V212 Bits[14:10] = RFU Bit [9] = Enable the IIR filter. Bits[8:7] = MF_GAIN (this value will be applied to the SIGPR_RM_TECH register, applies as soon as the ARC is enabled) Bits[6:0] = DPC_SIGNAL_DETECT_TH_OVR_VAL (this value will be applied to the DGRM_RSSI register, applies as soon as the ARC is enabled)
1D0	RM_RX_ARC_3	15:0	Bit[15] 0: ARC settings always apply, bits 0..9 from the table ARC_RM_V212 are used 1: ARC settings during FDT, bits 0..9 of table ARC_RM_V212 are used, else settings will be used from LoadProtocol V212 Bits[14:10] = RFU Bit [9] = Enable the IIR filter. Bits[8:7] = MF_GAIN (this value will be applied to the SIGPR_RM_TECH register, applies as soon as the ARC is enabled) Bits[6:0] = DPC_SIGNAL_DETECT_TH_OVR_VAL (this value will be applied to the DGRM_RSSI register, applies as soon as the ARC is enabled)
1CE	RM_RX_ARC_2	15:0	Bit[15] 0: ARC settings always apply, bits 0..9 from the table ARC_RM_V212 are used 1: ARC settings during FDT, bits 0..9 of table ARC_RM_V212 are used, else settings will be used from LoadProtocol V212 Bits[14:10] = RFU Bit [9] = Enable the IIR filter. Bits[8:7] = MF_GAIN (this value will be applied to the SIGPR_RM_TECH register, applies as soon as the ARC is enabled) Bits[6:0] = DPC_SIGNAL_DETECT_TH_OVR_VAL (this value will be applied to the DGRM_RSSI register, applies as soon as the ARC is enabled)
1CC	RM_RX_ARC_1	15:0	Bit[15] 0: ARC settings always apply, bits 0..9 from the table ARC_RM_V212 are used 1: ARC settings during FDT, bits 0..9 of table ARC_RM_V212 are used, else settings will be used from LoadProtocol V212 Bits[14:10] = RFU Bit [9] = Enable the IIR filter. Bits[8:7] = MF_GAIN (this value will be applied to the SIGPR_RM_TECH register, applies as soon as the ARC is enabled) Bits[6:0] = DPC_SIGNAL_DETECT_TH_OVR_VAL (this value will be applied to the DGRM_RSSI register, applies as soon as the ARC is enabled)

Table 256. ARC_RM_V212(address 01CAh) EEPROM configuration bit description...continued

Address (hex)	Function	Bit	Description
1CA	RM_RX_ARC_0	15:0	Bit[15] 0: ARC settings always apply 1: ARC settings applicable during FDT and DPC change Bit [14]: 1: ARC Enabled for this Tech and Baudrate. 0: ARC disabled for this Tech and Baudrate Bits[13:10] = RFU Bit [9] = Enable the IIR filter. Bits[8:7] = MF_GAIN (this value will be applied to the SIGPR_RM_TECH register, applies as soon as the ARC is enabled) Bits[6:0] = DPC_SIGNAL_DETECT_TH_OVR_VAL (this value will be applied to the DGRM_RSSI register, applies as soon as the ARC is enabled)

Note: The IIR settings define an all pass filter with approximately -10 dB gain. This can be used to limit the LMA sensitivity of the RX.

Note: Bit15 of all RM_RX_ARC_n is recommended to be "0" always.

9.24.129 ARC_RM_180003m3_SC424_4Man (01D4h)

This is the setting for type 180003m3_SC424_4Man.

Table 257. ARC_RM_180003m3_SC424_4Man (address 01D4h) EEPROM configuration bit description

Address (hex)	Function	Bit	Description
1DC	RM_RX_ARC_4	15:0	Bit[15] 0: ARC settings always apply, bits 0...9 from the table ARC_RM_180003M3_SC424_4MAN are used 1: ARC settings during FDT, bits 0..9 of table ARC_RM_180003M3_SC424_4MAN are used, else settings will be used from LoadProtocol 180003M3_SC424_4MAN Bits[14:10] = RFU Bit [9] = Enable the IIR filter. Bits[8:7] = MF_GAIN (this value will be applied to the SIGPR_RM_TECH register, applies as soon as the ARC is enabled) Bits[6:0] = DPC_SIGNAL_DETECT_TH_OVR_VAL (this value will be applied to the DGRM_RSSI register, applies as soon as the ARC is enabled)
1DA	RM_RX_ARC_3	15:0	Bit[15] 0: ARC settings always apply, bits 0...9 from the table ARC_RM_180003M3_SC424_4MAN are used 1: ARC settings during FDT, bits 0..9 of table ARC_RM_180003M3_SC424_4MAN are used, else settings will be used from LoadProtocol 180003M3_SC424_4MAN Bits[14:10] = RFU Bit [9] = Enable the IIR filter. Bits[8:7] = MF_GAIN (this value will be applied to the SIGPR_RM_TECH register, applies as soon as the ARC is enabled) Bits[6:0] = DPC_SIGNAL_DETECT_TH_OVR_VAL (this value will be applied to the DGRM_RSSI register, applies as soon as the ARC is enabled)

Table 257. ARC_RM_180003m3_SC424_4Man (address 01D4h) EEPROM configuration bit description...continued

Address (hex)	Function	Bit	Description
1D8	RM_RX_ARC_2	15:0	Bit[15] 0: ARC settings always apply, bits 0...9 from the table ARC_RM_180003M3_SC424_4MAN are used 1: ARC settings during FDT, bits 0..9 of table ARC_RM_180003M3_SC424_4MAN are used, else settings will be used from LoadProtocol 180003M3_SC424_4MAN Bits[14:10] = RFU Bit [9] = Enable the IIR filter. Bits[8:7] = MF_GAIN (this value will be applied to the SIGPR_RM_TECH register, applies as soon as the ARC is enabled) Bits[6:0] = DPC_SIGNAL_DETECT_TH_OVR_VAL (this value will be applied to the DGRM_RSSI register, applies as soon as the ARC is enabled)
1D6	RM_RX_ARC_1	15:0	Bit[15] 0: ARC settings always apply, bits 0...9 from the table ARC_RM_180003M3_SC424_4MAN are used 1: ARC settings during FDT, bits 0..9 of table ARC_RM_180003M3_SC424_4MAN are used, else settings will be used from LoadProtocol 180003M3_SC424_4MAN Bits[14:10] = RFU Bit [9] = Enable the IIR filter. Bits[8:7] = MF_GAIN (this value will be applied to the SIGPR_RM_TECH register, applies as soon as the ARC is enabled) Bits[6:0] = DPC_SIGNAL_DETECT_TH_OVR_VAL (this value will be applied to the DGRM_RSSI register, applies as soon as the ARC is enabled)
1D4	RM_RX_ARC_0	15:0	Bit[15] 0: ARC settings always apply 1: ARC settings applicable during FDT and DPC change Bit [14]: 1: ARC Enabled for this Tech and Baudrate. 0: ARC disabled for this Tech and Baudrate Bits[13:10] = RFU Bit [9] = Enable the IIR filter. Bits[8:7] = MF_GAIN (this value will be applied to the SIGPR_RM_TECH register, applies as soon as the ARC is enabled) Bits[6:0] = DPC_SIGNAL_DETECT_TH_OVR_VAL (this value will be applied to the DGRM_RSSI register, applies as soon as the ARC is enabled)

Note: The IIR settings define an all pass filter with approximately -10 dB gain. This can be used to limit the LMA sensitivity of the RX.

Note: Bit15 of all RM_RX_ARC_n is recommended to be "0" always.

9.24.130 ARC_RM_180003m3_SC424_2Man (01DEh)

This is the setting for type 180003m3_SC424_2Man.

Table 258. ARC_RM_180003M3_SC424_2Man (address 01DEh) EEPROM configuration bit description

Address (hex)	Function	Bit	Description
1E6	RM_RX_ARC_4	15:0	<p>Bit[15]</p> <p>0: ARC settings always apply, bits 0...9 from the table ARC_RM_180003M3_SC424_2MAN are used</p> <p>1: ARC settings during FDT, bits 0..9 of table ARC_RM_180003M3_SC424_2MAN are used, else settings will be used from LoadProtocol 180003M3_SC424_2MAN</p> <p>Bits[14:10] = RFU</p> <p>Bit [9] = Enable the IIR filter.</p> <p>Bits[8:7] = MF_GAIN (this value will be applied to the SIGPR_RM_TECH register, applies as soon as the ARC is enabled)</p> <p>Bits[6:0] = DPC_SIGNAL_DETECT_TH_OVR_VAL (this value will be applied to the DGRM_RSSI register, applies as soon as the ARC is enabled)</p>
1E4	RM_RX_ARC_3	15:0	<p>Bit[15]</p> <p>0: ARC settings always apply, bits 0...9 from the table ARC_RM_180003M3_SC424_2MAN are used</p> <p>1: ARC settings during FDT, bits 0..9 of table ARC_RM_180003M3_SC424_2MAN are used, else settings will be used from LoadProtocol 180003M3_SC424_2MAN</p> <p>Bits[14:10] = RFU</p> <p>Bit [9] = Enable the IIR filter.</p> <p>Bits[8:7] = MF_GAIN (this value will be applied to the SIGPR_RM_TECH register, applies as soon as the ARC is enabled)</p> <p>Bits[6:0] = DPC_SIGNAL_DETECT_TH_OVR_VAL (this value will be applied to the DGRM_RSSI register, applies as soon as the ARC is enabled)</p>
1E2	RM_RX_ARC_2	15:0	<p>Bit[15]</p> <p>0: ARC settings always apply, bits 0...9 from the table ARC_RM_180003M3_SC424_2MAN are used</p> <p>1: ARC settings during FDT, bits 0..9 of table ARC_RM_180003M3_SC424_2MAN are used, else settings will be used from LoadProtocol 180003M3_SC424_2MAN</p> <p>Bits[14:9] = RFU</p> <p>Bits[8:7] = MF_GAIN (this value will be applied to the SIGPR_RM_TECH register, applies as soon as the ARC is enabled)</p> <p>Bits[6:0] = DPC_SIGNAL_DETECT_TH_OVR_VAL (this value will be applied to the DGRM_RSSI register, applies as soon as the ARC is enabled)</p>
1E0	RM_RX_ARC_1	15:0	<p>Bit[15]</p> <p>0: ARC settings always apply, bits 0...9 from the table ARC_RM_180003M3_SC424_2MAN are used</p> <p>1: ARC settings during FDT, bits 0..9 of table ARC_RM_180003M3_SC424_2MAN are used, else settings will be used from LoadProtocol 180003M3_SC424_2MAN</p> <p>Bits[14:10] = RFU</p> <p>Bit [9] = Enable the IIR filter.</p> <p>Bits[8:7] = MF_GAIN (this value will be applied to the SIGPR_RM_TECH register, applies as soon as the ARC is enabled)</p> <p>Bits[6:0] = DPC_SIGNAL_DETECT_TH_OVR_VAL (this value will be applied to the DGRM_RSSI register, applies as soon as the ARC is enabled)</p>

Table 258. ARC_RM_180003m3_SC424_2Man (address 01DEh) EEPROM configuration bit description...continued

Address (hex)	Function	Bit	Description
1DE	RM_RX_ARC_0	15:0	Bit[15] 0: ARC settings always apply 1: ARC settings applicable during FDT and DPC change Bit [14]: 1: ARC Enabled for this Tech and Baudrate. 0: ARC disabled for this Tech and Baudrate Bits[13:10] = RFU Bit [9] = Enable the IIR filter. Bits[8:7] = MF_GAIN (this value will be applied to the SIGPR_RM_TECH register, applies as soon as the ARC is enabled) Bits[6:0] = DPC_SIGNAL_DETECT_TH_OVR_VAL (this value will be applied to the DGRM_RSSI register, applies as soon as the ARC is enabled)

Note: The IIR settings define an all pass filter with approximately -10 dB gain. This can be used to limit the LMA sensitivity of the RX.

Note: Bit15 of all RM_RX_ARC_n is recommended to be "0" always.

9.24.131 ARC_RM_180003m3_SC848_4Man (01E8h)

This is the setting for type 180003m3_SC848_4Man.

Table 259. ARC_RM_180003m3_SC848_4Man (address 01E8h) EEPROM configuration bit description

Address (hex)	Function	Bit	Description
1F0	RM_RX_ARC_4	15:0	Bit[15] 0: ARC settings always apply, bits 0...9 from the table ARC_RM_180003M3_SC848_4MAN are used 1: ARC settings during FDT, bits 0..9 of table ARC_RM_180003M3_SC848_4MAN are used, else settings will be used from LoadProtocol 180003M3_SC848_4MAN Bits[14:10] = RFU Bit [9] = Enable the IIR filter. Bits[8:7] = MF_GAIN (this value will be applied to the SIGPR_RM_TECH register, applies as soon as the ARC is enabled) Bits[6:0] = DPC_SIGNAL_DETECT_TH_OVR_VAL (this value will be applied to the DGRM_RSSI register, applies as soon as the ARC is enabled)
1EE	RM_RX_ARC_3	15:0	Bit[15] 0: ARC settings always apply, bits 0...9 from the table ARC_RM_180003M3_SC848_4MAN are used 1: ARC settings during FDT, bits 0..9 of table ARC_RM_180003M3_SC848_4MAN are used, else settings will be used from LoadProtocol 180003M3_SC848_4MAN Bits[14:10] = RFU Bit [9] = Enable the IIR filter. Bits[8:7] = MF_GAIN (this value will be applied to the SIGPR_RM_TECH register, applies as soon as the ARC is enabled) Bits[6:0] = DPC_SIGNAL_DETECT_TH_OVR_VAL (this value will be applied to the DGRM_RSSI register, applies as soon as the ARC is enabled)

Table 259. ARC_RM_180003m3_SC848_4Man (address 01E8h) EEPROM configuration bit description...continued

Address (hex)	Function	Bit	Description
1EC	RM_RX_ARC_2	15:0	Bit[15] 0: ARC settings always apply, bits 0...9 from the table ARC_RM_180003M3_SC848_4MAN are used 1: ARC settings during FDT, bits 0..9 of table ARC_RM_180003M3_SC848_4MAN are used, else settings will be used from LoadProtocol 180003M3_SC848_4MAN Bits[14:10] = RFU Bit [9] = Enable the IIR filter. Bits[8:7] = MF_GAIN (this value will be applied to the SIGPR_RM_TECH register, applies as soon as the ARC is enabled) Bits[6:0] = DPC_SIGNAL_DETECT_TH_OVR_VAL (this value will be applied to the DGRM_RSSI register, applies as soon as the ARC is enabled)
1EA	RM_RX_ARC_1	15:0	Bit[15] 0: ARC settings always apply, bits 0...9 from the table ARC_RM_180003M3_SC848_4MAN are used 1: ARC settings during FDT, bits 0..9 of table ARC_RM_180003M3_SC848_4MAN are used, else settings will be used from LoadProtocol 180003M3_SC848_4MAN Bits[14:10] = RFU Bit [9] = Enable the IIR filter. Bits[8:7] = MF_GAIN (this value will be applied to the SIGPR_RM_TECH register, applies as soon as the ARC is enabled) Bits[6:0] = DPC_SIGNAL_DETECT_TH_OVR_VAL (this value will be applied to the DGRM_RSSI register, applies as soon as the ARC is enabled)
1E8	RM_RX_ARC_0	15:0	Bit[15] 0: ARC settings always apply 1: ARC settings applicable during FDT and DPC change Bit [14]: 1: ARC Enabled for this Tech and Baudrate. 0: ARC disabled for this Tech and Baudrate Bits[13:10] = RFU Bit [9] = Enable the IIR filter. Bits[8:7] = MF_GAIN (this value will be applied to the SIGPR_RM_TECH register, applies as soon as the ARC is enabled) Bits[6:0] = DPC_SIGNAL_DETECT_TH_OVR_VAL (this value will be applied to the DGRM_RSSI register, applies as soon as the ARC is enabled)

Note: The IIR settings define an all pass filter with approximately -10 dB gain. This can be used to limit the LMA sensitivity of the RX.

Note: Bit15 of all RM_RX_ARC_n is recommended to be "0" always.

9.24.132 ARC_RM_180003m3_SC848_2Man (01F2h)

This is the setting for type 180003m3_SC848_2Man.

Table 260. ARC_RM_180003m3_SC848_2Man (address 01F2h) EEPROM configuration bit description

Address (hex)	Function	Bit	Description
1FA	RM_RX_ARC_4	15:0	<p>Bit[15]</p> <p>0: ARC settings always apply, bits 0..9 from the table ARC_RM_180003M3_SC848_2MAN are used</p> <p>1: ARC settings during FDT, bits 0..9 of table ARC_RM_180003M3_SC848_2MAN are used, else settings will be used from LoadProtocol 180003M3_SC848_2MAN</p> <p>Bits[14:10] = RFU</p> <p>Bit [9] = Enable the IIR filter.</p> <p>Bits[8:7] = MF_GAIN (this value will be applied to the SIGPR_RM_TECH register, applies as soon as the ARC is enabled)</p> <p>Bits[6:0] = DPC_SIGNAL_DETECT_TH_OVR_VAL (this value will be applied to the DGRM_RSSI register, applies as soon as the ARC is enabled)</p>
1F8	RM_RX_ARC_3	15:0	<p>Bit[15]</p> <p>0: ARC settings always apply, bits 0..9 from the table ARC_RM_180003M3_SC848_2MAN are used</p> <p>1: ARC settings during FDT, bits 0..9 of table ARC_RM_180003M3_SC848_2MAN are used, else settings will be used from LoadProtocol 180003M3_SC848_2MAN</p> <p>Bits[14:10] = RFU</p> <p>Bit [9] = Enable the IIR filter.</p> <p>Bits[8:7] = MF_GAIN (this value will be applied to the SIGPR_RM_TECH register, applies as soon as the ARC is enabled)</p> <p>Bits[6:0] = DPC_SIGNAL_DETECT_TH_OVR_VAL (this value will be applied to the DGRM_RSSI register, applies as soon as the ARC is enabled)</p>
1F6	RM_RX_ARC_2	15:0	<p>Bit[15]</p> <p>0: ARC settings always apply, bits 0..9 from the table ARC_RM_180003M3_SC848_2MAN are used</p> <p>1: ARC settings during FDT, bits 0..9 of table ARC_RM_180003M3_SC848_2MAN are used, else settings will be used from LoadProtocol 180003M3_SC848_2MAN</p> <p>Bits[14:10] = RFU</p> <p>Bit [9] = Enable the IIR filter.</p> <p>Bit [9] = Enable the IIR filter.</p> <p>Bits[8:7] = MF_GAIN (this value will be applied to the SIGPR_RM_TECH register, applies as soon as the ARC is enabled)</p> <p>Bits[6:0] = DPC_SIGNAL_DETECT_TH_OVR_VAL (this value will be applied to the DGRM_RSSI register, applies as soon as the ARC is enabled)</p>
1F4	RM_RX_ARC_1	15:0	<p>Bit[15]</p> <p>0: ARC settings always apply, bits 0..9 from the table ARC_RM_180003M3_SC848_2MAN are used</p> <p>1: ARC settings during FDT, bits 0..9 of table ARC_RM_180003M3_SC848_2MAN are used, else settings will be used from LoadProtocol 180003M3_SC848_2MAN</p> <p>Bits[14:10] = RFU</p> <p>Bit [9] = Enable the IIR filter.</p> <p>Bits[8:7] = MF_GAIN (this value will be applied to the SIGPR_RM_TECH register, applies as soon as the ARC is enabled)</p> <p>Bits[6:0] = DPC_SIGNAL_DETECT_TH_OVR_VAL (this value will be applied to the DGRM_RSSI register, applies as soon as the ARC is enabled)</p>

Table 260. ARC_RM_180003m3_SC848_2Man (address 01F2h) EEPROM configuration bit description...continued

Address (hex)	Function	Bit	Description
1F2	RM_RX_ARC_0	15:0	Bit[15] 0: ARC settings always apply 1: ARC settings applicable during FDT and DPC change Bit [14]: 1: ARC Enabled for this Tech and Baudrate. 0: ARC disabled for this Tech and Baudrate Bits[13:10] = RFU Bit [9] = Enable the IIR filter. Bits[8:7] = MF_GAIN (this value will be applied to the SIGPR_RM_TECH register, applies as soon as the ARC is enabled) Bits[6:0] = DPC_SIGNAL_DETECT_TH_OVR_VAL (this value will be applied to the DGRM_RSSI register, applies as soon as the ARC is enabled)

Note: The IIR settings define an all pass filter with approximately -10 dB gain. This can be used to limit the LMA sensitivity of the RX.

Note: Bit15 of all RM_RX_ARC_n is recommended to be "0" always.

9.24.133 ARC_RM_AI106 (01FCh)

This is the setting for type AI106.

Table 261. ARC_RM_AI106 (address 01FCh) EEPROM configuration bit description

Address (hex)	Function	Bit	Description
204	RM_RX_ARC_4	15:0	Bit[15] 0: ARC settings always apply, bits 0...9 from the table ARC_RM_AI106 are used 1: ARC settings during FDT, bits 0..9 of table ARC_RM_AI106 are used, else settings will be used from LoadProtocol AI106 Bits[14:10] = RFU Bit [9] = Enable the IIR filter. Bits[8:7] = MF_GAIN (this value will be applied to the SIGPR_RM_TECH register, applies as soon as the ARC is enabled) Bits[6:0] = DPC_SIGNAL_DETECT_TH_OVR_VAL (this value will be applied to the DGRM_RSSI register, applies as soon as the ARC is enabled)
202	RM_RX_ARC_3	15:0	Bit[15] 0: ARC settings always apply, bits 0...9 from the table ARC_RM_AI106 are used 1: ARC settings during FDT, bits 0..9 of table ARC_RM_AI106 are used, else settings will be used from LoadProtocol AI106 Bits[14:10] = RFU Bit [9] = Enable the IIR filter. Bits[8:7] = MF_GAIN (this value will be applied to the SIGPR_RM_TECH register, applies as soon as the ARC is enabled) Bits[6:0] = DPC_SIGNAL_DETECT_TH_OVR_VAL (this value will be applied to the DGRM_RSSI register, applies as soon as the ARC is enabled)

Table 261. ARC_RM_AI106 (address 01FCh) EEPROM configuration bit description...continued

Address (hex)	Function	Bit	Description
200	RM_RX_ARC_2	15:0	Bit[15] 0: ARC settings always apply, bits 0...9 from the table ARC_RM_AI106 are used 1: ARC settings during FDT, bits 0..9 of table ARC_RM_AI106 are used, else settings will be used from LoadProtocol AI106 Bits[14:10] = RFU Bit [9] = Enable the IIR filter. Bits[8:7] = MF_GAIN (this value will be applied to the SIGPR_RM_TECH register, applies as soon as the ARC is enabled) Bits[6:0] = DPC_SIGNAL_DETECT_TH_OVR_VAL (this value will be applied to the DGRM_RSSI register, applies as soon as the ARC is enabled)
1FE	RM_RX_ARC_1	15:0	Bit[15] 0: ARC settings always apply, bits 0...9 from the table ARC_RM_AI106 are used 1: ARC settings during FDT, bits 0..9 of table ARC_RM_AI106 are used, else settings will be used from LoadProtocol AI106 Bits[14:10] = RFU Bit [9] = Enable the IIR filter. Bits[8:7] = MF_GAIN (this value will be applied to the SIGPR_RM_TECH register, applies as soon as the ARC is enabled) Bits[6:0] = DPC_SIGNAL_DETECT_TH_OVR_VAL (this value will be applied to the DGRM_RSSI register, applies as soon as the ARC is enabled)
1FC	RM_RX_ARC_0	15:0	Bit[15] 0: ARC settings always apply 1: ARC settings applicable during FDT and DPC change Bit [14]: 1: ARC Enabled for this Tech and Baudrate. 0: ARC disabled for this Tech and Baudrate Bits[13:10] = RFU Bit [9] = Enable the IIR filter. Bits[8:7] = MF_GAIN (this value will be applied to the SIGPR_RM_TECH register, applies as soon as the ARC is enabled) Bits[6:0] = DPC_SIGNAL_DETECT_TH_OVR_VAL (this value will be applied to the DGRM_RSSI register, applies as soon as the ARC is enabled)

Note: The IIR settings define an all pass filter with approximately -10 dB gain. This can be used to limit the LMA sensitivity of the RX.

Note: Bit15 of all RM_RX_ARC_n is recommended to be "0" always.

9.24.134 ARC_RM_AI212 (0206h)

This is the setting for type AI212.

Table 262. ARC_RM_AI212 (0206h) EEPROM configuration bit description

Address (hex)	Function	Bit	Description
20E	RM_RX_ARC_4	15:0	Bit[15] 0: ARC settings always apply, bits 0..9 from the table ARC_RM_AI212 are used 1: ARC settings during FDT, bits 0..9 of table ARC_RM_AI212 are used, else settings will be used from LoadProtocol AI212 Bits[14:10] = RFU Bit [9] = Enable the IIR filter. Bits[8:7] = MF_GAIN (this value will be applied to the SIGPR_RM_TECH register, applies as soon as the ARC is enabled) Bits[6:0] = DPC_SIGNAL_DETECT_TH_OVR_VAL (this value will be applied to the DGRM_RSSI register, applies as soon as the ARC is enabled)
20C	RM_RX_ARC_3	15:0	Bit[15] 0: ARC settings always apply, bits 0..9 from the table ARC_RM_AI212 are used 1: ARC settings during FDT, bits 0..9 of table ARC_RM_AI212 are used, else settings will be used from LoadProtocol AI212 Bits[14:10] = RFU Bit [9] = Enable the IIR filter. Bits[8:7] = MF_GAIN (this value will be applied to the SIGPR_RM_TECH register, applies as soon as the ARC is enabled) Bits[6:0] = DPC_SIGNAL_DETECT_TH_OVR_VAL (this value will be applied to the DGRM_RSSI register, applies as soon as the ARC is enabled)
20A	RM_RX_ARC_2	15:0	Bit[15] 0: ARC settings always apply, bits 0..9 from the table ARC_RM_AI212 are used 1: ARC settings during FDT, bits 0..9 of table ARC_RM_AI212 are used, else settings will be used from LoadProtocol AI212 Bits[14:10] = RFU Bit [9] = Enable the IIR filter. Bits[8:7] = MF_GAIN (this value will be applied to the SIGPR_RM_TECH register, applies as soon as the ARC is enabled) Bits[6:0] = DPC_SIGNAL_DETECT_TH_OVR_VAL (this value will be applied to the DGRM_RSSI register, applies as soon as the ARC is enabled)
208	RM_RX_ARC_1	15:0	Bit[15] 0: ARC settings always apply, bits 0..9 from the table ARC_RM_AI212 are used 1: ARC settings during FDT, bits 0..9 of table ARC_RM_AI212 are used, else settings will be used from LoadProtocol AI212 Bits[14:10] = RFU Bit [9] = Enable the IIR filter. Bits[8:7] = MF_GAIN (this value will be applied to the SIGPR_RM_TECH register, applies as soon as the ARC is enabled) Bits[6:0] = DPC_SIGNAL_DETECT_TH_OVR_VAL (this value will be applied to the DGRM_RSSI register, applies as soon as the ARC is enabled)

Table 262. ARC_RM_AI212 (0206h) EEPROM configuration bit description...continued

Address (hex)	Function	Bit	Description
206	RM_RX_ARC_0	15:0	Bit[15] 0: ARC settings always apply 1: ARC settings applicable during FDT and DPC change Bit [14]: 1: ARC Enabled for this Tech and Baudrate. 0: ARC disabled for this Tech and Baudrate Bits[13:10] = RFU Bit [9] = Enable the IIR filter. Bits[8:7] = MF_GAIN (this value will be applied to the SIGPR_RM_TECH register, applies as soon as the ARC is enabled) Bits[6:0] = DPC_SIGNAL_DETECT_TH_OVR_VAL (this value will be applied to the DGRM_RSSI register, applies as soon as the ARC is enabled)

Note: The IIR settings define an all pass filter with approximately -10 dB gain. This can be used to limit the LMA sensitivity of the RX.

Note: Bit15 of all RM_RX_ARC_n is recommended to be "0" always.

9.24.135 ARC_RM_AI424 (0210h)

This is the setting for type AI424.

Table 263. ARC_RM_AI424 (0210h) EEPROM configuration bit description

Address (hex)	Function	Bit	Description
218	RM_RX_ARC_4	15:0	Bit[15] 0: ARC settings always apply, bits 0...9 from the table ARC_RM_AI424 are used 1: ARC settings during FDT, bits 0..9 of table ARC_RM_AI424 are used, else settings will be used from LoadProtocol AI424 Bits[14:10] = RFU Bit [9] = Enable the IIR filter. Bits[8:7] = MF_GAIN (this value will be applied to the SIGPR_RM_TECH register, applies as soon as the ARC is enabled) Bits[6:0] = DPC_SIGNAL_DETECT_TH_OVR_VAL (this value will be applied to the DGRM_RSSI register, applies as soon as the ARC is enabled)
216	RM_RX_ARC_3	15:0	Bit[15] 0: ARC settings always apply, bits 0...9 from the table ARC_RM_AI424 are used 1: ARC settings during FDT, bits 0..9 of table ARC_RM_AI424 are used, else settings will be used from LoadProtocol AI424 Bits[14:10] = RFU Bit [9] = Enable the IIR filter. Bits[8:7] = MF_GAIN (this value will be applied to the SIGPR_RM_TECH register, applies as soon as the ARC is enabled) Bits[6:0] = DPC_SIGNAL_DETECT_TH_OVR_VAL (this value will be applied to the DGRM_RSSI register, applies as soon as the ARC is enabled)

Table 263. ARC_RM_AI424 (0210h) EEPROM configuration bit description...continued

Address (hex)	Function	Bit	Description
214	RM_RX_ARC_2	15:0	Bit[15] 0: ARC settings always apply, bits 0...9 from the table ARC_RM_AI424 are used 1: ARC settings during FDT, bits 0..9 of table ARC_RM_AI424 are used, else settings will be used from LoadProtocol AI424 Bits[14:10] = RFU Bit [9] = Enable the IIR filter. Bits[8:7] = MF_GAIN (this value will be applied to the SIGPR_RM_TECH register, applies as soon as the ARC is enabled) Bits[6:0] = DPC_SIGNAL_DETECT_TH_OVR_VAL (this value will be applied to the DGRM_RSSI register, applies as soon as the ARC is enabled)
212	RM_RX_ARC_1	15:0	Bit[15] 0: ARC settings always apply, bits 0...9 from the table ARC_RM_AI424 are used 1: ARC settings during FDT, bits 0..9 of table ARC_RM_AI424 are used, else settings will be used from LoadProtocol AI424 Bits[14:10] = RFU Bit [9] = Enable the IIR filter. Bits[8:7] = MF_GAIN (this value will be applied to the SIGPR_RM_TECH register, applies as soon as the ARC is enabled) Bits[6:0] = DPC_SIGNAL_DETECT_TH_OVR_VAL (this value will be applied to the DGRM_RSSI register, applies as soon as the ARC is enabled)
210	RM_RX_ARC_0	15:0	Bit[15] 0: ARC settings always apply 1: ARC settings applicable during FDT and DPC change Bit [14]: 1: ARC Enabled for this Tech and Baudrate. 0: ARC disabled for this Tech and Baudrate Bits[13:10] = RFU Bit [9] = Enable the IIR filter. Bits[8:7] = MF_GAIN (this value will be applied to the SIGPR_RM_TECH register, applies as soon as the ARC is enabled) Bits[6:0] = DPC_SIGNAL_DETECT_TH_OVR_VAL (this value will be applied to the DGRM_RSSI register, applies as soon as the ARC is enabled)

Note: The IIR settings define an all pass filter with approximately -10 dB gain. This can be used to limit the LMA sensitivity of the RX.

Note: Bit15 of all RM_RX_ARC_n is recommended to be "0" always.

9.24.136 RF_DEBOUNCE_TIMEOUT (02B2h)

Table 264. RF_DEBOUNCE_TIMEOUT (address 02B2h) EEPROM configuration bit description

Address (hex)	Function	Bit	Description
2B2	DEBOUNCE_TIMEOUT	7:0	Timeout used after the RF detection during the AUTOCOLL to detect if there is a glitch or continuous RF Value is entered in micro seconds, each bit represents 1 micro second

9.24.137 SENSE_RES (02B3h)**Table 265. SENSE_RES (address 02B3) EEPROM configuration bit description**

Address (hex)	Function	Bit	Description
2B3	AUTOCOLL configuration	16:0	ATQA in order byte 0, byte 1
		16:8	Byte1
		7:0	Byte0

9.24.138 NFC_ID1 (02B5h)**Table 266. SIGNAL_SCALING_CONFIG (address 2B5h) EEPROM configuration bit description**

Address (hex)	Function	Bit	Description
2B5	AUTOCOLL configuration		If Random UID is disabled (EEPROM address 0x2CB), the content of these addresses is used to generate a Fixed UID. The order is byte 0, Byte 1, Byte 2; Byte3 - which is the first NFCID1 byte - is fixed to 08h, the check byte is calculated automatically
		23:16	Byte2
		15:8	Byte1:
		7:0	Byte0:

9.24.139 SEL_RES (02B8h)**Table 267. SEL_RES (address 2B8h) EEPROM configuration bit description**

Address (hex)	Function	Bit	Description
2B8	AUTOCOLL configuration	7:0	Response to Select: SAK

9.24.140 FELICA_POLL_RES (02B9h)

The FeliCa response is configured by 18 bytes.

Table 268. FELICA_POLL_RES (address 02B9) EEPROM configuration bit description

Address (hex)	Function	Bit	Description
2B9	AUTOCOLL configuration	15:0	FeliCa Polling response (2 bytes (shall be 01h, FEh) + 6 bytes NFCID2 + 8 bytes Pad + 2 bytes system code)
		47:0	NFCID2
		63:0	PAD
		15:0	system code

9.24.141 RANDOM_UID_ENABLE (02CBh)

Table 269. RANDOM_UID_ENABLE (address 2CBh) EEPROM configuration bit description

Address (hex)	Function	Bit	Description
2CB	RFU	7:1	-
	Random UID Enable	0	0: Use UID stored in EEPROM 1: Randomly generate the UID in which the first byte is fixed and the remaining 3 bytes are random A new random number is generated after each RF-OFF to RF-ON.

9.24.142 MFC_AUTH_TIMEOUT (02CCh)

Table 270. MFC_AUTH_TIMEOUT (address 2CCh) EEPROM configuration bit description

Address (hex)	Function	Bit	Description
2CC	RFU	15:0	Timeout value in micro seconds used for Auth1 & Auth2 stages during MIFARE Classic Authenticate

9.24.143 RSSI_TIMER (02DAh)

Configuration for Card Emulation mode only.

Table 271. RSSI_TIMER (address 2DAh) EEPROM configuration bit description

Address (hex)	Function	Bit	Description
2DA	RSSI_TIMER	15:0	Default: 423

9.24.144 RSSI_TIMER_FIRST_PERIOD (02DCh)

Table 272. RSSI_TIMER_FIRST_PERIOD (address 2DCh) EEPROM configuration bit description

Address (hex)	Function	Bit	Description
2DC	RSSI	15:0	First period duration after Rffield ON. Unit is 128/fc (106 kHz) if set to 0 it means that feature is not used 0D2 => ~2 ms

9.24.145 RSSI_CTRL_00_AB (02DEh)

Table 273. RSSI_CTRL_00_AB (address 2DEh) EEPROM configuration bit description

Address (hex)	Function	Bit	Description
2DE	RSSI	7:6	Bits [6:7] = RFU
		5:0	Bits [0:5] = (APC_ID_REF_AB) ID of APC_TX entry that is equiv to RSSI = 0 (for Type AB)

9.24.146 RSSI_NB_ENTRIES_AB (02DFh)

Table 274. RSSI_NB_ENTRIES_AB (address 2DFh) EEPROM configuration bit description

Address (hex)	Function	Bit	Description
2DF	RSSI	7:5	RFU
		4:0	For Initial RF ON, CEA and CEB Number of entries in RSSI lookup table (it refers to dwRssiEntryAB_01 to dwRssiEntryAB_X);

9.24.147 RSSI_THRESHOLD_PHASE_TABLE (02E0h)

Table 275. RSSI_THRESHOLD_PHASE_TABLE (address 2E0h) EEPROM configuration bit description

Address (hex)	Function	Bit	Description
2E0	wRssiThresholdF_01	15:0	bit[0:12] - RSSI Value bit[13:15] - RFU Note: dwRssiEntryAB_00 = 0 (not in EEPROM) Signed phase compensation with 1/4 degree resolution: 16 bits signed value (using complement of 2)
2E2	ArbPhaseF_01	15:0	wArbPhaseF_xx: Signed phase compensation with 1/4 degree resolution: 16 bits signed value (using complement of 2)
	RssiThresholdF_02	15:0	
	ArbPhaseF_02	15:0	
	RssiThresholdF_03	15:0	
	ArbPhaseF_03	15:0	
	RssiThresholdF_04	15:0	
	ArbPhaseF_04	15:0	
	RssiThresholdF_05	15:0	
	ArbPhaseF_05	15:0	
	RssiThresholdF_06	15:0	
	ArbPhaseF_06	15:0	
	RssiThresholdF_07	15:0	
	ArbPhaseF_07	15:0	
	RssiThresholdF_08	15:0	
	ArbPhaseF_08	15:0	
	RssiThresholdF_09	15:0	
	ArbPhaseF_09	15:0	
	RssiThresholdF_0A	15:0	
	ArbPhaseF_0A	15:0	
	RssiThresholdF_0B	15:0	
	ArbPhaseF_0B	15:0	
	RssiThresholdF_0C	15:0	

Table 275. RSSI_THRESHOLD_PHASE_TABLE (address 2E0h) EEPROM configuration bit description...continued

Address (hex)	Function	Bit	Description
	ArbPhaseF_0C	15:0	
	RssiThresholdF_0D	15:0	
	ArbPhaseF_0D	15:0	
	RssiThresholdF_0E	15:0	
	ArbPhaseF_0E	15:0	
	RssiThresholdF_0F	15:0	
	ArbPhaseF_0F	15:0	
	RssiThresholdF_10	15:0	
	ArbPhaseF_10	15:0	
	RssiThresholdF_11	15:0	
	ArbPhaseF_11	15:0	
	RssiThresholdF_12	15:0	
	ArbPhaseF_12	15:0	
	RssiThresholdF_13	15:0	
	ArbPhaseF_13	15:0	
	RssiThresholdF_14	15:0	
	ArbPhaseF_14	15:0	
	RssiThresholdF_15	15:0	
	ArbPhaseF_15	15:0	
	RssiThresholdF_16	15:0	
	ArbPhaseF_16	15:0	
	RssiThresholdF_17	15:0	
	ArbPhaseF_17	15:0	
	RssiThresholdF_18	15:0	
	ArbPhaseF_18	15:0	

9.24.148 TX_PARAM_ENTRY_TABLE (03A2h)

Table 276. TX_PARAM_ENTRY_TABLE (address 3A2h) EEPROM configuration bit description

Address (hex)	Function	Bit	Description
3A2	TxParamEntry_00_ID	7	bit[7] Driver count (CLIF_TX_CONTROL_REG.TX_ALM_TYPE_SELECT): 0 - Dual driver, 1 - Single driver
		6	BPSK mode (CLIF_TX_CONTROL_REG.TX_ALM_BPSK_ENABLE): 0 - Disabled, 1 - Enabled
		5:0	ID

Table 276. TX_PARAM_ENTRY_TABLE (address 3A2h) EEPROM configuration bit description...continued

Address (hex)	Function	Bit	Description
	bTxParamEntry_00_Tx1	7:6	RFU
		5:0	PMU VDDPA setting: $VDDPA(v) = (val*10)+1,5$ 0 = 1.50 V ... 2Ah = 5.70 V
	bTxParamEntry_00_Tx2	7:0	Scaling factor for TX1 and TX2
3A5	TxParamEntry_01_ID	7	bit[7] Driver count (CLIF_TX_CONTROL_REG.TX_ALM_TYPE_SELECT): 0 - Dual driver, 1 - Single driver
		6	BPSK mode (CLIF_TX_CONTROL_REG.TX_ALM_BPSK_ENABLE): 0 - Disabled, 1 - Enabled
		5:0	ID
	bTxParamEntry_01_Tx1	7:6	RFU
		5:0	PMU VDDPA setting: $VDDPA(v) = (val*10)+1,5$ 0 = 1.50 V ... 2Ah = 5.70 V
	bTxParamEntry_01_Tx2	7:0	Scaling factor for TX1 and TX2
3A8	TxParamEntry_02_ID	7	bit[7] Driver count (CLIF_TX_CONTROL_REG.TX_ALM_TYPE_SELECT): 0 - Dual driver, 1 - Single driver
		6	BPSK mode (CLIF_TX_CONTROL_REG.TX_ALM_BPSK_ENABLE): 0 - Disabled, 1 - Enabled
		5:0	ID
	bTxParamEntry_02_Tx1	7:6	RFU
		5:0	PMU VDDPA setting: $VDDPA(v) = (val*10)+1,5$ 0 = 1.50 V ... 2Ah = 5.70 V
	bTxParamEntry_02_Tx2	7:0	Scaling factor for TX1 and TX2
3AB	TxParamEntry_03_ID	7	bit[7] Driver count (CLIF_TX_CONTROL_REG.TX_ALM_TYPE_SELECT): 0 - Dual driver, 1 - Single driver
		6	BPSK mode (CLIF_TX_CONTROL_REG.TX_ALM_BPSK_ENABLE): 0 - Disabled, 1 - Enabled
		5:0	ID
	bTxParamEntry_03_Tx1	7:6	RFU
		5:0	PMU VDDPA setting: $VDDPA(v) = (val*10)+1,5$ 0 = 1.50 V ... 2Ah = 5.70 V
	bTxParamEntry_03_Tx2	7:0	Scaling factor for TX1 and TX2
3AE	TxParamEntry_04_ID	7	bit[7] Driver count (CLIF_TX_CONTROL_REG.TX_ALM_TYPE_SELECT): 0 - Dual driver, 1 - Single driver
		6	BPSK mode (CLIF_TX_CONTROL_REG.TX_ALM_BPSK_ENABLE): 0 - Disabled, 1 - Enabled
		5:0	ID

Table 276. TX_PARAM_ENTRY_TABLE (address 3A2h) EEPROM configuration bit description...continued

Address (hex)	Function	Bit	Description
	bTxParamEntry_04_Tx1	7:6	RFU
		5:0	PMU VDDPA setting: $VDDPA(v) = (val*10)+1,5$ 0 = 1.50 V ... 2Ah = 5.70 V
	bTxParamEntry_04_Tx2	7:0	Scaling factor for TX1 and TX2
3B1	TxParamEntry_05_ID	7	bit[7] Driver count (CLIF_TX_CONTROL_REG.TX_ALM_TYPE_SELECT): 0 - Dual driver, 1 - Single driver
		6	BPSK mode (CLIF_TX_CONTROL_REG.TX_ALM_BPSK_ENABLE): 0 - Disabled, 1 - Enabled
		5:0	ID
	bTxParamEntry_05_Tx1	7:6	RFU
		5:0	PMU VDDPA setting: $VDDPA(v) = (val*10)+1,5$ 0 = 1.50 V ... 2Ah = 5.70 V
	bTxParamEntry_05_Tx2	7:0	Scaling factor for TX1 and TX2
3B4	TxParamEntry_06_ID	7	bit[7] Driver count (CLIF_TX_CONTROL_REG.TX_ALM_TYPE_SELECT): 0 - Dual driver, 1 - Single driver
		6	BPSK mode (CLIF_TX_CONTROL_REG.TX_ALM_BPSK_ENABLE): 0 - Disabled, 1 - Enabled
		5:0	ID
	bTxParamEntry_06_Tx1	7:6	RFU
		5:0	PMU VDDPA setting: $VDDPA(v) = (val*10)+1,5$ 0 = 1.50 V ... 2Ah = 5.70 V
	bTxParamEntry_06_Tx2	7:0	Scaling factor for TX1 and TX2
3B7	TxParamEntry_07_ID	7	bit[7] Driver count (CLIF_TX_CONTROL_REG.TX_ALM_TYPE_SELECT): 0 - Dual driver, 1 - Single driver
		6	BPSK mode (CLIF_TX_CONTROL_REG.TX_ALM_BPSK_ENABLE): 0 - Disabled, 1 - Enabled
		5:0	ID
	bTxParamEntry_07_Tx1	7:6	RFU
		5:0	PMU VDDPA setting: $VDDPA(v) = (val*10)+1,5$ 0 = 1.50 V ... 2Ah = 5.70 V
	bTxParamEntry_07_Tx2	7:0	Scaling factor for TX1 and TX2
3BA	TxParamEntry_08_ID	7	bit[7] Driver count (CLIF_TX_CONTROL_REG.TX_ALM_TYPE_SELECT): 0 - Dual driver, 1 - Single driver
		6	BPSK mode (CLIF_TX_CONTROL_REG.TX_ALM_BPSK_ENABLE): 0 - Disabled, 1 - Enabled
		5:0	ID

Table 276. TX_PARAM_ENTRY_TABLE (address 3A2h) EEPROM configuration bit description...continued

Address (hex)	Function	Bit	Description
	bTxParamEntry_08_Tx1	7:6	RFU
		5:0	PMU VDDPA setting: $VDDPA(v) = (val*10)+1,5$ 0 = 1.50 V ... 2Ah = 5.70 V
	bTxParamEntry_08_Tx2	7:0	Scaling factor for TX1 and TX2
3BD	TxParamEntry_09_ID	7	bit[7] Driver count (CLIF_TX_CONTROL_REG.TX_ALM_TYPE_SELECT): 0 - Dual driver, 1 - Single driver
		6	BPSK mode (CLIF_TX_CONTROL_REG.TX_ALM_BPSK_ENABLE): 0 - Disabled, 1 - Enabled
		5:0	ID
	bTxParamEntry_09_Tx1	7:6	RFU
		5:0	PMU VDDPA setting: $VDDPA(v) = (val*10)+1,5$ 0 = 1.50 V ... 2Ah = 5.70 V
	bTxParamEntry_09_Tx2	7:0	Scaling factor for TX1 and TX2
3C1	TxParamEntry_0A_ID	7	bit[7] Driver count (CLIF_TX_CONTROL_REG.TX_ALM_TYPE_SELECT): 0 - Dual driver, 1 - Single driver
		6	BPSK mode (CLIF_TX_CONTROL_REG.TX_ALM_BPSK_ENABLE): 0 - Disabled, 1 - Enabled
		5:0	ID
	bTxParamEntry_0A_Tx1	7:6	RFU
		5:0	PMU VDDPA setting: $VDDPA(v) = (val*10)+1,5$ 0 = 1.50 V ... 2Ah = 5.70 V
	bTxParamEntry_0A_Tx2	7:0	Scaling factor for TX1 and TX2
3C3	TxParamEntry_0B_ID	7	bit[7] Driver count (CLIF_TX_CONTROL_REG.TX_ALM_TYPE_SELECT): 0 - Dual driver, 1 - Single driver
		6	BPSK mode (CLIF_TX_CONTROL_REG.TX_ALM_BPSK_ENABLE): 0 - Disabled, 1 - Enabled
		5:0	ID
	bTxParamEntry_0B_Tx1	7:6	RFU
		5:0	PMU VDDPA setting: $VDDPA(v) = (val*10)+1,5$ 0 = 1.50 V ... 2Ah = 5.70 V
	bTxParamEntry_0B_Tx2	7:0	Scaling factor for TX1 and TX2

9.24.149 LPCD_AVG_SAMPLES (0492h)

Configuration for the Switch mode LPCD

Table 277. LPCD_AVG_SAMPLES (address 0492h) EEPROM configuration bit description

Address (hex)	Function	Bit	Description
492	LPCD setting	7	Defining how many samples of the I and Q values are used for the averaging. Average of samples in power of 2 0->1 sample 1->2 samples 2->4 samples 3->8 samples 4->16 samples 5-> 32 samples

9.24.150 LPCD_RSSI_TARGET (0494h)

Table 278. LPCD_RSSI_TARGET (address 0494h) EEPROM configuration bit description

Address (hex)	Function	Bit	Description
494	LPCD setting	7	Value to be set in register DGRM_RSSI_REG_DGRM_RSSI_TARGET Typically the same values from the Type A106 LOAD_RF_CONFIGURATION(0x0D) (DGRM_RSSI register) are used

9.24.151 LPCD_RSSI_HYST (0496h)

Table 279. LPCD_RSSI_HYST (address 0496h) EEPROM configuration bit description

Address (hex)	Function	Bit	Description
496	LPCD setting	7	Value to be set in CLIF_DGRM_RSSI_REG_DGRM_RSSI_HYST Typically the same values from the Type A106 LOAD_RF_CONFIGURATION(0x0D) (DGRM_RSSI register) are used

9.24.152 LPCD_CONFIG (0497h)

Table 280. LPCD_CONFIG (address 0497h) EEPROM configuration register bit description

Address (hex)	Function	Bit	Description
49B	RFU	15:6	-
		5	Immediate RF OFF before TXLDO shutdown to save power 0 - Disable 1 - Enable
		4	VDDPA fast discharge 0 - Disable 1 - Enable
		3	TX Drivers 0 - Enable Single driver 1 - Enable both drivers
	Acquisition channels:	2:0	0:1 = RFU 2 = Magnitude 3 = I and Q 4 =M, I and Q 5:7 = RFU

9.24.153 LPCD_THRESHOLD_COARSE (049Ah)

Table 281. LPCD_THRESHOLD_COARSE (address 049Ah) EEPROM configuration bit description

Address (hex)	Function	Bit	Description
49E	LPCD Q channel threshold	31:16	ADC LSB granularity of threshold depends on avg_samples_meas value 5: unit 1/32; 4: unit 1/16; 3: unit 1/8; 2: unit 1/4; 1: unit 1/2; 0: unit 1
	LPCD I channel threshold	0:15	ADC LSB granularity of threshold depends on avg_samples_meas value 5: unit 1/32; 4: unit 1/16; 3: unit 1/8; 2: unit 1/4; 1: unit 1/2; 0: unit 1

Note: If the difference between the measured value and the reference is greater than the threshold on either channels, then a card is detected.

9.24.154 LPCD_VDDPA (04B5h)

Table 282. LPCD_VDDPA (address 04B5h) EEPROM configuration bit description

Address (hex)	Function	Bit	Description
4B5	VDDPA voltage during LPCD when DC-DC (internal or external) or external power source is used to feed TXLDO	7:0	TXLDO output voltage: 0x00: 1V50 0x01: 1V60 0x02: 1V70 0x03: 1V80 0x04: 1V90 0x05: 2V00 0x06: 2V10 0x07: 2V20 0x08: 2V30 0x09: 2V40 0x0A: 2V50 0x0B: 2V60 0x0C: 2V70 0x0D: 2V80 0x0E: 2V90 0x0F: 3V00 0x10: 3V10 0x11: 3V20 0x12: 3V30 0x13: 3V40 0x14: 3V50 0x15: 3V60 0x16: 3V70 0x17: 3V80 0x18: 3V90 0x19: 4V00 0x1A: 4V10 0x1B: 4V20 0x1C: 4V30 0x1D: 4V40 0x1E: 4V50 0x1F: 4V60 0x20: 4V70 0x21: 4V80 0x22: 4V90 0x23: 5V00 0x24: 5V10 0x25: 5V20 0x26: 5V30 0x27: 5V40 0x28: 5V50 0x29: 5V60 0x2A: 5V70

9.24.155 ULPCD_VDDPA_CTRL (04BFh)

Table 283. ULPCD_VDDPA_CTRL (address 4BFh) EEPROM configuration bit description

Address (hex)	Function	Bit	Description
	RFU	15:9	-
	LDO_VDDPA_VOUT_SEL	3-8	TXLDO output voltage during ULPCD polling VDDPA_1V50 /* 0x00 */ VDDPA_1V60 /* 0x01 */ VDDPA_1V70 /* 0x02 */ VDDPA_1V80 /* 0x03 */ VDDPA_1V90 /* 0x04 */ VDDPA_2V00 /* 0x05 */ VDDPA_2V10 /* 0x06 */ VDDPA_2V20 /* 0x07 */ VDDPA_2V30 /* 0x08 */ VDDPA_2V40 /* 0x09 */ VDDPA_2V50 /* 0x0A */ VDDPA_2V60 /* 0x0B */ VDDPA_2V70 /* 0x0C */ VDDPA_2V80 /* 0x0D */ VDDPA_2V90 /* 0x0E */ VDDPA_3V00 /* 0x0F */ VDDPA_3V10 /* 0x10 */ VDDPA_3V20 /* 0x11 */ VDDPA_3V30 /* 0x12 */ VDDPA_3V40 /* 0x13 */ VDDPA_3V50 /* 0x14 */ VDDPA_3V60 /* 0x15 */ VDDPA_3V70 /* 0x16 */ VDDPA_3V80 /* 0x17 */ VDDPA_3V90 /* 0x18 */ VDDPA_4V00 /* 0x19 */ VDDPA_4V10 /* 0x1A */ VDDPA_4V20 /* 0x1B */ VDDPA_4V30 /* 0x1C */ VDDPA_4V40 /* 0x1D */ VDDPA_4V50 /* 0x1E */ VDDPA_4V60 /* 0x1F */ VDDPA_4V70 /* 0x20 */ VDDPA_4V80 /* 0x21 */ VDDPA_4V90 /* 0x22 */ VDDPA_5V00 /* 0x23 */ VDDPA_5V10 /* 0x24 */ VDDPA_5V20 /* 0x25 */ VDDPA_5V30 /* 0x26 */ VDDPA_5V40 /* 0x27 */ VDDPA_5V50 /* 0x28 */ VDDPA_5V60 /* 0x29 */ VDDPA_5V70 /* 0x2A */

Table 283. ULPCD_VDDPA_CTRL (address 4BFh) EEPROM configuration bit description...continued

Address (hex)	Function	Bit	Description
4BF	RFU	2:0	-

9.24.156 ULPCD_TIMING_CTRL (04C2h)

Table 284. ULPCD_TIMING_CTRL (address 4C2h) EEPROM configuration bit description

Address (hex)	Function	Bit	Description
4C2	RFON_GUARD_TIME	7:4	RFON guard time: $(\text{RFON_GUARD_TIME} + 2) * \text{LFO-Freq}$ (380 kHz) Guard time: Time between RF-ON and first sampling of data
	RFU	3:0	-

9.24.157 ULPCD_VOLTAGE_CTRL (04C6h)

Table 285. ULPCD_VOLTAGE_CTRL (address 4C6h) EEPROM configuration bit description

Address (hex)	Function	Bit	Description
4C6	ULPCD configuration	7:5	RFU
		4:2	RFU
		1	TX_SUPPLY by VUP_TX 0: VUP externally supplied (2.8 V to 6.0 V) 1: VUP supplied by PN5190B1 itself (pin VUP_TX connected to VBAT/VBATPWR)
		0	RFU

9.24.158 ULPCD_RSSI_GUARD_TIME (04C9h)

Table 286. ULPCD_RSSI_GUARD_TIME (address 4C9h) EEPROM configuration bit description

Address (hex)	Function	Bit	Description
4C9	ULPCD RSSI sampling guard time	15	RFU
		14:0	This is the time between consecutive RSSI samples: Range: 0 - 127 in micro seconds

9.24.159 ULPCD_RSSI_SAMPLE_CFG (04CAh)

Table 287. ULPCD_RSSI_SAMPLE_CFG (address 4CAh) EEPROM configuration bit description

Address (hex)	Function	Bit	Description
4CA	ULPCD configuration	15:0	Number of RSSI Samples which are internally averaged: 0: 4 samples, 1: 8 samples 2: 16 samples 3: 32 samples

9.24.160 ULPCD_THRESH_LVL(04CBh)

Table 288. ULPCD_THRESH_LVL (address 4CBh) EEPROM configuration bit description

Address (hex)	Function	Bit	Description
4CB	ULPCD configuration	15:0	RSSI Threshold level Range 0 - 31 If the difference between the measured RSSI value and the reference (which is derived during calibration) is greater than the threshold, then a card is detected.

9.24.161 ULPCD_GPIO3 (04CCh)

Table 289. ULPCD_GPIO3 (address 4CCh) EEPROM configuration bit description

Address (hex)	Function	Bit	Description
4CC	RFU	7:1	-
4CC	ULPCD GPIO3 configuration	0	GPIO3 abort polarity configuration. If PN5190B1 is using the ULPCD, GPIO3 cannot be used for any other purpose than aborting the ULPCD. 1: high-level abort ULPCD 0: low-level abort ULPCD

9.24.162 TXIRQ_GuardTime (0559h)

Table 290. FELICA_POLL_RES (address 0559) EEPROM configuration bit description

Address (hex)	Function	Bit	Description
559	TXIRQ_GuardTime	31:0	0 - Disabled 0x1-0xFFFF (Enabled - 1 unit corresponds to 1 us) Maximum timeout of 1.048 s

9.24.163 FDT_default_val (055Dh)

Table 291. FDT_default_val (address 055D) EEPROM configuration bit description

Address (hex)	Function	Bit	Description
55D	FDT_default_val	31:0	0x00 - Disabled others - enabled (1 unit is 18.86us) Default fixed to 5.5 secs

9.24.164 RXIRQ_GuardTime (0561h)

Table 292. RXIRQ_GuardTime (address 0561h) EEPROM configuration bit description

Address (hex)	Function	Bit	Description
561	RXIRQ_GuardTime	31:0	0x00 Disabled 0x1-0xFFFF (Enabled - 1 unit corresponds to 1 us) Maximum timeout of 1.048 s Default value = 0xF4240 (1 s)

9.24.165 NFCLD_RFLD_Valid (006D3h)

Table 293. NFCLD_RFLD_Valid (address 06D3h) EEPROM configuration register bit description

Address (hex)	Function	Bit	Description
6D3	RFU	7:1	-
	RFLD_CALIBRATE	0	This bit allows to calibrate the RFLD / NFCLD. This calibration is required only once in the lifetime of the chip for increased RFLD / NFCLD accuracy, independent from the value of this bit (0 or 1). Clearing this bit (0) will calibrate the RFLD /RFLD during the next boot-up, precondition for the proper calibration is an unloaded condition and no external field applied. After calibration this bit is set (1) and indicates that the RFLD /RFLD Threshold is a valid data.

9.24.166 CurrentSensorTrimConfig (0ABCh)

Table 294. CurrentSensorTrimConfig (address 0CACH) EEPROM configuration bit description

Address (hex)	Function	Bit	Description
ABC	RFU	7:1	-
	Current_Sensor_Calib_Bypass	0	1: current sensor calibration offset is used by DPC; 0: Current sensor calibration offset is bypassed by DPC

Note: The default value should only be modified for debug purpose.

9.24.167 CORRECTION_ENTRY_TABLE (0BDAh)

Table 295. CORRECTION_ENTRY_TABLE (address 0BDAh) EEPROM configuration bit description

Address (hex)	Function	Bit	Description
0BDA	sCorrection_Entry0	15:0	The correction that is applied when lookup table based shaping with scaling is enabled. Range is -128 to +127, sCorrection_Entry0 corresponds to correction applied at VDDPA = 1V5, Correction_Entry42 corresponds to correction applied at VDDPA = 5V7 For each entry: BYTE 0: Bits[7:0] = define the correction which is applied for ASK100 BYTE 1: Bits[15:8] = define the correction which is applied for ASK10
BAF	sCorrection_Entry1	15:0	
BB1	sCorrection_Entry2	15:0	
BB3	sCorrection_Entry3	15:0	
BB5	sCorrection_Entry4	15:0	
BB7	sCorrection_Entry5	15:0	

Table 295. CORRECTION_ENTRY_TABLE (address 0BDAh) EEPROM configuration bit description...continued

Address (hex)	Function	Bit	Description
BB9	sCorrection_Entry6	15:0	
BBB	sCorrection_Entry7	15:0	
BBD	sCorrection_Entry8	15:0	
BBF	sCorrection_Entry9	15:0	
BC1	sCorrection_Entry10	15:0	
BC3	sCorrection_Entry11	15:0	
BC5	sCorrection_Entry12	15:0	
BC7	sCorrection_Entry13	15:0	
BC9	sCorrection_Entry14	15:0	
BCB	sCorrection_Entry15	15:0	
BCD	sCorrection_Entry16	15:0	
BCF	sCorrection_Entry17	15:0	
BD1	sCorrection_Entry18	15:0	
BD3	sCorrection_Entry19	15:0	
BD5	sCorrection_Entry20	15:0	
BD7	sCorrection_Entry21	15:0	
BD9	sCorrection_Entry22	15:0	
BDB	sCorrection_Entry23	15:0	
BDD	sCorrection_Entry24	15:0	
BDF	sCorrection_Entry25	15:0	
BE1	sCorrection_Entry26	15:0	
BE3	sCorrection_Entry27	15:0	
BE5	sCorrection_Entry28	15:0	
BE7	sCorrection_Entry29	15:0	
BE9	sCorrection_Entry30	15:0	
BEB	sCorrection_Entry31	15:0	
BED	sCorrection_Entry32	15:0	
BEF	sCorrection_Entry33	15:0	
BF1	sCorrection_Entry34	15:0	
BF3	sCorrection_Entry35	15:0	
BF5	sCorrection_Entry36	15:0	
BF7	sCorrection_Entry37	15:0	
BF9	sCorrection_Entry38	15:0	
BFB	sCorrection_Entry39	15:0	
bfd	sCorrection_Entry40	15:0	
BFF	sCorrection_Entry41	15:0	

Table 295. CORRECTION_ENTRY_TABLE (address 0BDAh) EEPROM configuration bit description...continued

Address (hex)	Function	Bit	Description
C01	sCorrection_Entry42	15:0	

9.24.168 RTRANS_FTRANS_TABLE (0C03h)

Table 296. RTRANS_FTRANS_TABLE (address C03h) EEPROM configuration bit description

Address (hex)	Function	Bit	Description
C03	RTRANS0	31:0	These values apply in case EDGE_STYLE = 0 is configured for the rising edge
C07	RTRANS1	31:0	These values apply in case EDGE_STYLE = 0 is configured for the rising edge
C0B	RTRANS2	31:0	These values apply in case EDGE_STYLE = 0 is configured for the rising edge
C0F	RTRANS3	31:0	These values apply in case EDGE_STYLE = 0 is configured for the rising edge
C13	FTRANS0	31:0	These values apply in case EDGE_STYLE = 0 is configured for the falling edge
C17	FTRANS1	31:0	These values apply in case EDGE_STYLE = 0 is configured for the falling edge
C1B	FTRANS2	31:0	These values apply in case EDGE_STYLE = 0 is configured for the falling edge
C1F	FTRANS3	31:0	These values apply in case EDGE_STYLE = 0 is configured for the falling edge
C23	RTRANS0	31:0	These values apply in case EDGE_STYLE = 1 is configured for the rising edge
C27	RTRANS1	31:0	These values apply in case EDGE_STYLE = 1 is configured for the rising edge
C2B	RTRANS2	31:0	These values apply in case EDGE_STYLE = 1 is configured for the rising edge
C2F	RTRANS03	31:0	These values apply in case EDGE_STYLE = 1 is configured for the rising edge
C33	FTRANS0	31:0	These values apply in case EDGE_STYLE = 1 is configured for the falling edge
C37	FTRANS1	31:0	These values apply in case EDGE_STYLE = 1 is configured for the falling edge
C3B	FTRANS2	31:0	These values apply in case EDGE_STYLE = 1 is configured for the falling edge
C3F	FTRANS3	31:0	These values apply in case EDGE_STYLE = 1 is configured for the falling edge
C43	RTRANS0	31:0	These values apply in case EDGE_STYLE = 2 is configured for the rising edge
C47	RTRANS1	31:0	These values apply in case EDGE_STYLE = 2 is configured for the rising edge
C4B	RTRANS2	31:0	These values apply in case EDGE_STYLE = 2 is configured for the rising edge
C4F	RTRANS03	31:0	These values apply in case EDGE_STYLE = 2 is configured for the rising edge
C53	FTRANS0	31:0	These values apply in case EDGE_STYLE = 2 is configured for the falling edge
C57	FTRANS1	31:0	These values apply in case EDGE_STYLE = 2 is configured for the falling edge
C5B	FTRANS2	31:0	These values apply in case EDGE_STYLE = 2 is configured for the falling edge
C5F	FTRANS3	31:0	These values apply in case EDGE_STYLE = 2 is configured for the falling edge
C63	RTRANS0	31:0	These values apply in case EDGE_STYLE = 3 is configured for the rising edge
C67	RTRANS1	31:0	These values apply in case EDGE_STYLE = 3 is configured for the rising edge
C6B	RTRANS2	31:0	These values apply in case EDGE_STYLE = 3 is configured for the rising edge
C6F	RTRANS03	31:0	These values apply in case EDGE_STYLE = 3 is configured for the rising edge
C73	FTRANS0	31:0	These values apply in case EDGE_STYLE = 3 is configured for the falling edge
C77	FTRANS1	31:0	These values apply in case EDGE_STYLE = 3 is configured for the falling edge

Table 296. RTRANS_FTRANS_TABLE (address C03h) EEPROM configuration bit description...continued

Address (hex)	Function	Bit	Description
C7B	FTRANS2	31:0	These values apply in case EDGE_STYLE = 3 is configured for the falling edge
C7F	FTRANS3	31:0	These values apply in case EDGE_STYLE = 3 is configured for the falling edge

This table applies only, if the transmitter shaping configuration is (EDGE_TYPE_xx) 4, 5, or 6.

Which of the entries RTRANS0..3 (rising transition) / FTRANS0..3 (falling transition) is applied, is defined by the EDGE_STYLE.

9.24.169 CFG_NOV_CAL (0C83h)

TX non-overlap feature - defines the non-overlap time of TX1, TX2.

Table 297. CFG_NOV_CAL (address 0083h) EEPROM configuration bit description

Address (hex)	Function	Bit	Description
1	RFU	7:2	-
	CALIBRATION_TYPE	1:0	00 = No calibration performed, needs to be updated to 01 or 10 before the first RF on of the chip is performed 01 = Enable FW calibration after every cold boot 10 = Use calibration value coming from EEPROM NOV_CAL_VAL1, NOV_CAL_VAL2 (Default) 11 = RFU

9.24.170 NOV_CAL_VAL1 (0C84h)

Table 298. NOV_CAL_VAL1 (address 0C84h) EEPROM configuration bit description

Address (hex)	Function	Bit	Description
1	VddpaCalVal1	7	It defines the VDDPA value that FW will use to perform NOV calibration group #1. value = 03h (1.8 V) value = 0Dh (2.8 V) See "TxLdoVddpaHigh" parameter for list of voltage

9.24.171 NOV_CAL_VAL2 (0C85h)

Table 299. NOV_CAL_VAL2 (0C85h) EEPROM configuration bit description

Address (hex)	Function	Bit	Description
1	VddpaCalVal2	7	It defines the VDDPA value that FW will use to perform NOV calibration group #2. default value = 15h (3.6 V) default value = 24h (5.1 V) See "TxLdoVddpaHigh" parameter for list of voltage

9.24.172 NOV_CAL_THRESHOLD (0C86h)

Table 300. NOV_CAL_THRESHOLD (address 0C86h) EEPROM configuration bit description

Address (hex)	Function	Bit	Description
1	CfgThreshold	7	It defines VDDPA threshold that FW will use to select Group #1 or Group #2 NOV offset values. default value = 08h (2.3 V) default value = 16h (3.7 V) See "TxLdoVddpaHigh" parameter for list of voltage

9.24.173 NOV_CAL_OFFSET1 (0C87h)

Table 301. NOV_CAL_OFFSET1 (address 0C87h) EEPROM configuration bit description

Address (hex)	Function	Bit	Description
1	UserOffsets1	7	It defines user static offsets applied if CfgNovCal[1:0] = 10b bits[04:00] Group #2 (CfgThreshold to VDDPA max), offset_3l bits[12:08] Group #2 (CfgThreshold to VDDPA max), offset_3l_p2 bits[20:16] Group #2 (CfgThreshold to VDDPA max), offset_2l<0> bits[28:24] Group #2 (CfgThreshold to VDDPA max), offset_2l<1>

9.24.174 NOV_CAL_OFFSET2 (0C8Bh)

Table 302. NOV_CAL_OFFSET1 (address 0C8Bh) EEPROM configuration bit description

Address (hex)	Function	Bit	Description
1	UserOffsets2	7	It defines user static offsets applied if CfgNovCal[1:0] = 10b bits[04:00] Group #2 (CfgThreshold to VDDPA max), offset_3l bits[12:08] Group #2 (CfgThreshold to VDDPA max), offset_3l_p2 bits[20:16] Group #2 (CfgThreshold to VDDPA max), offset_2l<0> bits[28:24] Group #2 (CfgThreshold to VDDPA max), offset_2l<1>

9.24.175 VDDPA_DISCHARGE (0C8Fh)

Table 303. VDDPA_DISCHARGE (address 0C8Fh) EEPROM configuration bit description

Address (hex)	Function	Bit	Description
C8F	RFU	7:1	RFU
	EnableFastVDDP ADischarge	0	1 - Enables fast discharge of VDDPA by setting VDDPA=5.7 and then to 1.5 V, during RF OFF 0 - Enables fast discharge of VDDPA by setting VDDPA=5.7 and then to 1.5 V, during RF OFF

9.24.176 ARC_RM_A106_FDT (0C9Dh)

This is the setting for type A-106.

Table 304. ARC_RM_A106_FDT (address 0C9Dh) EEPROM configuration bit description

Address (hex)	Function	Bit	Description
CA5	RM_RX_ARC_FDT_4	15:0	Bit[15]: RFU Bit [14]: Has to be always "0" Bits[13:10] = RFU Bit [9] = Enable the IIR filter. Bits[8:7] = MF_GAIN (this value will be applied to the SIGPR_RM_TECH register, applies as soon as the ARC is enabled) Bits[6:0] = DPC_SIGNAL_DETECT_TH_OVR_VAL (this value will be applied to the DGRM_RSSI register, applies as soon as the ARC is enabled)
CA3	RM_RX_ARC_FDT_3	15:0	Bit[15]: RFU Bit [14]: Has to be always "0" Bits[13:10] = RFU Bit [9] = Enable the IIR filter. Bits[8:7] = MF_GAIN (this value will be applied to the SIGPR_RM_TECH register, applies as soon as the ARC is enabled) Bits[6:0] = DPC_SIGNAL_DETECT_TH_OVR_VAL (this value will be applied to the DGRM_RSSI register, applies as soon as the ARC is enabled)
CA1	RM_RX_ARC_FDT_2	15:0	Bit[15]: RFU Bit [14]: Has to be always "0" Bits[13:10] = RFU Bit [9] = Enable the IIR filter. Bits[8:7] = MF_GAIN (this value will be applied to the SIGPR_RM_TECH register, applies as soon as the ARC is enabled) Bits[6:0] = DPC_SIGNAL_DETECT_TH_OVR_VAL (this value will be applied to the DGRM_RSSI register, applies as soon as the ARC is enabled)
C9F	RM_RX_ARC_FDT_1	15:0	Bit[15]: RFU Bit [14]: Has to be always "0" Bits[13:10] = RFU Bit [9] = Enable the IIR filter. Bits[8:7] = MF_GAIN (this value will be applied to the SIGPR_RM_TECH register, applies as soon as the ARC is enabled) Bits[6:0] = DPC_SIGNAL_DETECT_TH_OVR_VAL (this value will be applied to the DGRM_RSSI register, applies as soon as the ARC is enabled)
C9D	RM_RX_ARC_FDT_0	15:0	Bit[15]: RFU Bit [14]: Has to be always "0" Bits[13:10] = RFU Bit [9] = Enable the IIR filter. Bits[8:7] = MF_GAIN (this value will be applied to the SIGPR_RM_TECH register, applies as soon as the ARC is enabled) Bits[6:0] = DPC_SIGNAL_DETECT_TH_OVR_VAL (this value will be applied to the DGRM_RSSI register, applies as soon as the ARC is enabled)

Note: For ISO14443-A: In case ARC is disabled, it requires DPC_SIGNAL_DETECT_TH_OVR_VAL larger than 0x50 (with MF_GAIN = 2 (default))

Note: For ISO14443-A: In case Bit[15] is configured to 0, it requires DPC_SIGNAL_DETECT_TH_OVR_VAL larger than 0x50 (with MF_GAIN = 2 (default)) if the ARC is enabled.

Note: The IIR settings define an all pass filter with approximately -10 dB gain. This can be used to limit the LMA sensitivity of the RX.

9.24.177 Tx_Symbol23_Mod_Reg_BR_53 (0CC5h)

Table 305. Tx_Symbol23_Mod_Reg_BR_53 (0CC5Eh) EEPROM configuration bit description

Address (hex)	Function	Bit	Description
CC5	15693_BR_CFG	31:0	CLIF_TX_SYMBOL23_MOD_REG value loaded for 15693 BR 53 kbit/s

9.24.178 Tx_Data_Mod_Reg_BR_53 (0CC9h)

Table 306. Tx_Data_Mod_Reg_BR_53 (0CC9Eh) EEPROM configuration bit description

Address (hex)	Function	Bit	Description
CC9	15693_BR_CFG	31:0	CLIF_TX_Data_MOD_REG value loaded for 15693 BR 53 kbit/s

9.24.179 Tx_Symbol23_Mod_Reg_BR_106 (0CCDh)

Table 307. Tx_Symbol23_Mod_Reg_BR_106 (0CCDEh) EEPROM configuration bit description

Address (hex)	Function	Bit	Description
CCD	15693_BR_CFG	31:0	CLIF_TX_Symbol23_MOD_REG value loaded for 15693 BR 106 kbit/s

9.24.180 Tx_Data_Mod_Reg_BR_106 (0CD1h)

Table 308. Tx_Data_Mod_Reg_BR_106 (0CD1Eh) EEPROM configuration bit description

Address (hex)	Function	Bit	Description
CD1	15693_BR_CFG	31:0	CLIF_TX_Data_MOD_REG value loaded for 15693 BR 106 kbit/s

9.24.181 Tx_Symbol23_Mod_Reg_BR_212 (0CD5h)

Table 309. Tx_Symbol23_Mod_Reg_BR_212 (0CD5Eh) EEPROM configuration bit description

Address (hex)	Function	Bit	Description
CD5	15693_BR_CFG	31:0	CLIF_TX_Symbol23_MOD_REG value loaded for 15693 BR 212 kbit/s

9.24.182 Tx_Data_Mod_Reg_BR_212 (0CD9h)

Table 310. Tx_Data_Mod_Reg_BR_212 (0CD9Eh) EEPROM configuration bit description

Address (hex)	Function	Bit	Description
CD9	15693_BR_CFG	31:0	CLIF_TX_Data_MOD_REG value loaded for 15693 BR 212 kbit/s

10 Limiting values

Table 311. Limiting values

In accordance with the Absolute Maximum Rating System (IEC 60134).

Symbol	Parameter	Conditions	Min	Max	Unit
$V_{DD(VUP_TX)}$	supply voltage on pin VUP_TX	-	-0.3	5.8	V
$V_{DD(VBAT)}$	supply voltage on pin VBAT	-	-0.3	5.8	V
$V_{DD(VDDIO)}$	supply voltage on pin VDDIO	on pin VDDIO, power supply for host interface and GPIOs	-0.3	3.8	V
$V_{DD(VDDPA)}$	supply voltage on pin VDDPA	maximum limiting values for $I_{DD(VDDPA)}$ and $T_{j(max)}$ not violated	-	6.0	V
$V_{i(RXP)}$	input voltage on pin RXP	-	-0.3	+ 2.0	V
$V_{i(RXN)}$	input voltage on pin RXN	-	-0.3	+ 2.0	V
V_{ESD}	electrostatic discharge voltage	human body model (HBM) ^[1]	-2000	2000	V
		charge device model (CDM) ^[2]	-500	+500	V
$T_{j(max)}$	junction temperature	-	-	125	°C
T_{stg}	storage temperature	no supply voltage applied	-55	+150	°C

[1] According to ANSI/ESDA/JEDEC JS-001

[2] According to ANSI/ESDA/JEDEC JS-002

Stress above one or more of the limiting values may cause permanent damage to the device or limit the lifetime.

Product might not behave according to specification.

11 Characteristics

This chapter describes the electrical characteristics for the usage of the product.

Functionality according to this specification and compliancy to referred standards is guaranteed if the device is operated within the limits.

For further information, refer to the PQP (product qualification package) which summarizes the results of the characterization and qualification performed.

11.1 Thermal characteristics

Table 312. Operating conditions

Symbol	Parameter	Conditions	Min	Typ	Max	Unit
T _{amb}	ambient operating temperature	in still air with exposed pins soldered on a 4 layer JEDEC PCB, transmitter output current up to 350 mA	-40	+25	+85	°C
		depends on operating condition: Supply voltage, without DC-DC, Transmitter current	-40	+25	+105	°C

Table 313. Thermal characteristics HVQFN40 package

Symbol	Parameter	Conditions	Typ	Unit
R _{th(j-a)}	thermal resistance from junction to ambient	in free air with exposed pad soldered on a 4 layer JEDEC PCB, package HVQFN40	44.2	K/W
R _{th(j-c)}	thermal resistance from junction to case	-	24.2	K/W

Table 314. Thermal characteristics VFBGA64 package

Symbol	Parameter	Conditions	Typ	Unit
R _{th(j-a)}	thermal resistance from junction to ambient	in free air with exposed pad soldered on a 4 layer JEDEC PCB, package VFBGA64	53	K/W
R _{th(j-c)}	thermal resistance from junction to case	-	22	K/W

Table 315. Junction Temperature

Symbol	Parameter	Conditions	Min	Max	Unit
T _{j_max}	maximum junction temperature	-	-	+125	°C

Table 316. Thermal Shutdown Temperature

Symbol	Parameter	Conditions	Typ	Unit
T_{shutdown}	shutdown of chip due to high temperature detected by temp sensor	-	125	°C

11.2 Static characteristics

Table 317. Supply voltage

Symbol	Parameter	Conditions	Min	Typ	Max	Unit
$V_{\text{DD}}(\text{VBAT_PWR})$	supply voltage on pin VBAT_PWR (DC-DC input pin)	DC-DC disabled	2.4	-	5.5	V
		DC-DC enabled	2.8	-	4.8	V
$V_{\text{DD}}(\text{VUP_TX})$	supply voltage on pin VUP_TX (TX_LDO input pin)	Remark: If DC-DC is used, its output $V_{\text{DD}}(\text{BOOST})$ Min is limited to 3.1 V	2.4	-	6.0	V
$V_{\text{DD}}(\text{VDDPA})$	supply voltage on pin VDDPA (input of the transmitter power amplifier)	-	1.5	-	5.7	V
$V_{\text{DD}}(\text{VBAT})$	supply voltage on pin VBAT (analog and digital supply)	$\text{VBAT} \geq \text{VDDIO}$	2.4	-	5.5	V
$V_{\text{DD}}(\text{VDDIO})$	supply voltage on pin VDDIO (supply for host interface and GPIOs)	typical 1.8 V interface supply voltage	1.62	-	1.98	V
		typical 3.3 V interface supply voltage	2.4	-	3.6	V
$V_{\text{I}}(\text{RXP})$	input voltage on pin RXP	-	-0.5	-	1.8	V
$V_{\text{I}}(\text{RXN})$	input voltage on pin RXN	-	-0.5	-	1.8	V

Note: The voltage on pin VDDIO must always be smaller or equal to the voltage on pin VBAT.

Table 318. Current consumption in active mode

Symbol	Parameter	Conditions	Min	Typ	Max	Unit
$I_{\text{DD}}(\text{VBAT})$	system supply		-	-	20	mA
$I_{\text{DD}}(\text{VDDIO})$		This current depends on the output current of peripherals. At no time, the sum of the maximum output currents shall exceed $I_{\text{DD}}(\text{VDDIO})_{\text{max}}$	-	-	30	mA
$I_{\text{DD}}(\text{BOOST_IN})$	DC-DC boost supply	average input current	-	-	1.0	A
		peak input current (short peak)	-	-	1.7	A
$I_{\text{DD}}(\text{VUP_TX})$	input supply for transmitter LDO	-	-	-	350	mA
$I_{\text{DD}}(\text{VDDPA})$	RF power amplifier (transmitter) current	supplied via VUP_TX (TX_LDO active)	-	-	350	mA

Table 318. Current consumption in active mode...continued

Symbol	Parameter	Conditions	Min	Typ	Max	Unit
		supplied without DC-DC and TXLDO active	-	-	400	mA

Table 319. Current consumption during power-saving modes

Symbol	Parameter	Conditions	Min	Typ	Max	Unit
$I_{\text{OFF Plus Mode}}$ (VDDIO+VBAT)	sum of supply current on pin VDDIO and VBAT in OFF Plus mode	25 °C ambient operating temperature	-	5	-	μA
$I_{\text{OFF Plus ULFO Mode}}$ (VDDIO+VBAT)	sum of supply current on pin VDDIO and VBAT in OFF Plus mode, ULFO active (ULPCD during RF-OFF)	25 °C ambient operating temperature	-	5	-	μA
$I_{\text{hard power down}}$ (VDDIO+VBAT)	sum of supply current on pin VDDIO and VBAT in hard power-down mode	25 °C ambient operating temperature	-	40	105	μA
I_{standby} (VDDIO+VBAT)	sum of supply current on pin VDDIO and VBAT in standby mode	25 °C ambient operating temperature	-	45	110	μA
I_{suspend} (VBAT)	supply current on pin VBAT in suspend mode	25 °C ambient operating temperature	-	2.5	-	mA
I_{ULPCD} (VDDIO+VBAT)	sum of supply current on pin VDDIO and VBAT in ULPCD (Ultra Low-Power Card Detection) mode	25 °C ambient operating temperature, VBAT supply voltage 3.3 V, antenna matching 50 R, 3.3 V antenna supply voltage, 3x RF-on per second	-	22	-	μA
I_{LPCD} (VDDIO+VBAT)	sum of supply current on pin VDDIO and VBAT in LPCD (Enhanced Low-Power Card Detection with highest sensitivity) mode, without DC-DC used	25 °C ambient operating temperature, VBAT supply voltage 3.3 V, antenna matching 50 R, 3.3 V antenna supply voltage, 3x RF-on per second	-	240	-	μA

Table 320. Overcurrent detection function ^[1]

Symbol	Parameter	Conditions	Min	Typ	Max	Unit
I_{DD} (VUP_TX)	current of overcurrent detection becoming active	-	450	550	650	mA

[1] Please refer to the Errata sheet if the device is used with smaller or equal than FW2.1.

This is a safety feature only. A design shall not functionally rely on this feature since the operating conditions will be violated if the overcurrent detection becomes active.

Table 321. VEN pin

Symbol	Parameter	Conditions	Min	Typ	Max	Unit
V _{IH}	HIGH-level input voltage	V _{DD(VDDIO)} ≤ V _{DD(VBAT)}	0.7 * V _{DD(VDDIO)}	-	V _{DD(VDDIO)}	V
V _{IL}	LOW-level input voltage		0	-	0.3 * V _{DD(VDDIO)}	V
I _{IH}	HIGH-level input current	V _I = V _{DD(VBAT)}	-	-	1	μA
I _{IL}	LOW-level input current	V _I = 0 V	-1	-	-	μA
C _i	input capacitance		-	5	-	pF
t _(ULPCD_abort)	VEN time required to abort ULPCD		5	-	-	ms

Table 322. GPIO (GPIO_0, GPIO_1, GPIO_2, GPIO_3, GPIO4, GPIO5) pins

Symbol	Parameter	Conditions	Min	Typ	Max	Unit
V _{IH}	HIGH-level input voltage	V _{DD(VDDIO)} ≤ V _{DD(VBAT)} ; 1.62 ≤ VDDIO ≤ 1.98 or 2.4 ≤ VDDIO ≤ 3.6	0.65x VDDIO	-	VDDIO+0.5	V
V _{IL}	LOW-level input voltage	V _{DD(VDDIO)} ≤ V _{DD(VBAT)} ; 1.62 ≤ VDDIO ≤ 1.98 or 2.4 ≤ VDDIO ≤ 3.6	- 0.5	-	0.35 × VDDIO	V
V _{OH}	HIGH-level output voltage	V _{DD(VDDIO)} = 3.3 V	VDDIO - 0.4	-	VDDIO	V
V _{OL}	LOW-level output voltage	V _{DD(VDDIO)} = 3.3 V	0	-	0.4	V
I _{OH}	HIGH-level output current	V _{DD(VDDIO)} = 3.3 V	-	-	3	mA
I _{OL}	LOW-level output current	V _{DD(VDDIO)} = 3.3 V	-	-	3	mA
R _{PU}	Weak pullup resistor	-	40	50	62	kΩ
R _{PD}	Weak pull-down resistor	-	40	50	62	kΩ

Table 323. CLK1, CLK2 pins

Symbol	Parameter	Conditions	Min	Typ	Max	Unit
V _{i(p-p)}	peak-to-peak input voltage	-	0.4	-	1.65	V
I _{IH}	HIGH-level input current	V _I = 1.65 V, no power saving, active mode	-	-	5	μA
I _{IL}	LOW-level input current	V _I = 0 V, no power saving, active mode	-	-	1	μA
δ	duty cycle	-	35	-	65	%
C _{i(CLK1)}	input capacitance on pin CLK1	VDD = 1.8 V, VDC = 0.65 V, VAC = 0.9 V (p-p)	-	1	-	pF

Table 323. CLK1, CLK2 pins ...continued

Symbol	Parameter	Conditions	Min	Typ	Max	Unit
$C_{i(\text{CLK2})}$	input capacitance on pin CLK2	VDD = 1.8 V, VDC = 0.65 V, VAC = 0.9 V (p-p)	-	1	-	pF

Table 324. IRQ pin

Symbol	Parameter	Conditions	Min	Typ	Max	Unit
V_{OH}	HIGH-level output voltage	$I_{\text{OH}} < 3 \text{ mA}$	$V_{\text{DD}(\text{VDDIO})} - 0.4$	-	$V_{\text{DD}(\text{VDDIO})}$	V
V_{OL}	LOW-level output voltage	$I_{\text{OL}} < 3 \text{ mA}$	0	-	0.4	V
I_{OH}	HIGH-level output current		-	-	3	mA
I_{OL}	LOW-level output current		-	-	3	mA
C_{L}	load capacitance		-	-	10	pF
t_{f}	fall time	$C_{\text{L}} = 12 \text{ pF max}$	1	-	3	ns
t_{r}	rise time	$C_{\text{L}} = 12 \text{ pF max}$	1	-	3	ns
R_{pd}	pull-down resistance		40	-	62	k Ω

Table 325. SCLK, MOSI, NSS pins

Symbol	Parameter	Conditions	Min	Typ	Max	Unit
V_{IH}	HIGH-level input voltage		$0.65 \times V_{\text{DD}(\text{VDDIO})}$	-	$V_{\text{DD}(\text{VDDIO})}$	V
V_{IL}	LOW-level input voltage		- 0.5	-	$0.35 \times V_{\text{DD}(\text{VDDIO})}$	V
I_{IH}	HIGH-level input current	$V_{\text{I}} = V_{\text{VDDIO}}$	-	-	1	μA
I_{IL}	LOW-level input current	$V_{\text{I}} = 0 \text{ V}$	-	-	1	μA
C_{i}	input capacitance		-	5	-	pF

Table 326. MISO pin

Symbol	Parameter	Conditions	Min	Typ	Max	Unit
V_{OH}	HIGH-level output voltage	$I_{\text{OH}} < 3 \text{ mA}$	$V_{\text{DD}(\text{VDDIO})} - 0.4$	-	$V_{\text{DD}(\text{VDDIO})}$	V
V_{OL}	LOW-level output voltage	$I_{\text{OL}} < 3 \text{ mA}$	0	-	0.4	V
I_{OH}	HIGH-level output current		-	-	3	mA
I_{OL}	LOW-level output current		-	-	3	mA
C_{L}	load capacitance		-	-	10	pF
t_{f}	fall time	$C_{\text{L}} = 12 \text{ pF max}$	1	-	3	ns
t_{r}	rise time	$C_{\text{L}} = 12 \text{ pF max}$	1	-	3	ns

Table 327. RXP, RXn pins

Symbol	Parameter	Conditions	Min	Typ	Max	Unit
$V_{i(dyn)}$	dynamic input voltage		-	-	1.8	V
C_i	input capacitance		-	1	-	pF
Z_i	input impedance from RXN, RXP pins to VMID	Reader, card and P2P modes	-	-	15	k Ω

Table 328. TX1, TX2 pins

Symbol	Parameter	Conditions	Min	Typ	Max	Unit
V_{OH}	HIGH-level output voltage	$V_{DD(VDDPA)}=5.0$ V; with internal VDDPA LDO	-	$V_{DD(VDDPA)} - 150$ mV	$V_{DD(VDDPA)}$	V
V_{OL}	LOW-level output voltage	$V_{DD(VDDPA)}=5.0$ V; with internal VDDPA LDO	0	200	-	mV

Table 329. AUX1, AUX2, AUX3 pins (Debug output)

Symbol	Parameter	Conditions	Min	Typ	Max	Unit
V_{AUX_OH}	HIGH-level output voltage	pin used as debug signal output	$V_{DDIO} - 0.4$	-	V_{DDIO}	V
V_{AUX_OL}	LOW-level output voltage	pin used as debug signal output	0	-	0.4	mV
I_{AUX_OH}	HIGH-level output current	$V_{DD(VDDIO)} = 3.3$ V	-	-	3.0	mA
I_{AUX_OL}	LOW-level output current	$V_{DD(VDDIO)} = 3.3$ V	-	-	3.0	mA
C_{O_LOAD}	output capacitance load of pin		-	5	10	pF

Table 330. DAC_1, DAC_2 output pins (Tuning DAC)

Symbol	Parameter	Conditions	Min	Typ	Max	Unit
V_{O_max}	HIGH-level maximum output voltage	connected to a variable capacitor (varicap)	-	$V_{DD(VDDIO)}$	3.65	V
V_{O_min}	LOW-level minimum output voltage	connected to a variable capacitor (varicap)	- 0.3	0	200	mV
	DAC resolution		-	-	8	bits
C_{O_LOAD}	output capacitance load of pin		0	-	4	nF

11.3 Timing characteristics

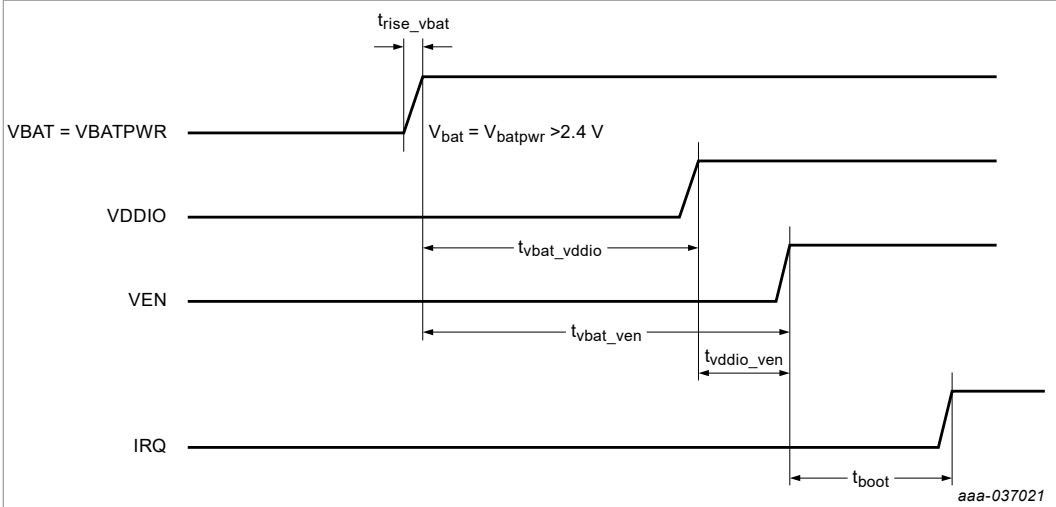

Figure 29. Startup timing

Table 331. Power supply connection timing

Symbol	Parameter	Conditions	Min	Typ	Max	Unit
t_{rise_vbat}	VBAT supply ramp	VEN = Low	0	-	2.75	V/us
t_{vbat_vddio}	time between ramping up VBAT and ramping VDDIO	vddio condition: VBAT>2.4 V, VDDIO supply (External), hpd_off_sel = x	0	500	1000	ms
t_{vbat_ven}	time between ramping VBAT and VEN	vddio condition: VBAT>2.4 V, VDDIO supply (External), hpd_off_sel = x	0	500.5	1001	ms
t_{boot}	start-up time ^[1]	vddio condition: VBAT>2.4 V, VDDIO supply (External), hpd_off_sel = x	3.2	3.27	dependent on configuration of XTAL_BOOT_TIME in EEPROM. This configuration can be used to optimize the boot time for crystals which allow a fast settling. This allows to optimize the average current consumption during ULPCD and LPCD. default EEPROM configuration: 3.4	ms

[1] (PN5190B1 ready to receive commands on the host interface). The PN5190B1 indicates the ability to receive commands from a host by raising an IDLE IRQ.

Table 332. Pulse length

Symbol	Parameter	Conditions	Min	Typ	Max	Unit
$t_{(VEN)}$	on Pin VEN, pulse width to reset the chip or exit from ULPCD / Hard Power Down State	-	5	-	-	ms
$t_{(wake-up)}$	on pin GPIOx, pulse width to wake up	-	1	-	-	μ s
$t_{VEN(GPIO)}$	time from VEN high to GPIO's available for use	-	100	-	-	ms

Table 333. DAC1, DAC2 conversion timing (Tuning DAC)

Symbol	Parameter	Conditions	Min	Typ	Max	Unit
$t_{conversion}$	Conversion speed of 8-bit DAC1, DAC2	1 LSB rising falling, (depends on capacitive load) RF cut resistance: 100 kOhm (max), Cin: 8 nF (max)	-	-	0.15	ms
		Full signal rising from 0.0 V to 3 V, (depends on capacitive load) RF cut resistance: 100 kOhm (max), Cin: 8 nF (max)	-	-	0.15	ms
		falling from 3 V to 300 mV, (depends on capacitive load) RF cut resistance: 100 kOhm (max), Cin: 8 nF (max)	-	-	2	ms

Table 334. SPI interface

Symbol	Parameter	Min	Typ	Max	Unit
t_{SCKL}	SCK LOW time	25	-	-	ns
t_{SCKH}	SCK HIGH time	25	-	-	ns
$t_{h(SCKH-D)}$	SCK HIGH to data input hold time	12.5	-	-	ns
$t_{su(D-SCKH)}$	data input to SCK HIGH set-up time	12.5	-	-	ns
$t_{h(SCKL-Q)}$	SCK LOW to data output hold time	-	-	25	ns

Table 334. SPI interface...continued

Symbol	Parameter	Min	Typ	Max	Unit
$t_{(SCKL-NSSH)}$	SCK LOW to NSS HIGH time	0	-	-	ns
t_{NSSH}	NSS HIGH time	25	-	-	ns

Table 335. RF_ON command timing following a previous RF_OFF

Symbol	Parameter	Conditions	Min	Typ	Max	Unit
$t_{(RF_OFF-RF_ON)}$	RF_ON command timing	guard time between command sends for RF_OFF and command send for RF_ON, capacitors on transmitter need to be fully de-charged before RF_ON command is sent	5.1	5.6	-	ms

11.4 Clock input

Table 336. Crystal requirements for ISO/IEC14443 compliant operation

Symbol	Parameter	Conditions	Min	Typ	Max	Unit
f_{xtal}	crystal frequency	ISO/IEC compliancy	-	27.12	-	MHz
Δf_{xtal}	crystal frequency accuracy	for full RF operating range	-40	-	+40	ppm
ESR	equivalent series resistance	-	10	30	100	Ω
C_L	load capacitance	-	6	8	10	pF
$t_{startupl}$	crystal startup time	-	-	-	1	ms
P_{xtal}	crystal power dissipation	-	-	-	100	μ W

Table 337. Frequency requirements for a direct clock input (no crystal)

Symbol	Parameter	Conditions	Min	Typ	Max	Unit
f_{clk}	clock frequency	ISO/IEC compliancy	-	24	-	MHz
			-	32	-	

Table 337. Frequency requirements for a direct clock input (no crystal) ...continued

Symbol	Parameter	Conditions	Min	Typ	Max	Unit
			-	48	-	
Δf_{clk}	clock frequency accuracy	for full RF operating range	-40	-	+40	ppm
Φ_n	phase noise	input phase noise floor at 100 kHz offset	-	- 150	-145	dBc/Hz
Φ_n	phase noise	input phase noise floor at 1 MHz offset	-	- 152	-149	dBc/Hz
V_i	Input voltage boundary	sinus signal	0	-	1.8	V
$V_{i(p-p)}$	peak-to-peak Input voltage	sinus signal	0.4	-	1.8	V
$V_{i(\text{clk})}$	clock input voltage	square signal	0	-	1.8 +/-10%	V

11.5 EEPROM characteristics

Table 338. EEPROM characteristics

Symbol	Parameter	Conditions	Min	Typ	Max	Unit
$N_{\text{endu}(W)}$	write endurance	at ambient temperature $T_a = +25\text{ }^\circ\text{C}$	100	-	-	K cycles
t_{ret}	retention time	at ambient temperature $T_a = +25\text{ }^\circ\text{C}$	25	-	-	years

12 Package outline

12.1 VFBGA64 package

Table 339. Package outline VFBGA64 (SOT1307-2)

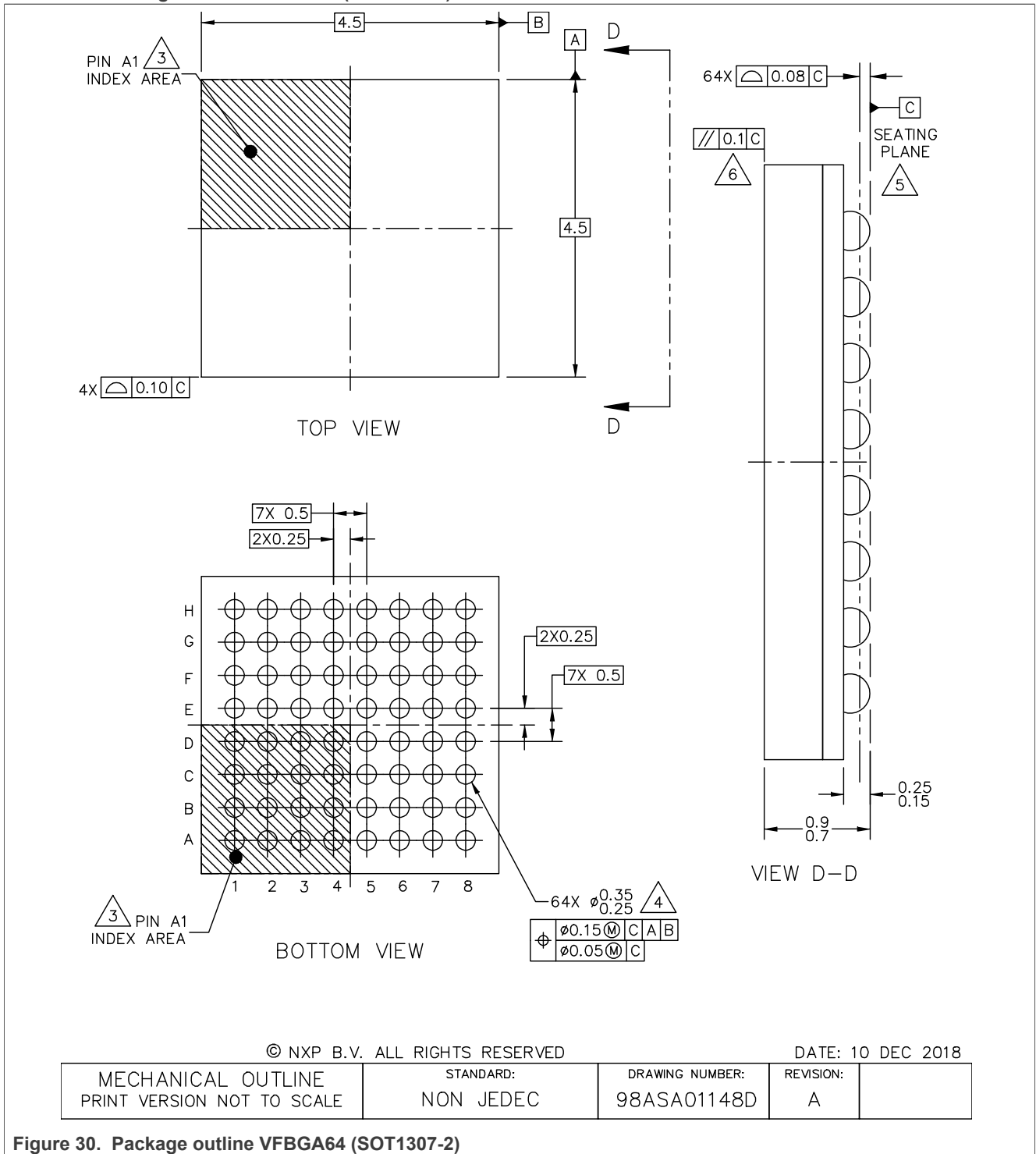

Figure 30. Package outline VFBGA64 (SOT1307-2)

NOTES:

1. ALL DIMENSIONS IN MILLIMETERS.
2. DIMENSIONING AND TOLERANCING PER ASME Y14.5M-1994.
3. PIN A1 FEATURE SHAPE, SIZE AND LOCATION MAY VARY.
4. MAXIMUM SOLDER BALL DIAMETER MEASURED PARALLEL TO DATUM C.
5. DATUM C, THE SEATING PLANE, IS DETERMINED BY THE SPHERICAL CROWNS OF THE SOLDER BALLS.
6. PARALLELISM MEASUREMENT SHALL EXCLUDE ANY EFFECT OF MARK ON TOP SURFACE OF PACKAGE.

© NXP B.V. ALL RIGHTS RESERVED

DATE: 10 DEC 2018

MECHANICAL OUTLINE PRINT VERSION NOT TO SCALE	STANDARD: NON JEDEC	DRAWING NUMBER: 98ASA01148D	REVISION: A	
--	------------------------	--------------------------------	----------------	--

Figure 31. Package outline note VFBGA64 (SOT1307-2)

12.2 HVQFN40 package

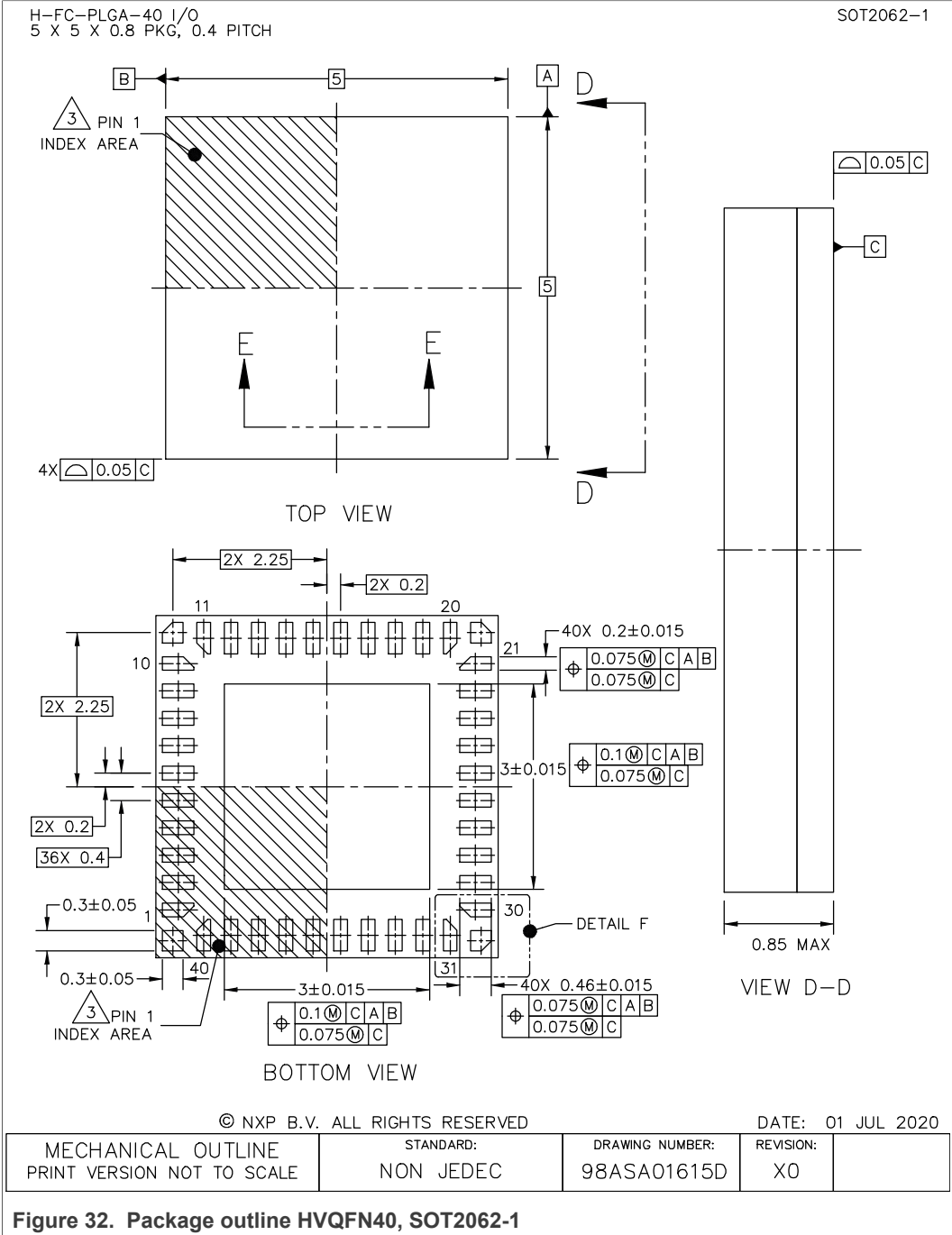

H-FC-PLGA-40 I/O
5 X 5 X 0.8 PKG, 0.4 PITCH

SOT2062-1

NOTES:

1. ALL DIMENSIONS ARE IN MILLIMETERS.
2. DIMENSIONING AND TOLERANCING PER ASME Y14.5M-1994.
3. PIN 1 FEATURE SHAPE, SIZE AND LOCATION MAY VARY.
4. DIMENSION APPLIES TO ALL LEADS.

© NXP B.V. ALL RIGHTS RESERVED

DATE: 01 JUL 2020

MECHANICAL OUTLINE PRINT VERSION NOT TO SCALE	STANDARD: NON JEDEC	DRAWING NUMBER: 98ASA01615D	REVISION: X0	
--	------------------------	--------------------------------	-----------------	--

Figure 33. Package outline detail HVQFN40, SOT2062-1

13 Package marking

13.1 Package marking drawing VFBGA64

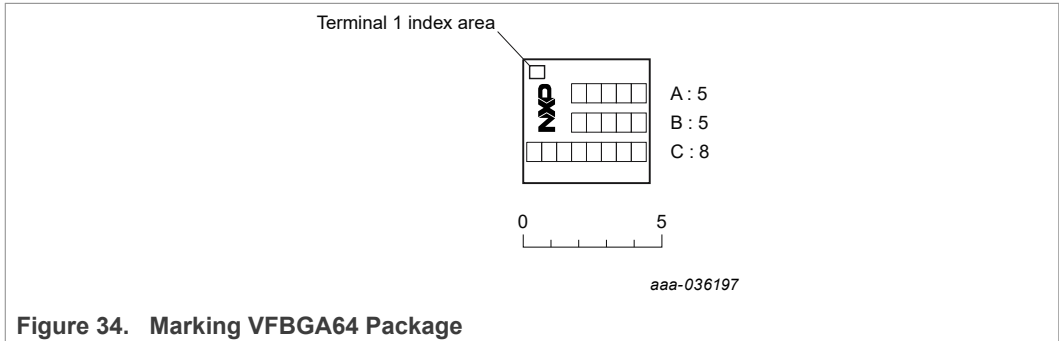

Line A: 5 characters; "PN5190D" (FW2.0) or "5190E" (FW2.1)
 Line B: 5 characters; contains the DB ID and AS ID
 Line C: 8 characters; stDYYWW(X) - contains information assembly center, date code and maturity level ("X" = engineering samples, " " = released product)

13.2 Package marking drawing HVQFN40

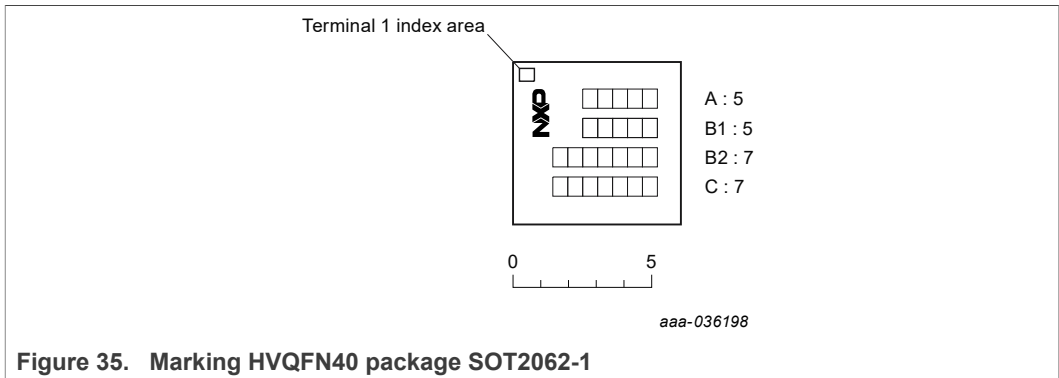

Line A: 5 characters; "PN5190D" (FW2.0) or "5190E" (FW2.1)
 Line B1: 5 characters; contains the DB ID
 Line B2: 7 characters; contains the DB ID (continued) and AS ID (2 digits)
 Line C: 7 characters; stDYYWW(X) - contains information assembly center, date code and maturity level ("X" = engineering samples, "Y" = customer qualification samples, " " = released product)

14 Reflow soldering footprint VFBGA64

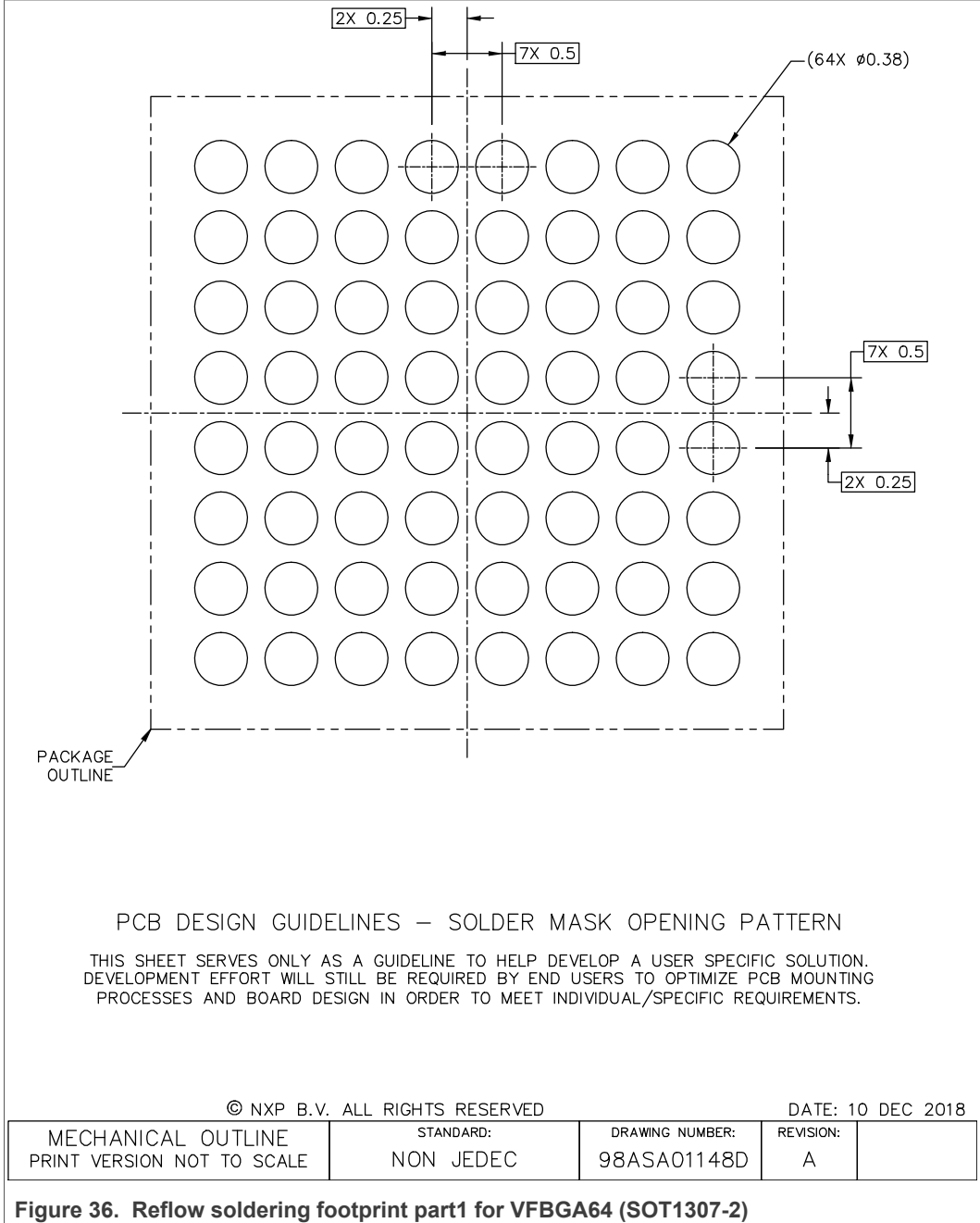

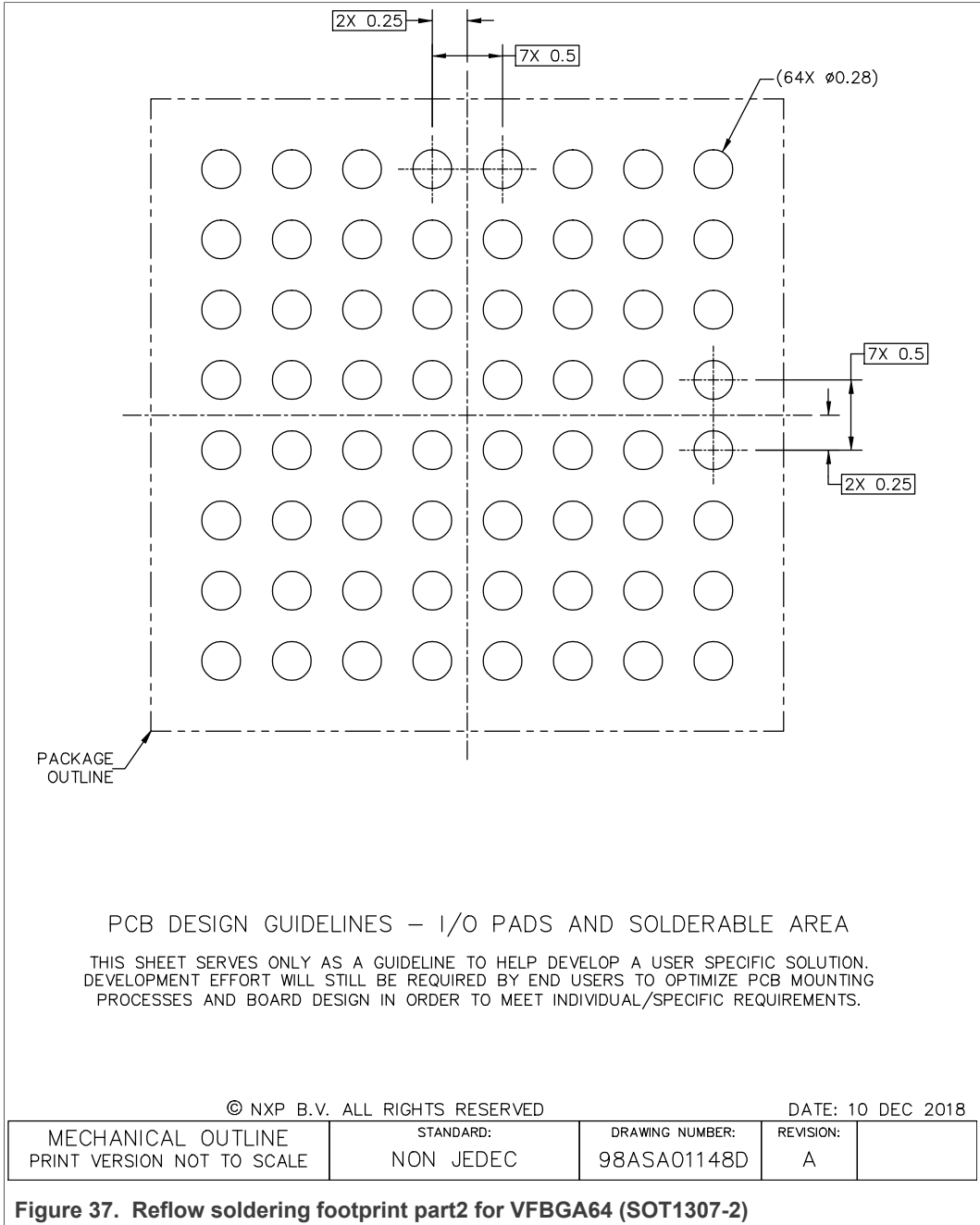

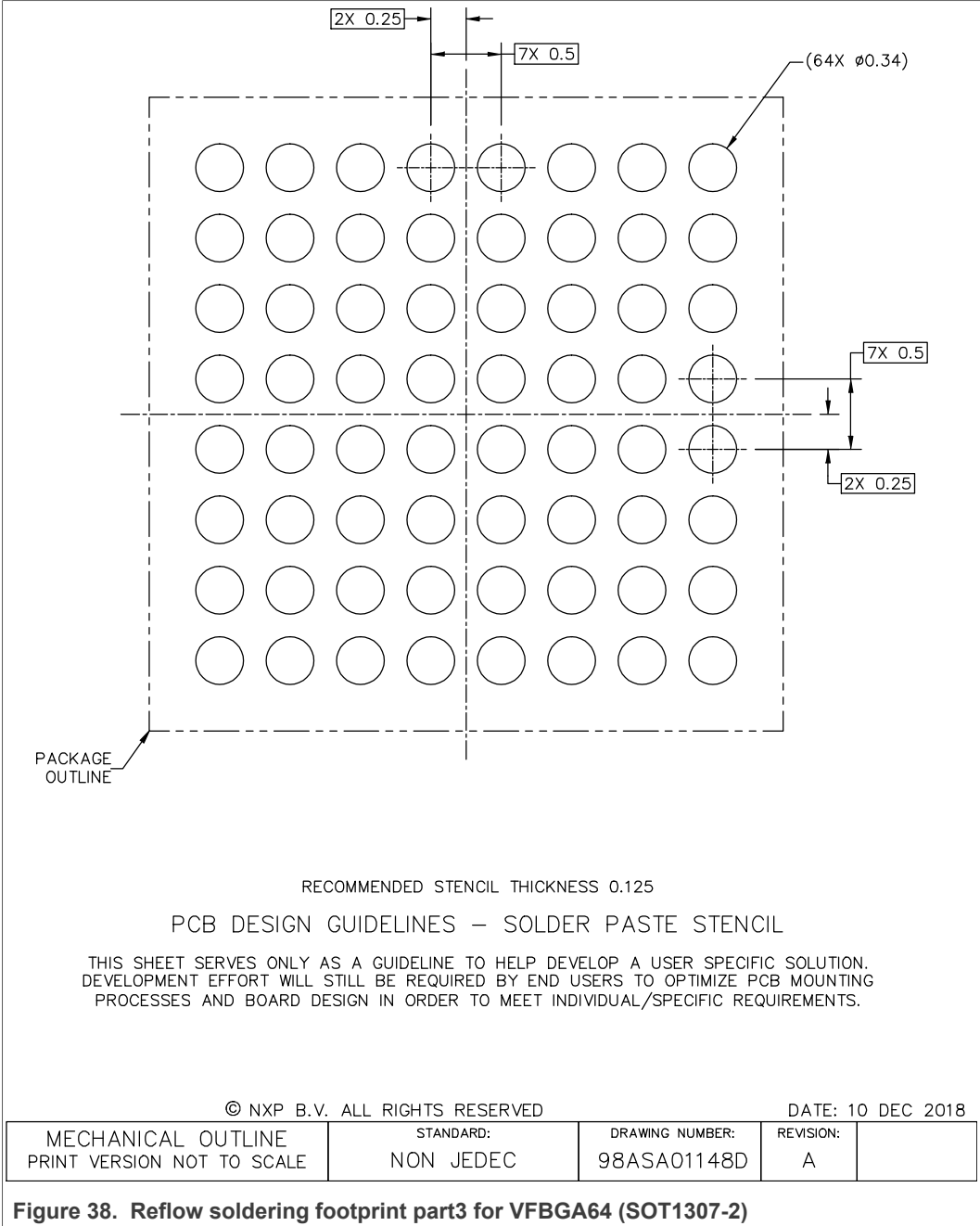

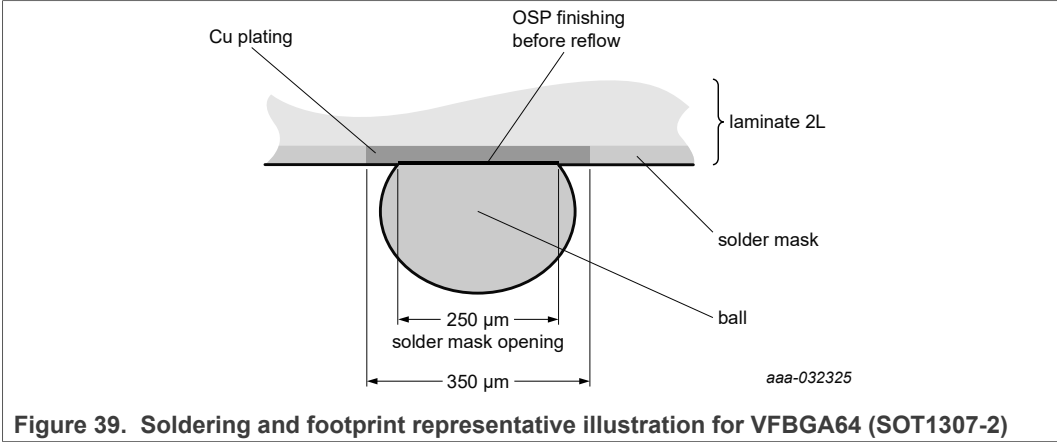
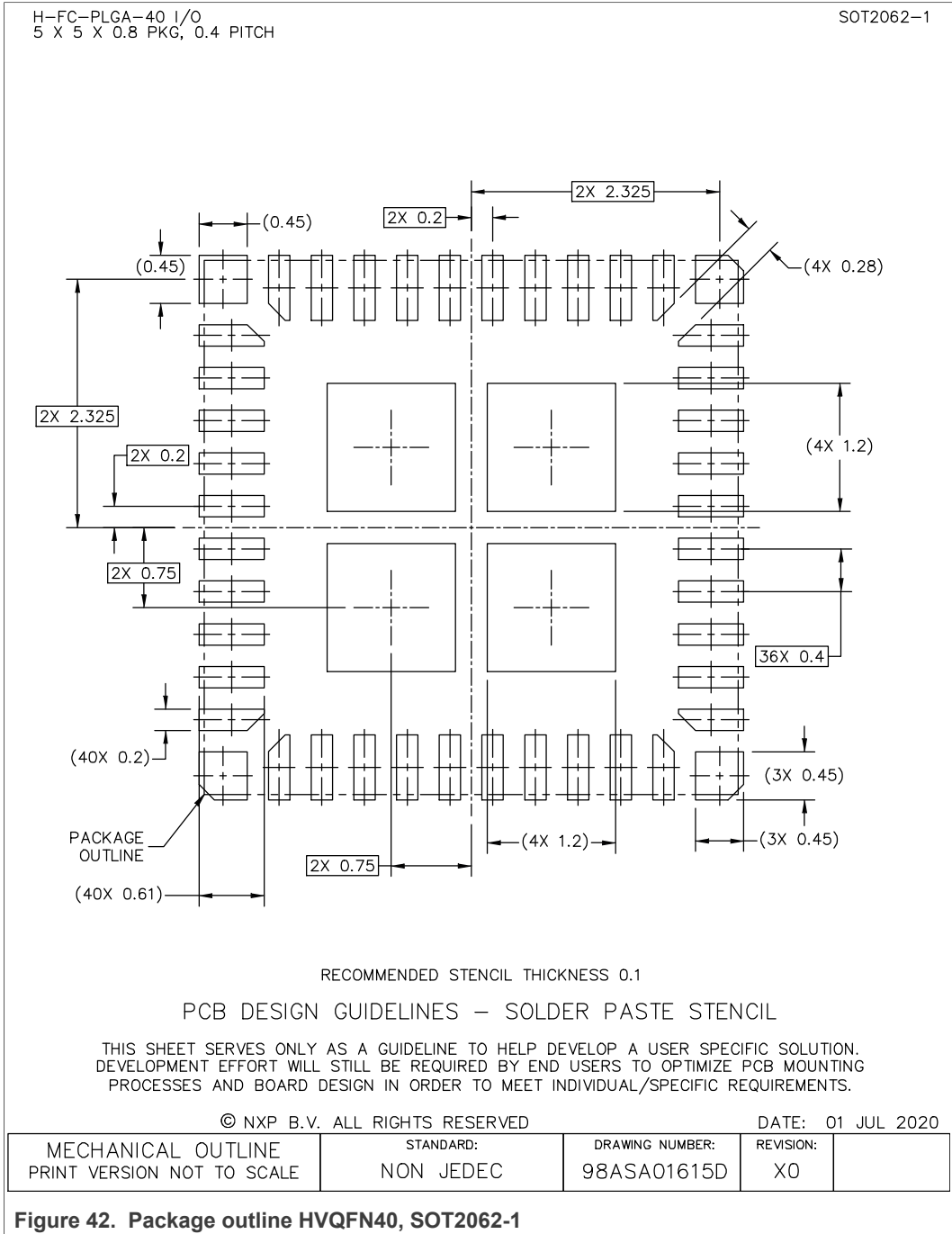
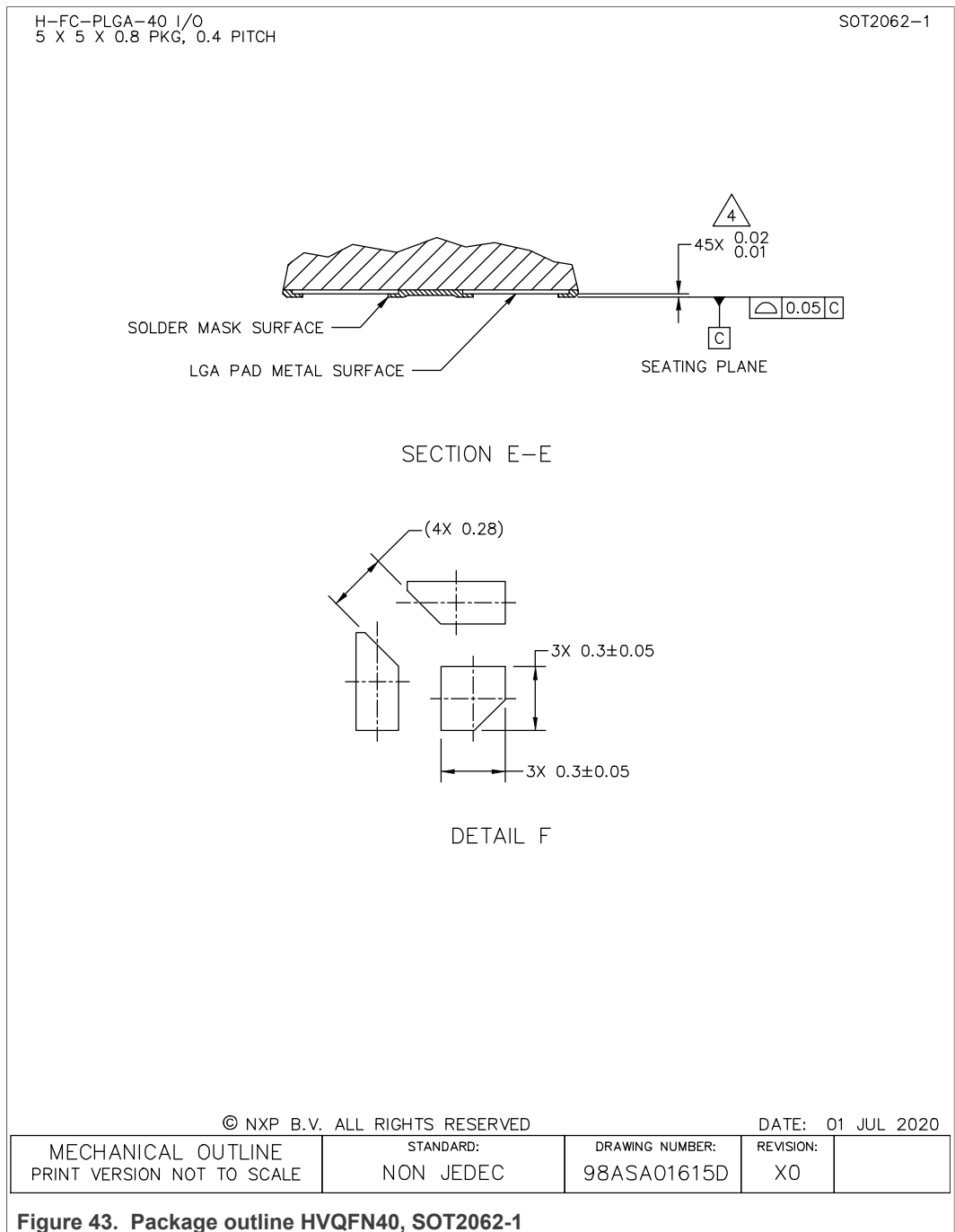

Figure 39. Soldering and footprint representative illustration for VFBGA64 (SOT1307-2)





16 Surface mount reflow soldering

For information on surface mount, reflow soldering and component handling please refer to the related application note.

This application note provides guidelines for the board mounting and handling of NXP Semiconductor packages:

<https://www.nxp.com/docs/en/application-note/AN10365.pdf>

17 Handling information

Moisture Sensitivity Level (MSL) evaluation has been performed according to *SNW-FQ-225B rev.04/07/07 (JEDEC J-STD-020C)*.

An MSL corresponds to a certain out-of-bag time (or floor life). If semiconductor packages are removed from their sealed dry-bags and not soldered within their out-of-bag time, they must be baked prior to reflow soldering, in order to remove any moisture that might have soaked into the package.

For MSL3:

168h out-of-pack floor life at maximum ambient temperature, conditions < 30 °C / 60 % RH.

For MSL2:

- 1 year out-of-pack floor life at maximum ambient temperature, conditions < 30 °C / 60 % RH.

For MSL1:

- No out-of-pack floor live spec. required. Conditions: <30 °C / 85 % RH.

CAUTION



This device is sensitive to ElectroStatic Discharge (ESD). Observe precautions for handling electrostatic sensitive devices. Such precautions are described in the *ANSI/ESD S20.20, IEC/ST 61340-5, JESD625-A* or equivalent standards.

18 Appendix: EEPROM_LOAD_RF_CONFIGURATION FW2.0

```

Firmware 2.0
<?xml version="1.0" encoding="utf-8"?>
<EEPROM>
  <Region RegionName="USER_PMU" RegionAccess="RW" RegionType="DATA">
    <Parameter Name="PwrConfig" Offset="0x00" Value="0xE4" />
    <Parameter Name="DcdcConfig" Offset="0x01" Value="0x31" />
    <Parameter Name="TxLdoConfig" Offset="0x02" Value="0xFFFFAEA7" />
    <Parameter Name="TxLdoVddpaHigh" Offset="0x06" Value="0x00" />
    <Parameter Name="TxLdoVddpaLow" Offset="0x07" Value="0x00" />
    <Parameter Name="TxLdoVddpaMaxRdr" Offset="0x08" Value="0x2A" />
    <Parameter Name="TxLdoVddpaMaxCard" Offset="0x09" Value="0x2A" />
    <Parameter Name="BoostDefaultVoltage" Offset="0x0A" Value="0x1D" />
  </Region>

  <Region RegionName="CLKGEN" RegionAccess="RW" RegionType="DATA">
    <Parameter Name="XtalConfig" Offset="0x10" Value="0x00" />
    <Parameter Name="XtalTimeOut" Offset="0x11" Value="0xFF" />
  </Region>

  <Region RegionName="RF_CLOCK_CFG" RegionAccess="RW" RegionType="DATA">
    <Parameter Name="PLLClkInputFrq" Offset="0x12" Value="0x08" />
    <Parameter Name="XtalCheckDelay" Offset="0x13" Value="0xF6" />
  </Region>

  <Region RegionName="USER_SMU" RegionAccess="RW" RegionType="DATA">
    <Parameter Name="TempWarning" Offset="0x14" Value="0x99" />
    <Parameter Name="EnableGpio0OnOverTemp" Offset="0x16" Value="0x01" />
  </Region>

  <Region RegionName="RM_TECHNO_TX_SHAPING" RegionAccess="RW" RegionType="DATA">
    <Parameter Name="ResidualAmplitudeLevel_A106" Offset="0x22" Value="0x00" />
    <Parameter Name="EdgeType_A106" Offset="0x23" Value="0x33" />
    <Parameter Name="EdgeStyleConfiguration_A106" Offset="0x24" Value="0x64" />
    <Parameter Name="EdgeLength_A106" Offset="0x25" Value="0x10" />
    <Parameter Name="ResidualAmplitudeLevel_A212" Offset="0x26" Value="0x00" />
    <Parameter Name="EdgeType_A212" Offset="0x27" Value="0x33" />
    <Parameter Name="EdgeStyleConfiguration_A212" Offset="0x28" Value="0x44" />
    <Parameter Name="EdgeLength_A212" Offset="0x29" Value="0x10" />
    <Parameter Name="ResidualAmplitudeLevel_A424" Offset="0x2A" Value="0x00" />
    <Parameter Name="EdgeType_A424" Offset="0x2B" Value="0x33" />
    <Parameter Name="EdgeStyleConfiguration_A424" Offset="0x2C" Value="0x24" />
    <Parameter Name="EdgeLength_A424" Offset="0x2D" Value="0x10" />
    <Parameter Name="ResidualAmplitudeLevel_A848" Offset="0x2E" Value="0x00" />
    <Parameter Name="EdgeType_A848" Offset="0x2F" Value="0x11" />
    <Parameter Name="EdgeStyleConfiguration_A848" Offset="0x30" Value="0x18" />
    <Parameter Name="EdgeLength_A848" Offset="0x31" Value="0x10" />
    <Parameter Name="ResidualAmplitudeLevel_B106" Offset="0x32" Value="0xC8" />
    <Parameter Name="EdgeType_B106" Offset="0x33" Value="0x44" />
    <Parameter Name="EdgeStyleConfiguration_B106" Offset="0x34" Value="0x00" />
    <Parameter Name="EdgeLength_B106" Offset="0x35" Value="0x10" />
    <Parameter Name="ResidualAmplitudeLevel_B212" Offset="0x36" Value="0xCF" />
    <Parameter Name="EdgeType_B212" Offset="0x37" Value="0x22" />
    <Parameter Name="EdgeStyleConfiguration_B212" Offset="0x38" Value="0x66" />
    <Parameter Name="EdgeLength_B212" Offset="0x39" Value="0x10" />
    <Parameter Name="ResidualAmplitudeLevel_B424" Offset="0x3A" Value="0xCF" />
    <Parameter Name="EdgeType_B424" Offset="0x3B" Value="0x22" />
    <Parameter Name="EdgeStyleConfiguration_B424" Offset="0x3C" Value="0x55" />
    <Parameter Name="EdgeLength_B424" Offset="0x3D" Value="0x10" />
    <Parameter Name="ResidualAmplitudeLevel_B848" Offset="0x3E" Value="0xCE" />
    <Parameter Name="EdgeType_B848" Offset="0x3F" Value="0x22" />
    <Parameter Name="EdgeStyleConfiguration_B848" Offset="0x40" Value="0x34" />
    <Parameter Name="EdgeLength_B848" Offset="0x41" Value="0x10" />
    <Parameter Name="ResidualAmplitudeLevel_F212" Offset="0x42" Value="0xCF" />
    <Parameter Name="EdgeType_F212" Offset="0x43" Value="0x22" />
    <Parameter Name="EdgeStyleConfiguration_F212" Offset="0x44" Value="0x65" />
    <Parameter Name="EdgeLength_F212" Offset="0x45" Value="0x10" />
    <Parameter Name="ResidualAmplitudeLevel_F424" Offset="0x46" Value="0xCE" />
    <Parameter Name="EdgeType_F424" Offset="0x47" Value="0x22" />
    <Parameter Name="EdgeStyleConfiguration_F424" Offset="0x48" Value="0x55" />
    <Parameter Name="EdgeLength_F424" Offset="0x49" Value="0x10" />
    <Parameter Name="ResidualAmplitudeLevel_V100_26" Offset="0x4A" Value="0x00" />
    <Parameter Name="EdgeType_V100_26" Offset="0x4B" Value="0x33" />
    <Parameter Name="EdgeStyleConfiguration_V100_26" Offset="0x4C" Value="0x66" />
    <Parameter Name="EdgeLength_V100_26" Offset="0x4D" Value="0x10" />
    <Parameter Name="ResidualAmplitudeLevel_V100_53" Offset="0x4E" Value="0x00" />
    <Parameter Name="EdgeType_V100_53" Offset="0x4F" Value="0x33" />
    <Parameter Name="EdgeStyleConfiguration_V100_53" Offset="0x50" Value="0x66" />
    <Parameter Name="EdgeLength_V100_53" Offset="0x51" Value="0x10" />
    <Parameter Name="ResidualAmplitudeLevel_V100_106" Offset="0x52" Value="0x00" />
    <Parameter Name="EdgeType_V100_106" Offset="0x53" Value="0x33" />
    <Parameter Name="EdgeStyleConfiguration_V100_106" Offset="0x54" Value="0x66" />
    <Parameter Name="EdgeLength_V100_106" Offset="0x55" Value="0x10" />
    <Parameter Name="ResidualAmplitudeLevel_V100_212" Offset="0x56" Value="0x00" />
    <Parameter Name="EdgeType_V100_212" Offset="0x57" Value="0x33" />
    <Parameter Name="EdgeStyleConfiguration_V100_212" Offset="0x58" Value="0x22" />
    <Parameter Name="EdgeLength_V100_212" Offset="0x59" Value="0x10" />
    <Parameter Name="ResidualAmplitudeLevel_V10_26" Offset="0x5A" Value="0xC0" />
    <Parameter Name="EdgeType_V10_26" Offset="0x5B" Value="0x22" />
    <Parameter Name="EdgeStyleConfiguration_V10_26" Offset="0x5C" Value="0x66" />
    <Parameter Name="EdgeLength_V10_26" Offset="0x5D" Value="0x10" />
    <Parameter Name="ResidualAmplitudeLevel_V10_53" Offset="0x5E" Value="0xC0" />
    <Parameter Name="EdgeType_V10_53" Offset="0x5F" Value="0x22" />
    <Parameter Name="EdgeStyleConfiguration_V10_53" Offset="0x60" Value="0x23" />
  </Region>

```

```

<Parameter Name="EdgeLength_V10_53" Offset="0x61" Value="0x10" />
<Parameter Name="ResidualAmplitudeLevel_V10_106" Offset="0x62" Value="0xC0" />
<Parameter Name="EdgeType_V10_106" Offset="0x63" Value="0x22" />
<Parameter Name="EdgeStyleConfiguration_V10_106" Offset="0x64" Value="0x23" />
<Parameter Name="EdgeLength_V10_106" Offset="0x65" Value="0x10" />
<Parameter Name="ResidualAmplitudeLevel_V10_212" Offset="0x66" Value="0xC0" />
<Parameter Name="EdgeType_V10_212" Offset="0x67" Value="0x22" />
<Parameter Name="EdgeStyleConfiguration_V10_212" Offset="0x68" Value="0x23" />
<Parameter Name="EdgeLength_V10_212" Offset="0x69" Value="0x10" />
<Parameter Name="ResidualAmplitudeLevel_180003m3_tari18p88" Offset="0x6A" Value="0xC0" />
<Parameter Name="EdgeType_180003m3_tari18p88" Offset="0x6B" Value="0x22" />
<Parameter Name="EdgeStyleConfiguration_180003m3_tari18p88" Offset="0x6C" Value="0x66" />
<Parameter Name="EdgeLength_180003m3_tari18p88" Offset="0x6D" Value="0x10" />
<Parameter Name="ResidualAmplitudeLevel_180003m3_tari9p44" Offset="0x6E" Value="0xC0" />
<Parameter Name="EdgeType_180003m3_tari9p44" Offset="0x6F" Value="0x22" />
<Parameter Name="EdgeStyleConfiguration_180003m3_tari9p44" Offset="0x70" Value="0x66" />
<Parameter Name="EdgeLength_180003m3_tari9p44" Offset="0x71" Value="0x10" />
<Parameter Name="ResidualAmplitudeLevel_B_prime106" Offset="0x72" Value="0xCF" />
<Parameter Name="EdgeType_B_prime106" Offset="0x73" Value="0x22" />
<Parameter Name="EdgeStyleConfiguration_B_prime106" Offset="0x74" Value="0x67" />
<Parameter Name="EdgeLength_B_prime106" Offset="0x75" Value="0x10" />
</Region>

<Region RegionName="DPC_SETTINGS" RegionAccess="RW" RegionType="DATA">
<Parameter Name="Config" Offset="0x76" Value="0x77" />
<Parameter Name="TargetCurrent" Offset="0x77" Value="0x0132" />
<Parameter Name="Hysteresis" Offset="0x79" Value="0x14" />
<Parameter Name="Hysteresis Unloading" Offset="0x7C" Value="0x0A" />
<Parameter Name="TXLDVDDPDLow" Offset="0x7D" Value="0x07" />
<Parameter Name="TXGSM" Offset="0x7E" Value="0x03" />
<Parameter Name="VDDPDLowLimitcontrol" Offset="0x7F" Value="0x01" />
<Parameter Name="InitialRDO_n_RFO_n" Offset="0x80" Value="0x03" />
<Parameter Name="GuardTimeBeforeTx" Offset="0x87" Value="0x64" />
<Parameter Name="EnableDPCduringFDT" Offset="0x88" Value="0x01" />
<Parameter Name="GuardTimeAfterRx" Offset="0x89" Value="0x01" />
<Parameter Name="Entry_00" Offset="0x8B" Value="0x0000137F" />
<Parameter Name="Entry_01" Offset="0x8F" Value="0x0000137F" />
<Parameter Name="Entry_02" Offset="0x93" Value="0x0000137F" />
<Parameter Name="Entry_03" Offset="0x97" Value="0x0000137F" />
<Parameter Name="Entry_04" Offset="0x9B" Value="0x0000137F" />
<Parameter Name="Entry_05" Offset="0x9F" Value="0x0000137F" />
<Parameter Name="Entry_06" Offset="0xA3" Value="0x0000007F" />
<Parameter Name="Entry_07" Offset="0xA7" Value="0x0000007F" />
<Parameter Name="Entry_08" Offset="0xAB" Value="0x0000007F" />
<Parameter Name="Entry_09" Offset="0xAF" Value="0x0000007F" />
<Parameter Name="Entry_10" Offset="0xB3" Value="0x0000007F" />
<Parameter Name="Entry_11" Offset="0xB7" Value="0x0000007F" />
<Parameter Name="Entry_12" Offset="0xBB" Value="0x0000007F" />
<Parameter Name="Entry_13" Offset="0xBF" Value="0x0000007F" />
<Parameter Name="Entry_14" Offset="0xC3" Value="0x0000007F" />
<Parameter Name="Entry_15" Offset="0xC7" Value="0x0000007F" />
<Parameter Name="Entry_16" Offset="0xCB" Value="0x0000007F" />
<Parameter Name="Entry_17" Offset="0xCF" Value="0x0000007F" />
<Parameter Name="Entry_18" Offset="0xD3" Value="0x0000007F" />
<Parameter Name="Entry_19" Offset="0xD7" Value="0x0000007F" />
<Parameter Name="Entry_20" Offset="0xDB" Value="0x0000007F" />
<Parameter Name="Entry_21" Offset="0xDF" Value="0x0000007F" />
<Parameter Name="Entry_22" Offset="0xE3" Value="0x0000007F" />
<Parameter Name="Entry_23" Offset="0xE7" Value="0x0000007D" />
<Parameter Name="Entry_24" Offset="0xEB" Value="0x0000007B" />
<Parameter Name="Entry_25" Offset="0xEF" Value="0x00000079" />
<Parameter Name="Entry_26" Offset="0xF3" Value="0x00000077" />
<Parameter Name="Entry_27" Offset="0xF7" Value="0x00000075" />
<Parameter Name="Entry_28" Offset="0xFB" Value="0x00000073" />
<Parameter Name="Entry_29" Offset="0xFF" Value="0x00000071" />
<Parameter Name="Entry_30" Offset="0x103" Value="0x0000006F" />
<Parameter Name="Entry_31" Offset="0x107" Value="0x0000006E" />
<Parameter Name="Entry_32" Offset="0x10B" Value="0x0000006C" />
<Parameter Name="Entry_33" Offset="0x10F" Value="0x0000006A" />
<Parameter Name="Entry_34" Offset="0x113" Value="0x00000068" />
<Parameter Name="Entry_35" Offset="0x117" Value="0x00000066" />
<Parameter Name="Entry_36" Offset="0x11B" Value="0x00000057" />
<Parameter Name="Entry_37" Offset="0x11F" Value="0x0000004B" />
<Parameter Name="Entry_38" Offset="0x123" Value="0x0000003F" />
<Parameter Name="Entry_39" Offset="0x127" Value="0x0000002D" />
<Parameter Name="Entry_40" Offset="0x12B" Value="0x00000000" />
<Parameter Name="Entry_41" Offset="0x12F" Value="0x00000000" />
<Parameter Name="Entry_42" Offset="0x133" Value="0x00000000" />
</Region>

<Region RegionName="ARC_SETTINGS" RegionAccess="RW" RegionType="DATA">
<Parameter Name="ArcConfig" Offset="0x137" Value="0x00E4" />
<Parameter Name="ArcVddpa" Offset="0x139" Value="0x2A24130E07" />
<Parameter Name="RmArcA_106" Offset="0x13E" Value="0x81348015802A8220C250" />
<Parameter Name="RmArcA_212" Offset="0x148" Value="0x001A00200030007F407E" />
<Parameter Name="RmArcA_424" Offset="0x152" Value="0x001A00200040007F407E" />
<Parameter Name="RmArcA_848" Offset="0x15C" Value="0x001A00200040007F407E" />
<Parameter Name="RmArcB_106" Offset="0x166" Value="0x001A0020003000404050" />
<Parameter Name="RmArcB_212" Offset="0x170" Value="0x001A002000400050407E" />
<Parameter Name="RmArcB_424" Offset="0x17A" Value="0x001A002000400050407E" />
<Parameter Name="RmArcB_848" Offset="0x184" Value="0x001A002000400050407E" />
<Parameter Name="RmArcF_212" Offset="0x18E" Value="0x001A00200040007F407E" />
<Parameter Name="RmArcF_424" Offset="0x198" Value="0x001A00200040007F407E" />
<Parameter Name="RmArcV_6p6" Offset="0x1A2" Value="0x000A000A000A000A400A" />
<Parameter Name="RmArcV_26" Offset="0x1AC" Value="0x000A000A002F002F402E" />
<Parameter Name="RmArcV_53" Offset="0x1B6" Value="0x001A010A011F011F411F" />
<Parameter Name="RmArcV_106" Offset="0x1C0" Value="0x000A000A002F002F402E" />
<Parameter Name="RmArcV_212" Offset="0x1CA" Value="0x000A000A002F002F402E" />
<Parameter Name="RmArc180003m3_SC424_4Man" Offset="0x1D4" Value="0x0114011F011F001F401F" />
<Parameter Name="RmArc180003m3_SC424_2Man" Offset="0x1DE" Value="0x0014001F003F004F404F" />
<Parameter Name="RmArc180003m3_SC848_4Man" Offset="0x1E8" Value="0x0114011F011F001F401F" />

```

```

<Parameter Name="RmArc180003m3_SC848_2Man" Offset="0x1F2" Value="0x0014001F003F004F404F" />
<Parameter Name="RmArc_AI_106" Offset="0x1FC" Value="0x000A000A000A000A400A" />
<Parameter Name="RmArc_AI_212" Offset="0x206" Value="0x000A000A000A000A400A" />
<Parameter Name="RmArc_AI_424" Offset="0x210" Value="0x000A000A000A000A400A" />
</Region>

<Region RegionName="RF_CLOCK_DLL_COM" RegionAccess="RW" RegionType="DATA">
<Parameter Name="DPLL_INIT_Default" Offset="0x2A6" Value="0x002D1327" />
<Parameter Name="DPLL_GEAR_Default" Offset="0x2AA" Value="0x04C1FEFE" />
<Parameter Name="DPLL_CONTROL" Offset="0x2AE" Value="0x00000C03" />
</Region>

<Region RegionName="AUTOCOLL_CFG" RegionAccess="RW" RegionType="DATA">
<Parameter Name="RfDebounceTimeout" Offset="0x2B2" Value="0x10" />
<Parameter Name="SensRes" Offset="0x2B3" Value="0x0042" />
<Parameter Name="NfcID1" Offset="0x2B5" Value="0xCCBBAA" />
<Parameter Name="SelRes" Offset="0x2B8" Value="0x60" />
<Parameter Name="PollRes" Offset="0x2B9" Value="0xFFD08584424B0B100814119814011401FE01" />
<Parameter Name="RandomUIDEnable" Offset="0x2CB" Value="0x00" />
</Region>

<Region RegionName="MFC_CFG" RegionAccess="RW" RegionType="DATA">
<Parameter Name="MfcAuthTimeout" Offset="0x2CC" Value="0x0500" />
</Region>

<Region RegionName="AFC_RSSI" RegionAccess="RW" RegionType="DATA">
<Parameter Name="RssiTimer" Offset="0x2DA" Value="0x0423" />
<Parameter Name="RssiTimerFirstPeriod" Offset="0x2DC" Value="0x013D" />
<Parameter Name="RssiCtrl_00_AB" Offset="0x2DE" Value="0x09" />
<Parameter Name="RssiNbEntriesAB" Offset="0x2DF" Value="0x16" />
<Parameter Name="RssiThresholdAB_01" Offset="0x2E0" Value="0x2816" />
<Parameter Name="ArbPhaseAB_01" Offset="0x2E2" Value="0x0000" />
<Parameter Name="RssiThresholdAB_02" Offset="0x2E4" Value="0x3215" />
<Parameter Name="ArbPhaseAB_02" Offset="0x2E6" Value="0x0000" />
<Parameter Name="RssiThresholdAB_03" Offset="0x2E8" Value="0x3B6E" />
<Parameter Name="ArbPhaseAB_03" Offset="0x2EA" Value="0x0000" />
<Parameter Name="RssiThresholdAB_04" Offset="0x2EC" Value="0x456A" />
<Parameter Name="ArbPhaseAB_04" Offset="0x2EE" Value="0x0000" />
<Parameter Name="RssiThresholdAB_05" Offset="0x2F0" Value="0x4FDC" />
<Parameter Name="ArbPhaseAB_05" Offset="0x2F2" Value="0x0000" />
<Parameter Name="RssiThresholdAB_06" Offset="0x2F4" Value="0x5983" />
<Parameter Name="ArbPhaseAB_06" Offset="0x2F6" Value="0x0000" />
<Parameter Name="RssiThresholdAB_07" Offset="0x2F8" Value="0x96F9" />
<Parameter Name="ArbPhaseAB_07" Offset="0x2FA" Value="0x0000" />
<Parameter Name="RssiThresholdAB_08" Offset="0x2FC" Value="0x96F9" />
<Parameter Name="ArbPhaseAB_08" Offset="0x2FE" Value="0x0000" />
<Parameter Name="RssiThresholdAB_09" Offset="0x300" Value="0x96F9" />
<Parameter Name="ArbPhaseAB_09" Offset="0x302" Value="0x0000" />
<Parameter Name="RssiThresholdAB_0A" Offset="0x304" Value="0x96F9" />
<Parameter Name="ArbPhaseAB_0A" Offset="0x306" Value="0x0000" />
<Parameter Name="RssiThresholdAB_0B" Offset="0x308" Value="0x96F9" />
<Parameter Name="ArbPhaseAB_0B" Offset="0x30A" Value="0x0000" />
<Parameter Name="RssiThresholdAB_0C" Offset="0x30C" Value="0x96F9" />
<Parameter Name="ArbPhaseAB_0C" Offset="0x30E" Value="0x0000" />
<Parameter Name="RssiThresholdAB_0D" Offset="0x310" Value="0x96F9" />
<Parameter Name="ArbPhaseAB_0D" Offset="0x312" Value="0x0000" />
<Parameter Name="RssiThresholdAB_0E" Offset="0x314" Value="0x96F9" />
<Parameter Name="ArbPhaseAB_0E" Offset="0x316" Value="0x0000" />
<Parameter Name="RssiThresholdAB_0F" Offset="0x318" Value="0x96F9" />
<Parameter Name="ArbPhaseAB_0F" Offset="0x31A" Value="0x0000" />
<Parameter Name="RssiThresholdAB_10" Offset="0x31C" Value="0x96F9" />
<Parameter Name="ArbPhaseAB_10" Offset="0x31E" Value="0x0000" />
<Parameter Name="RssiThresholdAB_11" Offset="0x320" Value="0x96F9" />
<Parameter Name="ArbPhaseAB_11" Offset="0x322" Value="0x0000" />
<Parameter Name="RssiThresholdAB_12" Offset="0x324" Value="0x96F9" />
<Parameter Name="ArbPhaseAB_12" Offset="0x326" Value="0x0000" />
<Parameter Name="RssiThresholdAB_13" Offset="0x328" Value="0x96F9" />
<Parameter Name="ArbPhaseAB_13" Offset="0x32A" Value="0x0000" />
<Parameter Name="RssiThresholdAB_14" Offset="0x32C" Value="0x96F9" />
<Parameter Name="ArbPhaseAB_14" Offset="0x32E" Value="0x0000" />
<Parameter Name="RssiThresholdAB_15" Offset="0x330" Value="0x96F9" />
<Parameter Name="ArbPhaseAB_15" Offset="0x332" Value="0x0000" />
<Parameter Name="RssiThresholdAB_16" Offset="0x334" Value="0x96F9" />
<Parameter Name="ArbPhaseAB_16" Offset="0x336" Value="0x0000" />
<Parameter Name="RssiThresholdAB_17" Offset="0x338" Value="0x96F9" />
<Parameter Name="ArbPhaseAB_17" Offset="0x33A" Value="0x0000" />
<Parameter Name="RssiThresholdAB_18" Offset="0x33C" Value="0x96F9" />
<Parameter Name="ArbPhaseAB_18" Offset="0x33E" Value="0x0000" />
<Parameter Name="RssiCtrl_00_F" Offset="0x340" Value="0x09" />
<Parameter Name="RssiNbEntriesF" Offset="0x341" Value="0x16" />
<Parameter Name="RssiThresholdF_01" Offset="0x342" Value="0x2816" />
<Parameter Name="ArbPhaseF_01" Offset="0x344" Value="0x0000" />
<Parameter Name="RssiThresholdF_02" Offset="0x346" Value="0x3215" />
<Parameter Name="ArbPhaseF_02" Offset="0x348" Value="0x0000" />
<Parameter Name="RssiThresholdF_03" Offset="0x34A" Value="0x3B6E" />
<Parameter Name="ArbPhaseF_03" Offset="0x34C" Value="0x0000" />
<Parameter Name="RssiThresholdF_04" Offset="0x34E" Value="0x456A" />
<Parameter Name="ArbPhaseF_04" Offset="0x350" Value="0x0000" />
<Parameter Name="RssiThresholdF_05" Offset="0x352" Value="0x4FDC" />
<Parameter Name="ArbPhaseF_05" Offset="0x354" Value="0x0000" />
<Parameter Name="RssiThresholdF_06" Offset="0x356" Value="0x5983" />
<Parameter Name="ArbPhaseF_06" Offset="0x358" Value="0x0000" />
<Parameter Name="RssiThresholdF_07" Offset="0x35A" Value="0x96F9" />
<Parameter Name="ArbPhaseF_07" Offset="0x35C" Value="0x0000" />
<Parameter Name="RssiThresholdF_08" Offset="0x35E" Value="0x96F9" />
<Parameter Name="ArbPhaseF_08" Offset="0x360" Value="0x0000" />
<Parameter Name="RssiThresholdF_09" Offset="0x362" Value="0x96F9" />
<Parameter Name="ArbPhaseF_09" Offset="0x364" Value="0x0000" />
<Parameter Name="RssiThresholdF_0A" Offset="0x366" Value="0x96F9" />
<Parameter Name="ArbPhaseF_0A" Offset="0x368" Value="0x0000" />
<Parameter Name="RssiThresholdF_0B" Offset="0x36A" Value="0x96F9" />

```

```

<Parameter Name="ArbPhaseF_0B" Offset="0x36C" Value="0x0000" />
<Parameter Name="RssiThresholdF_0C" Offset="0x36E" Value="0x96F9" />
<Parameter Name="ArbPhaseF_0C" Offset="0x370" Value="0x0000" />
<Parameter Name="RssiThresholdF_0D" Offset="0x372" Value="0x96F9" />
<Parameter Name="ArbPhaseF_0D" Offset="0x374" Value="0x0000" />
<Parameter Name="RssiThresholdF_0E" Offset="0x376" Value="0x96F9" />
<Parameter Name="ArbPhaseF_0E" Offset="0x378" Value="0x0000" />
<Parameter Name="RssiThresholdF_0F" Offset="0x37A" Value="0x96F9" />
<Parameter Name="ArbPhaseF_0F" Offset="0x37C" Value="0x0000" />
<Parameter Name="RssiThresholdF_10" Offset="0x37E" Value="0x96F9" />
<Parameter Name="ArbPhaseF_10" Offset="0x380" Value="0x0000" />
<Parameter Name="RssiThresholdF_11" Offset="0x382" Value="0x96F9" />
<Parameter Name="ArbPhaseF_11" Offset="0x384" Value="0x0000" />
<Parameter Name="RssiThresholdF_12" Offset="0x386" Value="0x96F9" />
<Parameter Name="ArbPhaseF_12" Offset="0x388" Value="0x0000" />
<Parameter Name="RssiThresholdF_13" Offset="0x38A" Value="0x96F9" />
<Parameter Name="ArbPhaseF_13" Offset="0x38C" Value="0x0000" />
<Parameter Name="RssiThresholdF_14" Offset="0x38E" Value="0x96F9" />
<Parameter Name="ArbPhaseF_14" Offset="0x390" Value="0x0000" />
<Parameter Name="RssiThresholdF_15" Offset="0x392" Value="0x96F9" />
<Parameter Name="ArbPhaseF_15" Offset="0x394" Value="0x0000" />
<Parameter Name="RssiThresholdF_16" Offset="0x396" Value="0x96F9" />
<Parameter Name="ArbPhaseF_16" Offset="0x398" Value="0x0000" />
<Parameter Name="RssiThresholdF_17" Offset="0x39A" Value="0x96F9" />
<Parameter Name="ArbPhaseF_17" Offset="0x39C" Value="0x0000" />
<Parameter Name="RssiThresholdF_18" Offset="0x39E" Value="0x96F9" />
<Parameter Name="ArbPhaseF_18" Offset="0x3A0" Value="0x0000" />
</Region>

<Region RegionName="APC_TX" RegionAccess="RW" RegionType="DATA">
<Parameter Name="TxParamEntry_00_ID" Offset="0x3A2" Value="0x40" />
<Parameter Name="TxParamEntry_00_Tx1" Offset="0x3A3" Value="0x00" />
<Parameter Name="TxParamEntry_00_Tx2" Offset="0x3A4" Value="0x64" />
<Parameter Name="TxParamEntry_01_ID" Offset="0x3A5" Value="0x41" />
<Parameter Name="TxParamEntry_01_Tx1" Offset="0x3A6" Value="0x00" />
<Parameter Name="TxParamEntry_01_Tx2" Offset="0x3A7" Value="0x64" />
<Parameter Name="TxParamEntry_02_ID" Offset="0x3A8" Value="0x42" />
<Parameter Name="TxParamEntry_02_Tx1" Offset="0x3A9" Value="0x00" />
<Parameter Name="TxParamEntry_02_Tx2" Offset="0x3AA" Value="0x64" />
<Parameter Name="TxParamEntry_03_ID" Offset="0x3AB" Value="0x43" />
<Parameter Name="TxParamEntry_03_Tx1" Offset="0x3AC" Value="0x00" />
<Parameter Name="TxParamEntry_03_Tx2" Offset="0x3AD" Value="0x64" />
<Parameter Name="TxParamEntry_04_ID" Offset="0x3AE" Value="0x44" />
<Parameter Name="TxParamEntry_04_Tx1" Offset="0x3AF" Value="0x00" />
<Parameter Name="TxParamEntry_04_Tx2" Offset="0x3B0" Value="0x64" />
<Parameter Name="TxParamEntry_05_ID" Offset="0x3B1" Value="0x45" />
<Parameter Name="TxParamEntry_05_Tx1" Offset="0x3B2" Value="0x00" />
<Parameter Name="TxParamEntry_05_Tx2" Offset="0x3B3" Value="0x64" />
<Parameter Name="TxParamEntry_06_ID" Offset="0x3B4" Value="0x46" />
<Parameter Name="TxParamEntry_06_Tx1" Offset="0x3B5" Value="0x00" />
<Parameter Name="TxParamEntry_06_Tx2" Offset="0x3B6" Value="0x64" />
<Parameter Name="TxParamEntry_07_ID" Offset="0x3B7" Value="0x47" />
<Parameter Name="TxParamEntry_07_Tx1" Offset="0x3B8" Value="0x00" />
<Parameter Name="TxParamEntry_07_Tx2" Offset="0x3B9" Value="0x64" />
<Parameter Name="TxParamEntry_08_ID" Offset="0x3BA" Value="0x48" />
<Parameter Name="TxParamEntry_08_Tx1" Offset="0x3BB" Value="0x00" />
<Parameter Name="TxParamEntry_08_Tx2" Offset="0x3BC" Value="0x64" />
<Parameter Name="TxParamEntry_09_ID" Offset="0x3BD" Value="0x49" />
<Parameter Name="TxParamEntry_09_Tx1" Offset="0x3BE" Value="0x00" />
<Parameter Name="TxParamEntry_09_Tx2" Offset="0x3BF" Value="0x64" />
<Parameter Name="TxParamEntry_0A_ID" Offset="0x3C0" Value="0x4A" />
<Parameter Name="TxParamEntry_0A_Tx1" Offset="0x3C1" Value="0x00" />
<Parameter Name="TxParamEntry_0A_Tx2" Offset="0x3C2" Value="0x64" />
<Parameter Name="TxParamEntry_0B_ID" Offset="0x3C3" Value="0x4B" />
<Parameter Name="TxParamEntry_0B_Tx1" Offset="0x3C4" Value="0x00" />
<Parameter Name="TxParamEntry_0B_Tx2" Offset="0x3C5" Value="0x64" />
<Parameter Name="TxParamEntry_0C_ID" Offset="0x3C6" Value="0x4C" />
<Parameter Name="TxParamEntry_00C_Tx1" Offset="0x3C7" Value="0x00" />
<Parameter Name="TxParamEntry_00C_Tx2" Offset="0x3C8" Value="0x64" />
<Parameter Name="TxParamEntry_0D_ID" Offset="0x3C9" Value="0x4D" />
<Parameter Name="TxParamEntry_0D_Tx1" Offset="0x3CA" Value="0x00" />
<Parameter Name="TxParamEntry_0D_Tx2" Offset="0x3CB" Value="0x64" />
<Parameter Name="TxParamEntry_0E_ID" Offset="0x3CC" Value="0x4E" />
<Parameter Name="TxParamEntry_0E_Tx1" Offset="0x3CD" Value="0x00" />
<Parameter Name="TxParamEntry_0E_Tx2" Offset="0x3CE" Value="0x64" />
<Parameter Name="TxParamEntry_0F_ID" Offset="0x3CF" Value="0x4F" />
<Parameter Name="TxParamEntry_0F_Tx1" Offset="0x3D0" Value="0x00" />
<Parameter Name="TxParamEntry_0F_Tx2" Offset="0x3D1" Value="0x64" />
<Parameter Name="TxParamEntry_10_ID" Offset="0x3D2" Value="0x50" />
<Parameter Name="TxParamEntry_10_Tx1" Offset="0x3D3" Value="0x00" />
<Parameter Name="TxParamEntry_10_Tx2" Offset="0x3D4" Value="0x64" />
<Parameter Name="TxParamEntry_11_ID" Offset="0x3D5" Value="0x51" />
<Parameter Name="TxParamEntry_11_Tx1" Offset="0x3D6" Value="0x00" />
<Parameter Name="TxParamEntry_11_Tx2" Offset="0x3D7" Value="0x64" />
<Parameter Name="TxParamEntry_12_ID" Offset="0x3D8" Value="0x52" />
<Parameter Name="TxParamEntry_12_Tx1" Offset="0x3D9" Value="0x00" />
<Parameter Name="TxParamEntry_12_Tx2" Offset="0x3DA" Value="0x64" />
<Parameter Name="TxParamEntry_13_ID" Offset="0x3DB" Value="0x53" />
<Parameter Name="TxParamEntry_13_Tx1" Offset="0x3DC" Value="0x00" />
<Parameter Name="TxParamEntry_13_Tx2" Offset="0x3DD" Value="0x64" />
<Parameter Name="TxParamEntry_14_ID" Offset="0x3DE" Value="0x54" />
<Parameter Name="TxParamEntry_14_Tx1" Offset="0x3DF" Value="0x00" />
<Parameter Name="TxParamEntry_14_Tx2" Offset="0x3E0" Value="0x64" />
<Parameter Name="TxParamEntry_15_ID" Offset="0x3E1" Value="0x55" />
<Parameter Name="TxParamEntry_15_Tx1" Offset="0x3E2" Value="0x00" />
<Parameter Name="TxParamEntry_15_Tx2" Offset="0x3E3" Value="0x64" />
<Parameter Name="TxParamEntry_16_ID" Offset="0x3E4" Value="0x56" />
<Parameter Name="TxParamEntry_16_Tx1" Offset="0x3E5" Value="0x00" />
<Parameter Name="TxParamEntry_16_Tx2" Offset="0x3E6" Value="0x64" />
<Parameter Name="TxParamEntry_17_ID" Offset="0x3E7" Value="0x57" />
<Parameter Name="TxParamEntry_17_Tx1" Offset="0x3E8" Value="0x00" />

```



```

<Parameter Name="TxParamEntry_39_Tx1" Offset="0x44E" Value="0x00" />
<Parameter Name="TxParamEntry_39_Tx2" Offset="0x44F" Value="0x37" />
<Parameter Name="TxParamEntry_3A_ID" Offset="0x450" Value="0x7A" />
<Parameter Name="TxParamEntry_3A_Tx1" Offset="0x451" Value="0x00" />
<Parameter Name="TxParamEntry_3A_Tx2" Offset="0x452" Value="0x37" />
<Parameter Name="TxParamEntry_3B_ID" Offset="0x453" Value="0x7B" />
<Parameter Name="TxParamEntry_3B_Tx1" Offset="0x454" Value="0x00" />
<Parameter Name="TxParamEntry_3B_Tx2" Offset="0x455" Value="0x37" />
<Parameter Name="TxParamEntry_3C_ID" Offset="0x456" Value="0x7C" />
<Parameter Name="TxParamEntry_3C_Tx1" Offset="0x457" Value="0x00" />
<Parameter Name="TxParamEntry_3C_Tx2" Offset="0x458" Value="0x37" />
<Parameter Name="TxParamEntry_3D_ID" Offset="0x459" Value="0x7D" />
<Parameter Name="TxParamEntry_3D_Tx1" Offset="0x45A" Value="0x00" />
<Parameter Name="TxParamEntry_3D_Tx2" Offset="0x45B" Value="0x37" />
<Parameter Name="TxParamEntry_3E_ID" Offset="0x45C" Value="0x7E" />
<Parameter Name="TxParamEntry_3E_Tx1" Offset="0x45D" Value="0x00" />
<Parameter Name="TxParamEntry_3E_Tx2" Offset="0x45E" Value="0x37" />
<Parameter Name="TxParamEntry_3F_ID" Offset="0x45F" Value="0x7F" />
<Parameter Name="TxParamEntry_3F_Tx1" Offset="0x460" Value="0x00" />
<Parameter Name="TxParamEntry_3F_Tx2" Offset="0x461" Value="0x37" />
<Parameter Name="TxParamEntry_40_ID" Offset="0x462" Value="0x7E" />
<Parameter Name="TxParamEntry_40_Tx1" Offset="0x463" Value="0x00" />
<Parameter Name="TxParamEntry_40_Tx2" Offset="0x464" Value="0x37" />
<Parameter Name="TxParamEntry_41_ID" Offset="0x465" Value="0x7F" />
<Parameter Name="TxParamEntry_41_Tx1" Offset="0x466" Value="0x00" />
<Parameter Name="TxParamEntry_41_Tx2" Offset="0x467" Value="0x37" />
<Parameter Name="TxParamEntry_42_ID" Offset="0x468" Value="0x7E" />
<Parameter Name="TxParamEntry_42_Tx1" Offset="0x469" Value="0x00" />
<Parameter Name="TxParamEntry_42_Tx2" Offset="0x46A" Value="0x37" />
<Parameter Name="TxParamEntry_43_ID" Offset="0x46B" Value="0x7F" />
<Parameter Name="TxParamEntry_43_Tx1" Offset="0x46C" Value="0x00" />
<Parameter Name="TxParamEntry_43_Tx2" Offset="0x46D" Value="0x37" />
<Parameter Name="TxParamEntry_44_ID" Offset="0x46E" Value="0x7E" />
<Parameter Name="TxParamEntry_44_Tx1" Offset="0x46F" Value="0x00" />
<Parameter Name="TxParamEntry_44_Tx2" Offset="0x470" Value="0x37" />
<Parameter Name="TxParamEntry_45_ID" Offset="0x471" Value="0x7F" />
<Parameter Name="TxParamEntry_45_Tx1" Offset="0x472" Value="0x00" />
<Parameter Name="TxParamEntry_45_Tx2" Offset="0x473" Value="0x37" />
<Parameter Name="TxParamEntry_46_ID" Offset="0x474" Value="0x7E" />
<Parameter Name="TxParamEntry_46_Tx1" Offset="0x475" Value="0x00" />
<Parameter Name="TxParamEntry_46_Tx2" Offset="0x476" Value="0x37" />
<Parameter Name="TxParamEntry_47_ID" Offset="0x477" Value="0x7F" />
<Parameter Name="TxParamEntry_47_Tx1" Offset="0x478" Value="0x00" />
<Parameter Name="TxParamEntry_47_Tx2" Offset="0x479" Value="0x37" />
<Parameter Name="TxParamEntry_48_ID" Offset="0x47A" Value="0x7E" />
<Parameter Name="TxParamEntry_48_Tx1" Offset="0x47B" Value="0x00" />
<Parameter Name="TxParamEntry_48_Tx2" Offset="0x47C" Value="0x37" />
<Parameter Name="TxParamEntry_49_ID" Offset="0x47D" Value="0x7F" />
<Parameter Name="TxParamEntry_49_Tx1" Offset="0x47E" Value="0x00" />
<Parameter Name="TxParamEntry_49_Tx2" Offset="0x47F" Value="0x37" />
<Parameter Name="TxParamEntry_4A_ID" Offset="0x480" Value="0x7E" />
<Parameter Name="TxParamEntry_4A_Tx1" Offset="0x481" Value="0x00" />
<Parameter Name="TxParamEntry_4A_Tx2" Offset="0x482" Value="0x37" />
<Parameter Name="TxParamEntry_4B_ID" Offset="0x483" Value="0x7F" />
<Parameter Name="TxParamEntry_4B_Tx1" Offset="0x484" Value="0x00" />
<Parameter Name="TxParamEntry_4B_Tx2" Offset="0x485" Value="0x37" />
<Parameter Name="TxParamEntry_4C_ID" Offset="0x486" Value="0x7E" />
<Parameter Name="TxParamEntry_4C_Tx1" Offset="0x487" Value="0x00" />
<Parameter Name="TxParamEntry_4C_Tx2" Offset="0x488" Value="0x37" />
<Parameter Name="TxParamEntry_4D_ID" Offset="0x489" Value="0x7F" />
<Parameter Name="TxParamEntry_4D_Tx1" Offset="0x48A" Value="0x00" />
<Parameter Name="TxParamEntry_4D_Tx2" Offset="0x48B" Value="0x37" />
<Parameter Name="TxParamEntry_4E_ID" Offset="0x48C" Value="0x7E" />
<Parameter Name="TxParamEntry_4E_Tx1" Offset="0x48D" Value="0x00" />
<Parameter Name="TxParamEntry_4E_Tx2" Offset="0x48E" Value="0x37" />
<Parameter Name="dummy" Offset="0x48F" Value="0x000000" />
</Region>

<Region RegionName="LPCD_SETTINGS" RegionAccess="RW" RegionType="DATA">
<Parameter Name="avg_samples" Offset="0x492" Value="0x06" />
<Parameter Name="lpcd_rssi_target" Offset="0x494" Value="0x02A3" />
<Parameter Name="lpcd_rssi_hyst" Offset="0x496" Value="0x1F" />
<Parameter Name="Config" Offset="0x497" Value="0x003B" />
<Parameter Name="lpcd_threshold_coarse" Offset="0x49A" Value="0x00500050" />
<Parameter Name="lpcd_threshold_fine" Offset="0x49E" Value="0x7FFF7FFF" />
</Region>

<Region RegionName="ULPCD_CONFIG" RegionAccess="RW" RegionType="DATA">
<Parameter Name="Voltage_Ctrl" Offset="0x4C6" Value="0x6A" />
</Region>

<Region RegionName="ULPCD_SETTINGS" RegionAccess="RW" RegionType="DATA">
<Parameter Name="rssi_nsp" Offset="0x4C9" Value="0x10" />
<Parameter Name="rssi_no_samples" Offset="0x4CA" Value="0x00" />
<Parameter Name="thresh_ivl" Offset="0x4CB" Value="0x0C" />
<Parameter Name="polarity" Offset="0x4CC" Value="0x01" />
</Region>

<Region RegionName="TXIRQ_GUARD" RegionAccess="RW" RegionType="DATA">
<Parameter Name="TXIRQ_GuardTime" Offset="0x559" Value="0x000FFFFFF" />
</Region>

<Region RegionName="FDT_DEFAULT" RegionAccess="RW" RegionType="DATA">
<Parameter Name="FDT_DefaultVal" Offset="0x55D" Value="0x000472AC" />
</Region>

<Region RegionName="RXIRQ_GUARD" RegionAccess="RW" RegionType="DATA">
<Parameter Name="RXIRQ_GuardTime" Offset="0x561" Value="0x000F4240" />
</Region>

<Region RegionName="TX_SHAPING_PROPRIETARY_CORR" RegionAccess="RW" RegionType="DATA">

```

```

<Parameter Name="Correction_Entry0" Offset="0xBAD" Value="0x0000" />
<Parameter Name="Correction_Entry1" Offset="0xBAF" Value="0x0000" />
<Parameter Name="Correction_Entry2" Offset="0xBB1" Value="0x0000" />
<Parameter Name="Correction_Entry3" Offset="0xBB3" Value="0x0000" />
<Parameter Name="Correction_Entry4" Offset="0xBB5" Value="0x0000" />
<Parameter Name="Correction_Entry5" Offset="0xBB7" Value="0x0000" />
<Parameter Name="Correction_Entry6" Offset="0xBB9" Value="0x0000" />
<Parameter Name="Correction_Entry7" Offset="0xBBB" Value="0x0000" />
<Parameter Name="Correction_Entry8" Offset="0xBBD" Value="0x0000" />
<Parameter Name="Correction_Entry9" Offset="0xBBF" Value="0x0000" />
<Parameter Name="Correction_Entry10" Offset="0xBC1" Value="0x0000" />
<Parameter Name="Correction_Entry11" Offset="0xBC3" Value="0x0000" />
<Parameter Name="Correction_Entry12" Offset="0xBC5" Value="0x0000" />
<Parameter Name="Correction_Entry13" Offset="0xBC7" Value="0x0000" />
<Parameter Name="Correction_Entry14" Offset="0xBC9" Value="0x0000" />
<Parameter Name="Correction_Entry15" Offset="0xBCE" Value="0x0000" />
<Parameter Name="Correction_Entry16" Offset="0xBCE" Value="0x0000" />
<Parameter Name="Correction_Entry17" Offset="0xBCF" Value="0x0000" />
<Parameter Name="Correction_Entry18" Offset="0xBD1" Value="0x0000" />
<Parameter Name="Correction_Entry19" Offset="0xBD3" Value="0x0000" />
<Parameter Name="Correction_Entry20" Offset="0xBD5" Value="0x0000" />
<Parameter Name="Correction_Entry21" Offset="0xBD7" Value="0x0000" />
<Parameter Name="Correction_Entry22" Offset="0xBD9" Value="0x0000" />
<Parameter Name="Correction_Entry23" Offset="0xBDB" Value="0x0000" />
<Parameter Name="Correction_Entry24" Offset="0xBDD" Value="0x0000" />
<Parameter Name="Correction_Entry25" Offset="0xBDE" Value="0x0000" />
<Parameter Name="Correction_Entry26" Offset="0xBE1" Value="0x0000" />
<Parameter Name="Correction_Entry27" Offset="0xBE3" Value="0x0000" />
<Parameter Name="Correction_Entry28" Offset="0xBE5" Value="0x0000" />
<Parameter Name="Correction_Entry29" Offset="0xBE7" Value="0x0000" />
<Parameter Name="Correction_Entry30" Offset="0xBE9" Value="0x0000" />
<Parameter Name="Correction_Entry31" Offset="0xBEB" Value="0x0000" />
<Parameter Name="Correction_Entry32" Offset="0xBED" Value="0x0000" />
<Parameter Name="Correction_Entry33" Offset="0xBEF" Value="0x0000" />
<Parameter Name="Correction_Entry34" Offset="0xBF1" Value="0x0000" />
<Parameter Name="Correction_Entry35" Offset="0xBF3" Value="0x0000" />
<Parameter Name="Correction_Entry36" Offset="0xBF5" Value="0x0000" />
<Parameter Name="Correction_Entry37" Offset="0xBF7" Value="0x0000" />
<Parameter Name="Correction_Entry38" Offset="0xBF9" Value="0x0000" />
<Parameter Name="Correction_Entry39" Offset="0xBF9" Value="0x0000" />
<Parameter Name="Correction_Entry40" Offset="0xBFD" Value="0x0000" />
<Parameter Name="Correction_Entry41" Offset="0xBFF" Value="0x0000" />
<Parameter Name="Correction_Entry42" Offset="0xC01" Value="0x0000" />
</Region>

<Region RegionName="TX_SHAPING_PROPRIETARY_1" RegionAccess="RW" RegionType="DATA">
  <Parameter Name="RTRANS0" Offset="0xC03" Value="0xDFD9D3CD" />
  <Parameter Name="RTRANS1" Offset="0xC07" Value="0xF1EEEBE5" />
  <Parameter Name="RTRANS2" Offset="0xC0B" Value="0xFDFAF7F4" />
  <Parameter Name="RTRANS3" Offset="0xC0F" Value="0xFFFFFFFF" />
  <Parameter Name="FTRANS0" Offset="0xC13" Value="0xE7EDF3F9" />
  <Parameter Name="FTRANS1" Offset="0xC17" Value="0xD4D8DBE1" />
  <Parameter Name="FTRANS2" Offset="0xC1B" Value="0xC8CACDD1" />
  <Parameter Name="FTRANS3" Offset="0xC1F" Value="0xC7C7C7C7" />
</Region>

<Region RegionName="TX_SHAPING_PROPRIETARY_2" RegionAccess="RW" RegionType="DATA">
  <Parameter Name="RTRANS0" Offset="0xC23" Value="0xF0EAE3DA" />
  <Parameter Name="RTRANS1" Offset="0xC27" Value="0xFAF9F6F4" />
  <Parameter Name="RTRANS2" Offset="0xC2B" Value="0xFEFDFFDF" />
  <Parameter Name="RTRANS3" Offset="0xC2F" Value="0xFFFFFFFF" />
  <Parameter Name="FTRANS0" Offset="0xC33" Value="0xFEFFFFFF" />
  <Parameter Name="FTRANS1" Offset="0xC37" Value="0xFCFDFDFE" />
  <Parameter Name="FTRANS2" Offset="0xC3B" Value="0xF4F6F9FA" />
  <Parameter Name="FTRANS3" Offset="0xC3F" Value="0xDAE3EAF0" />
</Region>

<Region RegionName="TX_SHAPING_PROPRIETARY_3" RegionAccess="RW" RegionType="DATA">
  <Parameter Name="RTRANS0" Offset="0xC43" Value="0x00000000" />
  <Parameter Name="RTRANS1" Offset="0xC47" Value="0x00000000" />
  <Parameter Name="RTRANS2" Offset="0xC4B" Value="0x00000000" />
  <Parameter Name="RTRANS3" Offset="0xC4F" Value="0x00000000" />
  <Parameter Name="FTRANS0" Offset="0xC53" Value="0x00000000" />
  <Parameter Name="FTRANS1" Offset="0xC57" Value="0x00000000" />
  <Parameter Name="FTRANS2" Offset="0xC5B" Value="0x00000000" />
  <Parameter Name="FTRANS3" Offset="0xC5F" Value="0x00000000" />
</Region>

<Region RegionName="TX_SHAPING_PROPRIETARY_4" RegionAccess="RW" RegionType="DATA">
  <Parameter Name="RTRANS0" Offset="0xC63" Value="0x00000000" />
  <Parameter Name="RTRANS1" Offset="0xC67" Value="0x00000000" />
  <Parameter Name="RTRANS2" Offset="0xC6B" Value="0x00000000" />
  <Parameter Name="RTRANS3" Offset="0xC6F" Value="0x00000000" />
  <Parameter Name="FTRANS0" Offset="0xC73" Value="0x00000000" />
  <Parameter Name="FTRANS1" Offset="0xC77" Value="0x00000000" />
  <Parameter Name="FTRANS2" Offset="0xC7B" Value="0x00000000" />
  <Parameter Name="FTRANS3" Offset="0xC7F" Value="0x00000000" />
</Region>

<Region RegionName="TX_DRIVER_NOV" RegionAccess="RW" RegionType="DATA">
  <Parameter Name="CfIgNovCal" Offset="0xC83" Value="0x42" />
  <Parameter Name="VddpaCalVal1" Offset="0xC84" Value="0x03" />
  <Parameter Name="VddpaCalVal2" Offset="0xC85" Value="0x15" />
  <Parameter Name="CfIgThreshold" Offset="0xC86" Value="0x08" />
  <Parameter Name="UserOffsets1" Offset="0xC87" Value="0x8A0A0C00" />
  <Parameter Name="UserOffsets2" Offset="0xC8B" Value="0x09080D03" />
</Region>

<Region RegionName="USER_PMU_INT_1" RegionAccess="RW" RegionType="DATA">
  <Parameter Name="EnableFastVDDPDischarge" Offset="0xC8F" Value="0x00" />
</Region>

```



```

<Register RegisterName="CLIF_DGRM_HF_ATT" RegisterLogicalAddress="0x2F" RegisterValue="0x00000000"></Register>
<Register RegisterName="CLIF_DGRM_RSSI" RegisterLogicalAddress="0x30" RegisterValue="0x00000000"></Register>
<Register RegisterName="CLIF_SIGPRO_RM_TECH" RegisterLogicalAddress="0x22" RegisterValue="0x00000003"></Register>
<Register RegisterName="CLIF_SIGPRO_CM_CONFIG" RegisterLogicalAddress="0x37" RegisterValue="0x20060200"></Register>
</Protocol>
<Protocol ProtocolName="RX_GTM_All" ProtocolIndex="0x9C" ProtocolOffset="0x1226">
<Register RegisterName="CLIF_ANA_RX_CTRL" RegisterLogicalAddress="0x43" RegisterValue="0x0700E437"></Register>
<Register RegisterName="CLIF_DCOC_CONFIG" RegisterLogicalAddress="0x33" RegisterValue="0x00100032"></Register>
<Register RegisterName="CLIF_RXM_CTRL" RegisterLogicalAddress="0x35" RegisterValue="0x0004C935"></Register>
<Register RegisterName="CLIF_GCM_CONFIG2" RegisterLogicalAddress="0x38" RegisterValue="0x00A24820"></Register>
<Register RegisterName="CLIF_GCM_CONFIG1" RegisterLogicalAddress="0x39" RegisterValue="0x4000003F"></Register>
<Register RegisterName="CLIF_GCM_CONFIG0" RegisterLogicalAddress="0x3A" RegisterValue="0x00A93979"></Register>
<Register RegisterName="CLIF_ANA_AGC_DCO_CTRL" RegisterLogicalAddress="0x36" RegisterValue="0x00000000"></Register>
<Register RegisterName="CLIF_SIGPRO_RM_CONFIG" RegisterLogicalAddress="0x1F" RegisterValue="0x00000000"></Register>
<Register RegisterName="CLIF_SIGPRO_RM_ENABLES" RegisterLogicalAddress="0x21" RegisterValue="0x00000000"></Register>
<Register RegisterName="CLIF_SIGPRO_CONFIG" RegisterLogicalAddress="0x1D" RegisterValue="0x00600081"></Register>
<Register RegisterName="CLIF_SIGPRO_NOISE_CONFIG1" RegisterLogicalAddress="0x23" RegisterValue="0x00000000"></Register>
<Register RegisterName="CLIF_SIGPRO_NOISE_CONFIG2" RegisterLogicalAddress="0x24" RegisterValue="0x00000000"></Register>
<Register RegisterName="CLIF_RX_ERROR_CONFIG" RegisterLogicalAddress="0x27" RegisterValue="0x000037FF"></Register>
<Register RegisterName="CLIF_RX_EMD_0_CONFIG" RegisterLogicalAddress="0x48" RegisterValue="0x00280200"></Register>
<Register RegisterName="CLIF_SIGPRO_IIR_CONFIG1" RegisterLogicalAddress="0x29" RegisterValue="0x00000000"></Register>
<Register RegisterName="CLIF_SIGPRO_IIR_CONFIG0" RegisterLogicalAddress="0x2A" RegisterValue="0x00000000"></Register>
<Register RegisterName="CLIF_DGRM_DAC_FILTER" RegisterLogicalAddress="0x2B" RegisterValue="0x00000000"></Register>
<Register RegisterName="CLIF_DGRM_CONFIG" RegisterLogicalAddress="0x2C" RegisterValue="0x00000000"></Register>
<Register RegisterName="CLIF_DGRM_BBA" RegisterLogicalAddress="0x2D" RegisterValue="0x00000000"></Register>
<Register RegisterName="CLIF_DGRM_DCO" RegisterLogicalAddress="0x2E" RegisterValue="0x00000000"></Register>
<Register RegisterName="CLIF_DGRM_HF_ATT" RegisterLogicalAddress="0x2F" RegisterValue="0x00000000"></Register>
<Register RegisterName="CLIF_DGRM_RSSI" RegisterLogicalAddress="0x30" RegisterValue="0x00000000"></Register>
<Register RegisterName="CLIF_SIGPRO_RM_TECH" RegisterLogicalAddress="0x22" RegisterValue="0x00000003"></Register>
<Register RegisterName="CLIF_SIGPRO_CM_CONFIG" RegisterLogicalAddress="0x37" RegisterValue="0xBF9600A0"></Register>
</Protocol>
<Protocol ProtocolName="RX_B_Prime_All" ProtocolIndex="0x9D" ProtocolOffset="0x129E">
<Register RegisterName="CLIF_ANA_RX_CTRL" RegisterLogicalAddress="0x43" RegisterValue="0x0000E407"></Register>
<Register RegisterName="CLIF_DCOC_CONFIG" RegisterLogicalAddress="0x33" RegisterValue="0x000000F4"></Register>
<Register RegisterName="CLIF_RXM_CTRL" RegisterLogicalAddress="0x35" RegisterValue="0x0044893E"></Register>
<Register RegisterName="CLIF_GCM_CONFIG2" RegisterLogicalAddress="0x38" RegisterValue="0x00024820"></Register>
<Register RegisterName="CLIF_GCM_CONFIG1" RegisterLogicalAddress="0x39" RegisterValue="0x00000FC0"></Register>
<Register RegisterName="CLIF_GCM_CONFIG0" RegisterLogicalAddress="0x3A" RegisterValue="0x00D03939"></Register>
<Register RegisterName="CLIF_ANA_AGC_DCO_CTRL" RegisterLogicalAddress="0x36" RegisterValue="0x01000008"></Register>
<Register RegisterName="CLIF_SIGPRO_RM_CONFIG" RegisterLogicalAddress="0x1F" RegisterValue="0x02380248"></Register>
<Register RegisterName="CLIF_SIGPRO_RM_ENABLES" RegisterLogicalAddress="0x21" RegisterValue="0x00000055"></Register>
<Register RegisterName="CLIF_SIGPRO_CONFIG" RegisterLogicalAddress="0x1D" RegisterValue="0x400000BE"></Register>
<Register RegisterName="CLIF_SIGPRO_NOISE_CONFIG1" RegisterLogicalAddress="0x23" RegisterValue="0x0C082155"></Register>
<Register RegisterName="CLIF_SIGPRO_NOISE_CONFIG2" RegisterLogicalAddress="0x24" RegisterValue="0x00085510"></Register>
<Register RegisterName="CLIF_RX_ERROR_CONFIG" RegisterLogicalAddress="0x27" RegisterValue="0x00003FFF"></Register>
<Register RegisterName="CLIF_RX_EMD_0_CONFIG" RegisterLogicalAddress="0x48" RegisterValue="0x1F200000"></Register>
<Register RegisterName="CLIF_SIGPRO_IIR_CONFIG1" RegisterLogicalAddress="0x29" RegisterValue="0x01B0618E"></Register>
<Register RegisterName="CLIF_SIGPRO_IIR_CONFIG0" RegisterLogicalAddress="0x2A" RegisterValue="0x0000A85C"></Register>
<Register RegisterName="CLIF_DGRM_DAC_FILTER" RegisterLogicalAddress="0x2B" RegisterValue="0x00889238"></Register>
<Register RegisterName="CLIF_DGRM_CONFIG" RegisterLogicalAddress="0x2C" RegisterValue="0x00E63400"></Register>
<Register RegisterName="CLIF_DGRM_BBA" RegisterLogicalAddress="0x2D" RegisterValue="0xED4C64A4"></Register>
<Register RegisterName="CLIF_DGRM_DCO" RegisterLogicalAddress="0x2E" RegisterValue="0xC0F7C1F0"></Register>
<Register RegisterName="CLIF_DGRM_HF_ATT" RegisterLogicalAddress="0x2F" RegisterValue="0x2A8FFFFFF"></Register>
<Register RegisterName="CLIF_DGRM_RSSI" RegisterLogicalAddress="0x30" RegisterValue="0x393F518A"></Register>
<Register RegisterName="CLIF_SIGPRO_RM_TECH" RegisterLogicalAddress="0x22" RegisterValue="0x95086250"></Register>
<Register RegisterName="CLIF_SIGPRO_CM_CONFIG" RegisterLogicalAddress="0x37" RegisterValue="0x1FE00001"></Register>
</Protocol>
</Region>
</EEPROM>

```

19 Appendix: EEPROM_LOAD_RF_CONFIGURATION FW2.1

Firmware 2.1

```
<?xml version="1.0" encoding="utf-8"?>
<EEPROM>
  <Region RegionName="USER_PMU" RegionAccess="RW" RegionType="DATA">
    <Parameter Name="PwrConfig" Offset="0x00" Value="0xE4" />
    <Parameter Name="DcdcConfig" Offset="0x01" Value="0x31" />
    <Parameter Name="TxLdoConfig" Offset="0x02" Value="0xFFFFAE7" />
    <Parameter Name="TxLdoVddpaHigh" Offset="0x06" Value="0x00" />
    <Parameter Name="TxLdoVddpaLow" Offset="0x07" Value="0x00" />
    <Parameter Name="TxLdoVddpaMaxRdr" Offset="0x08" Value="0x2A" />
    <Parameter Name="TxLdoVddpaMaxCard" Offset="0x09" Value="0x2A" />
    <Parameter Name="BoostDefaultVoltage" Offset="0x0A" Value="0x1D" />
  </Region>
  <Region RegionName="CLKGEN" RegionAccess="RW" RegionType="DATA">
    <Parameter Name="XtalConfig" Offset="0x10" Value="0x00" />
    <Parameter Name="XtalTimeOut" Offset="0x11" Value="0xFF" />
  </Region>
  <Region RegionName="RF_CLOCK_CFG" RegionAccess="RW" RegionType="DATA">
    <Parameter Name="PLLClkInputFrq" Offset="0x12" Value="0x08" />
    <Parameter Name="XtalCheckDelay" Offset="0x13" Value="0xF6" />
  </Region>
  <Region RegionName="USER_SMU" RegionAccess="RW" RegionType="DATA">
    <Parameter Name="TempWarning" Offset="0x14" Value="0x99" />
    <Parameter Name="EnableGpio0OnOverTemp" Offset="0x16" Value="0x01" />
  </Region>
  <Region RegionName="RM_TECHNO_TX_SHAPING" RegionAccess="RW" RegionType="DATA">
    <Parameter Name="ResidualAmplitudeLevel_A106" Offset="0x22" Value="0x00" />
    <Parameter Name="EdgeType_A106" Offset="0x23" Value="0x33" />
    <Parameter Name="EdgeStyleConfiguration_A106" Offset="0x24" Value="0x64" />
    <Parameter Name="EdgeLength_A106" Offset="0x25" Value="0x10" />
    <Parameter Name="ResidualAmplitudeLevel_A212" Offset="0x26" Value="0x00" />
    <Parameter Name="EdgeType_A212" Offset="0x27" Value="0x33" />
    <Parameter Name="EdgeStyleConfiguration_A212" Offset="0x28" Value="0x44" />
    <Parameter Name="EdgeLength_A212" Offset="0x29" Value="0x10" />
    <Parameter Name="ResidualAmplitudeLevel_A424" Offset="0x2A" Value="0x00" />
    <Parameter Name="EdgeType_A424" Offset="0x2B" Value="0x33" />
    <Parameter Name="EdgeStyleConfiguration_A424" Offset="0x2C" Value="0x24" />
    <Parameter Name="EdgeLength_A424" Offset="0x2D" Value="0x10" />
    <Parameter Name="ResidualAmplitudeLevel_A848" Offset="0x2E" Value="0x00" />
    <Parameter Name="EdgeType_A848" Offset="0x2F" Value="0x11" />
    <Parameter Name="EdgeStyleConfiguration_A848" Offset="0x30" Value="0x18" />
    <Parameter Name="EdgeLength_A848" Offset="0x31" Value="0x10" />
    <Parameter Name="ResidualAmplitudeLevel_B106" Offset="0x32" Value="0xCA" />
    <Parameter Name="EdgeType_B106" Offset="0x33" Value="0x44" />
    <Parameter Name="EdgeStyleConfiguration_B106" Offset="0x34" Value="0x00" />
    <Parameter Name="EdgeLength_B106" Offset="0x35" Value="0x10" />
    <Parameter Name="ResidualAmplitudeLevel_B212" Offset="0x36" Value="0xCF" />
    <Parameter Name="EdgeType_B212" Offset="0x37" Value="0x22" />
    <Parameter Name="EdgeStyleConfiguration_B212" Offset="0x38" Value="0x66" />
    <Parameter Name="EdgeLength_B212" Offset="0x39" Value="0x10" />
    <Parameter Name="ResidualAmplitudeLevel_B424" Offset="0x3A" Value="0xCF" />
    <Parameter Name="EdgeType_B424" Offset="0x3B" Value="0x22" />
    <Parameter Name="EdgeStyleConfiguration_B424" Offset="0x3C" Value="0x55" />
    <Parameter Name="EdgeLength_B424" Offset="0x3D" Value="0x10" />
    <Parameter Name="ResidualAmplitudeLevel_B848" Offset="0x3E" Value="0xCE" />
    <Parameter Name="EdgeType_B848" Offset="0x3F" Value="0x22" />
    <Parameter Name="EdgeStyleConfiguration_B848" Offset="0x40" Value="0x34" />
    <Parameter Name="EdgeLength_B848" Offset="0x41" Value="0x10" />
    <Parameter Name="ResidualAmplitudeLevel_F212" Offset="0x42" Value="0xCF" />
    <Parameter Name="EdgeType_F212" Offset="0x43" Value="0x22" />
    <Parameter Name="EdgeStyleConfiguration_F212" Offset="0x44" Value="0x65" />
    <Parameter Name="EdgeLength_F212" Offset="0x45" Value="0x10" />
    <Parameter Name="ResidualAmplitudeLevel_F424" Offset="0x46" Value="0xCE" />
    <Parameter Name="EdgeType_F424" Offset="0x47" Value="0x22" />
    <Parameter Name="EdgeStyleConfiguration_F424" Offset="0x48" Value="0x55" />
    <Parameter Name="EdgeLength_F424" Offset="0x49" Value="0x10" />
    <Parameter Name="ResidualAmplitudeLevel_V100_26" Offset="0x4A" Value="0x00" />
    <Parameter Name="EdgeType_V100_26" Offset="0x4B" Value="0x33" />
    <Parameter Name="EdgeStyleConfiguration_V100_26" Offset="0x4C" Value="0x66" />
    <Parameter Name="EdgeLength_V100_26" Offset="0x4D" Value="0x10" />
    <Parameter Name="ResidualAmplitudeLevel_V100_53" Offset="0x4E" Value="0x00" />
    <Parameter Name="EdgeType_V100_53" Offset="0x4F" Value="0x33" />
    <Parameter Name="EdgeStyleConfiguration_V100_53" Offset="0x50" Value="0x66" />
    <Parameter Name="EdgeLength_V100_53" Offset="0x51" Value="0x10" />
    <Parameter Name="ResidualAmplitudeLevel_V100_106" Offset="0x52" Value="0x00" />
    <Parameter Name="EdgeType_V100_106" Offset="0x53" Value="0x33" />
    <Parameter Name="EdgeStyleConfiguration_V100_106" Offset="0x54" Value="0x66" />
    <Parameter Name="EdgeLength_V100_106" Offset="0x55" Value="0x10" />
    <Parameter Name="ResidualAmplitudeLevel_V100_212" Offset="0x56" Value="0x00" />
    <Parameter Name="EdgeType_V100_212" Offset="0x57" Value="0x33" />
    <Parameter Name="EdgeStyleConfiguration_V100_212" Offset="0x58" Value="0x22" />
    <Parameter Name="EdgeLength_V100_212" Offset="0x59" Value="0x10" />
    <Parameter Name="ResidualAmplitudeLevel_V10_26" Offset="0x5A" Value="0xC0" />
    <Parameter Name="EdgeType_V10_26" Offset="0x5B" Value="0x22" />
    <Parameter Name="EdgeStyleConfiguration_V10_26" Offset="0x5C" Value="0x66" />
    <Parameter Name="EdgeLength_V10_26" Offset="0x5D" Value="0x10" />
    <Parameter Name="ResidualAmplitudeLevel_V10_53" Offset="0x5E" Value="0xC0" />
    <Parameter Name="EdgeType_V10_53" Offset="0x5F" Value="0x22" />
  </Region>
</EEPROM>
```

```

<Parameter Name="EdgeStyleConfiguration_V10_53" Offset="0x60" Value="0x23" />
<Parameter Name="EdgeLength_V10_53" Offset="0x61" Value="0x10" />
<Parameter Name="ResidualAmplitudeLevel_V10_106" Offset="0x62" Value="0xC0" />
<Parameter Name="EdgeType_V10_106" Offset="0x63" Value="0x22" />
<Parameter Name="EdgeStyleConfiguration_V10_106" Offset="0x64" Value="0x23" />
<Parameter Name="EdgeLength_V10_106" Offset="0x65" Value="0x10" />
<Parameter Name="ResidualAmplitudeLevel_V10_212" Offset="0x66" Value="0xC0" />
<Parameter Name="EdgeType_V10_212" Offset="0x67" Value="0x22" />
<Parameter Name="EdgeStyleConfiguration_V10_212" Offset="0x68" Value="0x23" />
<Parameter Name="EdgeLength_V10_212" Offset="0x69" Value="0x10" />
<Parameter Name="ResidualAmplitudeLevel_180003m3_tari18p88" Offset="0x6A" Value="0xC0" />
<Parameter Name="EdgeType_180003m3_tari18p88" Offset="0x6B" Value="0x22" />
<Parameter Name="EdgeStyleConfiguration_180003m3_tari18p88" Offset="0x6C" Value="0x66" />
<Parameter Name="EdgeLength_180003m3_tari18p88" Offset="0x6D" Value="0x10" />
<Parameter Name="ResidualAmplitudeLevel_180003m3_tari9p44" Offset="0x6E" Value="0xC0" />
<Parameter Name="EdgeType_180003m3_tari9p44" Offset="0x6F" Value="0x22" />
<Parameter Name="EdgeStyleConfiguration_180003m3_tari9p44" Offset="0x70" Value="0x66" />
<Parameter Name="EdgeLength_180003m3_tari9p44" Offset="0x71" Value="0x10" />
<Parameter Name="ResidualAmplitudeLevel_B_prime106" Offset="0x72" Value="0xCF" />
<Parameter Name="EdgeType_B_prime106" Offset="0x73" Value="0x22" />
<Parameter Name="EdgeStyleConfiguration_B_prime106" Offset="0x74" Value="0x67" />
<Parameter Name="EdgeLength_B_prime106" Offset="0x75" Value="0x10" />
</Region>

<Region RegionName="DPC_SETTINGS" RegionAccess="RW" RegionType="DATA">
<Parameter Name="DPC_CONFIG" Offset="0x76" Value="0x77" />
<Parameter Name="DPC_TARGET_CURRENT" Offset="0x77" Value="0x0132" />
<Parameter Name="DPC_HYSTERESIS_LOADING" Offset="0x79" Value="0x14" />
<Parameter Name="DPC_HYSTERESIS_UNLOADING" Offset="0x7C" Value="0x0A" />
<Parameter Name="DPC_TXLDOVDDPAlow" Offset="0x7D" Value="0x07" />
<Parameter Name="DPC_TXGSM" Offset="0x7E" Value="0x03" />
<Parameter Name="DPC_RDON_Control" Offset="0x7F" Value="0x01" />
<Parameter Name="DPC_InitialRDON_RfOn" Offset="0x80" Value="0x03" />
<Parameter Name="DPC_GAURD_TIME" Offset="0x87" Value="0x64" />
<Parameter Name="DPC_ENABLE_DURING_FDT" Offset="0x88" Value="0x01" />
<Parameter Name="DPC_GAURD_TIME_AFTER_RX" Offset="0x89" Value="0x01" />
<Parameter Name="Entry_00" Offset="0x8B" Value="0x0000137F" />
<Parameter Name="Entry_01" Offset="0x8F" Value="0x0000137F" />
<Parameter Name="Entry_02" Offset="0x93" Value="0x0000137F" />
<Parameter Name="Entry_03" Offset="0x97" Value="0x0000137F" />
<Parameter Name="Entry_04" Offset="0x9B" Value="0x0000137F" />
<Parameter Name="Entry_05" Offset="0x9F" Value="0x0000137F" />
<Parameter Name="Entry_06" Offset="0xA3" Value="0x0000007F" />
<Parameter Name="Entry_07" Offset="0xA7" Value="0x0000007F" />
<Parameter Name="Entry_08" Offset="0xAB" Value="0x0000007F" />
<Parameter Name="Entry_09" Offset="0xAF" Value="0x0000007F" />
<Parameter Name="Entry_10" Offset="0xB3" Value="0x0000007F" />
<Parameter Name="Entry_11" Offset="0xB7" Value="0x0000007F" />
<Parameter Name="Entry_12" Offset="0xBB" Value="0x0000007F" />
<Parameter Name="Entry_13" Offset="0xBF" Value="0x0000007F" />
<Parameter Name="Entry_14" Offset="0xC3" Value="0x0000007F" />
<Parameter Name="Entry_15" Offset="0xC7" Value="0x0000007F" />
<Parameter Name="Entry_16" Offset="0xCB" Value="0x0000007F" />
<Parameter Name="Entry_17" Offset="0xCF" Value="0x0000007F" />
<Parameter Name="Entry_18" Offset="0xD3" Value="0x0000007F" />
<Parameter Name="Entry_19" Offset="0xD7" Value="0x0000007F" />
<Parameter Name="Entry_20" Offset="0xDB" Value="0x0000007F" />
<Parameter Name="Entry_21" Offset="0xDF" Value="0x0000007F" />
<Parameter Name="Entry_22" Offset="0xE3" Value="0x0000007F" />
<Parameter Name="Entry_23" Offset="0xE7" Value="0x0000007B" />
<Parameter Name="Entry_24" Offset="0xEB" Value="0x0000007B" />
<Parameter Name="Entry_25" Offset="0xEF" Value="0x00000079" />
<Parameter Name="Entry_26" Offset="0xF3" Value="0x00000077" />
<Parameter Name="Entry_27" Offset="0xF7" Value="0x00000075" />
<Parameter Name="Entry_28" Offset="0xFB" Value="0x00000073" />
<Parameter Name="Entry_29" Offset="0xFF" Value="0x00000071" />
<Parameter Name="Entry_30" Offset="0x103" Value="0x0000006F" />
<Parameter Name="Entry_31" Offset="0x107" Value="0x0000006E" />
<Parameter Name="Entry_32" Offset="0x10B" Value="0x0000006C" />
<Parameter Name="Entry_33" Offset="0x10F" Value="0x0000006A" />
<Parameter Name="Entry_34" Offset="0x113" Value="0x00000068" />
<Parameter Name="Entry_35" Offset="0x117" Value="0x00000066" />
<Parameter Name="Entry_36" Offset="0x11B" Value="0x00000057" />
<Parameter Name="Entry_37" Offset="0x11F" Value="0x0000004B" />
<Parameter Name="Entry_38" Offset="0x123" Value="0x0000003F" />
<Parameter Name="Entry_39" Offset="0x127" Value="0x0000002D" />
<Parameter Name="Entry_40" Offset="0x12B" Value="0x00000000" />
<Parameter Name="Entry_41" Offset="0x12F" Value="0x00000000" />
<Parameter Name="Entry_42" Offset="0x133" Value="0x00000000" />
</Region>

<Region RegionName="ARC_SETTINGS" RegionAccess="RW" RegionType="DATA">
<Parameter Name="ArcConfig" Offset="0x137" Value="0x00E4" />
<Parameter Name="ArcVddpa" Offset="0x139" Value="0x2A24130E07" />
<Parameter Name="RmArcA_106" Offset="0x13E" Value="0x81348015802A8220C250" />
<Parameter Name="RmArcA_212" Offset="0x148" Value="0x001A00200030007F407E" />
<Parameter Name="RmArcA_424" Offset="0x152" Value="0x001A00200040007F407E" />
<Parameter Name="RmArcA_848" Offset="0x15C" Value="0x001A00200040007F407E" />
<Parameter Name="RmArcB_106" Offset="0x166" Value="0x001A0020003000404050" />
<Parameter Name="RmArcB_212" Offset="0x170" Value="0x001A002000400050407E" />
<Parameter Name="RmArcB_424" Offset="0x17A" Value="0x001A002000400050407E" />
<Parameter Name="RmArcB_848" Offset="0x184" Value="0x001A002000400050407E" />
<Parameter Name="RmArcF_212" Offset="0x18E" Value="0x001A00200040007F407E" />
<Parameter Name="RmArcF_424" Offset="0x198" Value="0x001A00200040007F407E" />
<Parameter Name="RmArcV_6p6" Offset="0x1A2" Value="0x000A000A000A00A40A" />
<Parameter Name="RmArcV_26" Offset="0x1AC" Value="0x000A000A002F002F402F" />
<Parameter Name="RmArcV_53" Offset="0x1B6" Value="0x010A010A011F011F411F" />
<Parameter Name="RmArcV_106" Offset="0x1C0" Value="0x000A000A002F002F402E" />
<Parameter Name="RmArcV_212" Offset="0x1CA" Value="0x000A000A002F002F402E" />
<Parameter Name="RmArc180003m3_SC424_4Man" Offset="0x1D4" Value="0x0114011F011F001F401F" />
<Parameter Name="RmArc180003m3_SC424_2Man" Offset="0x1DE" Value="0x0014001F003F004F404F" />

```

```

<Parameter Name="RmArc180003m3_SC848_4Man" Offset="0x1E8" Value="0x0114011F011F001F401F" />
<Parameter Name="RmArc180003m3_SC848_2Man" Offset="0x1F2" Value="0x0014001F003F004F404F" />
<Parameter Name="RmArc_AI_106" Offset="0x1FC" Value="0x000A000A000A000A400A" />
<Parameter Name="RmArc_AI_212" Offset="0x206" Value="0x000A000A000A000A400A" />
<Parameter Name="RmArc_AI_424" Offset="0x210" Value="0x000A000A000A000A400A" />
</Region>

<Region RegionName="AUTOCOLL_CFG" RegionAccess="RW" RegionType="DATA">
<Parameter Name="RfDebounceTimeout" Offset="0x2B2" Value="0x10" />
<Parameter Name="SensRes" Offset="0x2B3" Value="0x0042" />
<Parameter Name="NfcID1" Offset="0x2B5" Value="0xCCBBAA" />
<Parameter Name="SelRes" Offset="0x2B8" Value="0x60" />
<Parameter Name="PollRes" Offset="0x2B9" Value="0xFFD08584424B0B100814119814011401FE01" />
<Parameter Name="RandomUIDEnable" Offset="0x2CB" Value="0x00" />
</Region>

<Region RegionName="MFC_CFG" RegionAccess="RW" RegionType="DATA">
<Parameter Name="MfcAuthTimeout" Offset="0x2CC" Value="0x0500" />
</Region>

<Region RegionName="APC_RSSI" RegionAccess="RW" RegionType="DATA">
<Parameter Name="RssiTimer" Offset="0x2DA" Value="0x0423" />
<Parameter Name="RssiTimerFirstPeriod" Offset="0x2DC" Value="0x013D" />
<Parameter Name="RssiCtrl_00_AB" Offset="0x2DE" Value="0x09" />
<Parameter Name="RssiNbEntriesAB" Offset="0x2DF" Value="0x16" />
<Parameter Name="RssiThresholdAB_01" Offset="0x2E0" Value="0x2816" />
<Parameter Name="ArbPhaseAB_01" Offset="0x2E2" Value="0x0000" />
<Parameter Name="RssiThresholdAB_02" Offset="0x2E4" Value="0x3215" />
<Parameter Name="ArbPhaseAB_02" Offset="0x2E6" Value="0x0000" />
<Parameter Name="RssiThresholdAB_03" Offset="0x2E8" Value="0x3B6E" />
<Parameter Name="ArbPhaseAB_03" Offset="0x2EA" Value="0x0000" />
<Parameter Name="RssiThresholdAB_04" Offset="0x2EC" Value="0x456A" />
<Parameter Name="ArbPhaseAB_04" Offset="0x2EE" Value="0x0000" />
<Parameter Name="RssiThresholdAB_05" Offset="0x2F0" Value="0x4FDC" />
<Parameter Name="ArbPhaseAB_05" Offset="0x2F2" Value="0x0000" />
<Parameter Name="RssiThresholdAB_06" Offset="0x2F4" Value="0x5983" />
<Parameter Name="ArbPhaseAB_06" Offset="0x2F6" Value="0x0000" />
<Parameter Name="RssiThresholdAB_07" Offset="0x2F8" Value="0x96F9" />
<Parameter Name="ArbPhaseAB_07" Offset="0x2FA" Value="0x0000" />
<Parameter Name="RssiThresholdAB_08" Offset="0x2FC" Value="0x96F9" />
<Parameter Name="ArbPhaseAB_08" Offset="0x2FE" Value="0x0000" />
<Parameter Name="RssiThresholdAB_09" Offset="0x300" Value="0x96F9" />
<Parameter Name="ArbPhaseAB_09" Offset="0x302" Value="0x0000" />
<Parameter Name="RssiThresholdAB_0A" Offset="0x304" Value="0x96F9" />
<Parameter Name="ArbPhaseAB_0A" Offset="0x306" Value="0x0000" />
<Parameter Name="RssiThresholdAB_0B" Offset="0x308" Value="0x96F9" />
<Parameter Name="ArbPhaseAB_0B" Offset="0x30A" Value="0x0000" />
<Parameter Name="RssiThresholdAB_0C" Offset="0x30C" Value="0x96F9" />
<Parameter Name="ArbPhaseAB_0C" Offset="0x30E" Value="0x0000" />
<Parameter Name="RssiThresholdAB_0D" Offset="0x310" Value="0x96F9" />
<Parameter Name="ArbPhaseAB_0D" Offset="0x312" Value="0x0000" />
<Parameter Name="RssiThresholdAB_0E" Offset="0x314" Value="0x96F9" />
<Parameter Name="ArbPhaseAB_0E" Offset="0x316" Value="0x0000" />
<Parameter Name="RssiThresholdAB_0F" Offset="0x318" Value="0x96F9" />
<Parameter Name="ArbPhaseAB_0F" Offset="0x31A" Value="0x0000" />
<Parameter Name="RssiThresholdAB_10" Offset="0x31C" Value="0x96F9" />
<Parameter Name="ArbPhaseAB_10" Offset="0x31E" Value="0x0000" />
<Parameter Name="RssiThresholdAB_11" Offset="0x320" Value="0x96F9" />
<Parameter Name="ArbPhaseAB_11" Offset="0x322" Value="0x0000" />
<Parameter Name="RssiThresholdAB_12" Offset="0x324" Value="0x96F9" />
<Parameter Name="ArbPhaseAB_12" Offset="0x326" Value="0x0000" />
<Parameter Name="RssiThresholdAB_13" Offset="0x328" Value="0x96F9" />
<Parameter Name="ArbPhaseAB_13" Offset="0x32A" Value="0x0000" />
<Parameter Name="RssiThresholdAB_14" Offset="0x32C" Value="0x96F9" />
<Parameter Name="ArbPhaseAB_14" Offset="0x32E" Value="0x0000" />
<Parameter Name="RssiThresholdAB_15" Offset="0x330" Value="0x96F9" />
<Parameter Name="ArbPhaseAB_15" Offset="0x332" Value="0x0000" />
<Parameter Name="RssiThresholdAB_16" Offset="0x334" Value="0x96F9" />
<Parameter Name="ArbPhaseAB_16" Offset="0x336" Value="0x0000" />
<Parameter Name="RssiThresholdAB_17" Offset="0x338" Value="0x96F9" />
<Parameter Name="ArbPhaseAB_17" Offset="0x33A" Value="0x0000" />
<Parameter Name="RssiThresholdAB_18" Offset="0x33C" Value="0x96F9" />
<Parameter Name="ArbPhaseAB_18" Offset="0x33E" Value="0x0000" />
<Parameter Name="RssiCtrl_00_F" Offset="0x340" Value="0x09" />
<Parameter Name="RssiNbEntriesF" Offset="0x341" Value="0x16" />
<Parameter Name="RssiThresholdF_01" Offset="0x342" Value="0x2816" />
<Parameter Name="ArbPhaseF_01" Offset="0x344" Value="0x0000" />
<Parameter Name="RssiThresholdF_02" Offset="0x346" Value="0x3215" />
<Parameter Name="ArbPhaseF_02" Offset="0x348" Value="0x0000" />
<Parameter Name="RssiThresholdF_03" Offset="0x34A" Value="0x3B6E" />
<Parameter Name="ArbPhaseF_03" Offset="0x34C" Value="0x0000" />
<Parameter Name="RssiThresholdF_04" Offset="0x34E" Value="0x456A" />
<Parameter Name="ArbPhaseF_04" Offset="0x350" Value="0x0000" />
<Parameter Name="RssiThresholdF_05" Offset="0x352" Value="0x4FDC" />
<Parameter Name="ArbPhaseF_05" Offset="0x354" Value="0x0000" />
<Parameter Name="RssiThresholdF_06" Offset="0x356" Value="0x5983" />
<Parameter Name="ArbPhaseF_06" Offset="0x358" Value="0x0000" />
<Parameter Name="RssiThresholdF_07" Offset="0x35A" Value="0x96F9" />
<Parameter Name="ArbPhaseF_07" Offset="0x35C" Value="0x0000" />
<Parameter Name="RssiThresholdF_08" Offset="0x35E" Value="0x96F9" />
<Parameter Name="ArbPhaseF_08" Offset="0x360" Value="0x0000" />
<Parameter Name="RssiThresholdF_09" Offset="0x362" Value="0x96F9" />
<Parameter Name="ArbPhaseF_09" Offset="0x364" Value="0x0000" />
<Parameter Name="RssiThresholdF_0A" Offset="0x366" Value="0x96F9" />
<Parameter Name="ArbPhaseF_0A" Offset="0x368" Value="0x0000" />
<Parameter Name="RssiThresholdF_0B" Offset="0x36A" Value="0x96F9" />
<Parameter Name="ArbPhaseF_0B" Offset="0x36C" Value="0x0000" />
<Parameter Name="RssiThresholdF_0C" Offset="0x36E" Value="0x96F9" />
<Parameter Name="ArbPhaseF_0C" Offset="0x370" Value="0x0000" />
<Parameter Name="RssiThresholdF_0D" Offset="0x372" Value="0x96F9" />
<Parameter Name="ArbPhaseF_0D" Offset="0x374" Value="0x0000" />

```

```

<Parameter Name="RssiThresholdF_0E" Offset="0x376" Value="0x96F9" />
<Parameter Name="ArbPhaseF_0E" Offset="0x378" Value="0x0000" />
<Parameter Name="RssiThresholdF_0F" Offset="0x37A" Value="0x96F9" />
<Parameter Name="ArbPhaseF_0F" Offset="0x37C" Value="0x0000" />
<Parameter Name="RssiThresholdF_10" Offset="0x37E" Value="0x96F9" />
<Parameter Name="ArbPhaseF_10" Offset="0x380" Value="0x0000" />
<Parameter Name="RssiThresholdF_11" Offset="0x382" Value="0x96F9" />
<Parameter Name="ArbPhaseF_11" Offset="0x384" Value="0x0000" />
<Parameter Name="RssiThresholdF_12" Offset="0x386" Value="0x96F9" />
<Parameter Name="ArbPhaseF_12" Offset="0x388" Value="0x0000" />
<Parameter Name="RssiThresholdF_13" Offset="0x38A" Value="0x96F9" />
<Parameter Name="ArbPhaseF_13" Offset="0x38C" Value="0x0000" />
<Parameter Name="RssiThresholdF_14" Offset="0x38E" Value="0x96F9" />
<Parameter Name="ArbPhaseF_14" Offset="0x390" Value="0x0000" />
<Parameter Name="RssiThresholdF_15" Offset="0x392" Value="0x96F9" />
<Parameter Name="ArbPhaseF_15" Offset="0x394" Value="0x0000" />
<Parameter Name="RssiThresholdF_16" Offset="0x396" Value="0x96F9" />
<Parameter Name="ArbPhaseF_16" Offset="0x398" Value="0x0000" />
<Parameter Name="RssiThresholdF_17" Offset="0x39A" Value="0x96F9" />
<Parameter Name="ArbPhaseF_17" Offset="0x39C" Value="0x0000" />
<Parameter Name="RssiThresholdF_18" Offset="0x39E" Value="0x96F9" />
<Parameter Name="ArbPhaseF_18" Offset="0x3A0" Value="0x0000" />
</Region>

<Region RegionName="APC_TX" RegionAccess="RW" RegionType="DATA">
<Parameter Name="TxParamEntry_00_ID" Offset="0x3A2" Value="0x40" />
<Parameter Name="TxParamEntry_00_Tx1" Offset="0x3A3" Value="0x00" />
<Parameter Name="TxParamEntry_00_Tx2" Offset="0x3A4" Value="0x64" />
<Parameter Name="TxParamEntry_01_ID" Offset="0x3A5" Value="0x41" />
<Parameter Name="TxParamEntry_01_Tx1" Offset="0x3A6" Value="0x00" />
<Parameter Name="TxParamEntry_01_Tx2" Offset="0x3A7" Value="0x64" />
<Parameter Name="TxParamEntry_02_ID" Offset="0x3A8" Value="0x42" />
<Parameter Name="TxParamEntry_02_Tx1" Offset="0x3A9" Value="0x00" />
<Parameter Name="TxParamEntry_02_Tx2" Offset="0x3AA" Value="0x64" />
<Parameter Name="TxParamEntry_03_ID" Offset="0x3AB" Value="0x43" />
<Parameter Name="TxParamEntry_03_Tx1" Offset="0x3AC" Value="0x00" />
<Parameter Name="TxParamEntry_03_Tx2" Offset="0x3AD" Value="0x64" />
<Parameter Name="TxParamEntry_04_ID" Offset="0x3AE" Value="0x44" />
<Parameter Name="TxParamEntry_04_Tx1" Offset="0x3AF" Value="0x00" />
<Parameter Name="TxParamEntry_04_Tx2" Offset="0x3B0" Value="0x64" />
<Parameter Name="TxParamEntry_05_ID" Offset="0x3B1" Value="0x45" />
<Parameter Name="TxParamEntry_05_Tx1" Offset="0x3B2" Value="0x00" />
<Parameter Name="TxParamEntry_05_Tx2" Offset="0x3B3" Value="0x64" />
<Parameter Name="TxParamEntry_06_ID" Offset="0x3B4" Value="0x46" />
<Parameter Name="TxParamEntry_06_Tx1" Offset="0x3B5" Value="0x00" />
<Parameter Name="TxParamEntry_06_Tx2" Offset="0x3B6" Value="0x64" />
<Parameter Name="TxParamEntry_07_ID" Offset="0x3B7" Value="0x47" />
<Parameter Name="TxParamEntry_07_Tx1" Offset="0x3B8" Value="0x00" />
<Parameter Name="TxParamEntry_07_Tx2" Offset="0x3B9" Value="0x64" />
<Parameter Name="TxParamEntry_08_ID" Offset="0x3BA" Value="0x48" />
<Parameter Name="TxParamEntry_08_Tx1" Offset="0x3BB" Value="0x00" />
<Parameter Name="TxParamEntry_08_Tx2" Offset="0x3BC" Value="0x64" />
<Parameter Name="TxParamEntry_09_ID" Offset="0x3BD" Value="0x49" />
<Parameter Name="TxParamEntry_09_Tx1" Offset="0x3BE" Value="0x00" />
<Parameter Name="TxParamEntry_09_Tx2" Offset="0x3BF" Value="0x64" />
<Parameter Name="TxParamEntry_0A_ID" Offset="0x3C0" Value="0x4A" />
<Parameter Name="TxParamEntry_0A_Tx1" Offset="0x3C1" Value="0x00" />
<Parameter Name="TxParamEntry_0A_Tx2" Offset="0x3C2" Value="0x64" />
<Parameter Name="TxParamEntry_0B_ID" Offset="0x3C3" Value="0x4B" />
<Parameter Name="TxParamEntry_0B_Tx1" Offset="0x3C4" Value="0x00" />
<Parameter Name="TxParamEntry_0B_Tx2" Offset="0x3C5" Value="0x64" />
<Parameter Name="TxParamEntry_0C_ID" Offset="0x3C6" Value="0x4C" />
<Parameter Name="TxParamEntry_00C_Tx1" Offset="0x3C7" Value="0x00" />
<Parameter Name="TxParamEntry_00C_Tx2" Offset="0x3C8" Value="0x4F" />
<Parameter Name="TxParamEntry_0D_ID" Offset="0x3C9" Value="0x4D" />
<Parameter Name="TxParamEntry_0D_Tx1" Offset="0x3CA" Value="0x00" />
<Parameter Name="TxParamEntry_0D_Tx2" Offset="0x3CB" Value="0x47" />
<Parameter Name="TxParamEntry_0E_ID" Offset="0x3CC" Value="0x4E" />
<Parameter Name="TxParamEntry_0E_Tx1" Offset="0x3CD" Value="0x00" />
<Parameter Name="TxParamEntry_0E_Tx2" Offset="0x3CE" Value="0x3F" />
<Parameter Name="TxParamEntry_0F_ID" Offset="0x3CF" Value="0x4F" />
<Parameter Name="TxParamEntry_0F_Tx1" Offset="0x3D0" Value="0x00" />
<Parameter Name="TxParamEntry_0F_Tx2" Offset="0x3D1" Value="0x37" />
<Parameter Name="TxParamEntry_10_ID" Offset="0x3D2" Value="0x50" />
<Parameter Name="TxParamEntry_10_Tx1" Offset="0x3D3" Value="0x00" />
<Parameter Name="TxParamEntry_10_Tx2" Offset="0x3D4" Value="0x37" />
<Parameter Name="TxParamEntry_11_ID" Offset="0x3D5" Value="0x51" />
<Parameter Name="TxParamEntry_11_Tx1" Offset="0x3D6" Value="0x00" />
<Parameter Name="TxParamEntry_11_Tx2" Offset="0x3D7" Value="0x37" />
<Parameter Name="TxParamEntry_12_ID" Offset="0x3D8" Value="0x52" />
<Parameter Name="TxParamEntry_12_Tx1" Offset="0x3D9" Value="0x00" />
<Parameter Name="TxParamEntry_12_Tx2" Offset="0x3DA" Value="0x37" />
<Parameter Name="TxParamEntry_13_ID" Offset="0x3DB" Value="0x53" />
<Parameter Name="TxParamEntry_13_Tx1" Offset="0x3DC" Value="0x00" />
<Parameter Name="TxParamEntry_13_Tx2" Offset="0x3DD" Value="0x37" />
<Parameter Name="TxParamEntry_14_ID" Offset="0x3DE" Value="0x54" />
<Parameter Name="TxParamEntry_14_Tx1" Offset="0x3DF" Value="0x00" />
<Parameter Name="TxParamEntry_14_Tx2" Offset="0x3E0" Value="0x37" />
<Parameter Name="TxParamEntry_15_ID" Offset="0x3E1" Value="0x55" />
<Parameter Name="TxParamEntry_15_Tx1" Offset="0x3E2" Value="0x00" />
<Parameter Name="TxParamEntry_15_Tx2" Offset="0x3E3" Value="0x37" />
<Parameter Name="TxParamEntry_16_ID" Offset="0x3E4" Value="0x56" />
<Parameter Name="TxParamEntry_16_Tx1" Offset="0x3E5" Value="0x00" />
<Parameter Name="TxParamEntry_16_Tx2" Offset="0x3E6" Value="0x37" />
<Parameter Name="TxParamEntry_17_ID" Offset="0x3E7" Value="0x57" />
<Parameter Name="TxParamEntry_17_Tx1" Offset="0x3E8" Value="0x00" />
<Parameter Name="TxParamEntry_17_Tx2" Offset="0x3E9" Value="0x37" />
<Parameter Name="TxParamEntry_18_ID" Offset="0x3EA" Value="0x58" />
<Parameter Name="TxParamEntry_18_Tx1" Offset="0x3EB" Value="0x00" />
<Parameter Name="TxParamEntry_18_Tx2" Offset="0x3EC" Value="0x37" />
<Parameter Name="TxParamEntry_19_ID" Offset="0x3ED" Value="0x59" />

```



```

<Parameter Name="TxParamEntry_3B_ID" Offset="0x453" Value="0x7B" />
<Parameter Name="TxParamEntry_3B_Tx1" Offset="0x454" Value="0x00" />
<Parameter Name="TxParamEntry_3B_Tx2" Offset="0x455" Value="0x37" />
<Parameter Name="TxParamEntry_3C_ID" Offset="0x456" Value="0x7C" />
<Parameter Name="TxParamEntry_3C_Tx1" Offset="0x457" Value="0x00" />
<Parameter Name="TxParamEntry_3C_Tx2" Offset="0x458" Value="0x37" />
<Parameter Name="TxParamEntry_3D_ID" Offset="0x459" Value="0x7D" />
<Parameter Name="TxParamEntry_3D_Tx1" Offset="0x45A" Value="0x00" />
<Parameter Name="TxParamEntry_3D_Tx2" Offset="0x45B" Value="0x37" />
<Parameter Name="TxParamEntry_3E_ID" Offset="0x45C" Value="0x7E" />
<Parameter Name="TxParamEntry_3E_Tx1" Offset="0x45D" Value="0x00" />
<Parameter Name="TxParamEntry_3E_Tx2" Offset="0x45E" Value="0x37" />
<Parameter Name="TxParamEntry_3F_ID" Offset="0x45F" Value="0x7F" />
<Parameter Name="TxParamEntry_3F_Tx1" Offset="0x460" Value="0x00" />
<Parameter Name="TxParamEntry_3F_Tx2" Offset="0x461" Value="0x37" />
<Parameter Name="TxParamEntry_40_ID" Offset="0x462" Value="0x7F" />
<Parameter Name="TxParamEntry_40_Tx1" Offset="0x463" Value="0x00" />
<Parameter Name="TxParamEntry_40_Tx2" Offset="0x464" Value="0x37" />
<Parameter Name="TxParamEntry_41_ID" Offset="0x465" Value="0x7F" />
<Parameter Name="TxParamEntry_41_Tx1" Offset="0x466" Value="0x00" />
<Parameter Name="TxParamEntry_41_Tx2" Offset="0x467" Value="0x37" />
<Parameter Name="TxParamEntry_42_ID" Offset="0x468" Value="0x7F" />
<Parameter Name="TxParamEntry_42_Tx1" Offset="0x469" Value="0x00" />
<Parameter Name="TxParamEntry_42_Tx2" Offset="0x46A" Value="0x37" />
<Parameter Name="TxParamEntry_43_ID" Offset="0x46B" Value="0x7F" />
<Parameter Name="TxParamEntry_43_Tx1" Offset="0x46C" Value="0x00" />
<Parameter Name="TxParamEntry_43_Tx2" Offset="0x46D" Value="0x37" />
<Parameter Name="TxParamEntry_44_ID" Offset="0x46E" Value="0x7F" />
<Parameter Name="TxParamEntry_44_Tx1" Offset="0x46F" Value="0x00" />
<Parameter Name="TxParamEntry_44_Tx2" Offset="0x470" Value="0x37" />
<Parameter Name="TxParamEntry_45_ID" Offset="0x471" Value="0x7F" />
<Parameter Name="TxParamEntry_45_Tx1" Offset="0x472" Value="0x00" />
<Parameter Name="TxParamEntry_45_Tx2" Offset="0x473" Value="0x37" />
<Parameter Name="TxParamEntry_46_ID" Offset="0x474" Value="0x7F" />
<Parameter Name="TxParamEntry_46_Tx1" Offset="0x475" Value="0x00" />
<Parameter Name="TxParamEntry_46_Tx2" Offset="0x476" Value="0x37" />
<Parameter Name="TxParamEntry_47_ID" Offset="0x477" Value="0x7F" />
<Parameter Name="TxParamEntry_47_Tx1" Offset="0x478" Value="0x00" />
<Parameter Name="TxParamEntry_47_Tx2" Offset="0x479" Value="0x37" />
<Parameter Name="TxParamEntry_48_ID" Offset="0x47A" Value="0x7F" />
<Parameter Name="TxParamEntry_48_Tx1" Offset="0x47B" Value="0x00" />
<Parameter Name="TxParamEntry_48_Tx2" Offset="0x47C" Value="0x37" />
<Parameter Name="TxParamEntry_49_ID" Offset="0x47D" Value="0x7F" />
<Parameter Name="TxParamEntry_49_Tx1" Offset="0x47E" Value="0x00" />
<Parameter Name="TxParamEntry_49_Tx2" Offset="0x47F" Value="0x37" />
<Parameter Name="TxParamEntry_4A_ID" Offset="0x480" Value="0x7F" />
<Parameter Name="TxParamEntry_4A_Tx1" Offset="0x481" Value="0x00" />
<Parameter Name="TxParamEntry_4A_Tx2" Offset="0x482" Value="0x37" />
<Parameter Name="TxParamEntry_4B_ID" Offset="0x483" Value="0x7F" />
<Parameter Name="TxParamEntry_4B_Tx1" Offset="0x484" Value="0x00" />
<Parameter Name="TxParamEntry_4B_Tx2" Offset="0x485" Value="0x37" />
<Parameter Name="TxParamEntry_4C_ID" Offset="0x486" Value="0x7F" />
<Parameter Name="TxParamEntry_4C_Tx1" Offset="0x487" Value="0x00" />
<Parameter Name="TxParamEntry_4C_Tx2" Offset="0x488" Value="0x37" />
<Parameter Name="TxParamEntry_4D_ID" Offset="0x489" Value="0x7F" />
<Parameter Name="TxParamEntry_4D_Tx1" Offset="0x48A" Value="0x00" />
<Parameter Name="TxParamEntry_4D_Tx2" Offset="0x48B" Value="0x37" />
<Parameter Name="TxParamEntry_4E_ID" Offset="0x48C" Value="0x7F" />
<Parameter Name="TxParamEntry_4E_Tx1" Offset="0x48D" Value="0x00" />
<Parameter Name="TxParamEntry_4E_Tx2" Offset="0x48E" Value="0x37" />
<Parameter Name="dummy" Offset="0x48F" Value="0x000000" />
</Region>

<Region RegionName="LPCD_SETTINGS" RegionAccess="RW" RegionType="DATA">
<Parameter Name="avg_samples" Offset="0x492" Value="0x06" />
<Parameter Name="lpcd_rssi_target" Offset="0x494" Value="0x02A3" />
<Parameter Name="lpcd_rssi_hyst" Offset="0x496" Value="0x01F" />
<Parameter Name="Config" Offset="0x497" Value="0x003B" />
<Parameter Name="lpcd_threshold_coarse" Offset="0x49A" Value="0x00500050" />
<Parameter Name="lpcd_threshold_fine" Offset="0x49E" Value="0x7FFF7FFF" />
</Region>

<Region RegionName="ULPCD_CONFIG" RegionAccess="RW" RegionType="DATA">
<Parameter Name="Vddpa_Ctrl" Offset="0x4BF" Value="0x0206" />
<Parameter Name="Timing_Ctrl" Offset="0x4C2" Value="0x3D" />
<Parameter Name="Voltage_Ctrl" Offset="0x4C6" Value="0x6A" />
</Region>

<Region RegionName="ULPCD_SETTINGS" RegionAccess="RW" RegionType="DATA">
<Parameter Name="rssi_nsp" Offset="0x4C9" Value="0x10" />
<Parameter Name="rssi_no_samples" Offset="0x4CA" Value="0x00" />
<Parameter Name="thresh_lv1" Offset="0x4CB" Value="0x0C" />
<Parameter Name="polarity" Offset="0x4CC" Value="0x01" />
</Region>

<Region RegionName="TXIRQ_GUARD" RegionAccess="RW" RegionType="DATA">
<Parameter Name="TXIRQ_GuardTime" Offset="0x559" Value="0x000FFFFF" />
</Region>

<Region RegionName="FDT_DEFAULT" RegionAccess="RW" RegionType="DATA">
<Parameter Name="FDT_DefaultVal" Offset="0x55D" Value="0x000472AC" />
</Region>

<Region RegionName="RXIRQ_GUARD" RegionAccess="RW" RegionType="DATA">
<Parameter Name="RXIRQ_GuardTime" Offset="0x561" Value="0x000F4240" />
</Region>

<Region RegionName="TX_SHAPING_PROPRIETARY CORR" RegionAccess="RW" RegionType="DATA">
<Parameter Name="Correction_Entry0" Offset="0xBAD" Value="0x0000" />
<Parameter Name="Correction_Entry1" Offset="0xBAF" Value="0x0000" />
<Parameter Name="Correction_Entry2" Offset="0xBB1" Value="0x0000" />

```

```

<Parameter Name="Correction_Entry3" Offset="0xBB3" Value="0x0000" />
<Parameter Name="Correction_Entry4" Offset="0xBB5" Value="0x0000" />
<Parameter Name="Correction_Entry5" Offset="0xBB7" Value="0x0000" />
<Parameter Name="Correction_Entry6" Offset="0xBB9" Value="0x0000" />
<Parameter Name="Correction_Entry7" Offset="0xBBB" Value="0x0000" />
<Parameter Name="Correction_Entry8" Offset="0xBBD" Value="0x0000" />
<Parameter Name="Correction_Entry9" Offset="0xBBF" Value="0x0000" />
<Parameter Name="Correction_Entry10" Offset="0xBC1" Value="0x0000" />
<Parameter Name="Correction_Entry11" Offset="0xBC3" Value="0x0000" />
<Parameter Name="Correction_Entry12" Offset="0xBC5" Value="0x0000" />
<Parameter Name="Correction_Entry13" Offset="0xBC7" Value="0x0000" />
<Parameter Name="Correction_Entry14" Offset="0xBC9" Value="0x0000" />
<Parameter Name="Correction_Entry15" Offset="0xBCB" Value="0x0000" />
<Parameter Name="Correction_Entry16" Offset="0xBCD" Value="0x0000" />
<Parameter Name="Correction_Entry17" Offset="0xBCE" Value="0x0000" />
<Parameter Name="Correction_Entry18" Offset="0xBD1" Value="0x0000" />
<Parameter Name="Correction_Entry19" Offset="0xBD3" Value="0x0000" />
<Parameter Name="Correction_Entry20" Offset="0xBD5" Value="0x0000" />
<Parameter Name="Correction_Entry21" Offset="0xBD7" Value="0x0000" />
<Parameter Name="Correction_Entry22" Offset="0xBD9" Value="0x0000" />
<Parameter Name="Correction_Entry23" Offset="0xBDB" Value="0x0000" />
<Parameter Name="Correction_Entry24" Offset="0xBDD" Value="0x0000" />
<Parameter Name="Correction_Entry25" Offset="0xBDF" Value="0x0000" />
<Parameter Name="Correction_Entry26" Offset="0xBE1" Value="0x0000" />
<Parameter Name="Correction_Entry27" Offset="0xBE3" Value="0x0000" />
<Parameter Name="Correction_Entry28" Offset="0xBE5" Value="0x0000" />
<Parameter Name="Correction_Entry29" Offset="0xBE7" Value="0x0000" />
<Parameter Name="Correction_Entry30" Offset="0xBE9" Value="0x0000" />
<Parameter Name="Correction_Entry31" Offset="0xBEB" Value="0x0000" />
<Parameter Name="Correction_Entry32" Offset="0xBED" Value="0x0000" />
<Parameter Name="Correction_Entry33" Offset="0xBEF" Value="0x0000" />
<Parameter Name="Correction_Entry34" Offset="0xBF1" Value="0x0000" />
<Parameter Name="Correction_Entry35" Offset="0xBF3" Value="0x0000" />
<Parameter Name="Correction_Entry36" Offset="0xBF5" Value="0x0000" />
<Parameter Name="Correction_Entry37" Offset="0xBF7" Value="0x0000" />
<Parameter Name="Correction_Entry38" Offset="0xBF9" Value="0x0000" />
<Parameter Name="Correction_Entry39" Offset="0xBF5" Value="0x0000" />
<Parameter Name="Correction_Entry40" Offset="0xBF7" Value="0x0000" />
<Parameter Name="Correction_Entry41" Offset="0xBF9" Value="0x0000" />
<Parameter Name="Correction_Entry42" Offset="0xC01" Value="0x0000" />
</Region>

<Region RegionName="TX_SHAPING_PROPRIETARY_1" RegionAccess="RW" RegionType="DATA">
<Parameter Name="RTRANS0" Offset="0xC03" Value="0xEAE6DCCD" />
<Parameter Name="RTRANS1" Offset="0xC07" Value="0xFAF6F2EE" />
<Parameter Name="RTRANS2" Offset="0xC0B" Value="0xFFFFFFFF" />
<Parameter Name="RTRANS3" Offset="0xC0F" Value="0xFFFFFFFF" />
<Parameter Name="FTRANS0" Offset="0xC13" Value="0xCACACACA" />
<Parameter Name="FTRANS1" Offset="0xC17" Value="0xCACACAD8" />
<Parameter Name="FTRANS2" Offset="0xC1B" Value="0xCACACACA" />
<Parameter Name="FTRANS3" Offset="0xC1F" Value="0xCACACACA" />
</Region>

<Region RegionName="TX_SHAPING_PROPRIETARY_2" RegionAccess="RW" RegionType="DATA">
<Parameter Name="RTRANS0" Offset="0xC23" Value="0xF0EAE3DA" />
<Parameter Name="RTRANS1" Offset="0xC27" Value="0xFAF9F6F4" />
<Parameter Name="RTRANS2" Offset="0xC2B" Value="0xFEFDFFDC" />
<Parameter Name="RTRANS3" Offset="0xC2F" Value="0xFFFFFFFF" />
<Parameter Name="FTRANS0" Offset="0xC33" Value="0xFFFFFFFF" />
<Parameter Name="FTRANS1" Offset="0xC37" Value="0xFCFDFDFE" />
<Parameter Name="FTRANS2" Offset="0xC3B" Value="0xF4F6F9FA" />
<Parameter Name="FTRANS3" Offset="0xC3F" Value="0xDAE3EAF0" />
</Region>

<Region RegionName="TX_SHAPING_PROPRIETARY_3" RegionAccess="RW" RegionType="DATA">
<Parameter Name="RTRANS0" Offset="0xC43" Value="0x00000000" />
<Parameter Name="RTRANS1" Offset="0xC47" Value="0x00000000" />
<Parameter Name="RTRANS2" Offset="0xC4B" Value="0x00000000" />
<Parameter Name="RTRANS3" Offset="0xC4F" Value="0x00000000" />
<Parameter Name="FTRANS0" Offset="0xC53" Value="0x00000000" />
<Parameter Name="FTRANS1" Offset="0xC57" Value="0x00000000" />
<Parameter Name="FTRANS2" Offset="0xC5B" Value="0x00000000" />
<Parameter Name="FTRANS3" Offset="0xC5F" Value="0x00000000" />
</Region>

<Region RegionName="TX_SHAPING_PROPRIETARY_4" RegionAccess="RW" RegionType="DATA">
<Parameter Name="RTRANS0" Offset="0xC63" Value="0x00000000" />
<Parameter Name="RTRANS1" Offset="0xC67" Value="0x00000000" />
<Parameter Name="RTRANS2" Offset="0xC6B" Value="0x00000000" />
<Parameter Name="RTRANS3" Offset="0xC6F" Value="0x00000000" />
<Parameter Name="FTRANS0" Offset="0xC73" Value="0x00000000" />
<Parameter Name="FTRANS1" Offset="0xC77" Value="0x00000000" />
<Parameter Name="FTRANS2" Offset="0xC7B" Value="0x00000000" />
<Parameter Name="FTRANS3" Offset="0xC7F" Value="0x00000000" />
</Region>

<Region RegionName="TX_DRIVER_NOV" RegionAccess="RW" RegionType="DATA">
<Parameter Name="CfNovCal1" Offset="0xC83" Value="0x42" />
<Parameter Name="VddpaCalVal1" Offset="0xC84" Value="0x03" />
<Parameter Name="VddpaCalVal2" Offset="0xC85" Value="0x15" />
<Parameter Name="CfThreshold" Offset="0xC86" Value="0x08" />
<Parameter Name="UserOffsets1" Offset="0xC87" Value="0x8A0A0C00" />
<Parameter Name="UserOffsets2" Offset="0xC8B" Value="0x09080D03" />
</Region>

<Region RegionName="USER_PMU_INT_1" RegionAccess="RW" RegionType="DATA">
<Parameter Name="EnableFastVDDPDischarge" Offset="0xC8F" Value="0x00" />
</Region>

<Region RegionName="ARC_SETTINGS_1" RegionAccess="RW" RegionType="DATA">
<Parameter Name="RmArca_106_FDT" Offset="0xC9D" Value="0x812A805080508050C050" />

```



```

</Protocol>
<Protocol ProtocolName="RX GTM All" ProtocolIndex="0x9C" ProtocolOffset="0x1226">
  <Register RegisterName="CLIF_ANA_RX_CTRL" RegisterLogicalAddress="0x43" RegisterValue="0x0700E437"></Register>
  <Register RegisterName="CLIF_DCOC_CONFIG" RegisterLogicalAddress="0x33" RegisterValue="0x00100032"></Register>
  <Register RegisterName="CLIF_RXM_CTRL" RegisterLogicalAddress="0x35" RegisterValue="0x0004C935"></Register>
  <Register RegisterName="CLIF_GCM_CONFIG2" RegisterLogicalAddress="0x38" RegisterValue="0x00A24820"></Register>
  <Register RegisterName="CLIF_GCM_CONFIG1" RegisterLogicalAddress="0x39" RegisterValue="0x4000003F"></Register>
  <Register RegisterName="CLIF_GCM_CONFIG0" RegisterLogicalAddress="0x3A" RegisterValue="0x00A93979"></Register>
  <Register RegisterName="CLIF_ANA_AGC_DCO_CTRL" RegisterLogicalAddress="0x36" RegisterValue="0x00000000"></Register>
  <Register RegisterName="CLIF_SIGPRO_RM_CONFIG" RegisterLogicalAddress="0x1F" RegisterValue="0x00000000"></Register>
  <Register RegisterName="CLIF_SIGPRO_RM_ENABLES" RegisterLogicalAddress="0x21" RegisterValue="0x00000000"></Register>
  <Register RegisterName="CLIF_SIGPRO_CONFIG" RegisterLogicalAddress="0x1D" RegisterValue="0x00600081"></Register>
  <Register RegisterName="CLIF_SIGPRO_NOISE_CONFIG1" RegisterLogicalAddress="0x23" RegisterValue="0x00000000"></Register>
  <Register RegisterName="CLIF_SIGPRO_NOISE_CONFIG2" RegisterLogicalAddress="0x24" RegisterValue="0x00000000"></Register>
  <Register RegisterName="CLIF_RX_ERROR_CONFIG" RegisterLogicalAddress="0x27" RegisterValue="0x000037FF"></Register>
  <Register RegisterName="CLIF_RX_EMD_0_CONFIG" RegisterLogicalAddress="0x48" RegisterValue="0x00280200"></Register>
  <Register RegisterName="CLIF_SIGPRO_IIR_CONFIG1" RegisterLogicalAddress="0x29" RegisterValue="0x00000000"></Register>
  <Register RegisterName="CLIF_SIGPRO_IIR_CONFIG0" RegisterLogicalAddress="0x2A" RegisterValue="0x00000000"></Register>
  <Register RegisterName="CLIF_DGRM_DAC_FILTER" RegisterLogicalAddress="0x2B" RegisterValue="0x00000000"></Register>
  <Register RegisterName="CLIF_DGRM_CONFIG" RegisterLogicalAddress="0x2C" RegisterValue="0x00000000"></Register>
  <Register RegisterName="CLIF_DGRM_BBA" RegisterLogicalAddress="0x2D" RegisterValue="0x00000000"></Register>
  <Register RegisterName="CLIF_DGRM_DCO" RegisterLogicalAddress="0x2E" RegisterValue="0x00000000"></Register>
  <Register RegisterName="CLIF_DGRM_HF_ATT" RegisterLogicalAddress="0x2F" RegisterValue="0x00000000"></Register>
  <Register RegisterName="CLIF_DGRM_RSSI" RegisterLogicalAddress="0x30" RegisterValue="0x00000000"></Register>
  <Register RegisterName="CLIF_SIGPRO_RM_TECH" RegisterLogicalAddress="0x22" RegisterValue="0x00000003"></Register>
  <Register RegisterName="CLIF_SIGPRO_CM_CONFIG" RegisterLogicalAddress="0x37" RegisterValue="0xBF9600A0"></Register>
</Protocol>
<Protocol ProtocolName="RX B Prime All" ProtocolIndex="0x9D" ProtocolOffset="0x129E">
  <Register RegisterName="CLIF_ANA_RX_CTRL" RegisterLogicalAddress="0x43" RegisterValue="0x0000E407"></Register>
  <Register RegisterName="CLIF_DCOC_CONFIG" RegisterLogicalAddress="0x33" RegisterValue="0x000000F4"></Register>
  <Register RegisterName="CLIF_RXM_CTRL" RegisterLogicalAddress="0x35" RegisterValue="0x0044893E"></Register>
  <Register RegisterName="CLIF_GCM_CONFIG2" RegisterLogicalAddress="0x38" RegisterValue="0x00024820"></Register>
  <Register RegisterName="CLIF_GCM_CONFIG1" RegisterLogicalAddress="0x39" RegisterValue="0x000000FC0"></Register>
  <Register RegisterName="CLIF_GCM_CONFIG0" RegisterLogicalAddress="0x3A" RegisterValue="0x00D03939"></Register>
  <Register RegisterName="CLIF_ANA_AGC_DCO_CTRL" RegisterLogicalAddress="0x36" RegisterValue="0x01000008"></Register>
  <Register RegisterName="CLIF_SIGPRO_RM_CONFIG" RegisterLogicalAddress="0x1F" RegisterValue="0x02380248"></Register>
  <Register RegisterName="CLIF_SIGPRO_RM_ENABLES" RegisterLogicalAddress="0x21" RegisterValue="0x00000055"></Register>
  <Register RegisterName="CLIF_SIGPRO_CONFIG" RegisterLogicalAddress="0x1D" RegisterValue="0x400000BE"></Register>
  <Register RegisterName="CLIF_SIGPRO_NOISE_CONFIG1" RegisterLogicalAddress="0x23" RegisterValue="0x0C082155"></Register>
  <Register RegisterName="CLIF_SIGPRO_NOISE_CONFIG2" RegisterLogicalAddress="0x24" RegisterValue="0x0085510"></Register>
  <Register RegisterName="CLIF_RX_ERROR_CONFIG" RegisterLogicalAddress="0x27" RegisterValue="0x000037FF"></Register>
  <Register RegisterName="CLIF_RX_EMD_0_CONFIG" RegisterLogicalAddress="0x48" RegisterValue="0x1F200000"></Register>
  <Register RegisterName="CLIF_SIGPRO_IIR_CONFIG1" RegisterLogicalAddress="0x29" RegisterValue="0x01B0618E"></Register>
  <Register RegisterName="CLIF_SIGPRO_IIR_CONFIG0" RegisterLogicalAddress="0x2A" RegisterValue="0x000A85CC"></Register>
  <Register RegisterName="CLIF_DGRM_DAC_FILTER" RegisterLogicalAddress="0x2B" RegisterValue="0x00889238"></Register>
  <Register RegisterName="CLIF_DGRM_CONFIG" RegisterLogicalAddress="0x2C" RegisterValue="0x00E63400"></Register>
  <Register RegisterName="CLIF_DGRM_BBA" RegisterLogicalAddress="0x2D" RegisterValue="0xED4C64A4"></Register>
  <Register RegisterName="CLIF_DGRM_DCO" RegisterLogicalAddress="0x2E" RegisterValue="0xC0F7C1F0"></Register>
  <Register RegisterName="CLIF_DGRM_HF_ATT" RegisterLogicalAddress="0x2F" RegisterValue="0x2A8FFFFF"></Register>
  <Register RegisterName="CLIF_DGRM_RSSI" RegisterLogicalAddress="0x30" RegisterValue="0x393F518A"></Register>
  <Register RegisterName="CLIF_SIGPRO_RM_TECH" RegisterLogicalAddress="0x22" RegisterValue="0x95086250"></Register>
  <Register RegisterName="CLIF_SIGPRO_CM_CONFIG" RegisterLogicalAddress="0x37" RegisterValue="0x1FE00001"></Register>
</Protocol>
</Region>
</EEPROM>

```

20 Abbreviations

Table 340. Abbreviations

Acronym	Description
ADC	analog-to-digital converter
AGC	automatic gain control
ARC	adaptive receiver control
AWC	adaptive waveshape control
CLIF	contactless interface
DAC	digital-to-analog converter
DC-DC	switch-mode voltage regulator which uses an inductor to store and transfer energy to the output, used for a power supply voltage conversion. PN5190B1 integrates a step-up/boost converter
DPC	dynamic power control
EMD	electromagnetic disturbance
GPIO	general-purpose input output
HPD	hard power down
LDO	low dropout regulator
LPCD	low-power card detection
MISO	SPI interface Master In Slave Out
MOSI	SPI interface Master Out Slave In
NSS	SPI interface active-low slave-select signal
OS	operating system
PCB	printed-circuit board
PCD	power card detection
PICC	proximity inductive coupling card
RF	radio frequency
RSSI	receiver signal strength indicator
SCK	SPI interface serial clock
SCL	I ² C interface serial clock
SPI	serial peripheral interface
TFT	display technology: thin-film transistor-display
TX	transmit
UID	Unique identifier of a card, used during anti-collision sequence to select one out of multiple cards.
ULPCD	ultra low-power card detection

21 References

- [1] Application note - AN12551 PN5190 Design-in document
- [2] Application note - AN12549 PN5190 Antenna design guide
- [3] Product data sheet addendum - AD PN5190 Instruction layer

22 Revision history

Table 341. Revision history

Document ID	Release date	Data sheet status	Supersedes
PN5190B1 v. 3.0	20210421	Product data sheet	PN5190B1 v. 1.0
Modifications:	<ul style="list-style-type: none">• General update• Data sheet status changed to "Product data sheet"		
PN5190B1 v. 1.0	20210322	Objective data sheet	-
Modifications:	<ul style="list-style-type: none">• First official released version		

23 Legal information

23.1 Data sheet status

Document status ^{[1][2]}	Product status ^[3]	Definition
Objective [short] data sheet	Development	This document contains data from the objective specification for product development.
Preliminary [short] data sheet	Qualification	This document contains data from the preliminary specification.
Product [short] data sheet	Production	This document contains the product specification.

[1] Please consult the most recently issued document before initiating or completing a design.

[2] The term 'short data sheet' is explained in section "Definitions".

[3] The product status of device(s) described in this document may have changed since this document was published and may differ in case of multiple devices. The latest product status information is available on the Internet at URL <http://www.nxp.com>.

23.2 Definitions

Draft — A draft status on a document indicates that the content is still under internal review and subject to formal approval, which may result in modifications or additions. NXP Semiconductors does not give any representations or warranties as to the accuracy or completeness of information included in a draft version of a document and shall have no liability for the consequences of use of such information.

Short data sheet — A short data sheet is an extract from a full data sheet with the same product type number(s) and title. A short data sheet is intended for quick reference only and should not be relied upon to contain detailed and full information. For detailed and full information see the relevant full data sheet, which is available on request via the local NXP Semiconductors sales office. In case of any inconsistency or conflict with the short data sheet, the full data sheet shall prevail.

Product specification — The information and data provided in a Product data sheet shall define the specification of the product as agreed between NXP Semiconductors and its customer, unless NXP Semiconductors and customer have explicitly agreed otherwise in writing. In no event however, shall an agreement be valid in which the NXP Semiconductors product is deemed to offer functions and qualities beyond those described in the Product data sheet.

23.3 Disclaimers

Limited warranty and liability — Information in this document is believed to be accurate and reliable. However, NXP Semiconductors does not give any representations or warranties, expressed or implied, as to the accuracy or completeness of such information and shall have no liability for the consequences of use of such information. NXP Semiconductors takes no responsibility for the content in this document if provided by an information source outside of NXP Semiconductors. In no event shall NXP Semiconductors be liable for any indirect, incidental, punitive, special or consequential damages (including - without limitation - lost profits, lost savings, business interruption, costs related to the removal or replacement of any products or rework charges) whether or not such damages are based on tort (including negligence), warranty, breach of contract or any other legal theory. Notwithstanding any damages that customer might incur for any reason whatsoever, NXP Semiconductors' aggregate and cumulative liability towards customer for the products described herein shall be limited in accordance with the Terms and conditions of commercial sale of NXP Semiconductors.

Right to make changes — NXP Semiconductors reserves the right to make changes to information published in this document, including without limitation specifications and product descriptions, at any time and without

notice. This document supersedes and replaces all information supplied prior to the publication hereof.

Suitability for use — NXP Semiconductors products are not designed, authorized or warranted to be suitable for use in life support, life-critical or safety-critical systems or equipment, nor in applications where failure or malfunction of an NXP Semiconductors product can reasonably be expected to result in personal injury, death or severe property or environmental damage. NXP Semiconductors and its suppliers accept no liability for inclusion and/or use of NXP Semiconductors products in such equipment or applications and therefore such inclusion and/or use is at the customer's own risk.

Applications — Applications that are described herein for any of these products are for illustrative purposes only. NXP Semiconductors makes no representation or warranty that such applications will be suitable for the specified use without further testing or modification. Customers are responsible for the design and operation of their applications and products using NXP Semiconductors products, and NXP Semiconductors accepts no liability for any assistance with applications or customer product design. It is customer's sole responsibility to determine whether the NXP Semiconductors product is suitable and fit for the customer's applications and products planned, as well as for the planned application and use of customer's third party customer(s). Customers should provide appropriate design and operating safeguards to minimize the risks associated with their applications and products. NXP Semiconductors does not accept any liability related to any default, damage, costs or problem which is based on any weakness or default in the customer's applications or products, or the application or use by customer's third party customer(s). Customer is responsible for doing all necessary testing for the customer's applications and products using NXP Semiconductors products in order to avoid a default of the applications and the products or of the application or use by customer's third party customer(s). NXP does not accept any liability in this respect.

Limiting values — Stress above one or more limiting values (as defined in the Absolute Maximum Ratings System of IEC 60134) will cause permanent damage to the device. Limiting values are stress ratings only and (proper) operation of the device at these or any other conditions above those given in the Recommended operating conditions section (if present) or the Characteristics sections of this document is not warranted. Constant or repeated exposure to limiting values will permanently and irreversibly affect the quality and reliability of the device.

Terms and conditions of commercial sale — NXP Semiconductors products are sold subject to the general terms and conditions of commercial sale, as published at <http://www.nxp.com/profile/terms>, unless otherwise agreed in a valid written individual agreement. In case an individual agreement is concluded only the terms and conditions of the respective agreement shall apply. NXP Semiconductors hereby expressly objects to applying the customer's general terms and conditions with regard to the purchase of NXP Semiconductors products by customer.

No offer to sell or license — Nothing in this document may be interpreted or construed as an offer to sell products that is open for acceptance or the grant, conveyance or implication of any license under any copyrights, patents or other industrial or intellectual property rights.

Export control — This document as well as the item(s) described herein may be subject to export control regulations. Export might require a prior authorization from competent authorities.

Non-automotive qualified products — Unless this data sheet expressly states that this specific NXP Semiconductors product is automotive qualified, the product is not suitable for automotive use. It is neither qualified nor tested in accordance with automotive testing or application requirements. NXP Semiconductors accepts no liability for inclusion and/or use of non-automotive qualified products in automotive equipment or applications. In the event that customer uses the product for design-in and use in automotive applications to automotive specifications and standards, customer (a) shall use the product without NXP Semiconductors' warranty of the product for such automotive applications, use and specifications, and (b) whenever customer uses the product for automotive applications beyond NXP Semiconductors' specifications such use shall be solely at customer's own risk, and (c) customer fully indemnifies NXP Semiconductors for any liability, damages or failed product claims resulting from customer design and use of the product for automotive applications beyond NXP Semiconductors' standard warranty and NXP Semiconductors' product specifications.

Translations — A non-English (translated) version of a document is for reference only. The English version shall prevail in case of any discrepancy between the translated and English versions.

Security — Customer understands that all NXP products may be subject to unidentified or documented vulnerabilities. Customer is responsible for the design and operation of its applications and products throughout their lifecycles to reduce the effect of these vulnerabilities on customer's applications and products. Customer's responsibility also extends to other open and/or proprietary technologies supported by NXP products for use in customer's applications. NXP accepts no liability for any vulnerability. Customer should regularly check security updates from NXP and follow up appropriately. Customer shall select products with security features that best meet rules, regulations, and standards of the intended application and make the ultimate design decisions regarding its products and is solely responsible for compliance with all legal, regulatory, and security related requirements concerning its products, regardless of any information or support that may be provided by NXP. NXP has a Product Security Incident Response Team (PSIRT) (reachable at PSIRT@nxp.com) that manages the investigation, reporting, and solution release to security vulnerabilities of NXP products.

23.4 Licenses

Purchase of NXP ICs with ISO/IEC 14443 type B functionality



RATP/Innovatron Technology

This NXP Semiconductors IC is ISO/IEC 14443 Type B software enabled and is licensed under Innovatron's Contactless Card patents license for ISO/IEC 14443 B.

The license includes the right to use the IC in systems and/or end-user equipment.

Purchase of NXP ICs with NFC technology

Purchase of an NXP Semiconductors IC that complies with one of the Near Field Communication (NFC) standards ISO/IEC 18092 and ISO/IEC 21481 does not convey an implied license under any patent right infringed by implementation of any of those standards. Purchase of NXP Semiconductors IC does not include a license to any NXP patent (or other IP right) covering combinations of those products with other products, whether hardware or software.

23.5 Trademarks

Notice: All referenced brands, product names, service names and trademarks are the property of their respective owners.

- I²C-bus** — logo is a trademark of NXP B.V.
- MIFARE** — is a trademark of NXP B.V.
- DESFire** — is a trademark of NXP B.V.
- ICODE and I-CODE** — are trademarks of NXP B.V.
- MIFARE Plus** — is a trademark of NXP B.V.
- MIFARE Ultralight** — is a trademark of NXP B.V.
- MIFARE Classic** — is a trademark of NXP B.V.
- NTAG** — is a trademark of NXP B.V.
- NXP** — wordmark and logo are trademarks of NXP B.V.
- FeliCa** — is a trademark of Sony Corporation.

Tables

Tab. 1.	Quick reference data	6	Tab. 48.	SWITCH_MODE_STANDBY	81
Tab. 2.	Ordering information	7	Tab. 49.	STANDBY control parameter: Bitmask	81
Tab. 3.	Pin description VFBGA64	9	Tab. 50.	EVT_SWITCH_MODE_LPCD	82
Tab. 4.	Pin description HVQFN40	13	Tab. 51.	SWITCH_MODE_LPCD	82
Tab. 5.	Supply voltage range	27	Tab. 52.	SWITCH_MODE_DOWNLOAD	83
Tab. 6.	DPC_LOOKUP_TABLE element, defining the configuration for one dedicated VDDPA voltage	33	Tab. 53.	GET_DIE_ID	83
Tab. 7.	Dynamic power control characteristics	33	Tab. 54.	GET_VERSION	84
Tab. 8.	ARC_VDDPA (0139Eh) EEPROM configuration bit description	37	Tab. 55.	PRBS_TEST	85
Tab. 9.	ARC_RM_A106 (address 013Eh) EEPROM configuration bit description	37	Tab. 56.	RESPONSE STATUS CODES LIST	85
Tab. 10.	Low-Power Card Detection: relevant EEPROM configuration	43	Tab. 57.	IRQ EVENT LIST	87
Tab. 11.	Low-Power Card Detection - semi- autonomous mode: relevant REGISTERS	44	Tab. 58.	Register Overview	88
Tab. 12.	DEBUG SIGNALS	47	Tab. 59.	SYSTEM_CONFIG register (address 0000h) bit description	91
Tab. 13.	TRIGGER SIGNALS	49	Tab. 60.	EVENT_ENABLE register (address 0001h) bit description	91
Tab. 14.	Host interface commands	52	Tab. 61.	EVENT_STATUS register (address 0002h) bit description	92
Tab. 15.	WRITE_REGISTER	54	Tab. 62.	EMVCO_EMD_CONTROL register (address 0003h) bit description	92
Tab. 16.	WRITE_REGISTER_OR_MASK	55	Tab. 63.	FELICA_EMD_CONTROL register (address 0004h) bit description	93
Tab. 17.	WRITE_REGISTER_AND_MASK	55	Tab. 64.	RX_STATUS register (address 0005h) bit description	94
Tab. 18.	WRITE_REGISTER_MULTIPLE	56	Tab. 65.	RX_STATUS_ERROR register (address 0006h) bit description	95
Tab. 19.	READ_REGISTER	57	Tab. 66.	CLIF_STATUS register (address 0007h) bit description	97
Tab. 20.	READ_REGISTER_MULTIPLE	57	Tab. 67.	RF_EXCHANGE_CONTROL register (address 0008h) bit description	98
Tab. 21.	WRITE_EEPROM	58	Tab. 68.	TX_SYMBOL01_MOD register (address 0009h) bit description	99
Tab. 22.	READ_EEPROM	59	Tab. 69.	TX_SYMBOL1_DEF register (address 000Ah) bit description	99
Tab. 23.	TANSMIT_RF_DATA	60	Tab. 70.	TX_SYMBOL0_DEF register (address 000Bh) bit description	100
Tab. 24.	RETRIEVE_RF_DATA	60	Tab. 71.	TX_SYMBOL23_MOD register (address 000Ch) bit description	100
Tab. 25.	EXCHANGE_RF_DATA	61	Tab. 72.	TX_SYMBOL23_DEF register (address 000Dh) bit description	100
Tab. 26.	EXCHANGE_RF_DATA Parameter RF Exchange Config: Bitmask	62	Tab. 73.	TX_SYMBOL_CONFIG register (address 000Eh) bit description	100
Tab. 27.	MFC_AUTHENTICATE	62	Tab. 74.	TX_FRAME_CONFIG register (address 000Fh) bit description	101
Tab. 28.	EPC_GEN2_INVENTORY	64	Tab. 75.	TX_DATA_MOD register (address 0010h) bit description	102
Tab. 29.	LOAD_RF_CONFIGURATION	66	Tab. 76.	TX_CLIF_WAIT register (address 0011h) bit description	103
Tab. 30.	TX Parameter for command LOAD_RF_ CONFIGURATION	66	Tab. 77.	TX_CRC_CONFIG (address 0012h) bit description	104
Tab. 31.	RX Parameter for command LOAD_RF_ CONFIGURATION	67	Tab. 78.	SS_TX_CONFIG register (address 0015h) bit description	104
Tab. 32.	UPDATE_RF_CONFIGURATION	69	Tab. 79.	SS_TX1_RMCFG register (address 0016h) bit description	105
Tab. 33.	GET_RF_CONFIGURATION	69	Tab. 80.	SS_TX2_RMCFG register (address 0017h) bit description	105
Tab. 34.	RF_ON	70			
Tab. 35.	RF_OFF	71			
Tab. 36.	RF_OFF	71			
Tab. 37.	RF_OFF	72			
Tab. 38.	CTS_ENABLE	73			
Tab. 39.	CTS_CONFIGURE	73			
Tab. 40.	CTS_RETRIEVE_LOG	77			
Tab. 41.	RECEIVE_RF_DATA	78			
Tab. 42.	EVT_SWITCH_MODE_NORMAL	79			
Tab. 43.	SWITCH_MODE_NORMAL	79			
Tab. 44.	EVT_SWITCH_MODE_AUTOCOLL	79			
Tab. 45.	SWITCH_MODE_AUTOCOLL	80			
Tab. 46.	RF Technologies parameter: Bitmask	80			
Tab. 47.	EVT_SWITCH_MODE_STANDBY	81			

Tab. 81.	SS_TX_TRANS_CFG register (address 0019h) bit description	106	Tab. 110.	RXM_RSSI register (address 005Ah) bit description	118
Tab. 82.	SIGPRO_RM_PATTERN register (address 0020h) bit description	106	Tab. 111.	TEMP_SENSOR register (address 005Bh) bit description	119
Tab. 83.	SIGPRO_RM_TECH register (address 0022h) bit description	106	Tab. 112.	TX_NOV_CALIBRATE register (address 005Dh) bit description	119
Tab. 84.	RX_FRAME_LENGTH register (address 0026h) bit description	107	Tab. 113.	SS_TX1_RTRTRANS0 register (address 0080h) bit description	119
Tab. 85.	RX_ERROR_CONFIG register (address 0027h) bit description	107	Tab. 114.	SS_TX1_RTRTRANS1 register (address 0081h) bit description	119
Tab. 86.	RX_CTRL_STATUS register (address 0028h) bit description	107	Tab. 115.	SS_TX1_RTRTRANS2 register (address 0082h) bit description	120
Tab. 87.	SIGPRO_IIR_CONFIG0 register (address 002Ah) bit description	108	Tab. 116.	SS_TX1_RTRTRANS0 register (address 0080h) bit description	120
Tab. 88.	DGRM_RSSI register (address 0030h) bit description	108	Tab. 117.	SS_TX2_RTRTRANS0 register (address 00804) bit description	120
Tab. 89.	RX_CRC_CONFIG register (address 0031h) bit description	108	Tab. 118.	SS_TX2_RTRTRANS1 register (address 0085h) bit description	120
Tab. 90.	RX_WAIT register (address 0032h) bit description	109	Tab. 119.	SS_TX2_RTRTRANS2 register (address 0086h) bit description	121
Tab. 91.	RXM_CTRL register (address 0035h) bit description	110	Tab. 120.	SS_TX2_RTRTRANS3 register (address 0087h) bit description	121
Tab. 92.	SS_TX1_CMCFG register (address 003Bh) bit description	110	Tab. 121.	SS_TX1_FTRTRANS0 register (address 0088h) bit description	121
Tab. 93.	SS_TX2_CMCFG register (address 003Ch) bit description	110	Tab. 122.	SS_TX1_FTRTRANS1 register (address 0089h) bit description	121
Tab. 94.	TIMER0_CONFIG register (address 003Dh) bit description	110	Tab. 123.	SS_TX1_FTRTRANS2 register (address 008Ah) bit description	121
Tab. 95.	TIMER0_RELOAD register (address 003Eh) bit description	111	Tab. 124.	SS_TX1_FTRTRANS3 register (address 008Bh) bit description	122
Tab. 96.	TIMER1_CONFIG register (address 003Fh) bit description	111	Tab. 125.	SS_TX2_FTRTRANS0 register (address 008Ch) bit description	122
Tab. 97.	TIMER1_RELOAD register (address 0040h) bit description	113	Tab. 126.	SS_TX2_FTRTRANS1 register (address 008Dh) bit description	122
Tab. 98.	EMD_1_CFG register (address 0047h) bit description	113	Tab. 127.	SS_TX2_FTRTRANS2 register (address 008Eh) bit description	122
Tab. 99.	EMD_0_CONFIG register (address 0048h) bit description	114	Tab. 128.	SS_TX2_FTRTRANS3 register (address 008Fh) bit description	123
Tab. 100.	LPCD_CALIBRATE_CTRL register (address 0050h) bit description	114	Tab. 129.	EEPROM CONFIGURATION REGISTER	123
Tab. 101.	IQ_CHANNEL_VALS register (address 0051h) bit description	114	Tab. 130.	PWR_CONFIG (address 0000h) EEPROM configuration bit description	129
Tab. 102.	PAD_CONFIG register (address 0052h) bit description	114	Tab. 131.	DCDC_CONFIG (address 0001h) EEPROM configuration bit description	129
Tab. 103.	CALIBRATE_STATUS register (address 0053h) bit description	115	Tab. 132.	TXLDO_CONFIG (address 0002h) EEPROM configuration bit description	130
Tab. 104.	TXLDO_VDDPA_CONFIG register (address 0054h) bit description	115	Tab. 133.	TXLDO_VDDPA_HIGH (address 0006h) EEPROM configuration bit description	131
Tab. 105.	GENERAL_ERROR_STATUS register (address 0055h) bit description	116	Tab. 134.	TXLDO_VDDPA_LOW (address 0007h) EEPROM configuration bit description	132
Tab. 106.	TXLDO_VOUT_CURR register (address 0056h) bit description	116	Tab. 135.	TXLDO_VDDPA_MAX_RDR (address 0008h) EEPROM configuration bit description	133
Tab. 107.	CLIF_DAC register (address 0057h) bit description	117	Tab. 136.	TXLDO_VDDPA_MAX_CARD (address 0009h) EEPROM configuration bit description	134
Tab. 108.	PMU_ANA_SMPS_CTRL_REG register (address 0058h) bit description	118	Tab. 137.	BOOST_DEFAULT_VOLTAGE (address 000Ah) EEPROM configuration bit description	135
Tab. 109.	RXM_FREQ register (address 0059h) bit description	118			

Tab. 138.	XTAL_CONFIG (address 0010h) EEPROM configuration bit description	135	Tab. 164.	RESIDUAL_AMPL_LEVEL_B212 (address 0036h) EEPROM configuration bit description	146
Tab. 139.	XTAL_TIMEOUT (address 0011h) EEPROM configuration bit description	136	Tab. 165.	EDGE_TYPE_B212 (address 0037h) EEPROM configuration bit description	146
Tab. 140.	CLK_INPUT_FREQ (address 0012h) EEPROM configuration bit description	136	Tab. 166.	EDGE_STYLE_B212 (address 0038h) EEPROM configuration bit description	146
Tab. 141.	XTAL_CHECK_DELAY (address 0013h) EEPROM configuration bit description	136	Tab. 167.	EDGE_LENGTH_B212 (address 0039h) EEPROM configuration bit description	147
Tab. 142.	TEMP_WARNING (address 0014h) EEPROM configuration bit description	137	Tab. 168.	RESIDUAL_AMPL_LEVEL_B424 (address 003Ah) EEPROM configuration bit description	147
Tab. 143.	ENABLE_GPIO0_ON_OVERTEMP (address 0016h) EEPROM configuration bit description	137	Tab. 169.	EDGE_TYPE_B424 (address 003Bh) EEPROM configuration bit description	148
Tab. 144.	RESIDUAL_AMPL_LEVEL_A106 (address 0022h) EEPROM configuration bit description	137	Tab. 170.	EDGE_STYLE_B424 (address 003Ch) EEPROM configuration bit description	148
Tab. 145.	EDGE_TYPE_A106 (address 0023h) EEPROM configuration bit description	138	Tab. 171.	EDGE_LENGTH_B424 (address 003Dh) EEPROM configuration bit description	149
Tab. 146.	EDGE_STYLE_A106 (address 0024h) EEPROM configuration bit description	138	Tab. 172.	RESIDUAL_AMPL_LEVEL_B848 (address 003Eh) EEPROM configuration bit description	149
Tab. 147.	EDGE_LENGTH_A106 (address 0025h) EEPROM configuration bit description	139	Tab. 173.	EDGE_TYPE_B848 (address 003Fh) EEPROM configuration bit description	149
Tab. 148.	RESIDUAL_AMPL_LEVEL_A212 (address 0026h) EEPROM configuration bit description	139	Tab. 174.	EDGE_STYLE_B848 (address 0040h) EEPROM configuration bit description	150
Tab. 149.	EDGE_TYPE_A212 (address 0027h) EEPROM configuration bit description	139	Tab. 175.	EDGE_LENGTH_B848 (address 0041h) EEPROM configuration bit description	150
Tab. 150.	EDGE_STYLE_A212 (address 0028h) EEPROM configuration bit description	140	Tab. 176.	RESIDUAL_AMPL_LEVEL_F212 (address 0042h) EEPROM configuration bit description	151
Tab. 151.	EDGE_LENGTH_A212 (address 0029h) EEPROM configuration bit description	140	Tab. 177.	EDGE_TYPE_F212 (address 0043h) EEPROM configuration bit description	151
Tab. 152.	RESIDUAL_AMPL_LEVEL_A424 (address 002Ah) EEPROM configuration bit description	141	Tab. 178.	EDGE_STYLE_F212 (address 0044h) EEPROM configuration bit description	151
Tab. 153.	EDGE_TYPE_A424 (address 002Bh) EEPROM configuration bit description	141	Tab. 179.	EDGE_LENGTH_F212 (address 0045h) EEPROM configuration bit description	152
Tab. 154.	EDGE_STYLE_A424 (address 002Ch) EEPROM configuration bit description	141	Tab. 180.	RESIDUAL_AMPL_LEVEL_F424 (address 0046h) EEPROM configuration bit description	152
Tab. 155.	EDGE_LENGTH_A424 (address 002Ch) EEPROM configuration bit description	142	Tab. 181.	EDGE_TYPE_F424 (address 0047h) EEPROM configuration bit description	153
Tab. 156.	RESIDUAL_AMPL_LEVEL_A848 (address 002Eh) EEPROM configuration bit description	142	Tab. 182.	EDGE_STYLE_F424 (address 0048h) EEPROM configuration bit description	153
Tab. 157.	EDGE_TYPE_A848 (address 002Fh) EEPROM configuration bit description	143	Tab. 183.	EDGE_LENGTH_F424 (address 0049h) EEPROM configuration bit description	154
Tab. 158.	EDGE_STYLE_A848 (address 0030h) EEPROM configuration bit description	143	Tab. 184.	RESIDUAL_AMPL_LEVEL_V100_26 (address 004Ah) EEPROM configuration bit description	154
Tab. 159.	EDGE_LENGTH_A848 (address 0031h) EEPROM configuration bit description	144	Tab. 185.	EDGE_TYPE_V100_26 (address 004Bh) EEPROM configuration bit description	154
Tab. 160.	RESIDUAL_AMPL_LEVEL_B106 (address 0032h) EEPROM configuration bit description	144	Tab. 186.	EDGE_STYLE_V100_26 (address 004Ch) EEPROM configuration bit description	155
Tab. 161.	EDGE_TYPE_B106 (address 0033h) EEPROM configuration bit description	144	Tab. 187.	EDGE_LENGTH_V100_26 (address 004Dh) EEPROM configuration bit description	155
Tab. 162.	EDGE_STYLE_B106 (address 0034h) EEPROM configuration bit description	145	Tab. 188.	RESIDUAL_AMPL_LEVEL_V100_53 (address 004Eh) EEPROM configuration bit description	156
Tab. 163.	EDGE_LENGTH_B106 (address 0035h) EEPROM configuration bit description	145			

Tab. 189.	EDGE_TYPE_V100_53 (address 004Fh) EEPROM configuration bit description	156	Tab. 213.	EDGE_TYPE_V10_212 (address 0067h) EEPROM configuration bit description	166
Tab. 190.	EDGE_STYLE_A106 (address 0050h) EEPROM configuration bit description	156	Tab. 214.	EDGE_STYLE_V10_212 (address 0068h) EEPROM configuration bit description	166
Tab. 191.	EDGE_LENGTH_V100_53 (address 0051h) EEPROM configuration bit description	157	Tab. 215.	EDGE_LENGTH_V100_212 (address 0069h) EEPROM configuration bit description	167
Tab. 192.	RESIDUAL_AMPL_LEVEL_V100_106 (address 0052h) EEPROM configuration bit description	157	Tab. 216.	RESIDUAL_AMPL_LEVEL_180003m3_ tari18p88 (address 006Ah) EEPROM configuration bit description	167
Tab. 193.	EDGE_TYPE_V100_106 (address 0053h) EEPROM configuration bit description	158	Tab. 217.	EDGE_TYPE_180003m3_tari18p88 (address 006Bh) EEPROM configuration bit description	168
Tab. 194.	EDGE_STYLE_V100_106 (address 0054h) EEPROM configuration bit description	158	Tab. 218.	EDGE_STYLE_180003m3_tari18p88 (address 006Ch) EEPROM configuration bit description	168
Tab. 195.	EDGE_LENGTH_V100_106 (address 0055h) EEPROM configuration bit description	159	Tab. 219.	EDGE_LENGTH_180003m3_tari18p88 (address 006Dh) EEPROM configuration bit description	169
Tab. 196.	RESIDUAL_AMPL_LEVEL_100_212 (address 0056h) EEPROM configuration bit description	159	Tab. 220.	RESIDUAL_AMPL_LEVEL_180003m3_ tari9p44 (address 006Eh) EEPROM configuration bit description	169
Tab. 197.	EDGE_TYPE_V100_212 (address 0057h) EEPROM configuration bit description	159	Tab. 221.	EDGE_TYPE_180003m3_tari9p44 (address 006Fh) EEPROM configuration bit description	169
Tab. 198.	EDGE_STYLE_V100_212 (address 0058h) EEPROM configuration bit description	160	Tab. 222.	EDGE_STYLE_180003m3_tari9p44 (address 0070h) EEPROM configuration bit description	170
Tab. 199.	EDGE_LENGTH_V100_212 (address 0059h) EEPROM configuration bit description	160	Tab. 223.	EDGE_LENGTH_180003m3_tari9p44 (address 0071h) EEPROM configuration bit description	170
Tab. 200.	RESIDUAL_AMPL_LEVEL_V10_26 (address 005Ah) EEPROM configuration bit description	161	Tab. 224.	RESIDUAL_AMPL_LEVEL_180003m3_ tari18p88 (address 0072h) EEPROM configuration bit description	171
Tab. 201.	EDGE_TYPE_V10_26 (address 005Bh) EEPROM configuration bit description	161	Tab. 225.	EDGE_TYPE_B_PRIME_106 (address 0073h) EEPROM configuration bit description	171
Tab. 202.	EDGE_STYLE_V10_26 (address 005Ch) EEPROM configuration bit description	161	Tab. 226.	EDGE_STYLE_B_PRIME_106 (address 0074h) EEPROM configuration bit description	171
Tab. 203.	EDGE_LENGTH_V10_26 (address 005Dh) EEPROM configuration bit description	162	Tab. 227.	EDGE_LENGTH_B_PRIME_106 (address 0075h) EEPROM configuration bit description	172
Tab. 204.	RESIDUAL_AMPL_LEVEL_V10_53 (address 005Eh) EEPROM configuration bit description	162	Tab. 228.	DPC_CONFIG (address 0076h) EEPROM configuration bit description	172
Tab. 205.	EDGE_TYPE_V10_53 (address 005Fh) EEPROM configuration bit description	163	Tab. 229.	DPC_TARGET_CURRENT (address 077h) EEPROM configuration bit description	173
Tab. 206.	EDGE_STYLE_V10_53 (address 0060h) EEPROM configuration bit description	163	Tab. 230.	DPC_HYSTERESIS_LOADING (address 079h) EEPROM configuration bit description	173
Tab. 207.	EDGE_LENGTH_V10_53 (address 0061h) EEPROM configuration bit description	164	Tab. 231.	DPC_HYSTERESIS_UNLOADING (address 07Ch) EEPROM configuration bit description	173
Tab. 208.	RESIDUAL_AMPL_LEVEL_V10_106 (address 0062h) EEPROM configuration bit description	164	Tab. 232.	DPC_TXLDOVDDPALow (address 007Dh) EEPROM configuration register bit description	174
Tab. 209.	EDGE_TYPE_V10_106 (address 0063h) EEPROM configuration bit description	164	Tab. 233.	DPC_TXGSN (address 007Eh) EEPROM configuration register bit description	174
Tab. 210.	EDGE_STYLE_V100_212 (address 0064h) EEPROM configuration bit description	165			
Tab. 211.	EDGE_LENGTH_V10_106 (address 0065h) EEPROM configuration bit description	165			
Tab. 212.	RESIDUAL_AMPL_LEVEL_V10_212 (address 0066h) EEPROM configuration bit description	166			

Tab. 234. DPC_RDON_Control (address 007Fh) EEPROM configuration register bit description 174	Tab. 260. ARC_RM_180003m3_SC848_2Man (address 01F2h) EEPROM configuration bit description 205
Tab. 235. DPC_InitialRDOOn_RFOOn (address 0080h) EEPROM configuration register bit description 174	Tab. 261. ARC_RM_AI106 (address 01FCh) EEPROM configuration bit description 206
Tab. 236. DPC_GUARD_TIME (address 087h) EEPROM configuration bit description 174	Tab. 262. ARC_RM_AI212 (0206h) EEPROM configuration bit description208
Tab. 237. DPC_ENABLE_DURING_FDT (address 088h) EEPROM configuration bit description 175	Tab. 263. ARC_RM_AI424 (0210h) EEPROM configuration bit description209
Tab. 238. DPC_GUARD_TIME_AFTER_RX (address 089h) EEPROM configuration bit description 175	Tab. 264. RF_DEBOUNCE_TIMEOUT (address 02B2h) EEPROM configuration bit description 210
Tab. 239. DPC_LOOKUP_TABLE (008Bh-0133h) EEPROM configuration bit description 175	Tab. 265. SENSE_RES (address 02B3) EEPROM configuration bit description211
Tab. 240. ARC_CONFIG (address 0137h) EEPROM configuration bit description176	Tab. 266. SIGNAL_SCALING_CONFIG (address 2B5h) EEPROM configuration bit description 211
Tab. 241. ARC_VDDPA (0139Eh) EEPROM configuration bit description176	Tab. 267. SEL_RES (address 2B8h) EEPROM configuration bit description211
Tab. 242. ARC_RM_AI106 (address 013Eh) EEPROM configuration bit description 178	Tab. 268. FELICA_POLL_RES (address 02B9) EEPROM configuration bit description 211
Tab. 243. ARC_RM_AI212 (address 0148h) EEPROM configuration bit description179	Tab. 269. RANDOM_UID_ENABLE (address 2CBh) EEPROM configuration bit description 212
Tab. 244. ARC_RM_AI424 (address 0152h) EEPROM configuration bit description181	Tab. 270. MFC_AUTH_TIMEOUT (address 2CCh) EEPROM configuration bit description 212
Tab. 245. ARC_RM_A848 (address 015Ch) EEPROM configuration bit description 182	Tab. 271. RSSI_TIMER (address 2DAh) EEPROM configuration bit description212
Tab. 246. ARC_RM_B106 (address 0166h) EEPROM configuration bit description184	Tab. 272. RSSI_TIMER_FIRST_PERIOD (address 2DCh) EEPROM configuration bit description 212
Tab. 247. ARC_RM_B212 (address 0170h) EEPROM configuration bit description185	Tab. 273. RSSI_CTRL_00_AB (address 2DEh) EEPROM configuration bit description 212
Tab. 248. ARC_RM_B424 (address 017Ah) EEPROM configuration bit description 187	Tab. 274. RSSI_NB_ENTRIES_AB (address 2DFh) EEPROM configuration bit description 213
Tab. 249. ARC_RM_B848 (address 0184h) EEPROM configuration bit description188	Tab. 275. RSSI_THRESHOLD_PHASE_TABLE (address 2E0h) EEPROM configuration bit description 213
Tab. 250. ARC_RM_F212 (address 018Eh) EEPROM configuration bit description 190	Tab. 276. TX_PARAM_ENTRY_TABLE (address 3A2h) EEPROM configuration bit description 214
Tab. 251. ARC_RM_F424 (address 0198h) EEPROM configuration bit description191	Tab. 277. LPCD_AVG_SAMPLES (address 0492h) EEPROM configuration bit description 218
Tab. 252. ARC_RM_V_6p6 (address 01A2h) EEPROM configuration bit description 193	Tab. 278. LPCD_RSSI_TARGET (address 0494h) EEPROM configuration bit description 218
Tab. 253. ARC_RM_V_26 (address 01ACh) EEPROM configuration bit description 194	Tab. 279. LPCD_RSSI_HYST (address 0496h) EEPROM configuration bit description 218
Tab. 254. ARC_RM_V53(address 01B6h) EEPROM configuration bit description196	Tab. 280. LPCD_CONFIG (address 0497h) EEPROM configuration register bit description218
Tab. 255. ARC_RM_V106(address 01C0h) EEPROM configuration bit description197	Tab. 281. LPCD_THRESHOLD_COARSE (address 049Ah) EEPROM configuration bit description 219
Tab. 256. ARC_RM_V212(address 01CAh) EEPROM configuration bit description199	Tab. 282. LPCD_VDDPA (address 04B5h) EEPROM configuration bit description220
Tab. 257. ARC_RM_180003m3_SC424_4Man (address 01D4h) EEPROM configuration bit description200	Tab. 283. ULPCD_VDDPA_CTRL (address 4BFh) EEPROM configuration bit description 221
Tab. 258. ARC_RM_180003m3_SC424_2Man (address 01DEh) EEPROM configuration bit description 202	Tab. 284. ULPCD_TIMING_CTRL (address 4C2h) EEPROM configuration bit description 222
Tab. 259. ARC_RM_180003m3_SC848_4Man (address 01E8h) EEPROM configuration bit description203	Tab. 285. ULPCD_VOLTAGE_CTRL (address 4C6h) EEPROM configuration bit description 222

Tab. 286. ULPCD_RSSI_GUARD_TIME (address 4C9h) EEPROM configuration bit description	222	Tab. 307. Tx_Symbol23_Mod_Reg_BR_106 (0CCDEh) EEPROM configuration bit description	230
Tab. 287. ULPCD_RSSI_SAMPLE_CFG (address 4CAh) EEPROM configuration bit description	222	Tab. 308. Tx_Data_Mod_Reg_BR_106 (0CD1Eh) EEPROM configuration bit description	230
Tab. 288. ULPCD_THRESH_LVL (address 4CBh) EEPROM configuration bit description	223	Tab. 309. Tx_Symbol23_Mod_Reg_BR_212 (0CD5Eh) EEPROM configuration bit description	230
Tab. 289. ULPCD_GPIO3 (address 4CCh) EEPROM configuration bit description	223	Tab. 310. Tx_Data_Mod_Reg_BR_212 (0CD9Eh) EEPROM configuration bit description	230
Tab. 290. FELICA_POLL_RES (address 0559) EEPROM configuration bit description	223	Tab. 311. Limiting values	231
Tab. 291. FDT_default_val (address 055D) EEPROM configuration bit description	223	Tab. 312. Operating conditions	232
Tab. 292. RXIRQ_GuardTime (address 0561h) EEPROM configuration bit description	223	Tab. 313. Thermal characteristics HVQFN40 package ..	232
Tab. 293. NFCLD_RFLD_Valid (address 06D3h) EEPROM configuration register bit description	224	Tab. 314. Thermal characteristics VFBGA64 package ..	232
Tab. 294. CurrentSensorTrimConfig (address 0CACH) EEPROM configuration bit description	224	Tab. 315. Junction Temperature	232
Tab. 295. CORRECTION_ENTRY_TABLE (address 0BDAh) EEPROM configuration bit description	224	Tab. 316. Thermal Shutdown Temperature	233
Tab. 296. RTRANS_FTRANS_TABLE (address C03h) EEPROM configuration bit description	226	Tab. 317. Supply voltage	233
Tab. 297. CFG_NOV_CAL (address 0083h) EEPROM configuration bit description	227	Tab. 318. Current consumption in active mode	233
Tab. 298. NOV_CAL_VAL1 (address 0C84h) EEPROM configuration bit description	227	Tab. 319. Current consumption during power-saving modes	234
Tab. 299. NOV_CAL_VAL2 (0C85h) EEPROM configuration bit description	227	Tab. 320. Overcurrent detection function	234
Tab. 300. NOV_CAL_THRESHOLD (address 0C86h) EEPROM configuration bit description	228	Tab. 321. VEN pin	235
Tab. 301. NOV_CAL_OFFSET1 (address 0C87h) EEPROM configuration bit description	228	Tab. 322. GPIO (GPIO_0, GPIO_1, GPIO_2, GPIO_3, GPIO4, GPIO5) pins	235
Tab. 302. NOV_CAL_OFFSET1 (address 0C8Bh) EEPROM configuration bit description	228	Tab. 323. CLK1, CLK2 pins	235
Tab. 303. VDDPA_DISCHARGE (address 0C8Fh) EEPROM configuration bit description	228	Tab. 324. IRQ pin	236
Tab. 304. ARC_RM_A106_FDT (address 0C9Dh) EEPROM configuration bit description	229	Tab. 325. SCLK, MOSI, NSS pins	236
Tab. 305. Tx_Symbol23_Mod_Reg_BR_53 (0CC5Eh) EEPROM configuration bit description	230	Tab. 326. MISO pin	236
Tab. 306. Tx_Data_Mod_Reg_BR_53 (0CC9Eh) EEPROM configuration bit description	230	Tab. 327. RXp, RXn pins	237
		Tab. 328. TX1, TX2 pins	237
		Tab. 329. AUX1, AUX2, AUX3 pins (Debug output)	237
		Tab. 330. DAC_1, DAC_2 output pins (Tuning DAC)	237
		Tab. 331. Power supply connection timing	238
		Tab. 332. Pulse length	239
		Tab. 333. DAC1, DAC2 conversion timing (Tuning DAC)	239
		Tab. 334. SPI interface	239
		Tab. 335. RF_ON command timing following a previous RF_OFF	240
		Tab. 336. Crystal requirements for ISO/IEC14443 compliant operation	240
		Tab. 337. Frequency requirements for a direct clock input (no crystal)	240
		Tab. 338. EEPROM characteristics	241
		Tab. 339. Package outline VFBGA64 (SOT1307-2)	242
		Tab. 340. Abbreviations	293
		Tab. 341. Revision history	295

Figures

Fig. 1.	Block diagram	8	Fig. 24.	LPCD configuration and card detection loop	41
Fig. 2.	Pin configuration for VFBGA64	9	Fig. 25.	LPCD configuration	42
Fig. 3.	Pin configuration for HVQFN40 (SOT2062-1)	13	Fig. 26.	Autocall state machine	45
Fig. 4.	Endianness examples	18	Fig. 27.	Antenna connection using variable capacitors	47
Fig. 5.	Blocking capacitors	21	Fig. 28.	Receiver block diagram	47
Fig. 6.	Transmitter supply	22	Fig. 29.	Startup timing	238
Fig. 7.	Direct transmitter supply	23	Fig. 30.	Package outline VFBGA64 (SOT1307-2)	242
Fig. 8.	Transmitter supply by DC-DC	23	Fig. 31.	Package outline note VFBGA64 (SOT1307-2)	243
Fig. 9.	DC-DC active	24	Fig. 32.	Package outline HVQFN40, SOT2062-1	244
Fig. 10.	DC-DC bypassed (in DCDC_PWR_CONFIG)	24	Fig. 33.	Package outline detail HVQFN40, SOT2062-1	245
Fig. 11.	No DC-DC used	25	Fig. 34.	Marking VFBGA64 Package	246
Fig. 12.	No DC-DC used	25	Fig. 35.	Marking HVQFN40 package SOT2062-1	246
Fig. 13.	No DC-DC used - no VDDPALDO	26	Fig. 36.	Reflow soldering footprint part1 for VFBGA64 (SOT1307-2)	247
Fig. 14.	Clocking by crystal	27	Fig. 37.	Reflow soldering footprint part2 for VFBGA64 (SOT1307-2)	248
Fig. 15.	System overview: DPC, AWC and ARC	30	Fig. 38.	Reflow soldering footprint part3 for VFBGA64 (SOT1307-2)	249
Fig. 16.	System overview: DPC, AWC and ARC	31	Fig. 39.	Soldering and footprint representative illustration for VFBGA64 (SOT1307-2)	250
Fig. 17.	System overview: DPC, AWC and ARC	31	Fig. 40.	Package outline HVQFN40, SOT2062-1	251
Fig. 18.	System overview: DPC, AWC and ARC	32	Fig. 41.	Package outline HVQFN40, SOT2062-1	252
Fig. 19.	Waveshaping transitions (example falling edge)	34	Fig. 42.	Package outline HVQFN40, SOT2062-1	253
Fig. 20.	One linear transition (example falling edge)	35	Fig. 43.	Package outline HVQFN40, SOT2062-1	254
Fig. 21.	Two linear transitions (example falling edge)	36			
Fig. 22.	Three linear transitions (example falling edge)	36			
Fig. 23.	Timer overview	40			

Contents

1	General description	1	9.14	Low-power card detection	40
2	Features and benefits	2	9.14.1	Low-power card detection (LPCD)	41
2.1	RF functionality	2	9.14.2	Semi-autonomous mode (LPCD)	43
2.1.1	ISO/IEC14443-A	2	9.15	Automatic EMD error handling	44
2.1.2	ISO/IEC14443-B	2	9.16	Autocoll (card emulation)	44
2.1.3	FeliCa	2	9.17	RF-level detection	46
2.1.4	Tag type reading	2	9.18	Antenna tuning with variable capacitors	46
2.1.5	MIFARE card reading	2	9.19	RF debug signals	47
2.1.6	ISO/IEC 15693	2	9.20	Secure firmware update	49
2.1.7	Peer to peer	2	9.21	SPI host interface	50
2.2	Host interface	3	9.22	Host interface commands	51
3	Applications	4	9.22.1	Logical command layer	51
4	Firmware versions	5	9.22.1.1	Logical frame definition	51
5	Quick reference data	6	9.22.1.2	Logical flow definition	51
6	Ordering information	7	9.22.1.3	Logical message type definition	51
7	Block diagram with VFBGA64 connections	8	9.22.1.4	Logical message format	52
8	Pinning information	9	9.22.1.5	Split frame definition	52
8.1	Pin description VFBGA64	9	9.22.2	Host interface command list	52
8.2	Pin description HVQFN40	13	9.22.3	Command WRITE_REGISTER (00h)	54
9	Functional description	15	9.22.4	Command WRITE_REGISTER_OR_MASK (01h)	54
9.1	Functional overview	15	9.22.5	Command WRITE_REGISTER_AND_MASK (02h)	55
9.2	Endianness	17	9.22.6	Command WRITE_REGISTER_MULTIPLE (03h)	55
9.3	Initial calibration	18	9.22.7	Command READ_REGISTER (04h)	56
9.4	System power states	19	9.22.8	Command READ_REGISTER_MULTIPLE (05h)	57
9.5	Power supply	20	9.22.9	Command WRITE_EEPROM (06h)	58
9.5.1	System power supply overview	20	9.22.10	Command READ_EEPROM (07h)	59
9.5.2	Connecting blocking capacitors	21	9.22.11	Command TRANSMIT_RF_DATA (08h)	59
9.5.3	Transmitter power supply	21	9.22.12	Command RETRIEVE_RF_DATA (09h)	60
9.5.3.1	VDDPALDO transmitter supply	22	9.22.13	Command EXCHANGE_RF_DATA (0Ah)	60
9.5.3.2	Direct transmitter supply	22	9.22.14	Command MFC_AUTHENTICATE (0Bh)	62
9.5.3.3	DC-DC (boost) supply	23	9.22.15	Command EPC_GEN2_INVENTORY (0Ch)	63
9.5.3.4	Configuration example 1: VDDPALDO transmitter supply - DC-DC active	23	9.22.16	Command LOAD_RF_CONFIGURATION (0Dh)	65
9.5.3.5	Configuration example 2: VDDPALDO transmitter supply - DC-DC bypassed	24	9.22.16.1	Parameter for command LOAD_RF_CONFIGURATION	66
9.5.3.6	Configuration example 3: VDDPALDO transmitter supply connected to VBAT - no DC-DC	24	9.22.17	Command UPDATE_RF_CONFIGURATION (0Eh)	68
9.5.3.7	Configuration example 4: VDDPALDO supplied independent from VBAT - no DC-DC	25	9.22.18	Command GET_RF_CONFIGURATION (0Fh)	69
9.5.3.8	Configuration example 5: VDDPALDO not used - no DC-DC	25	9.22.19	Command RF_ON (10h)	70
9.5.3.9	Supply voltage range for transmitter supply configuration examples	27	9.22.20	Command RF_OFF (11h)	70
9.6	Clock generation	27	9.22.21	Command CONFIGURE_TESTBUS_DIGITAL (12h)	71
9.7	External interfaces	27	9.22.22	Command CONFIGURE_TESTBUS_ANALOG (13h)	72
9.8	Transmitter overcurrent and temperature protection	28	9.22.23	Command CTS_ENABLE (14h)	72
9.9	Loading a dedicated RF configuration	28	9.22.24	Command CTS_CONFIGURE (15h)	73
9.10	Dynamic power control (DPC)	28	9.22.25	Command CTS_RETRIEVE_LOG (16h)	77
9.10.1	DPC algorithm	32	9.22.26	Command RECEIVE_RF_DATA (1Ah)	77
9.10.2	DPC characteristics	33	9.22.27	Command SWITCH_MODE_NORMAL (20h)	78
9.11	Adaptive waveshape control (AWC)	34			
9.12	Adaptive receiver control (ARC)	36			
9.13	Timer	39			

9.22.28	Command SWITCH_MODE_AUTOCOLL (21h)	79	9.23.46	CALIBRATE_STATUS (00053h)	115
9.22.29	Command SWITCH_MODE_STANDBY (22h)	81	9.23.47	TXLDO_VDDPA_CONFIG (00054h)	115
9.22.30	Command SWITCH_MODE_LPCD (23h)	81	9.23.48	GENERAL_ERROR_STATUS (0055h)	116
9.22.31	Command SWITCH_MODE_DOWNLOAD (25h)	82	9.23.49	TXLDO_VOUT_CURR (0056h)	116
9.22.32	Command GET_DIE_ID (26h)	83	9.23.50	CLIF_DAC (00057h)	117
9.22.33	Command GET_VERSION (27h)	83	9.23.51	PMU_ANA_SMPS_CTRL_REG (00058h)	118
9.22.34	Command PRBS_TEST (41h)	84	9.23.52	RXM_FREQ (00059h)	118
9.22.35	RESPONSE STATUS CODES	85	9.23.53	RXM_RSSI (0005Ah)	118
9.22.36	EVENTS INDICATED BY INTERRUPT	87	9.23.54	TEMP_SENSOR (005Bh)	119
9.22.37	EVENTS INDICATED ON GPIO	88	9.23.55	TX_NOV_CALIBRATE (005Dh)	119
9.23	Register description	88	9.23.56	SS_TX1_RTRTRANS0 (00080h)	119
9.23.1	Register overview	88	9.23.57	SS_TX1_RTRTRANS1 (00081h)	119
9.23.2	SYSTEM_CONFIG (0000h)	91	9.23.58	SS_TX1_RTRTRANS2 (00082h)	120
9.23.3	EVENT_ENABLE (0001h)	91	9.23.59	SS_TX1_RTRTRANS3 (00083h)	120
9.23.4	EVENT_STATUS (0002h)	92	9.23.60	SS_TX2_RTRTRANS0 (00084h)	120
9.23.5	EMVCO_EMD_CONTROL (0003h)	92	9.23.61	SS_TX2_RTRTRANS1 (00085h)	120
9.23.6	FELICA_EMD_CONTROL (0004h)	93	9.23.62	SS_TX2_RTRTRANS2 (00086h)	121
9.23.7	RX_STATUS (0005h)	94	9.23.63	SS_TX2_RTRTRANS3 (00087h)	121
9.23.8	RX_STATUS_ERROR (0006h)	95	9.23.64	SS_TX1_FTRTRANS0 (00088h)	121
9.23.9	CLIF_STATUS (0007h)	97	9.23.65	SS_TX1_FTRTRANS1 (00089h)	121
9.23.10	RF_EXCHANGE_CONTROL (0008h)	98	9.23.66	SS_TX1_FTRTRANS2 (0008Ah)	121
9.23.11	TX_SYMBOL01_MOD (0009h)	99	9.23.67	SS_TX1_FTRTRANS3 (0008Bh)	122
9.23.12	TX_SYMBOL1_DEF (000Ah)	99	9.23.68	SS_TX2_FTRTRANS0 (0008Ch)	122
9.23.13	TX_SYMBOL0_DEF (000Bh)	100	9.23.69	SS_TX2_FTRTRANS1 (0008Dh)	122
9.23.14	TX_SYMBOL23_MOD (000Ch)	100	9.23.70	SS_TX2_FTRTRANS2 (0008Eh)	122
9.23.15	TX_SYMBOL23_DEF (000Dh)	100	9.23.71	SS_TX2_FTRTRANS3 (0008Fh)	123
9.23.16	TX_SYMBOL_CONFIG (000Eh)	100	9.24	EEPROM configuration description	123
9.23.17	TX_FRAME_CONFIG (000Fh)	101	9.24.1	EEPROM configuration overview	123
9.23.18	TX_DATA_MOD (0010h)	102	9.24.2	DCDC_PWR_CONFIG (0000h)	129
9.23.19	TX_WAIT (0011h)	103	9.24.3	DCDC_CONFIG (0001h)	129
9.23.20	TX_CRC_CONFIG (0012h)	104	9.24.4	TXLDO_CONFIG (0002h)	130
9.23.21	SS_TX_CONFIG (00015h)	104	9.24.5	TXLDO_VDDPA_HIGH (0006h)	131
9.23.22	SS_TX1_RMCFG (00016h)	105	9.24.6	TXLDO_VDDPA_LOW (0007h)	132
9.23.23	SS_TX2_RMCFG (00017h)	105	9.24.7	TXLDO_VDDPA_MAX_RDR (0008h)	133
9.23.24	SS_TX_TRANS_CFG (00019h)	106	9.24.8	TXLDO_VDDPA_MAX_CARD (0009h)	134
9.23.25	SIGPRO_RM_PATTERN (0020h)	106	9.24.9	BOOST_DEFAULT_VOLTAGE (000Ah)	135
9.23.26	SIGPRO_RM_TECH (0022h)	106	9.24.10	XTAL_CONFIG (0010h)	135
9.23.27	RX_FRAME_LENGTH (0026h)	107	9.24.11	XTAL_TIMEOUT (0011h)	136
9.23.28	RX_ERROR_CONFIG (0027h)	107	9.24.12	CLK_INPUT_FREQ (0012h)	136
9.23.29	RX_CTRL_STATUS (0028h)	107	9.24.13	XTAL_CHECK_DELAY (0013h)	136
9.23.30	SIGPRO_IIR_CONFIG0 (0002Ah)	108	9.24.14	TEMP_WARNING (0014h)	137
9.23.31	DGRM_RSSI (0030h)	108	9.24.15	ENABLE_GPIO0_ON_OVERTEMP (0016h)	137
9.23.32	RX_CRC_CONFIG (0031h)	108	9.24.16	RESIDUAL_AMPL_LEVEL_A106 (0022h)	137
9.23.33	RX_WAIT (0032h)	109	9.24.17	EDGE_TYPE_A106 (0023h)	138
9.23.34	RXM_CTRL (0035h)	110	9.24.18	EDGE_STYLE_A106 (0024h)	138
9.23.35	SS_TX1_CMCFG (0003Bh)	110	9.24.19	EDGE_LENGTH_A106 (0025h)	139
9.23.36	SS_TX2_CMCFG (0003Ch)	110	9.24.20	RESIDUAL_AMPL_LEVEL_A212 (0026h)	139
9.23.37	TIMER0_CONFIG (003Dh)	110	9.24.21	EDGE_TYPE_A212 (0027h)	139
9.23.38	TIMER0_RELOAD (003Eh)	111	9.24.22	EDGE_STYLE_A212 (0028h)	140
9.23.39	TIMER1_CONFIG (003Fh)	111	9.24.23	EDGE_LENGTH_A212 (0029h)	140
9.23.40	TIMER1_RELOAD (0040h)	113	9.24.24	RESIDUAL_AMPL_LEVEL_A424 (002Ah)	141
9.23.41	EMD_1_CFG (0047h)	113	9.24.25	EDGE_TYPE_A424 (002Bh)	141
9.23.42	EMD_0_CONFIG (0048h)	113	9.24.26	EDGE_STYLE_A424 (002Ch)	141
9.23.43	LPCD_CALIBRATE_CTRL (00050h)	114	9.24.27	EDGE_LENGTH_A424 (002Dh)	142
9.23.44	IQ_CHANNEL_VALS (00051h)	114	9.24.28	RESIDUAL_AMPL_LEVEL_A848 (002Eh)	142
9.23.45	PAD_CONFIG (0052h)	114	9.24.29	EDGE_TYPE_A848 (002Fh)	143
			9.24.30	EDGE_STYLE_A848 (0030h)	143
			9.24.31	EDGE_LENGTH_A848 (0031h)	144

9.24.32	RESIDUAL_AMPL_LEVEL_B106 (0032h)	144	9.24.84	RESIDUAL_AMPL_LEVEL_V10_212 (0066h)	166
9.24.33	EDGE_TYPE_B106 (0033h)	144	9.24.85	EDGE_TYPE_V10_212 (0067h)	166
9.24.34	EDGE_STYLE_B106 (0034h)	145	9.24.86	EDGE_STYLE_V10_212 (0068h)	166
9.24.35	EDGE_LENGTH_B106 (0035h)	145	9.24.87	EDGE_LENGTH_V10_212 (0069h)	167
9.24.36	RESIDUAL_AMPL_LEVEL_B212 (0036h)	146	9.24.88	RESIDUAL_AMPL_LEVEL_180003m3_ tari18p88 (006Ah)	167
9.24.37	EDGE_TYPE_B212 (0037h)	146	9.24.89	EDGE_TYPE_180003m3_tari18p88 (006Bh)	168
9.24.38	EDGE_STYLE_B212 (0038h)	146	9.24.90	EDGE_STYLE_180003m3_tari18p88 (006Ch)	168
9.24.39	EDGE_LENGTH_B212 (0039h)	147	9.24.91	EDGE_LENGTH_180003m3_tari18p88 (006Dh)	169
9.24.40	RESIDUAL_AMPL_LEVEL_B424 (003Ah)	147	9.24.92	RESIDUAL_AMPL_LEVEL_180003m3_ tari9p44 (006Eh)	169
9.24.41	EDGE_TYPE_B424 (003Bh)	148	9.24.93	EDGE_TYPE_180003m3_tari9p44 (006Fh) ..	169
9.24.42	EDGE_STYLE_B424 (003Ch)	148	9.24.94	EDGE_STYLE_180003m3_tari9p44 (0070h)	170
9.24.43	EDGE_LENGTH_B424 (003Dh)	149	9.24.95	EDGE_LENGTH_180003m3_tari9p44 (0071h)	170
9.24.44	RESIDUAL_AMPL_LEVEL_B848 (003Eh)	149	9.24.96	RESIDUAL_AMPL_LEVEL_B_PRIME_106 (0072h)	171
9.24.45	EDGE_TYPE_B848 (003Fh)	149	9.24.97	EDGE_TYPE_B_PRIME_106 (0073h)	171
9.24.46	EDGE_STYLE_B848 (0040h)	150	9.24.98	EDGE_STYLE_B_PRIME_106 (0074h)	171
9.24.47	EDGE_LENGTH_B848 (0041h)	150	9.24.99	EDGE_LENGTH_B_PRIME_106 (0075h)	172
9.24.48	RESIDUAL_AMPL_LEVEL_F212 (0042h)	151	9.24.100	DPC_CONFIG (0076h)	172
9.24.49	EDGE_TYPE_F212 (0043h)	151	9.24.101	DPC_TARGET_CURRENT (077h)	173
9.24.50	EDGE_STYLE_F212 (0044h)	151	9.24.102	DPC_HYSTERESIS_LOADING (079h)	173
9.24.51	EDGE_LENGTH_F212 (0045h)	152	9.24.103	DPC_HYSTERESIS_UNLOADING (07Ch) ...	173
9.24.52	RESIDUAL_AMPL_LEVEL_F424 (0046h)	152	9.24.104	DPC_TXLDOVDDPALow (007Dh)	174
9.24.53	EDGE_TYPE_F424 (0047h)	153	9.24.105	DPC_TXGSN (007Eh)	174
9.24.54	EDGE_STYLE_F424 (0048h)	153	9.24.106	DPC_RDON_Control (007Fh)	174
9.24.55	EDGE_LENGTH_F424 (0049h)	154	9.24.107	DPC_InitialRDOOn_RFOOn (0080h)	174
9.24.56	RESIDUAL_AMPL_LEVEL_V100_26 (004Ah)	154	9.24.108	DPC_GUARD_TIME (087h)	174
9.24.57	EDGE_TYPE_V100_26 (004Bh)	154	9.24.109	DPC_ENABLE_DURING_FDT (088h)	175
9.24.58	EDGE_STYLE_V100_26 (004Ch)	155	9.24.110	DPC_GUARD_TIME_AFTER_RX (089h)	175
9.24.59	EDGE_LENGTH_V100_26 (004Dh)	155	9.24.111	DPC_LOOKUP_TABLE (008Bh-0133h)	175
9.24.60	RESIDUAL_AMPL_LEVEL_V100_53 (004Eh)	156	9.24.112	ARC_CONFIG (0137h)	176
9.24.61	EDGE_TYPE_V100_53 (004Fh)	156	9.24.113	ARC_VDDPA (0139h)	176
9.24.62	EDGE_STYLE_V100_53 (0050h)	156	9.24.114	ARC_RM_A106 (013Eh)	177
9.24.63	EDGE_LENGTH_V100_53 (0051h)	157	9.24.115	ARC_RM_A212 (0148h)	179
9.24.64	RESIDUAL_AMPL_LEVEL_V100_106 (0052h)	157	9.24.116	ARC_RM_A424 (0152h)	180
9.24.65	EDGE_TYPE_V100_106 (0053h)	158	9.24.117	ARC_RM_A848 (015Ch)	182
9.24.66	EDGE_STYLE_V100_106 (0054h)	158	9.24.118	ARC_RM_B106 (0166h)	183
9.24.67	EDGE_LENGTH_V100_106 (0055h)	159	9.24.119	ARC_RM_B212 (0170h)	185
9.24.68	RESIDUAL_AMPL_LEVEL_100_212 (0056h)	159	9.24.120	ARC_RM_B424 (017Ah)	186
9.24.69	EDGE_TYPE_V100_212 (0057h)	159	9.24.121	ARC_RM_B848 (0184h)	188
9.24.70	EDGE_STYLE_V100_212 (0058h)	160	9.24.122	ARC_RM_F212 (018Eh)	189
9.24.71	EDGE_LENGTH_V100_212 (0059h)	160	9.24.123	ARC_RM_F424 (0198h)	191
9.24.72	RESIDUAL_AMPL_LEVEL_V10_26 (005Ah)	161	9.24.124	ARC_RM_V_6p6 (01A2h)	192
9.24.73	EDGE_TYPE_V10_26 (005Bh)	161	9.24.125	ARC_RM_V_26 (01ACh)	194
9.24.74	EDGE_STYLE_V10_26 (005Ch)	161	9.24.126	ARC_RM_V53 (01B6h)	195
9.24.75	EDGE_LENGTH_V10_26 (005Dh)	162	9.24.127	ARC_RM_V106 (01C0h)	197
9.24.76	RESIDUAL_AMPL_LEVEL_V10_53 (005Eh)	162	9.24.128	ARC_RM_V212 (01CAh)	198
9.24.77	EDGE_TYPE_V10_53 (005Fh)	163	9.24.129	ARC_RM_180003m3_SC424_4Man (01D4h)	200
9.24.78	EDGE_STYLE_V10_53 (0060h)	163	9.24.130	ARC_RM_180003m3_SC424_2Man (01DEh)	201
9.24.79	EDGE_LENGTH_V10_53 (0061h)	164			
9.24.80	RESIDUAL_AMPL_LEVEL_V10_106 (0062h)	164			
9.24.81	EDGE_TYPE_V10_106 (0063h)	164			
9.24.82	EDGE_STYLE_V10_106 (0064h)	165			
9.24.83	EDGE_LENGTH_V10_106 (0065h)	165			

9.24.131	ARC_RM_180003m3_SC848_4Man (01E8h)	203	11	Characteristics	232
9.24.132	ARC_RM_180003m3_SC848_2Man (01F2h)	204	11.1	Thermal characteristics	232
9.24.133	ARC_RM_AI106 (01FCh)	206	11.2	Static characteristics	233
9.24.134	ARC_RM_AI212 (0206h)	207	11.3	Timing characteristics	237
9.24.135	ARC_RM_AI424 (0210h)	209	11.4	Clock input	240
9.24.136	RF_DEBOUNCE_TIMEOUT (02B2h)	210	11.5	EEPROM characteristics	241
9.24.137	SENSE_RES (02B3h)	211	12	Package outline	242
9.24.138	NFC_ID1 (02B5h)	211	12.1	VFPGA64 package	242
9.24.139	SEL_RES (02B8h)	211	12.2	HVQFN40 package	244
9.24.140	FELICA_POLL_RES (02B9h)	211	13	Package marking	246
9.24.141	RANDOM_UID_ENABLE (02CBh)	212	13.1	Package marking drawing VFPGA64	246
9.24.142	MFC_AUTH_TIMEOUT (02CCh)	212	13.2	Package marking drawing HVQFN40	246
9.24.143	RSSI_TIMER (02DAh)	212	14	Reflow soldering footprint VFPGA64	247
9.24.144	RSSI_TIMER_FIRST_PERIOD (02DCh)	212	15	Reflow soldering footprint HVQFN40	251
9.24.145	RSSI_CTRL_00_AB (02DEh)	212	16	Surface mount reflow soldering	255
9.24.146	RSSI_NB_ENTRIES_AB (02DFh)	213	17	Handling information	256
9.24.147	RSSI_THRESHOLD_PHASE_TABLE (02E0h)	213	18	Appendix: EEPROM LOAD_RF_ CONFIGURATION FW2.0	257
9.24.148	TX_PARAM_ENTRY_TABLE (03A2h)	214	19	Appendix: EEPROM LOAD_RF_ CONFIGURATION FW2.1	275
9.24.149	LPCD_AVG_SAMPLES (0492h)	217	20	Abbreviations	293
9.24.150	LPCD_RSSI_TARGET (0494h)	218	21	References	294
9.24.151	LPCD_RSSI_HYST (0496h)	218	22	Revision history	295
9.24.152	LPCD_CONFIG (0497h)	218	23	Legal information	296
9.24.153	LPCD_THRESHOLD_COARSE (049Ah)	219			
9.24.154	LPCD_VDDPA (04B5h)	220			
9.24.155	ULPCD_VDDPA_CTRL (04BFh)	221			
9.24.156	ULPCD_TIMING_CTRL (04C2h)	222			
9.24.157	ULPCD_VOLTAGE_CTRL (04C6h)	222			
9.24.158	ULPCD_RSSI_GUARD_TIME (04C9h)	222			
9.24.159	ULPCD_RSSI_SAMPLE_CFG (04CAh)	222			
9.24.160	ULPCD_THRESH_LVL(04CBh)	223			
9.24.161	ULPCD_GPIO3 (04CCh)	223			
9.24.162	TXIRQ_GuardTime (0559h)	223			
9.24.163	FDT_default_val (055Dh)	223			
9.24.164	RXIRQ_GuardTime (0561h)	223			
9.24.165	NFCLD_RFLD_Valid (006D3h)	224			
9.24.166	CurrentSensorTrimConfig (0ABCh)	224			
9.24.167	CORRECTION_ENTRY_TABLE (0BDAh)	224			
9.24.168	RTRANS_FTRANS_TABLE (0C03h)	226			
9.24.169	CFG_NOV_CAL (0C83h)	227			
9.24.170	NOV_CAL_VAL1 (0C84h)	227			
9.24.171	NOV_CAL_VAL2 (0C85h)	227			
9.24.172	NOV_CAL_THRESHOLD (0C86h)	228			
9.24.173	NOV_CAL_OFFSET1 (0C87h)	228			
9.24.174	NOV_CAL_OFFSET2 (0C8Bh)	228			
9.24.175	VDDPA_DISCHARGE (0C8Fh)	228			
9.24.176	ARC_RM_A106_FDT (0C9Dh)	228			
9.24.177	Tx_Symbol23_Mod_Reg_BR_53 (0CC5h)	230			
9.24.178	Tx_Data_Mod_Reg_BR_53 (0CC9h)	230			
9.24.179	Tx_Symbol23_Mod_Reg_BR_106 (0CCDh)	230			
9.24.180	Tx_Data_Mod_Reg_BR_106 (0CD1h)	230			
9.24.181	Tx_Symbol23_Mod_Reg_BR_212 (0CD5h)	230			
9.24.182	Tx_Data_Mod_Reg_BR_212 (0CD9h)	230			
10	Limiting values	231			

Please be aware that important notices concerning this document and the product(s) described herein, have been included in section 'Legal information'.

© NXP B.V. 2021.

All rights reserved.

For more information, please visit: <http://www.nxp.com>

For sales office addresses, please send an email to: salesaddresses@nxp.com

Date of release: 21 April 2021

Document identifier: PN5190B1

Document number: 662230