

Standard PM Step Motors

PM42L-048-HHC9

Model Specifications

Model:	PM42L-048-HHC9
Shaft Length:	12mm
Wire Length:	300mm fly lead (no connector)
Wire Holder:	90 deg. Left
Front Plate:	FPH
Electrical:	24V, 600mA
	Bipolar Constant Current
	7 ohms, MS70M

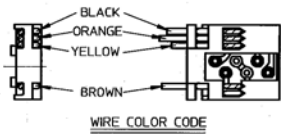

WIRE COLOR	MOTOR
BLACK	A1
BROWN	A3
ORANGE	B1
YELLOW	B3

COLOR	BLACK	ORANGE	BROWN	YELLOW
STEP 1	-	+	+	-
STEP 2	-	-	+	+
STEP 3	+	-	-	+
STEP 4	+	+	-	-

SWITCHING SEQUENCE
(VIEWED FROM MOUNTING SURFACE)

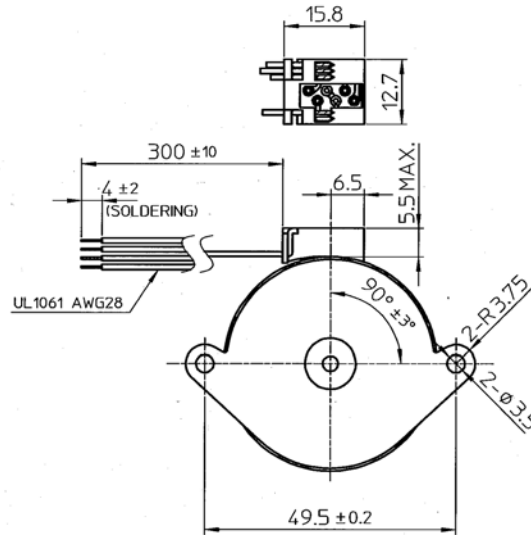

MARKING

NMB-MAT PM42L-048-HHC9
JAPAN H9817
<JAPAN>

NMB-MAT PM42L-048-HHC9
THAILAND TA9817
<THAILAND>

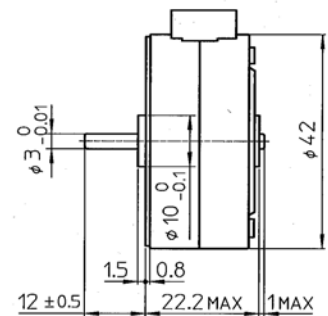

Standard PM Step Motors

PM42L-048-HHC9

DYNAMIC TORQUE CHARACTERISTICS (No. 62796) (ALL VALUES ARE GAINED BY MEASUREMENT AND NOT SPECIFICATIONS VALUES)

Model : PM42L-048-HHC9
 Drive Mode : BIPOLAR CHOPPER
 Drive Voltage : 24.0 V
 Method : 2-2P
 Drive IC : UDN2917EB
 Surge/Current : / 600 mA / Phase (Peak)
 Coil Resistance : 7.0 Ω
 Magnet Material : MS70M
 Stator Material : SECC

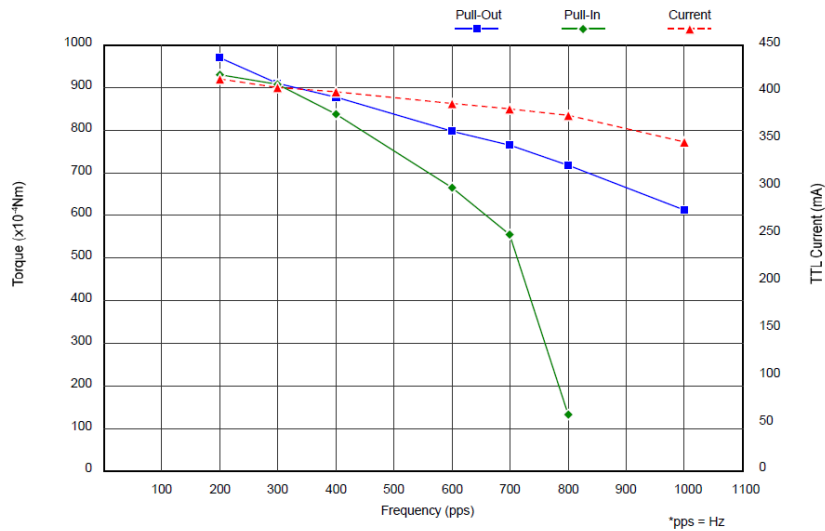

(TTL Current = Over all current drawn by the driver)

Frequency (pps)	200	300	400	600	700	800	1000
■ Pull-Out (x10 ⁻⁴ Nm)	968.0	909.1	875.8	796.3	764.0	716.9	611.0
◆ Pull-In (x10 ⁻⁴ Nm)	928.7	906.2	837.5	663.9	553.1	131.4	
▲ Current (mA)	414	405	400	388	382	375	347

Minebea Motor Manufacturing Corporation