

PM1200HCE330-1

HIGH POWER SWITCHING USE
INSULATED TYPE

HVIPM (High Voltage Intelligent Power Module)

PM1200HCE330-1



- Ic 1200A
- VCES 3300V
- Insulated Type
- 1-element in a Pack
- AISiC Baseplate
- Monolithic Gate Drive
- Protection Logic : OC/OT/UV
(Over Current / Over Temperature / Under supply Voltage)

APPLICATION

Traction drives, High Reliability Converters / Inverters, DC choppers

OUTLINE DRAWING

Dimensions in mm

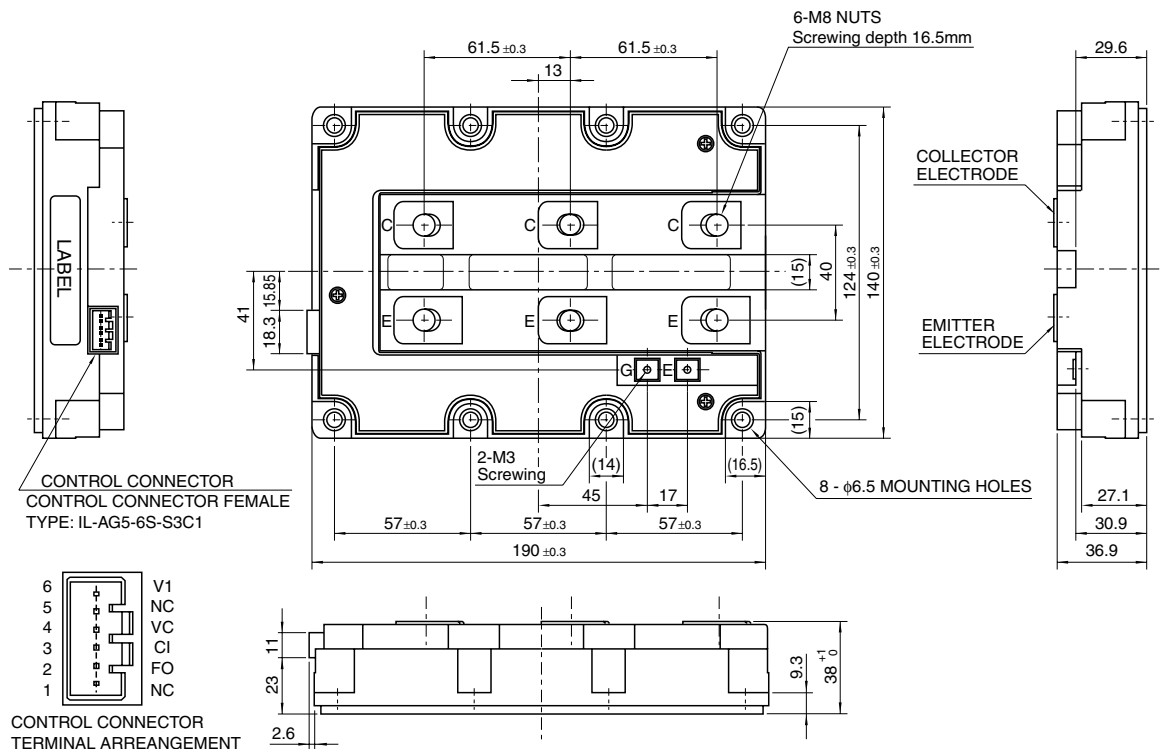

HVIPM (High Voltage Intelligent Power Module)

PM1200HCE330-1

HIGH POWER SWITCHING USE
INSULATED TYPE

HVIPM (High Voltage Intelligent Power Module)

INTERNAL FUNCTIONS BLOCK DIAGRAM

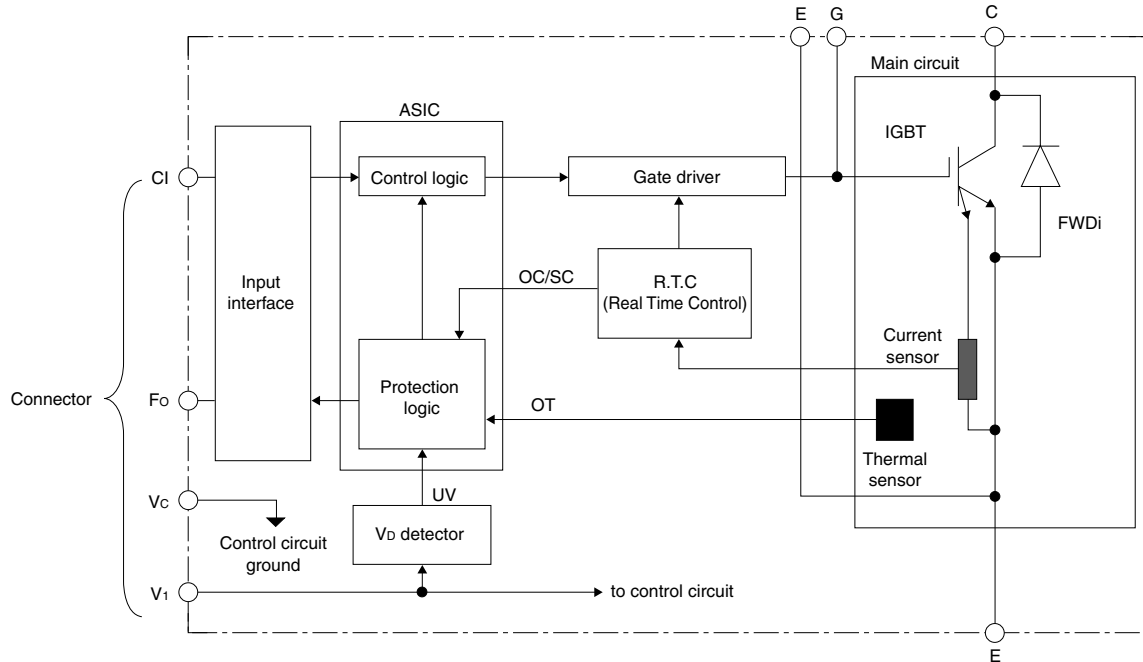

MAXIMUM RATINGS

INVERTER PART

Symbol	Item	Conditions	Ratings	Unit
V _{CES}	Collector-emitter voltage	T _j = 25°C	3300	V
±I _C	Collector current	T _C = 25°C	1200	A
±I _{CP}	Collector current (peak)	T _C = 25°C	2400	A
P _C	Maximum power dissipation	T _C = 25°C, IGBT part	12500	W
V _{iso}	Isolation voltage	RMS, sinusoidal, f = 60Hz, t = 1min.	6000	V
T _j	Junction temperature		-40 ~ +150	°C
T _{stg}	Storage temperature		-40 ~ +115	°C

CONTROL PART

Symbol	Item	Conditions	Ratings	Unit
V _D	Control supply voltage	Applied between : V ₁ -V _C	26.4	V
V _{CIN}	Input voltage	Applied between : C ₁ -V _C	26.4	V
V _{F0}	Fault output supply voltage	Applied between : F ₀ -V _C	26.4	V
I _{F0}	Fault output current	Sink current of F ₀ terminal	20.0	mA

HVIPM (High Voltage Intelligent Power Module)

Jul. 2005

PM1200HCE330-1

**HIGH POWER SWITCHING USE
INSULATED TYPE**

HVIPM (High Voltage Intelligent Power Module)

ELECTRICAL CHARACTERISTICS

INVERTER PART

Symbol	Item	Conditions	Limits			Unit
			Min	Typ	Max	
ICES	Collector cutoff current	$V_{CE} = V_{CES}, T_j = 25^\circ\text{C}$	—	—	15	mA
VCE(sat)	Collector-emitter saturation voltage	$I_C = 1200\text{A}, V_D = 24\text{V}, V_{CIN} = 0\text{V}$ $T_j = 25^\circ\text{C}$, at the main terminals	—	3.05	3.95	V
		$I_C = 1200\text{A}, V_D = 24\text{V}, V_{CIN} = 0\text{V}$ $T_j = 125^\circ\text{C}$, at the main terminals	—	3.40	—	
VEC	Emitter-collector voltage	$-I_C = 1200\text{A}, V_D = 24\text{V}, V_{CIN} = 24\text{V}$ $T_j = 25^\circ\text{C}$, at the main terminals	—	2.90	3.75	V
		$-I_C = 1200\text{A}, V_D = 24\text{V}, V_{CIN} = 24\text{V}$ $T_j = 125^\circ\text{C}$, at the main terminals	—	2.80	—	
ton	Turn-on time		—	—	6.00	μs
Eon	Turn-on switching energy	$V_{CC} = 1500\text{V}, I_C = 1200\text{A}$	—	1.80	—	J/pulse
toff	Turn-off time	$V_D = 24\text{V}, V_{CIN} = 0\text{V} \leftrightarrow 24\text{V}$	—	—	6.00	μs
Eoff	Turn-off switching energy	$T_j = 125^\circ\text{C}, L_s = 100\text{nH}$	—	1.60	—	J/pulse
trr	Reverse recovery time	Inductive load	—	—	1.40	μs
Erec	Reverse recovery energy		—	0.95	—	J/pulse

CONTROL PART

Symbol	Item	Conditions	Limits			Unit
			Min	Typ	Max	
VD	Control supply voltage	Applied between : V_1-V_C	21.6	24.0	26.4	V
ID	Circuit current	$V_D = 24\text{V}, T_j = 25^\circ\text{C}$	—	80	120	mA
Vth(ON)	Input ON threshold voltage	Applied between : C_1-V_C	6.1	6.7	7.3	V
Vth(OFF)	Input OFF threshold voltage		10.5	11.1	11.7	V
tFO	Fault output pulse width	$V_D = 24\text{V}$	—	100	200	μs
OC	Over current trip level	$T_j = -25^\circ\text{C} \sim 125^\circ\text{C}$	2200	—	—	A
OT	Over temperature protection	Baseplate temperature detection	103	113	123	°C
Otr			88	98	108	°C
UV	Supply circuit under	$T_j = -25^\circ\text{C} \sim 125^\circ\text{C}$	19.2	20.0	20.8	V
Uvr	voltage protection		—	20.5	—	V

HVIPM (High Voltage Intelligent Power Module)

PM1200HCE330-1

**HIGH POWER SWITCHING USE
INSULATED TYPE**

HVIPM (High Voltage Intelligent Power Module)

THERMAL CHARACTERISTICS

Symbol	Item	Conditions	Limits			Unit
			Min	Typ	Max	
R _{th(j-c)Q}	Thermal resistance	Junction to Case, IGBT part	—	—	10.0	K/kW
R _{th(j-c)R}		Junction to Case, FWDi part	—	—	20.0	K/kW
R _{th(c-f)}	Contact thermal resistance	Case to Fin, λ _{grease} = 1W/m·K	—	7.5	—	K/kW

MECHANICAL CHARACTERISTICS

Symbol	Item	Conditions	Limits			Unit
			Min	Typ	Max	
M	Mounting torque	M8 : Main terminals screw	7.0	—	13.0	N·m
		M6 : Mounting screw	3.0	—	6.0	
		M3 : Auxiliary terminals screw	0.4	—	0.6	
—	Mass		—	1.5	—	kg
CTI	Comparative tracking index		600	—	—	—
d _a	Clearance distance in air		19.5	—	—	mm
d _s	Creepage distance along surface		32.0	—	—	mm

RECOMMENDED CONDITIONS FOR USE

Symbol	Item	Conditions	Recommended values			Unit
			Min	Typ	Max	
V _{CC}	DC link voltage	Applied between : C–E terminals	—	1500	2200	V
V _D	Control supply voltage	Applied between : V ₁ –V _c	22.8	24.0	25.2	V
V _{CIN(ON)}	Input ON voltage	Applied between : C ₁ –V _c	—	—	4.0	V
V _{CIN(OFF)}	Input OFF voltage		16.0	—	—	V
f _{PWM}	PWM input frequency	3 sinusoidal PWM control	—	0.5	2.0	kHz
t _{dead}	Dead time	Reference at IPM's input signals	8.0	—	—	μs

HVIPM (High Voltage Intelligent Power Module)

PM1200HCE330-1

HIGH POWER SWITCHING USE
INSULATED TYPE

HVIPM (High Voltage Intelligent Power Module)

PERFORMANCE CURVES

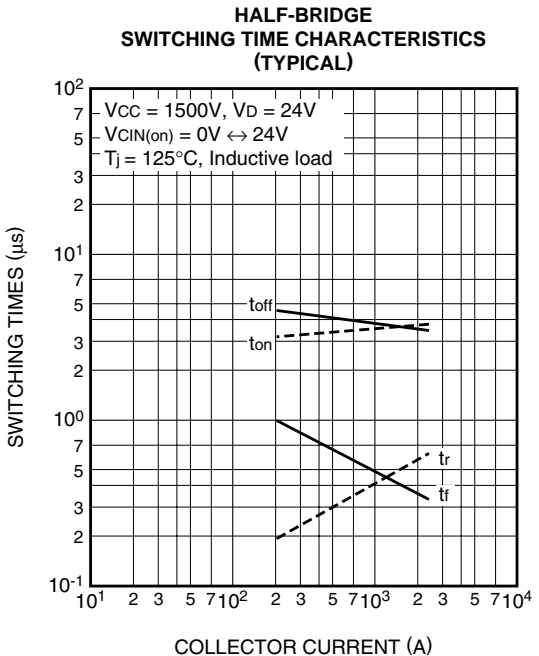
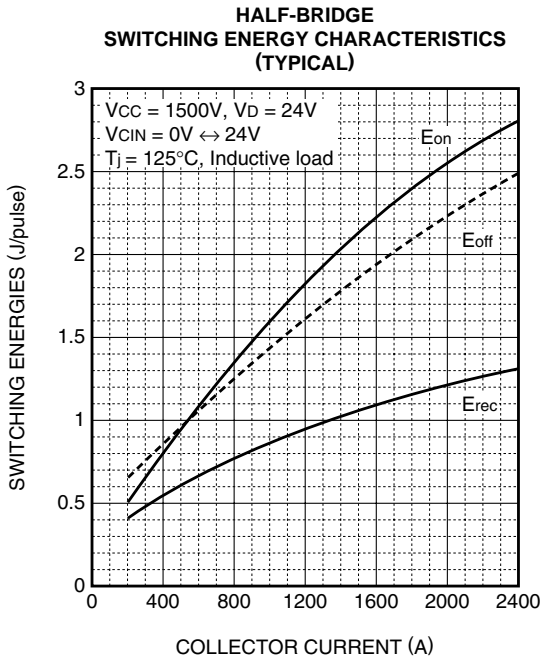
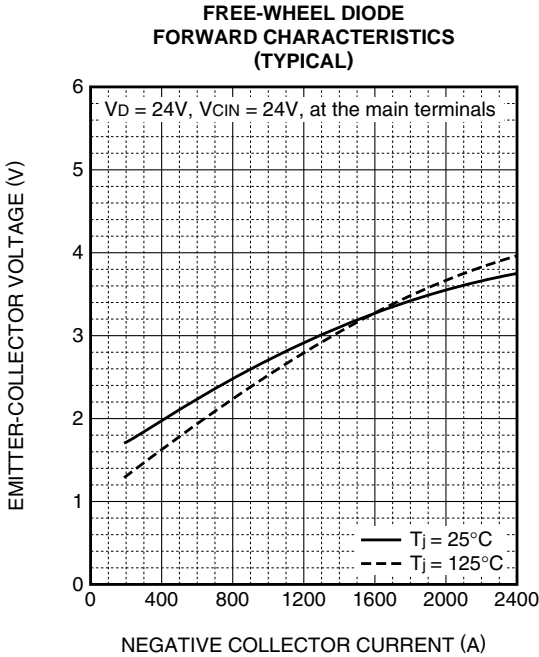
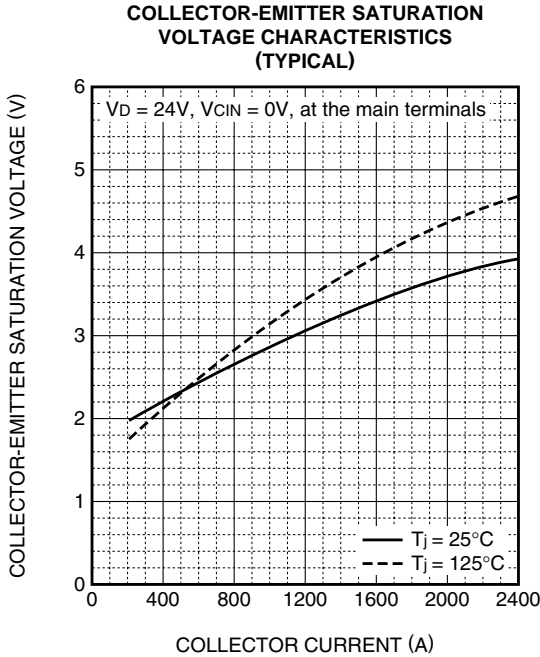

HVIPM (High Voltage Intelligent Power Module)

Jul. 2005



PM1200HCE330-1

HIGH POWER SWITCHING USE
INSULATED TYPE

HVIPM (High Voltage Intelligent Power Module)

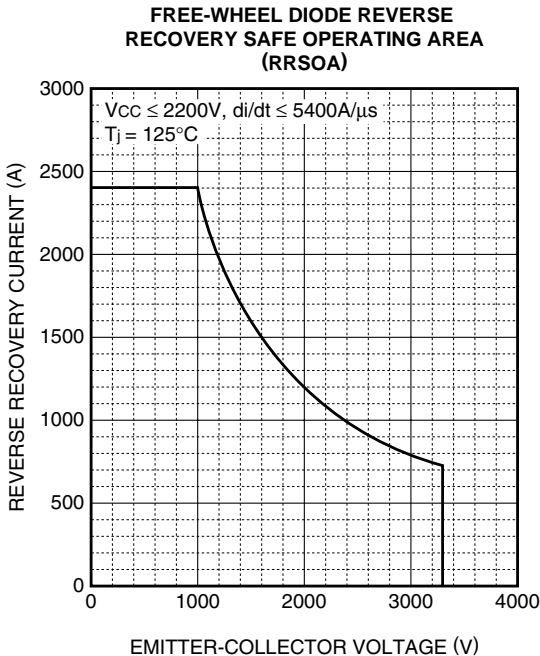
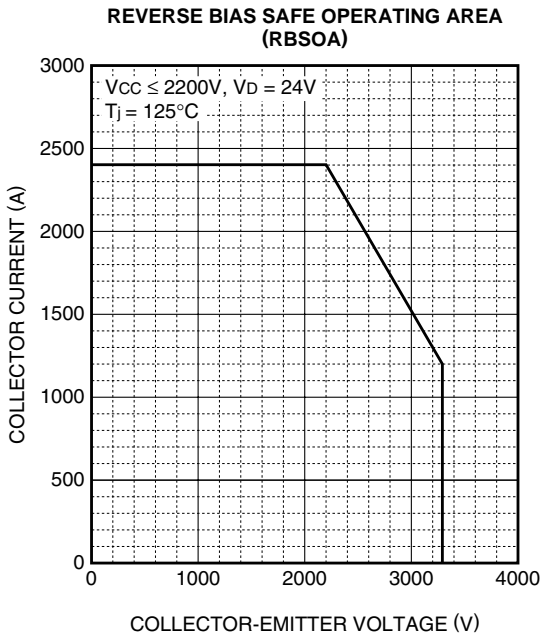
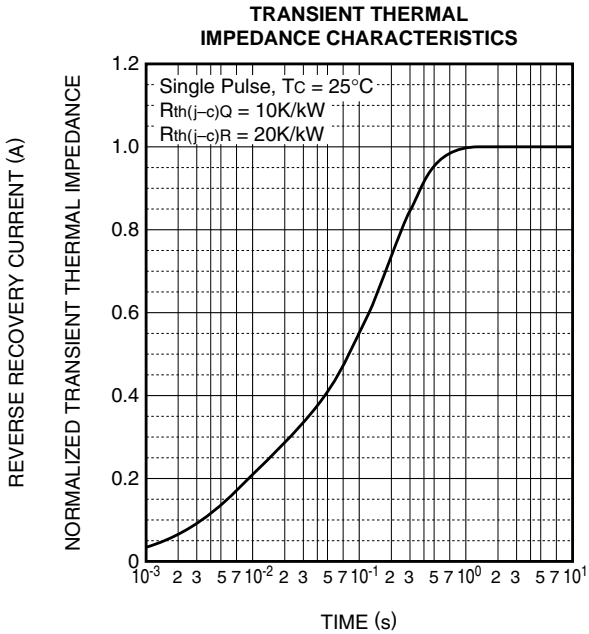
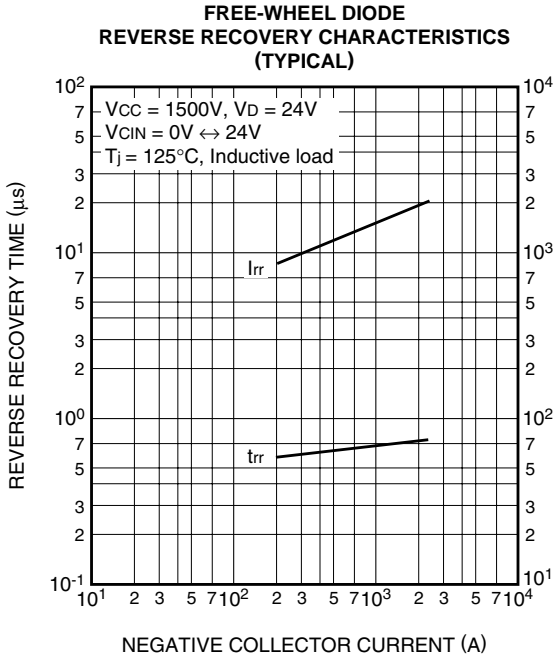

HVIPM (High Voltage Intelligent Power Module)

Jul. 2005

