



The technical data and specifications of the products shown in this catalogue are for reference only, and apply to products available at the time of catalogue printing in November 2018. Product modification often involves changes to technical data and size, and it is therefore recommended that the buyer request the latest technical data and specifications before placing a purchasing contract.

Future updates to this printed catalogue can be found at
<https://www.yamaichi.de/downloads/product-catalogues.html>

Technische Daten und Maßangaben der im Katalog aufgeführten Produkte beziehen sich auf Referenzprodukte aus dem Produktsortiment bei Erscheinen des Katalogs im November 2018. Produktänderungen, insbesondere aufgrund technischer Weiterentwicklung, bedingen regelmäßig veränderte technische Daten und Maße. Dem Besteller wird daher dringend empfohlen, vor Vertragsabschluss technische Daten und Maßangaben gesondert nachzufragen.

Zukünftige Updates dieses gedruckten Katalogs finden Sie auf
<https://www.yamaichi.de/de/downloads/produktkataloge.html>

CARD CONNECTORS

COMPATIBLE FLASH MEMORY CARDS

SERIES FPS, FMS, FUS, PJS, CF.....5

SD AND MMC

SERIES FPS.....6 - 25

MICROSD

SERIES PJS.....26 - 32

SIM

SERIES FMS.....33 - 40

MICROSIM AND NANOSIM

SERIES FUS.....41 - 42

COMPACT FLASH

SERIES CF.....43 - 51

EUROPEAN DISTRIBUTORS

52

PART NUMBER INDEX

53

YAMAICHI ELECTRONICS FACTS & FIGURES

Foundation:	Headquarters, Tokyo: 1956 European Headquarter, Aschheim near Munich: 1986
Turnover:	Worldwide 230 m € p.a., Europe 75 m € p.a.
Employees:	Over 2,100, in Europe 285
Certification:	DIN EN ISO 9001:2015 (HQ and production EU) ISO 14001:2015 (production in Frankfurt/Oder) ISO/TS 16949 (selected production sites)
Locations:	Worldwide 7 production sites, 6 design centers, 13 sales locations

as of May 2018

YAMAICHI ELECTRONICS ZAHLEN & FAKTEN

Firmengründung:	Konzernsitz, Tokyo: 1956 Europäische Zentrale, Aschheim bei München: 1986
Umsatz:	weltweit 230 Mio € p.a., Europa 75 Mio € p.a.
Mitarbeiter:	über 2.100 weltweit, 285 in Europa
Zertifizierung:	DIN EN ISO 9001:2015 (HQ und Produktion EU) ISO 14001:2015 (Produktion in Frankfurt/Oder) ISO/TS 16949 (ausgewählte Produktionsstandorte)
Standorte:	weltweit 7 Produktionsstandorte, 6 Design-Zentren, 13 Vertriebszentren

Mai 2018

PRODUCT RANGE

Yamaichi Electronics designs, manufactures and markets high performance interconnection devices, also for use in the most demanding applications of electronic systems: with high temperature environments, protected interconnections for harsh environments and high-speed interconnections for data networking applications. The portfolio covers high precision fine pitch IC sockets, connectors, cable assemblies and flexible printed circuits.

YAMAICHI EUROPE

Yamaichi Electronics Deutschland GmbH, located in Aschheim near Munich, is your European partner for connectivity solutions covering Industrial, Automotive, Measurement & Testing, Data Networking, Medical and Embedded & Semiconductor applications.

Two Divisions:

Connector Solutions: Portfolio: Connectors for Industrial use, for example circular connectors Y-Circ M (M12) and Y-Circ P (Push-Pull), Y-Con Series (RJ45 and USB). Automotive connectors FAKRA/HSD, Quadlock (Y-QUAD) and others, card connectors, high speed connector systems and latest input /output connectors. Internal connectors for high end applications (Y-Lock series). Data networking connectors, cables and cable assemblies as well as production sockets.

Test Solutions: Portfolio: IC semiconductor test & burn-in sockets, modular test contactors, test adapter systems for computer-on-modules, receptacles, spring probe pins, PCB design.

In all product areas we offer customer specific solutions.

ENGINEERING

Two design centers in Munich (Germany) and Sousse (Tunisia) react quickly to market challenges and work with the most modern technologies for the realisation of customer needs from product ideas to qualified mass production. Two fully equipped inhouse test laboratories allow internal product qualification and guarantee convincing product quality.

PRODUCTION FOR THE EUROPEAN MARKET

In our production facility in Frankfurt (Oder) we have been manufacturing connectors and complex cable assemblies for e.g. industrial or medical applications since 2006. In the area of test solutions we produce high end test contactors, module test adapters and receptacles. We offer special know-how in overmolding, welding, resistance welding and machining technologies. To ensure highest quality and short delivery times we have a high grade of vertical range of manufacturing and established a reliable European supplier network.

LEISTUNGSSPEKTRUM

Yamaichi Electronics entwickelt, produziert und vermarktet hochleistungsfähige elektromechanische Komponenten, auch für anspruchsvollste Anwendungen in elektronischen Systemen: für den Hochtemperaturbereich, geschützt für den Einsatz unter rauen Umgebungsbedingungen und High Speed Verbindungstechnik für Daten networking Anwendungen. Das Portfolio umfasst hochpräzise Fine pitch IC Sockel, Steckverbinder, Kabelassemblierungen und flexible Leiterplatten.

YAMAICHI EUROPA

Yamaichi Electronics Deutschland GmbH, mit Sitz in Aschheim bei München, ist Ihr europäischer Ansprechpartner für Verbindungstechnik. Lösungen für Applikationen in: Automatisierung, Automotive, Mess- und Prüftechnik, Data Networking, Medizintechnik und Halbleiterindustrie.

Zwei Bereiche:

Connector Solutions: Portfolio: Industriesteckverbinder, z.B. Rundsteckverbinder Y-Circ M (M12) und Y-Circ P (Push-Pull), Y-Con (RJ45 und USB). Automotive Steckverbinder FAKRA/HSD, Quadlock (Y-QUAD) und andere spezielle Automotive Lösungen, Kartensteckverbinder, High Speed Steckverbindersysteme und neueste Input/Output Steckverbinder. Interne Steckverbinder für High End Applikationen (Y-Lock Serie). Data Networking Steckverbinder, Kabel und Kabelassemblierungen, Produktionssockel.

Test Solutions: Portfolio: IC Halbleiter Test & Burn-In Sockel, modulare Test Contactoren, Test Adapter Systeme für Computer-on-Modules, Receptacles, Federkontaktstifte, PCB Design.

In allen Produktbereichen bieten wir kundenspezifische Lösungen an.

ENGINEERING

Mit zwei Design-Zentren in München und Sousse (Tunesien) ist die schnelle Reaktion auf Marktanforderungen und Kundenwünsche sichergestellt. Unser Entwicklungsteam arbeitet mit den modernsten Technologien zur Realisierung von Kundenanforderungen. Umfangreich ausgestattete hauseigene Testlabore ermöglichen die interne Qualifizierung von Produkten und gewährleisten überzeugende Produktqualität.

PRODUKTION FÜR DEN EUROPÄISCHEN MARKT

An unserem Fertigungstandort in Frankfurt (Oder) werden seit 2006 Steckverbinder und komplexe Kabelassemblierungen z.B. für Industrie- oder Medizinanwendungen hergestellt. Im Bereich Test Solutions werden High End Test Contactors, Modultestadapter und Receptacles gefertigt. Wir bieten Spezial-Know How in den Fertigungstechnologien Spritzguss, Schweißen, Widerstandsschweißen und Zerspanungstechnik. Die hohe Fertigungstiefe sowie in Europa ansässige zuverlässige Zulieferfirmen garantieren hochwertige Produkte und kurze Lieferzeiten.



SECURE DIGITAL & MMC

FPS009



SIM

FMS



MICROSIM

FUS



NANOSIM

FUS

FEATURES

Yamaichi Series

Series Page Number

26 - 33

26 - 33

44 - 45

44 - 45

Read/Write [MB/s]

2.5 / 2.5

-

-

-

Write Protect

no

-

-

-

Voltage

2.7 ~ 3.6

-

-

-

Op. Temp. Range

-25 ~ +85°C

-25 ~ +85°C

-25 ~ +85°C

-25 ~ +85°C

of Pads

9 (SD) 7 (MMC)

8

8

8

Weight (g)

1.5

-

-

-

Volume (mm³)

1,075

(281)

(281)

(281)

Dimensions

24 x 32 x 2.1

15 x 25 x 0.76

12 x 15 x 0.76

1?? x 25 x 0.76

Association

www.sdcard.org/www.mmca.org

www.etsi.org

www.etsi.org

www.etsi.org



MICROSD

PJS008



CFAST (CF)

CF050

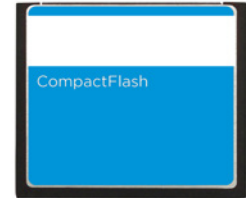

COMPACT FLASH (CF)

CF050

FEATURES

Yamaichi Series

Series Page Number

26 - 33

47 - 55

47 - 55

Read/Write [MB/s]

12.5 / 12.5

up to 600

20 / 20

Write Protect

yes

no

no

Voltage

2.7 ~ 3.6

3.3 / 5.0

3.3 / 5.0

Op. Temp. Range

-25 ~ +85°C

-40 ~ +85°C

0 ~ +70°C

of Pads

8

24

50

Weight (g)

0.4

~ 10

Typ.I: 11.4 / Typ.II: 13.5

Volume (mm³)

165

5141

Typ.I: 5,141 / Typ.II: 7,790

Dimensions

11 x 15 x 1.0

42.8 x 36.4 x 3.6

42.8 x 36.4 x 3.3/ (Typ.II 5.0)

Association

www.sdcard.org

www.compactflash.org

www.compactflash.org

SPECIFICATIONS

Insulation Resistance:	1,000MΩ min. at 500V DC
Withstanding Voltage:	500V ACrms for 1 minute
Contact Resistance:	100mΩ at 1mA / 40mV max.
Voltage Rating:	5V DC
Current Rating:	0.5A
Operating Temp. Range:	-25°C to +85°C
Coplanarity:	≤ 0.1mm
Mating Cycles:	10,000 (office environment)

MATERIALS AND FINISH

Insulator:	LCP
Shielding Plate:	Stainless Steel,
Contacts:	Copper Alloy
Contact Area:	Ni-Au
Solder Tail:	Ni-Sn



PART NUMBER

FPS 009 - 290* - 0

Series No.			
Number of Contacts			
Design No. *	1 = one sides break, Tin plating on cover 4 = one sides break, Ni plating on cover with Au on solder terminal of cover 5 = single side break, Ni plating on cover with Au on solder terminal of cover		
0 = Tape & Reel Packaging			

FEATURES

- Connector for both card types (MMC and SD card)
- Smooth extraction function by Push-in/ Push-out of card
- Soft lock mechanism for SD card
- Super low profile (Ht. 2.80 x W. 28.10 x L. 27.10)
- Tape & Reel packaging (500 pcs / reel)
- Card detector
- Write protection switch
- Mechanism to avoid flying out of the card
- Closed cover
- RoHS2011/65/EU

OUTLINE DIMENSIONS

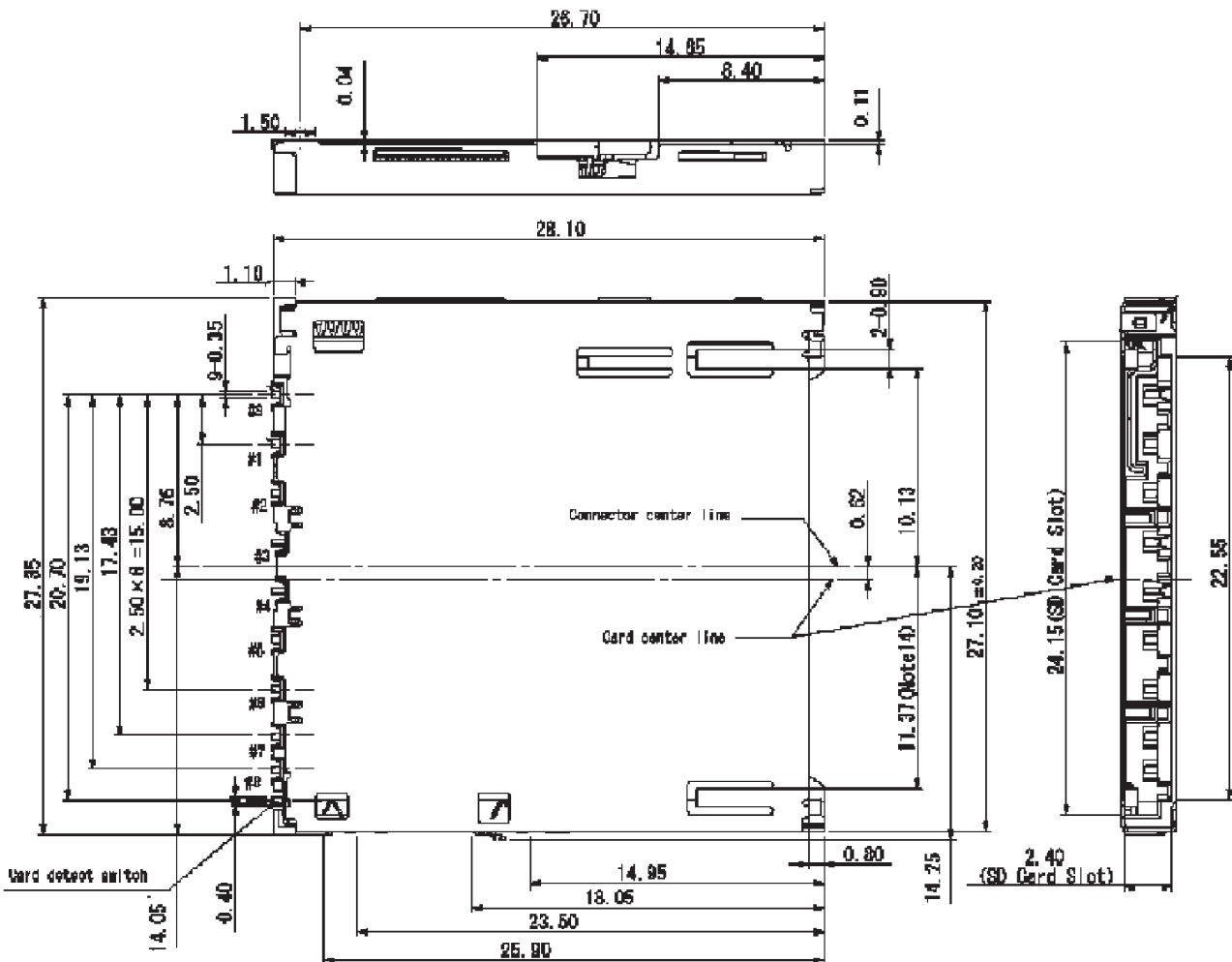

RECOMMENDED PCB LAYOUT FOR FP5009-2901-0

Top View

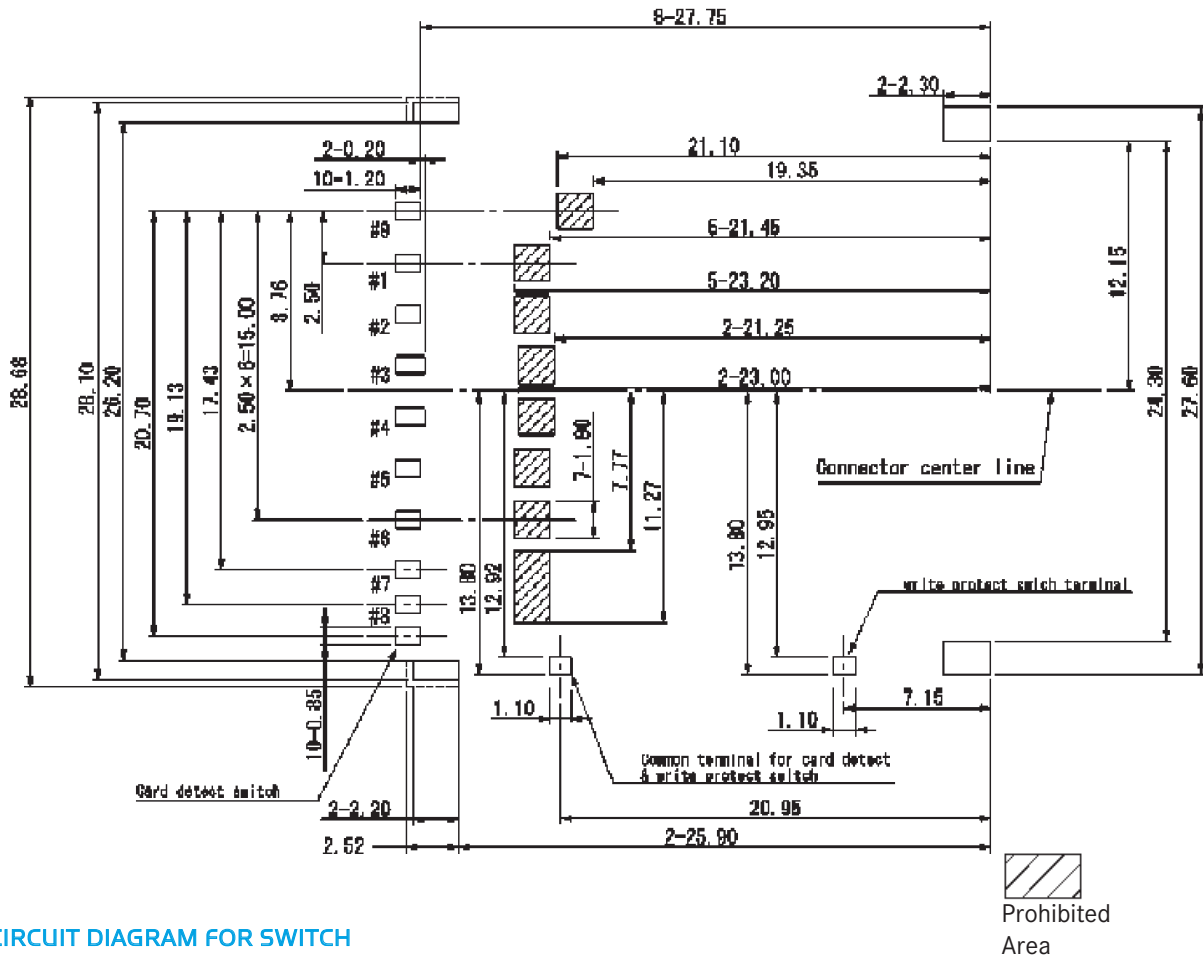

CIRCUIT DIAGRAM FOR SWITCH

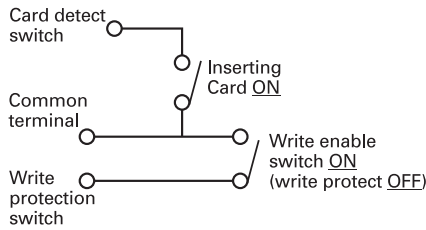

CARD INSERTION DETAILS

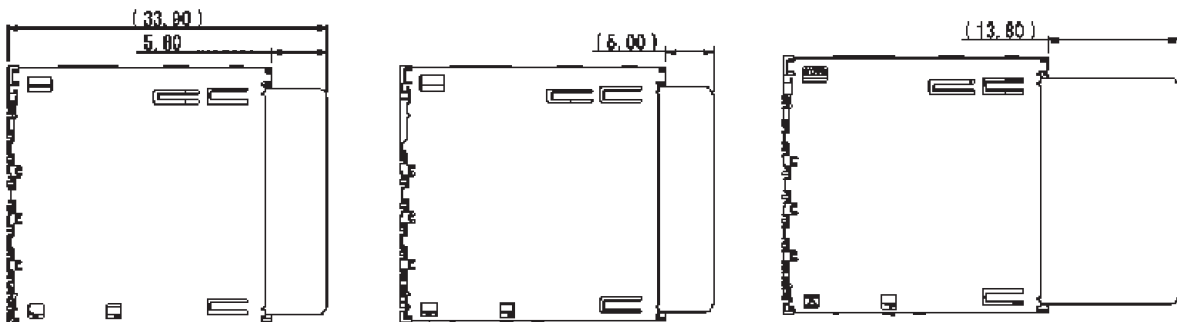

Card locked position

Card pushed position

Card eject position

SPECIFICATIONS

Insulation Resistance:	1,000MΩ min. at 500V DC
Withstanding Voltage:	500V ACrms for 1 minute
Contact Resistance:	100mΩ at 1mA / 20mV max.
Voltage Rating:	5V DC
Current Rating:	0.5A
Operating Temp. Range:	-25°C to +85°C
Mating Cycles:	5,000 (harsh environment) 10,000 (office environment)

PART NUMBER

FPS 009 - 2903 - 0 - VE

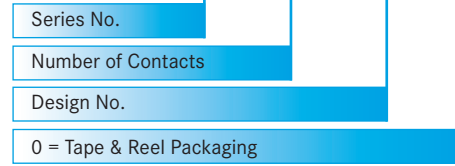

MATERIALS AND FINISH

Insulator:	LCP
Shielding plate:	Stainless
Contact:	Copper Alloy
	Contact area: Ni-Au
	Solder tail: Ni-Sn

AUTOMOTIVE COMPLIANT



FEATURES

- SD reader for harsh environment with automotive applications
- Connector for both card types (MMC and SD card)
- Smooth extraction function by Push-in/ Push-out of card
- Tape & Reel packaging (500 pcs / reel)
- EMI prevention with four grounding terminals
- Card detector
- Write protection switch
- RoHS2011/65/EU

OUTLINE DIMENSIONS

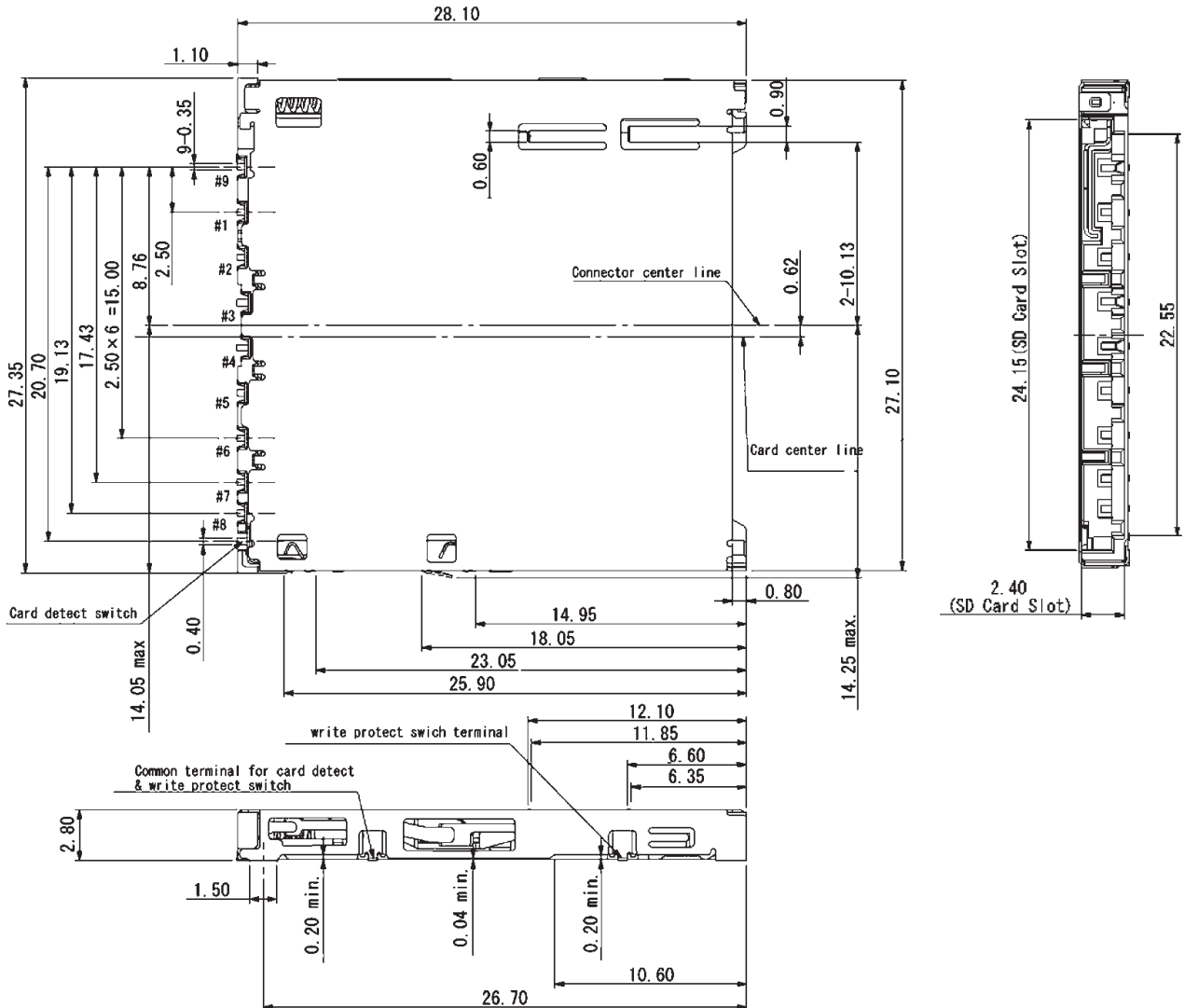

RECOMMENDED PCB LAYOUT FOR FP5009-2903-OVE

Top View

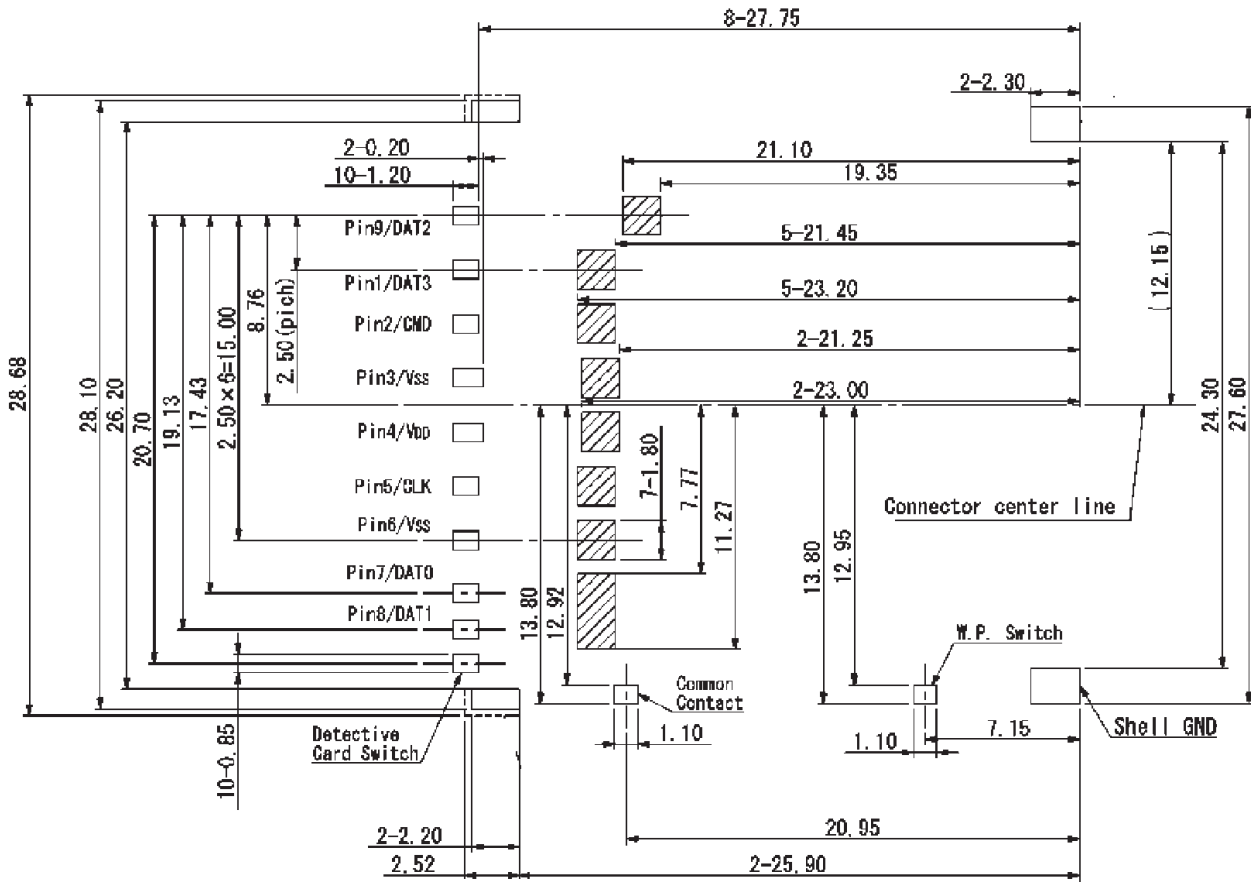

CIRCUIT DIAGRAM FOR SWITCH

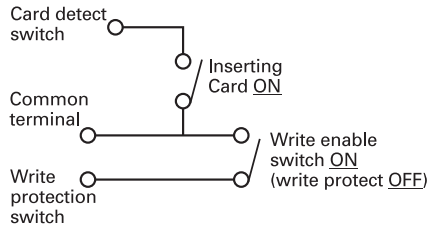

CARD INSERTION DETAILS

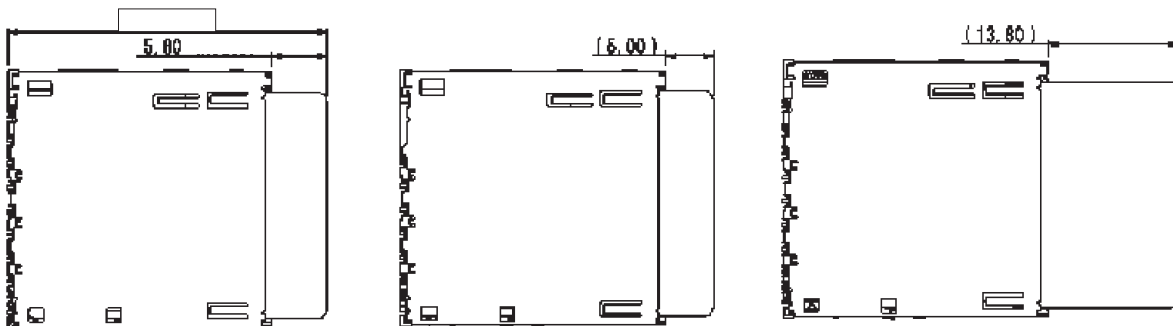

Card locked position

Card pushed position

Card eject position

SPECIFICATIONS

Insulation Resistance:	1,000MΩ min. at 500V DC
Withstanding Voltage:	500V ACrms for 1 minute
Contact Resistance:	100mΩ at 1mA / 20mV max.
Voltage Rating:	250Vrms AC
Current Rating:	0.5A
Operating Temp. Range:	-25°C to +85°C
Coplanarity:	≤ 0.1mm
Mating Cycles:	10,000 (office environment)

MATERIALS AND FINISH

Insulator:	LCP
Shielding Plate:	SUS
Contacts:	Copper Alloy
Contact Area:	Ni-Au
Solder Tail:	Ni-Sn

FEATURES

- Connector for both card types (MMC and SD card)
- Card detector
- Smooth extraction function by Push-in/ Push-out of card
- Soft lock mechanism for SD card
- Two-point contact, protection against electrical interruption
- Write protection switch
- Mechanism to avoid flying out of the card
- RoHS2011/65/EU
- Tape & Reel packaging (600 pcs / reel)

PART NUMBER

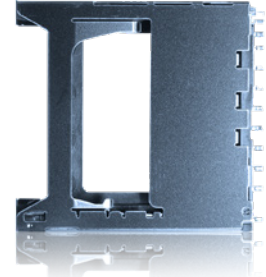
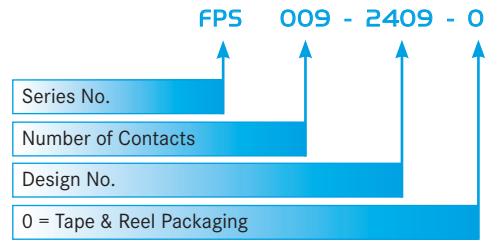

AUTOMOTIVE COMPLIANT

OUTLINE DIMENSIONS

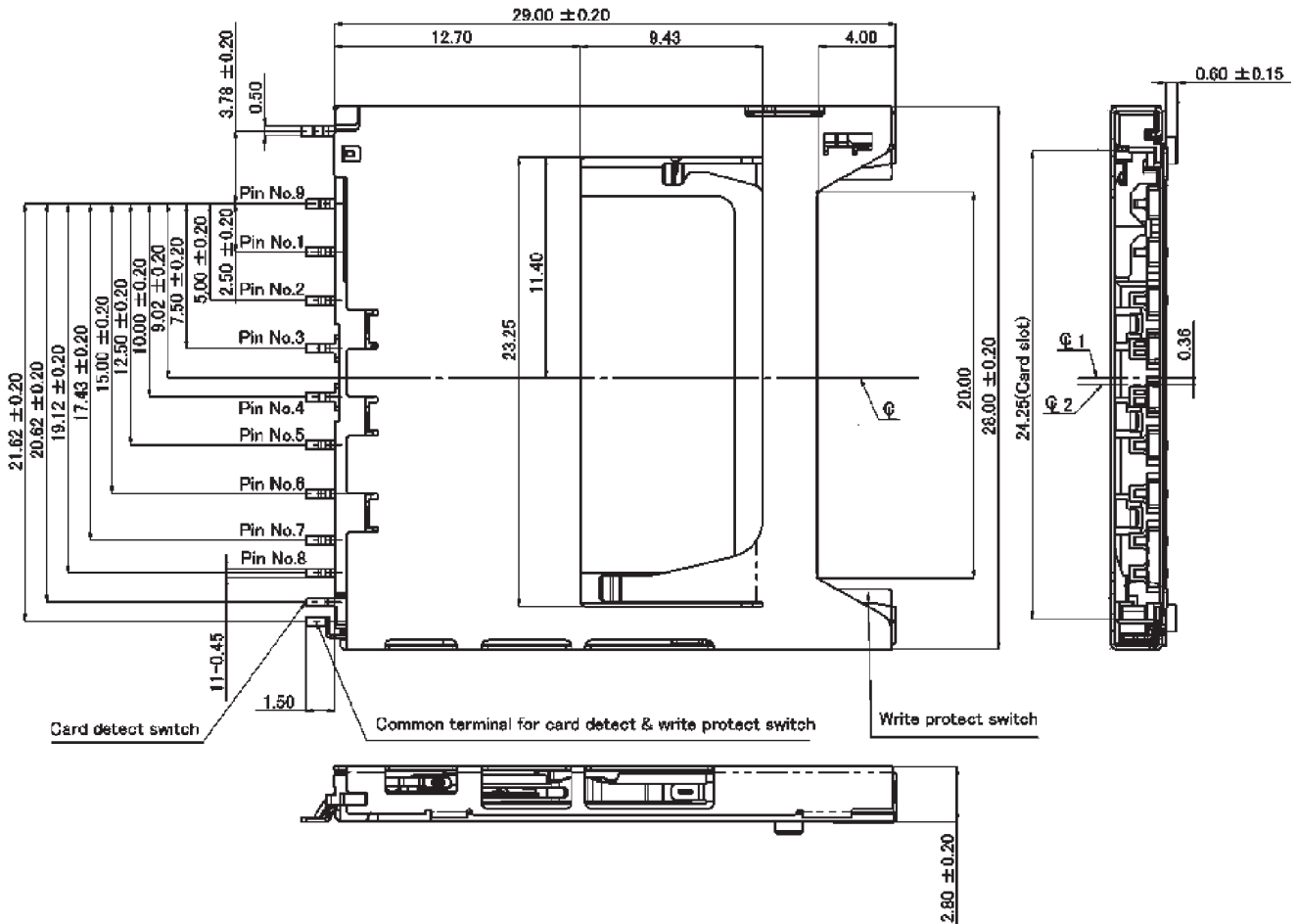

SPECIFICATIONS

Insulation Resistance:	1,000MΩ min. at 500V DC
Withstanding Voltage:	500V ACrms for 1 minute
Contact Resistance:	100mΩ at 1mA / 20mV max.
Voltage Rating:	250Vrms AC
Current Rating:	0.5A
Operating Temp. Range:	-25°C to +85°C
Coplanarity:	≤ 0.1mm
Mating Cycles:	10,000 (office environment)

MATERIALS AND FINISH

Insulator:	LCP
Shielding Plate:	SUS, t = 0.2
Contacts:	Copper Alloy: t = 0.15
Contact	Area: Ni-Au
Solder Tail:	Ni-SnCu

FEATURES

- Connector for both card types (MMC and SD card)
- Smooth extraction function by Push-in/ Push-out of card
- Soft lock mechanism for SD card
- Tape & Reel packaging (500 pcs per reel)
- RoHS2011/65/EU
- Mechanism to avoid flying out of the card
- Small size (Ht. 3.1 x W. 28.0 x L. 29.8)
- 2-point contact, protection against electrical interruption
- Card detector and Write protection switch

PART NUMBER

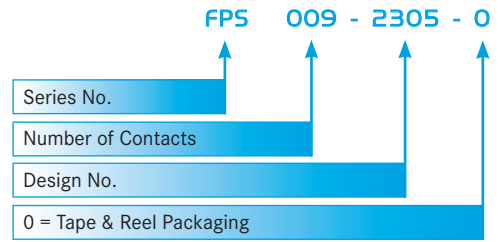

AUTOMOTIVE COMPLIANT



OUTLINE DIMENSIONS

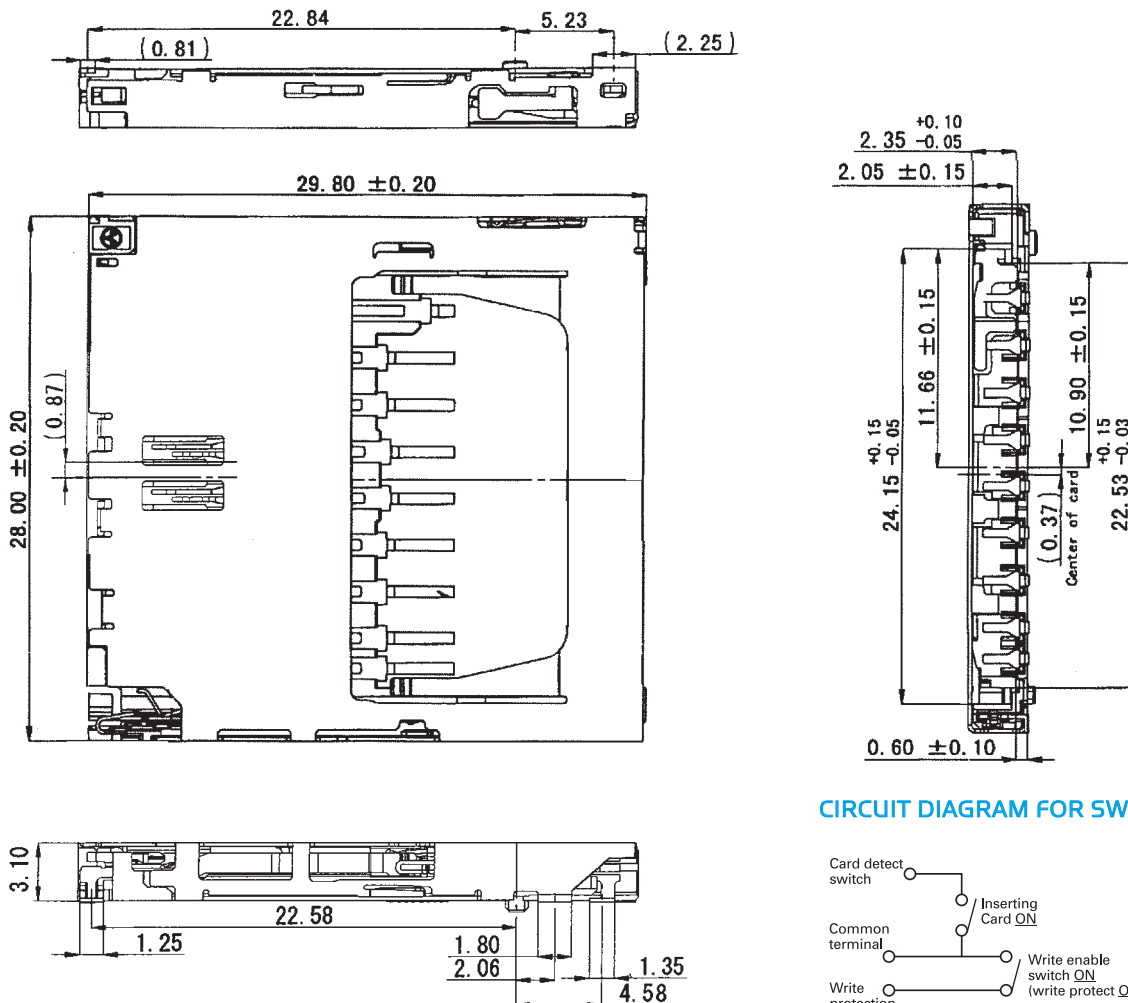

CIRCUIT DIAGRAM FOR SWITCH

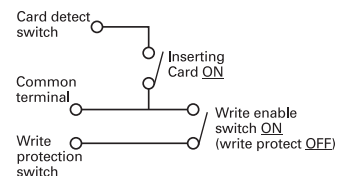

RECOMMENDED PCB LAYOUT FOR FPS009-2305-0

Top View

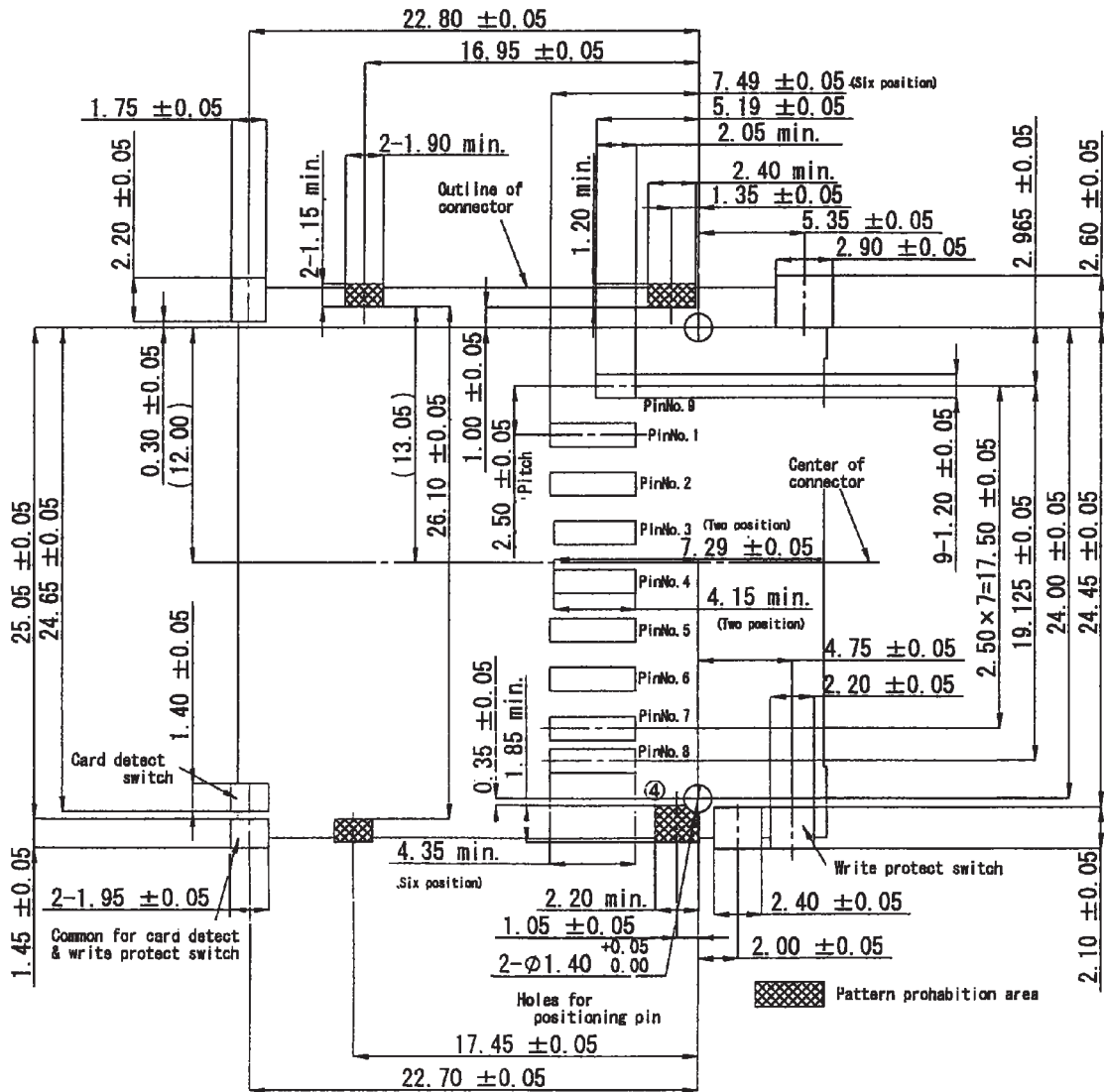

CARD INSERTION DETAILS

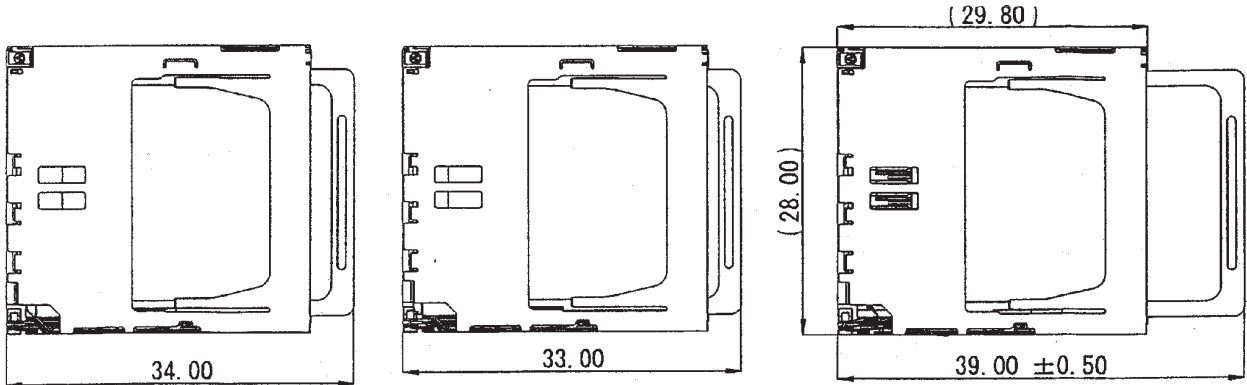

Card locked position

Card pushed position

Card eject position

SPECIFICATIONS

Insulation Resistance:	500MΩ min. at 500V DC
Withstanding Voltage:	500V ACrms for 1 minute
Contact Resistance:	100mΩ at 1mA / 20mV max.
Voltage Rating:	5Vrms AC
Current Rating:	0.5A
Operating Temp. Range:	-25°C to +85°C
Coplanarity:	≤ 0.1mm
Mating Cycles:	10,000 times (office environment)

MATERIALS AND FINISH

Insulator:	LCP
Shielding plate:	Stainless
Contact:	Copper Alloy
	Contact Area: Ni-Au
	Solder Tail: Ni-Sn



FEATURES

- Connector for both card types (MMC and SD card)
- For assembly underneath the PC-board (reversed)
- Smooth extraction function by Push-in/ Push-out of card
- EMI prevention
- SDIO capable
- RoHS2011/65/EU
- Card detector
- Write protection switch
- Card mis-insertion prevention design
- Soft lock mechanism for SD card
- Card fly-out stop design
- Tape & Reel packaging (500 pcs / reel)

PART NUMBER

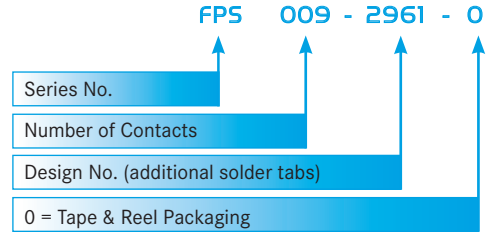
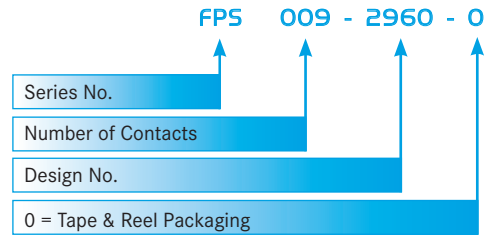

OUTLINE DIMENSIONS

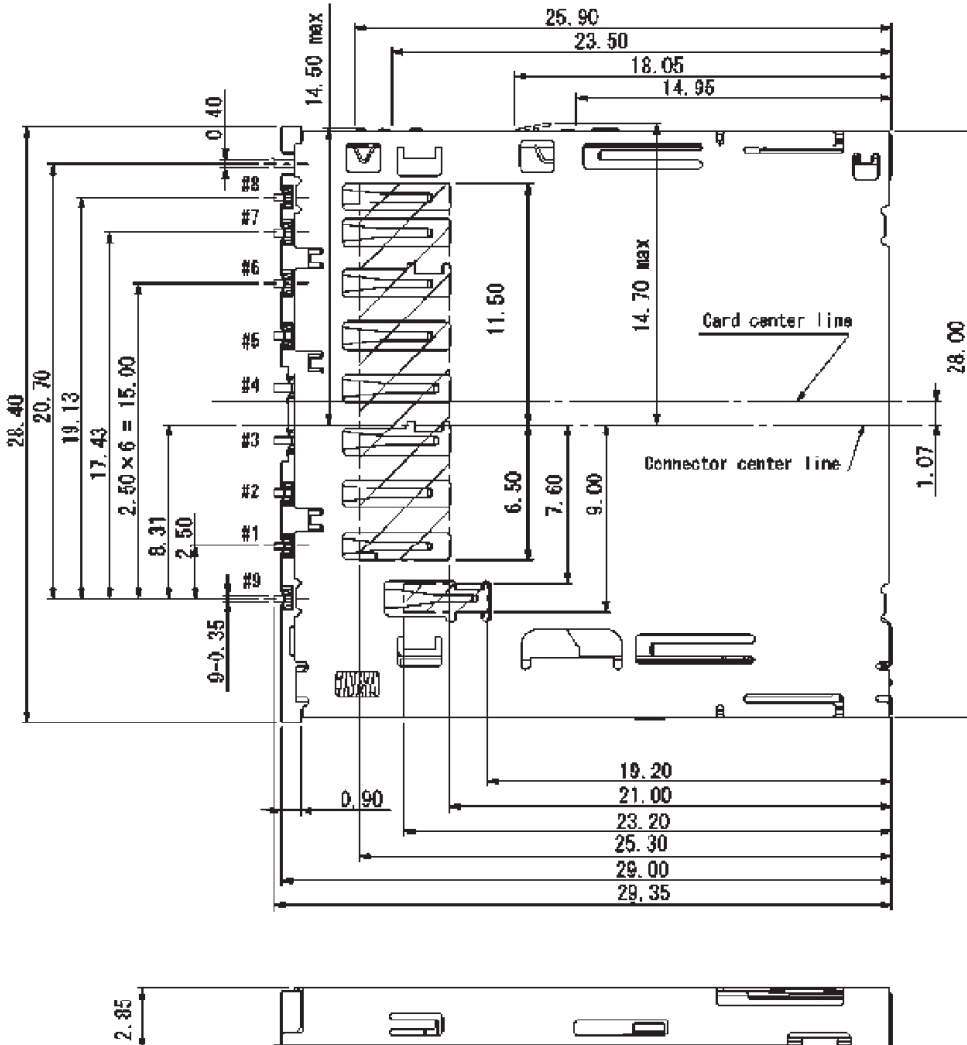

RECOMMENDED PCB LAYOUT FPS009-2960-0

Top View

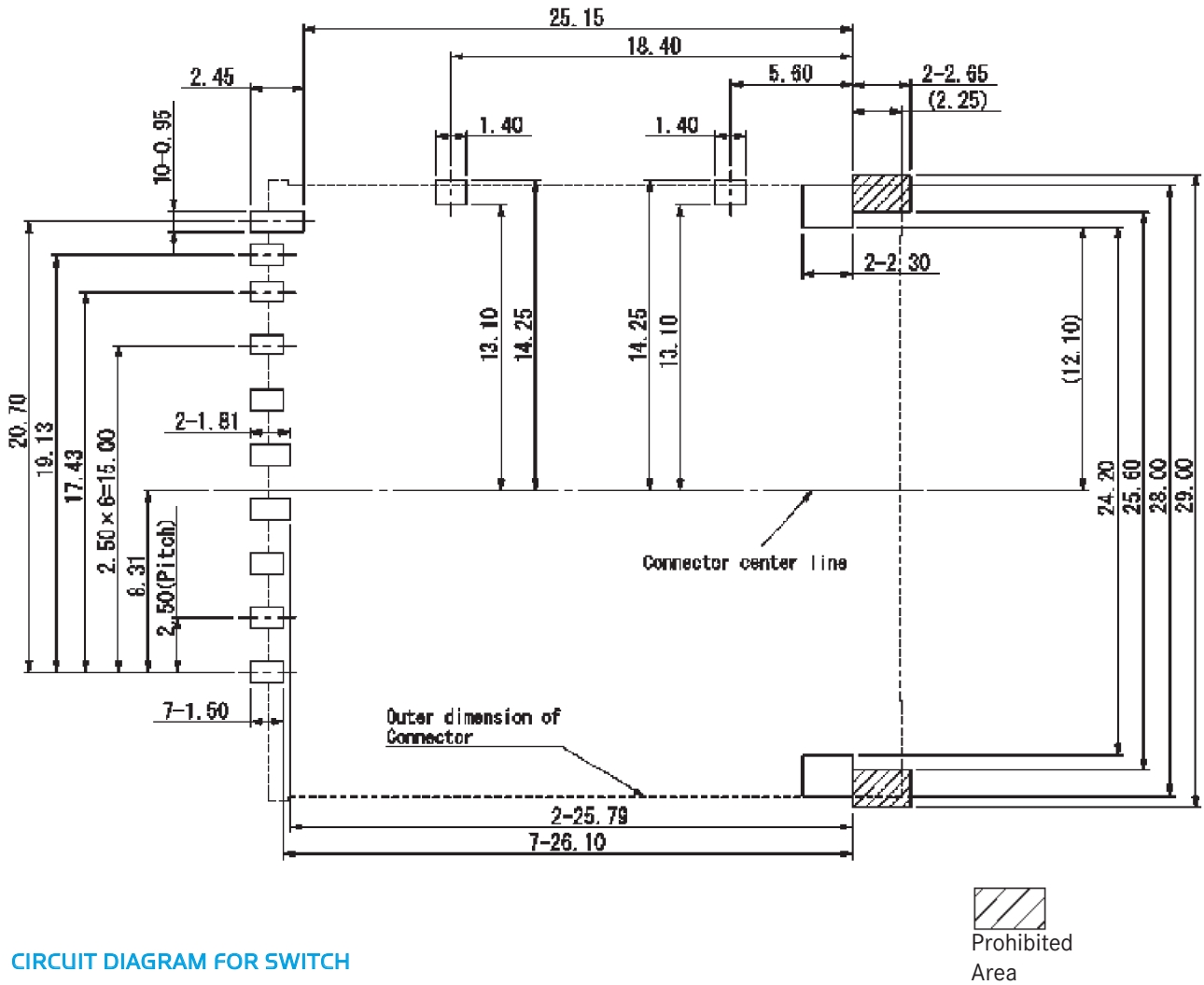

CIRCUIT DIAGRAM FOR SWITCH

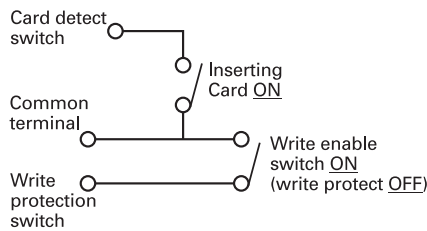

CARD INSERTION DETAILS

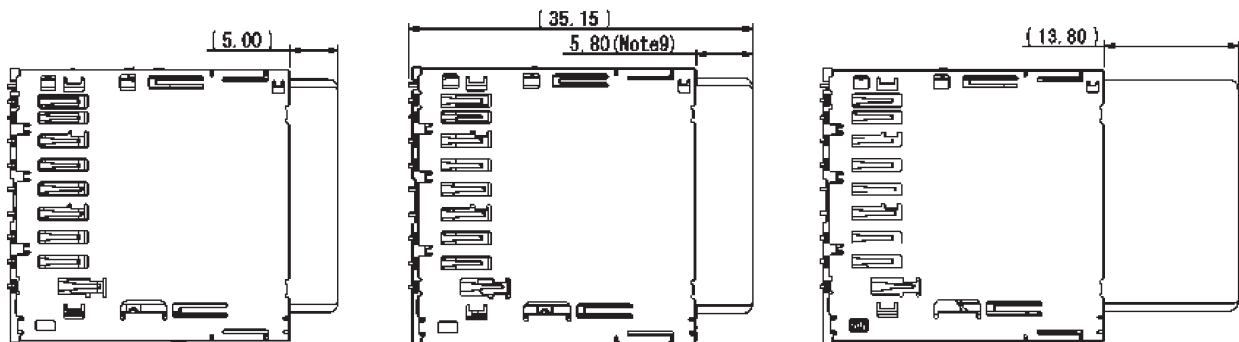

Card pushed position

Card locked position

Card eject position

SPECIFICATIONS

Insulation Resistance:	1,000MΩ min. at 500V DC
Withstanding Voltage:	500V ACrms for 1 minute
Contact Resistance:	100mΩ at 1mA / 40mV max.
Voltage Rating:	5V DC
Current Rating:	0.5A
Operating Temp. Range:	-25°C to +85°C
Mating Cycles:	10,000 (office environment)

MATERIALS AND FINISH

Insulator:	LCP
Shielding plate:	Stainless
Contact:	Copper Alloy: t=0.15
Contact Area:	Ni-Au
Solder Tail:	Ni-Sn

FEATURES

- Card stay detection switch at the slot area
- EMI prevention with four grounding terminals
- Smooth extraction function by Push-in/ Push-out of card
- Write protection switch
- SDIO capable
- Tape & Reel packaging (500 pcs / reel)
- RoHS2011/65/EU

PART NUMBER

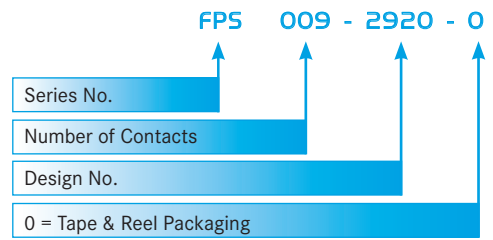

AUTOMOTIVE COMPLIANT



OUTLINE DIMENSIONS

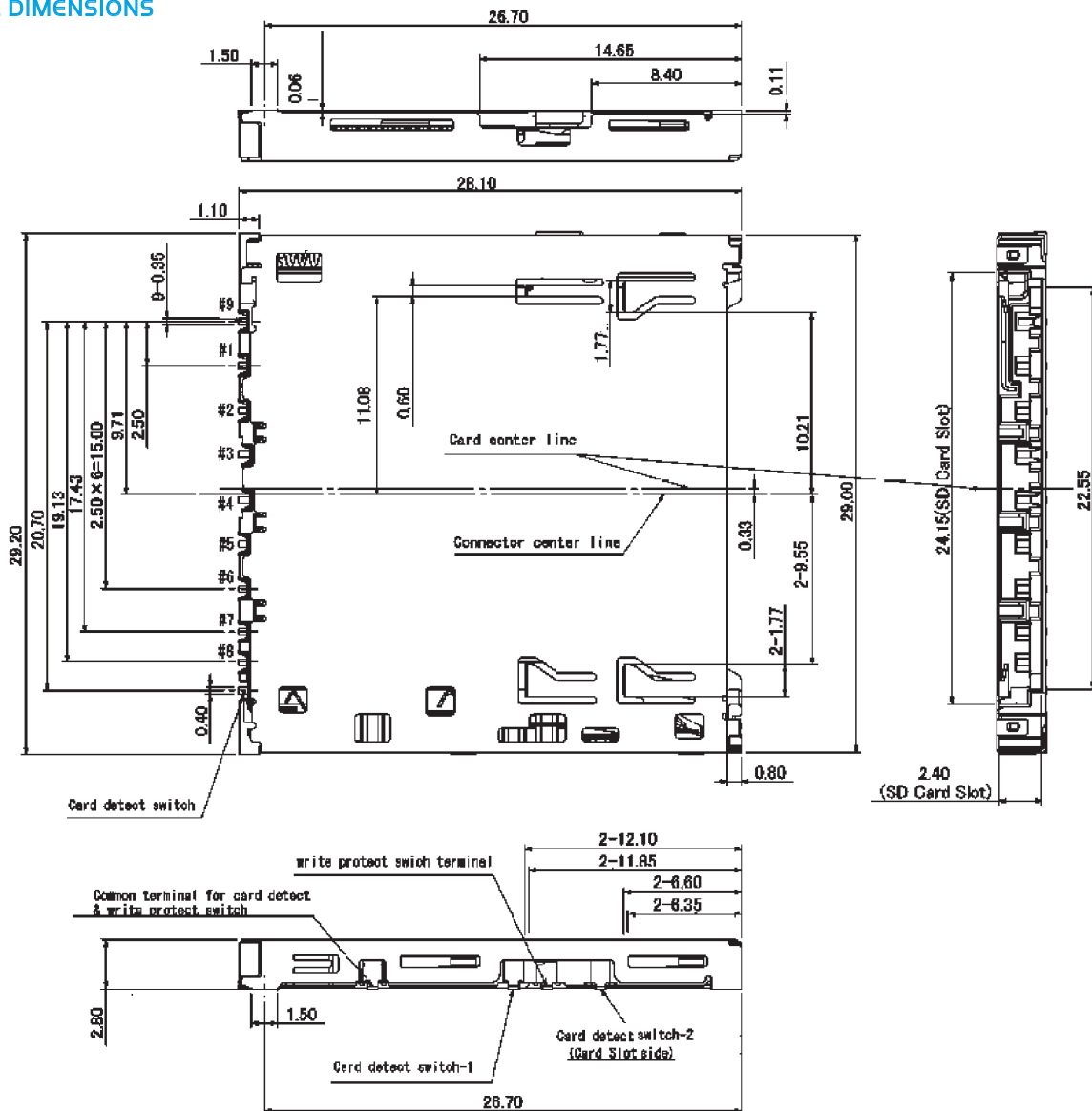

RECOMMENDED PCB LAYOUT FOR FP5009-2920-0

Top View

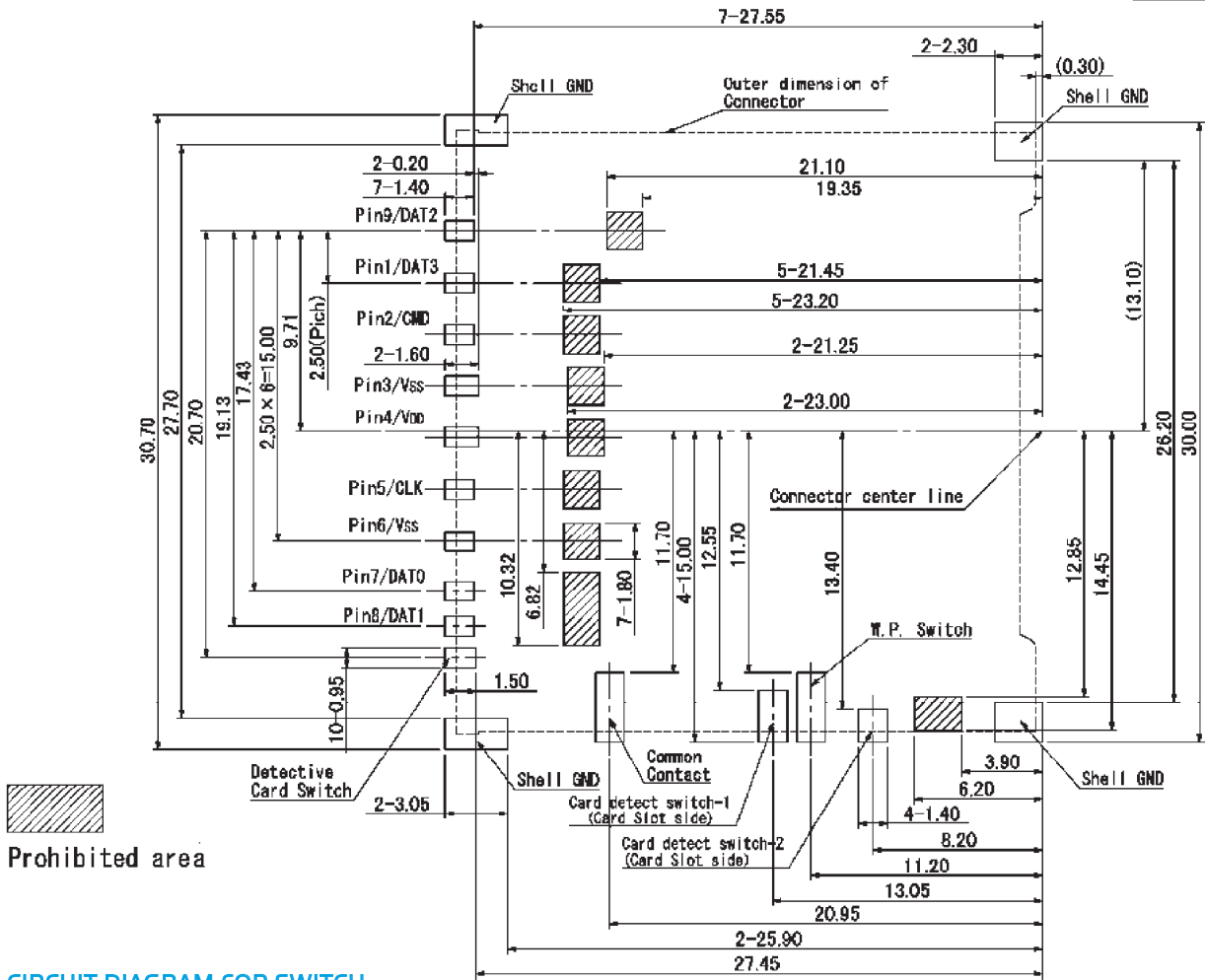

CIRCUIT DIAGRAM FOR SWITCH

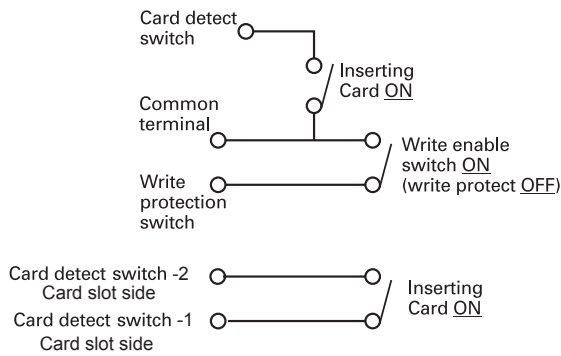

CARD INSERTION DETAILS

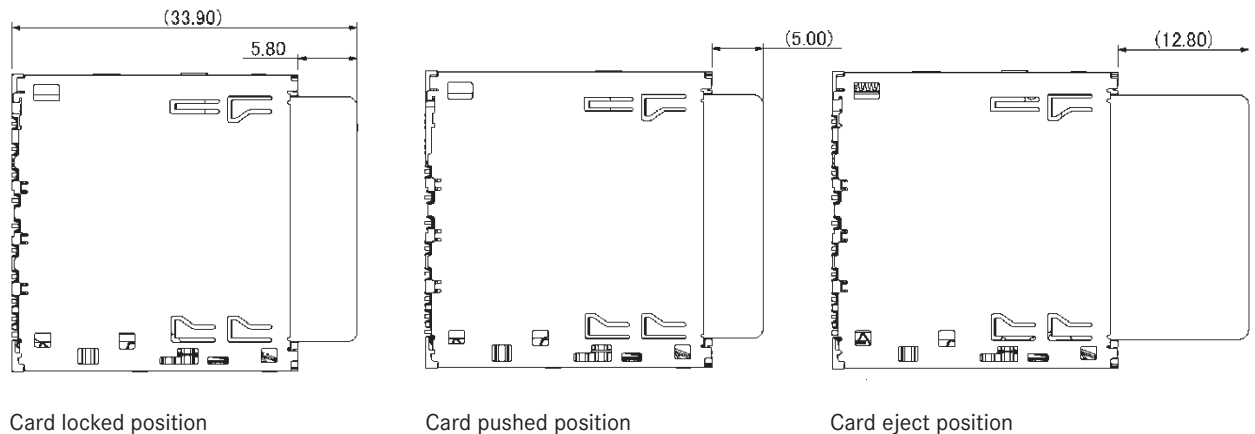

SPECIFICATIONS

Insulation Resistance:	1,000MΩ min. at 500V DC
Withstanding Voltage:	500V ACrms for 1 minute
Contact Resistance:	100mΩ at 1mA / 40mV max.
Voltage Rating:	5V DC
Current Rating:	0.5A
Operating Temp. Range:	-25°C to +85°C
Mating Cycles:	10,000 (office environment)

MATERIALS AND FINISH

Insulator:	LCP
Shielding plate:	Stainless
Contact:	Copper Alloy: t=0.15
	Contact Area: Ni-Au
	Solder Tail: Ni-Sn

FEATURES

- Card stay detection switch at the slot area
- EMI prevention with four grounding terminals
- Smooth extraction function by Push-in/ Push-out of card
- Write protection switch
- SDIO capable
- Tape & Reel packaging (400 pcs / reel)
- RoHS2011/65/EU

PART NUMBER

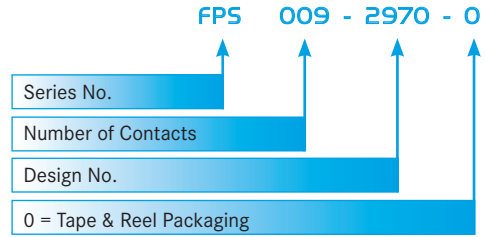

AUTOMOTIVE COMPLIANT



OUTLINE DIMENSIONS

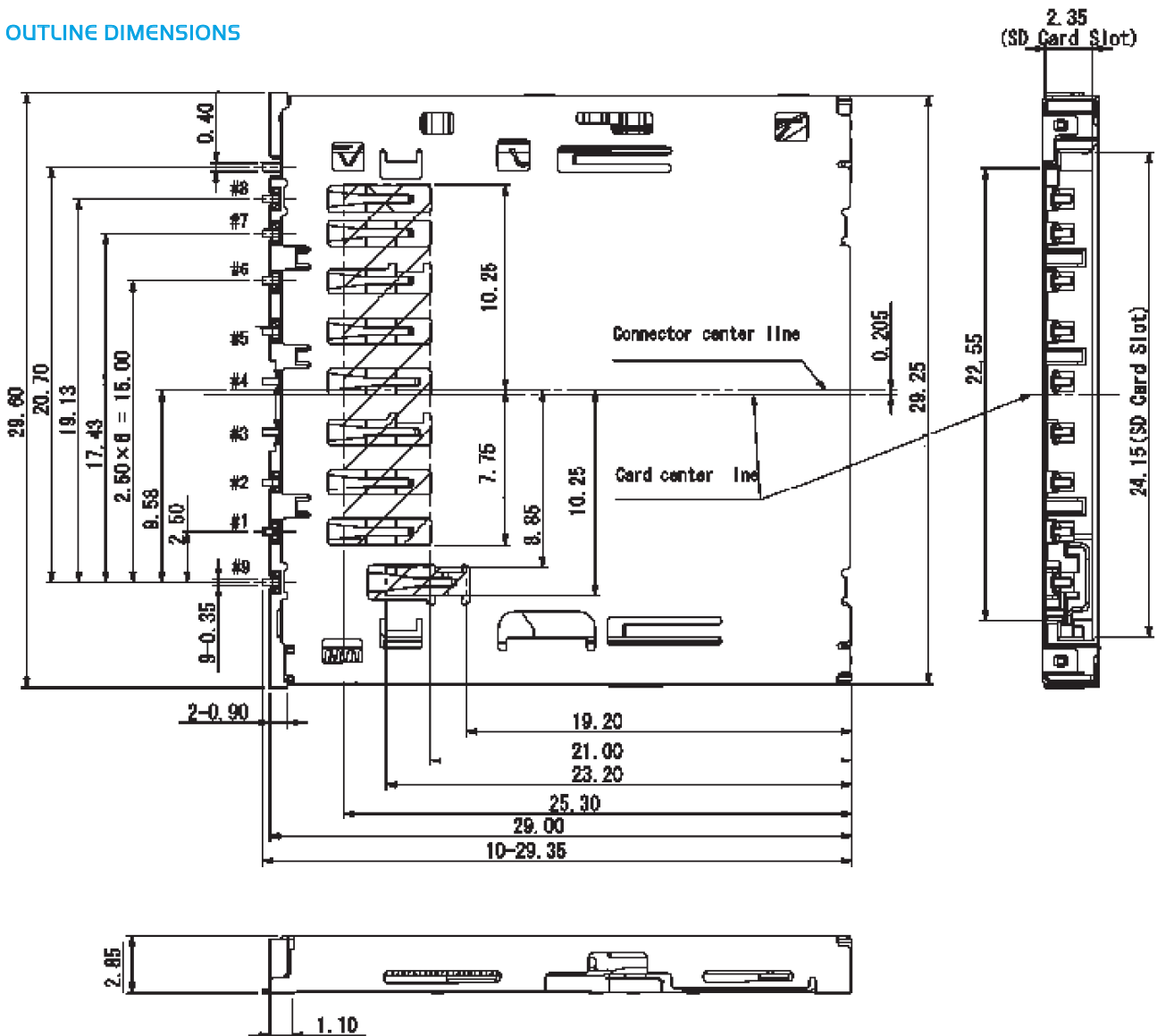

RECOMMENDED PCB LAYOUT FOR FP5009-2970-0

Top View

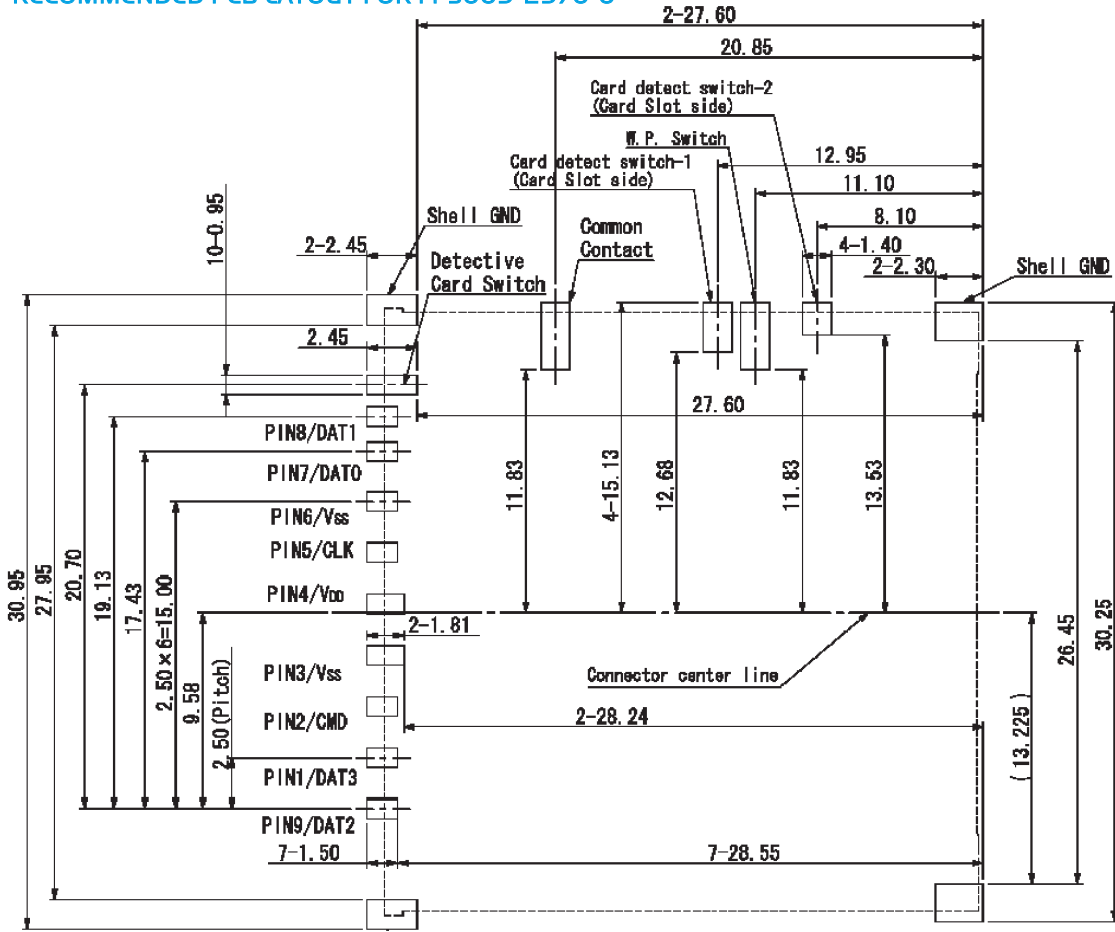

CIRCUIT DIAGRAM FOR SWITCH

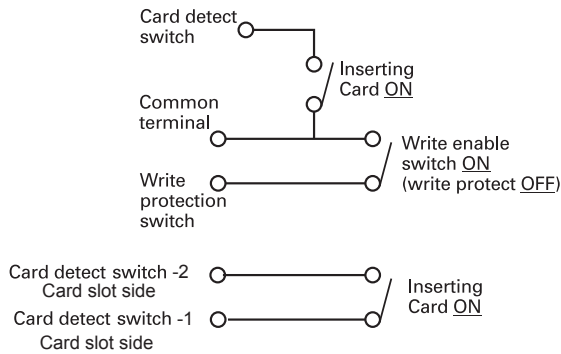

CARD INSERTION DETAILS

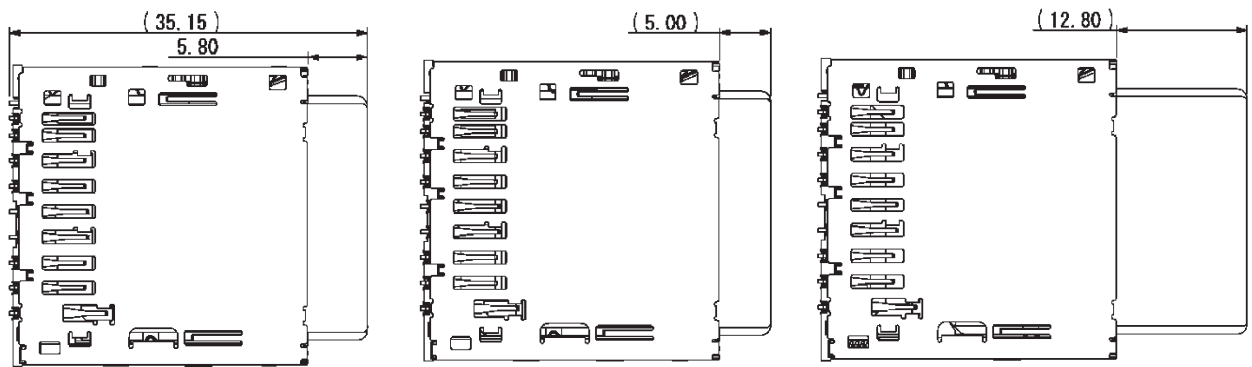

Card locked position

Card pushed position

Card eject position

SPECIFICATIONS

Insulation Resistance:	1,000MΩ min. at 500V DC
Withstanding Voltage:	500V ACrms for 1 minute
Contact Resistance:	100mΩ at 1mA / 20mV max.
Voltage Rating:	250Vrms AC
Current Rating:	0.5A
Operating Temp. Range:	-25°C to +85°C
Coplanarity:	≤ 0.15mm
Mating Cycles:	10,000 (office environment)

PART NUMBER

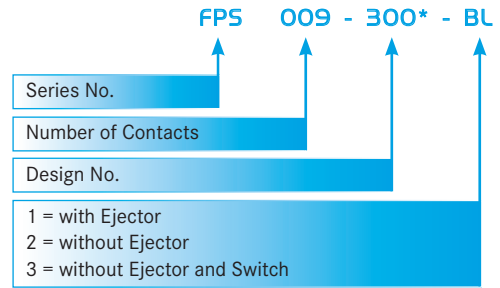

MATERIALS AND FINISH

Insulator:	LCP
Shielding plate:	Stainless, t = 0.23
Contacts:	Copper Alloy
	Contact Area = Ni-Au
	Solder Tails = Ni-SnCu
Write Protection:	Copper Alloy, Ni-Au
Card Detector:	Copper Alloy, Ni-Au
Ejector:	LCP

FEATURES

- Easy operation by manual insertion / extraction
- 3 step sequential contacting design
- Card detector and write protection (optional)
- Tape and Reel packaging (500 pcs / reel)
- RoHS2011/65/EU

AUTOMOTIVE COMPLIANT

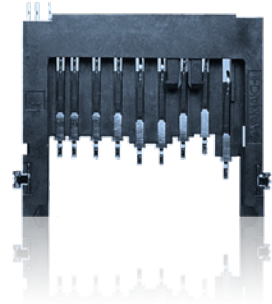

OUTLINE DIMENSIONS

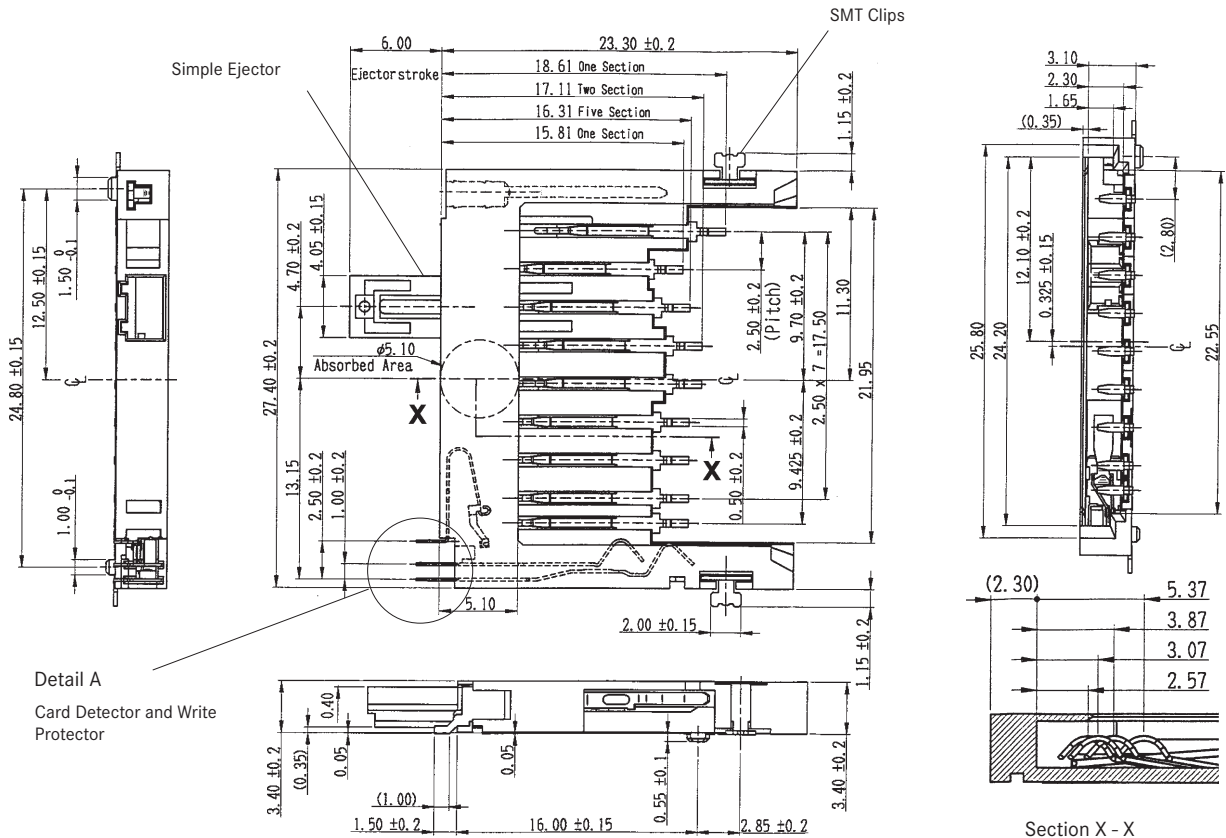

FUNCTION TABLE

Part Number	Ejector	Card Detector	SMT Clips	Write Protection Switch
FPS009-3001-BL	Yes	Yes	Yes	Yes
FPS009-3002-BL	-	Yes	Yes	Yes
FPS009-3003-BL	-	-	Yes	-

SPECIFICATIONS

Insulation Resistance:	1,000MΩ min. at 500V DC
Withstanding Voltage:	500V ACrms for 1 minute
Contact Resistance:	100mΩ at 1mA / 20mV max.
Voltage Rating:	250Vrms AC
Current Rating:	0.5A
Operating Temp. Range:	-25°C to +85°C
Coplanarity:	≤ 0.15mm
Mating Cycles:	10,000 (office environment)

PART NUMBER

FPS 009 - 3202-BL



MATERIALS AND FINISH

Insulator:	LCP
Plate:	Stainless Steel
Contacts:	Copper Alloy
	Contact Area = Ni-Au
	Solder Tails = Ni-Sn
Write Protection:	Copper Alloy, Ni-Au
Card Detector:	Copper Alloy, Ni-Au

FEATURES

- Connector for both card types (SD and MMC card)
- Easy operation by manual insertion / extraction
- Short housing (20.3mm instead of 23.3mm)
- 3 step sequential contacting design
- With card retention mechanism
- With card detector and write protection
- Tape and Reel packaging
- RoHS2011/65/EU

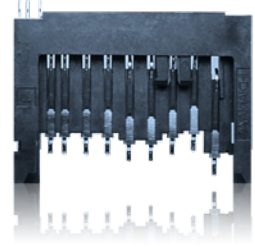

OUTLINE DIMENSIONS

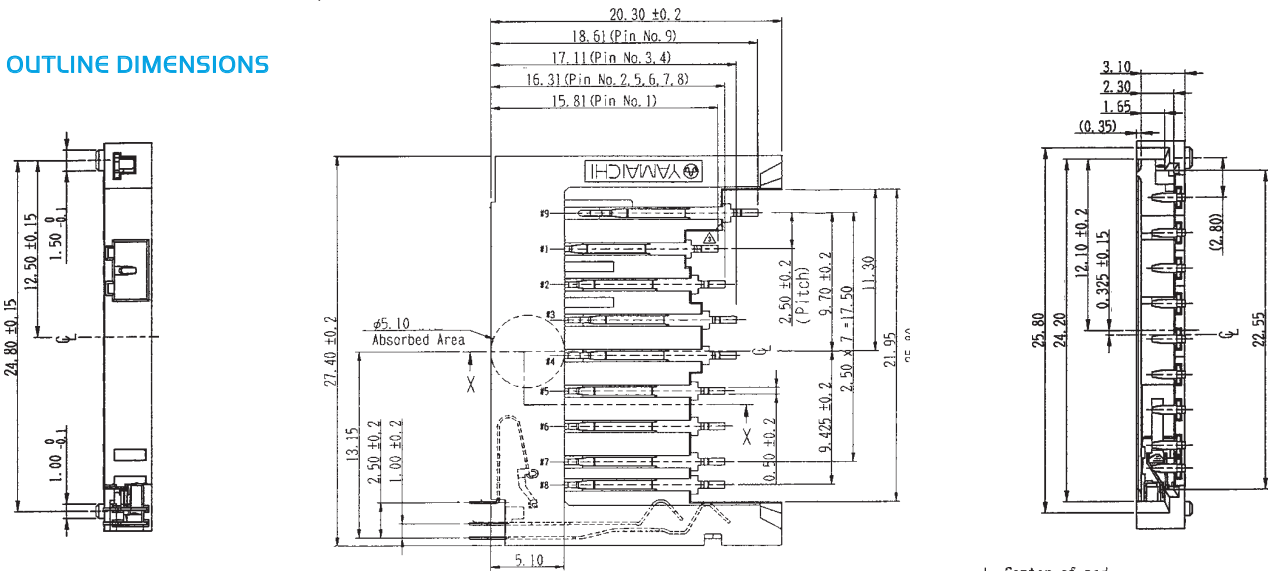

RECOMMENDED PCB LAYOUT

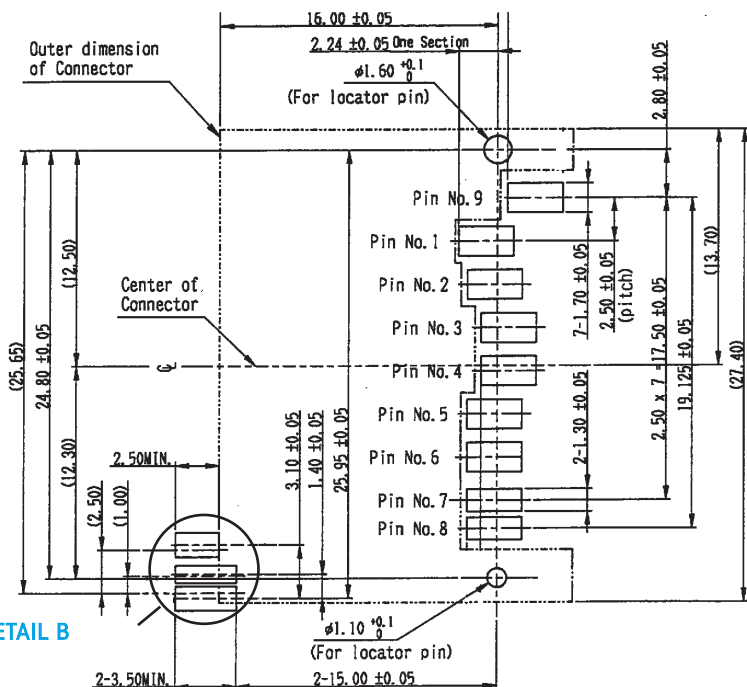

DETAIL B

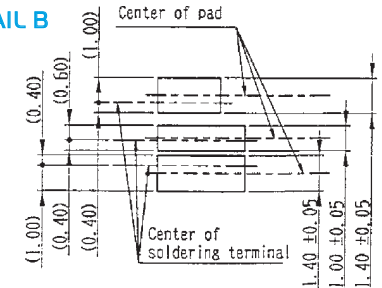

CIRCUIT DIAGRAM FOR SWITCH

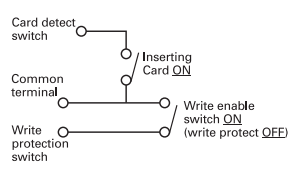

DETAIL A (CARD DETECTOR / WRITE PROTECTOR)

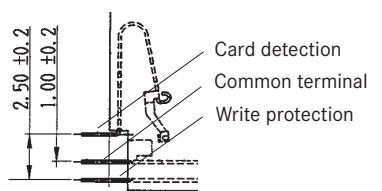

SPECIFICATIONS

Insulation Resistance:	1,000MΩ min. at 500V DC
Withstanding Voltage:	500V ACrms for 1 minute
Contact Resistance:	100mΩ at 1mA / 20mV max.
Voltage Rating:	5V DC
Current Rating:	0.5A max.
Operating Temp. Range:	-30°C to +85°C
Mating Cycles:	100

MATERIALS AND FINISH

Insulator:	LCP
Contact:	Copper Alloy, Ni-Au

FEATURES

- Automatic locking function after insertion of SD card
- 2-point contact installation on all contact-terminals to ensure die-electric discontinuity prevention which may be caused by vibration and impact
- Zero sliding contact @100G shock (X Y Z direction)
- Metal shell cover with 4 GNDs (Solder tubs) to ensure EMI/ESD prevention performance
- RoHS2011/65/EU

PART NUMBER

FPS 009 - 4200-0 (03)



AUTOMOTIVE COMPLIANT

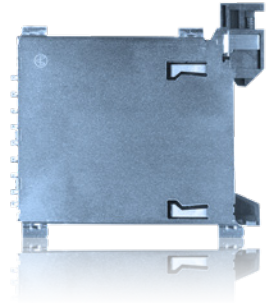

OUTLINE DIMENSIONS

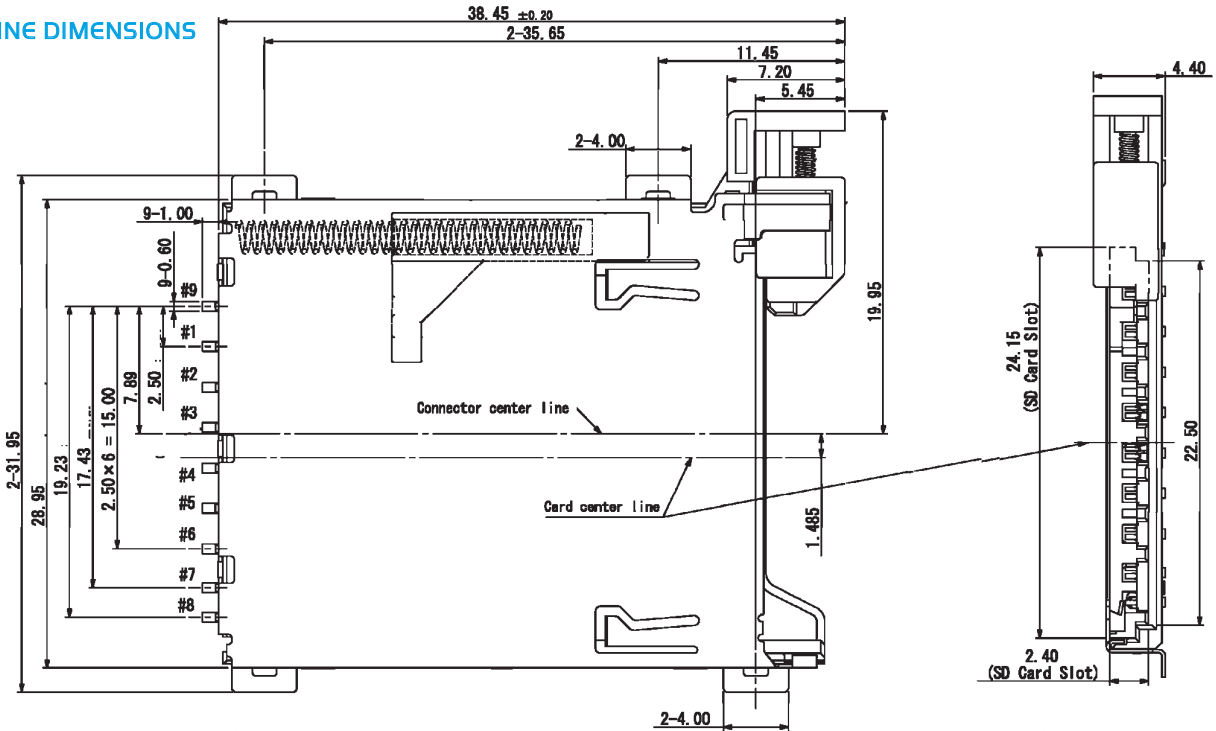

RECOMMENDED PCB LAYOUT

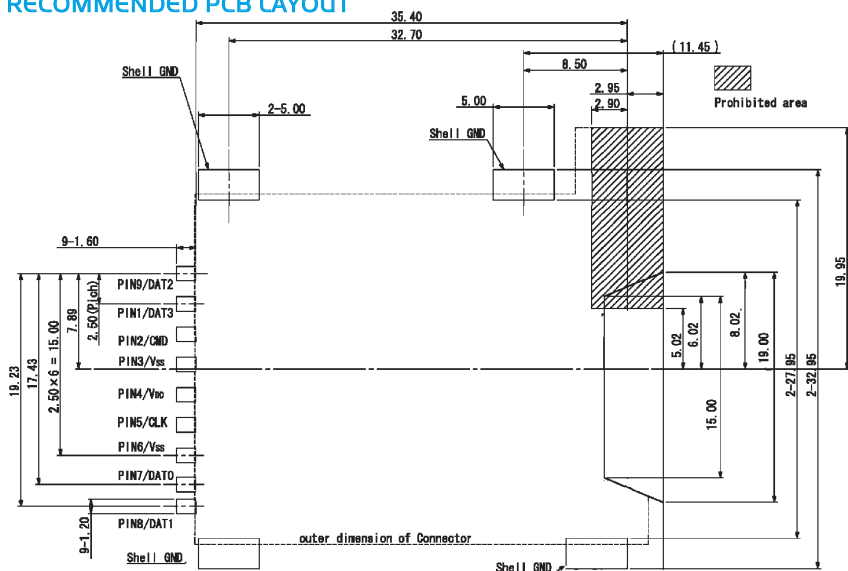

CARD INSERTION DETAILS

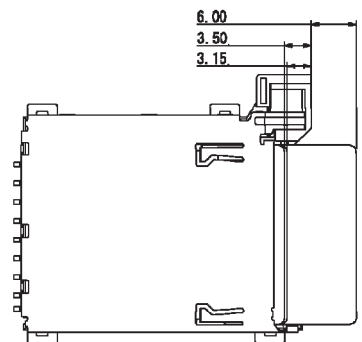

SPECIFICATIONS

Insulation Resistance:	1,000MΩ min. at 500V DC
Withstanding Voltage:	250V ACrms for 1 minute
Contact Resistance:	100mΩ max.
Voltage Rating:	5V DC
Current Rating:	1A max.
Operating Temp. Range:	-20°C to +60°C
Mating Cycles:	10,000

MATERIALS AND FINISH

Insulator:	LCP rated (UL94V-0) black
Contacts:	Phosphor Bronze at contact area
Contact Plating:	Selective Gold over Nickel
Shell:	Stainless Steel

FEATURES

- SD Card Reader according to Spec SD4.0
- Push/Push type with soft locking mechanism
- With card detection switch
- RoHS2011/65/EU

OUTLINE DIMENSIONS

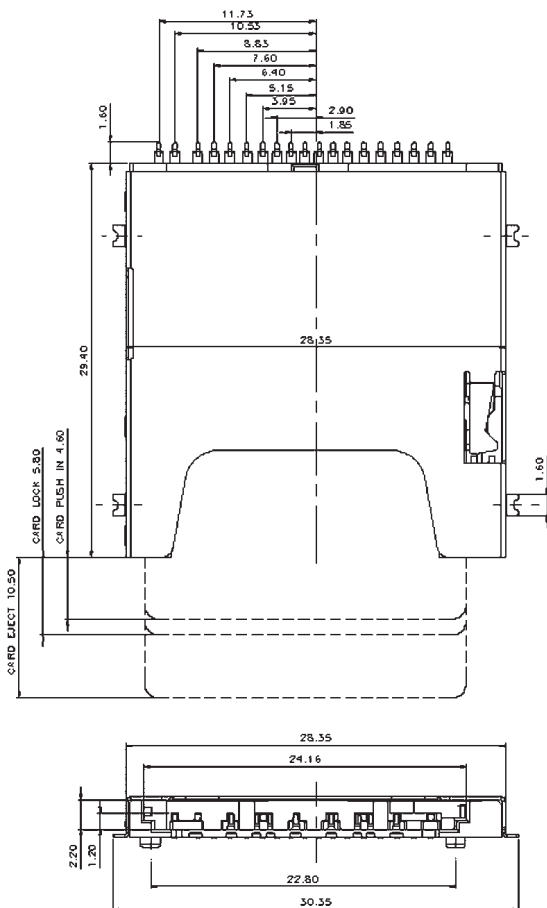

PART NUMBER

FPS O17T - 2000 - FL - TRAY

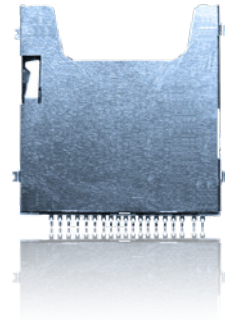
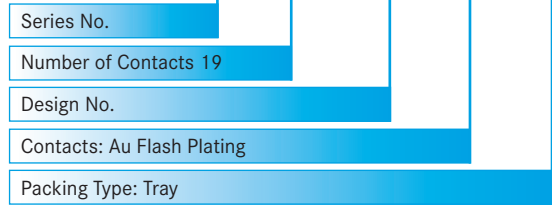

RECOMMENDED PCB LAYOUT

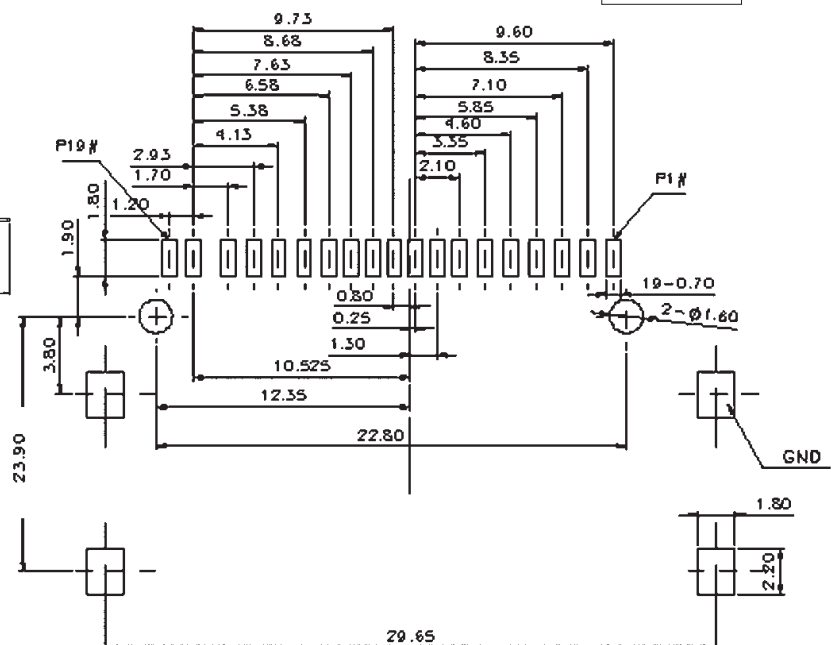

SPECIFICATIONS

Insulation Resistance:	1,000MΩ min. at 500V DC
Withstanding Voltage:	500V AC rms for 1 minute
Contact Resistance:	100mΩ at 1mA / 20mV max.
Voltage Rating:	50Vrms AC
Current Rating:	0.5A
Operating Temp. Range:	-25°C to +85°C
Coplanarity:	≤ 0.1mm
Reflow Temp.:	220°C for max.60 secs.,260° peak / 10 secs
Mating Cycles:	10,000 (office environment)

PART NUMBER

PJS 008 - 2130 - 0

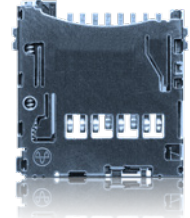
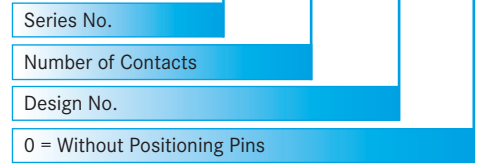

MATERIALS AND FINISH

Insulator:	LCP
Shielding Plate:	Stainless
Contacts:	Copper Alloy, Ni-Au

FEATURES

- Super low profile of 1.5mm
- Smooth extraction function by Push-in / Push-out of card
- Card detector and lock mechanism
- RoHS2011/65/EU
- Top Mount
- Special card brake (independent from card thickness)
- Tape & Reel packaging 1,500 pcs per reel

OUTLINE DIMENSIONS FOR PJS008-2130-1

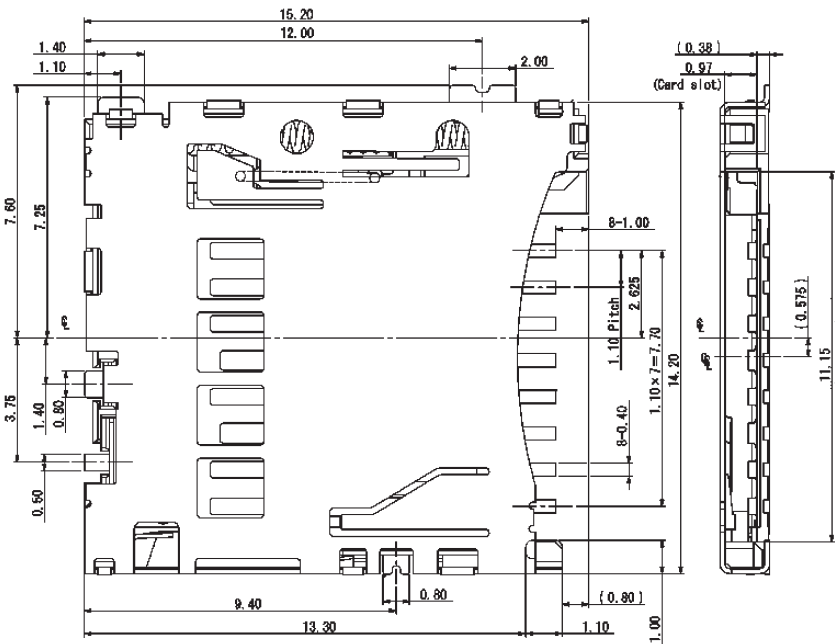

CARD INSERTION DETAILS

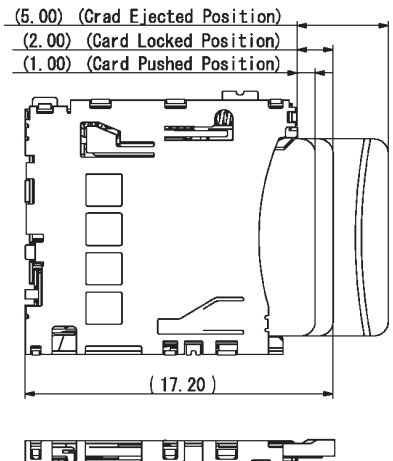

RECOMMENDED PCB LAYOUT

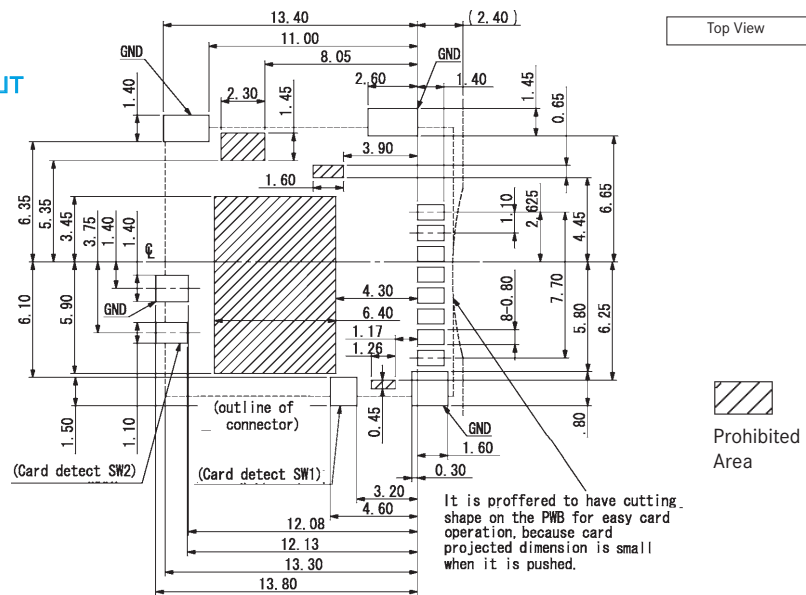

SPECIFICATIONS

Insulation Resistance:	500MΩ min. at 500V DC
Withstanding Voltage:	500V AC rms for 1 minute
Contact Resistance:	100mΩ at 1mA / 20mV max.
Voltage Rating:	50Vrms AC
Current Rating:	0.5A
Operating Temp. Range:	-25°C to +85°C
Coplanarity:	≤ 0.1mm
Reflow Temp.:	220°C for max.60 secs.,260° peak / 10 secs.
Mating Cycles:	10,000 (office environment)

MATERIALS AND FINISH

Insulator:	LCP
Shielding Plate:	Stainless
Contacts:	Copper Alloy, Ni-Au

FEATURES

- Super low profile of 1.5mm
- Smooth extraction function by Push-in/Push-out of card
- Card detector and lock mechanism
- Tape & Reel packaging 1,500 pcs per reel
- Top Mount
- Special card brake (independent from card thickness)
- Lubricant assisted coil spring to slow card coming out
- RoHS2011/65/EU

PART NUMBER

PJS OOB - 2120-0

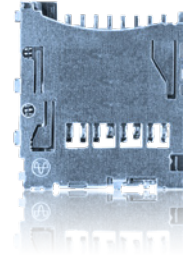

OUTLINE DIMENSIONS

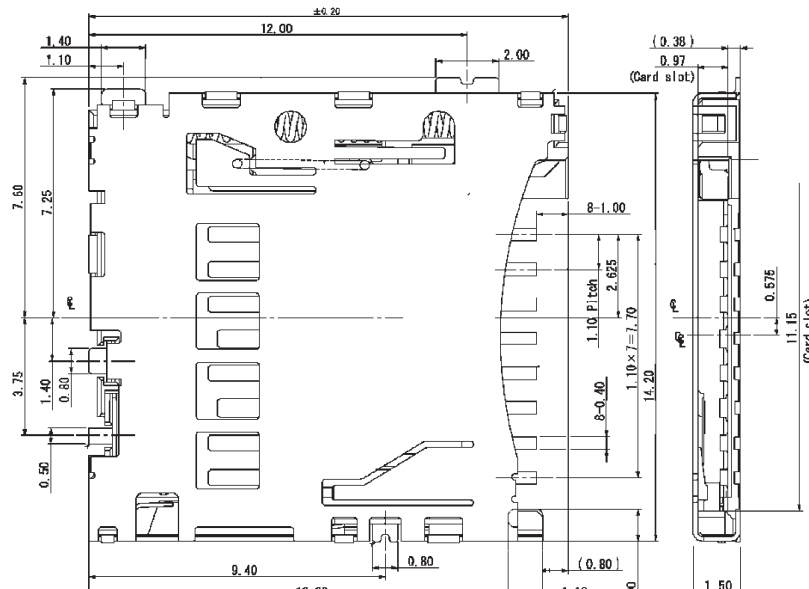

RECOMMENDED PCB LAYOUT

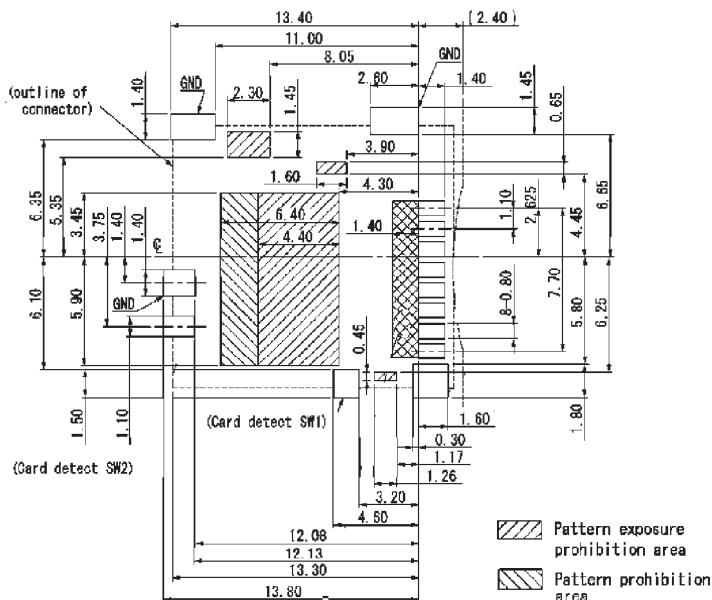

CARD INSERTION DETAILS

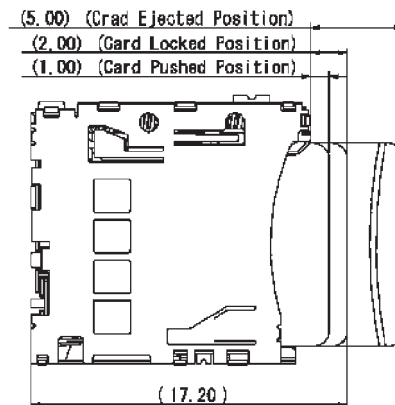

SPECIFICATIONS

Insulation Resistance:	1,000MΩ min. at 500V DC
Withstanding Voltage:	500V ACrms for 1 minute
Contact Resistance:	100mΩ at 1mA / 20mV max.
Voltage Rating:	50Vrms AC
Current Rating:	0.5A
Operating Temp. Range:	-25°C to +85°C
Mating Cycles:	10,000 (office environment) 3,000 (harsh environment)

PART NUMBER

PJS O08 - 2004 - * - VE

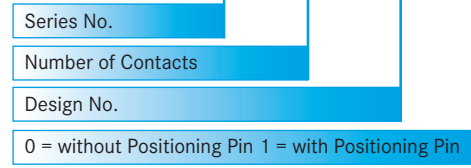

MATERIALS AND FINISH

Insulator:	LCP
Shielding Plate:	Stainless
Contacts:	Copper Alloy, Ni-Au

FEATURES

- Improved card detection feature, no wrong insertion of the card is possible
- Soft lock mechanism
- Card detection switch
- Tape & Reel packaging, 1,000 pcs. per reel
- RoHS2011/65/EU

AUTOMOTIVE COMPLIANT

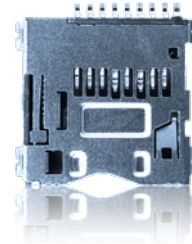

OUTLINE DIMENSIONS

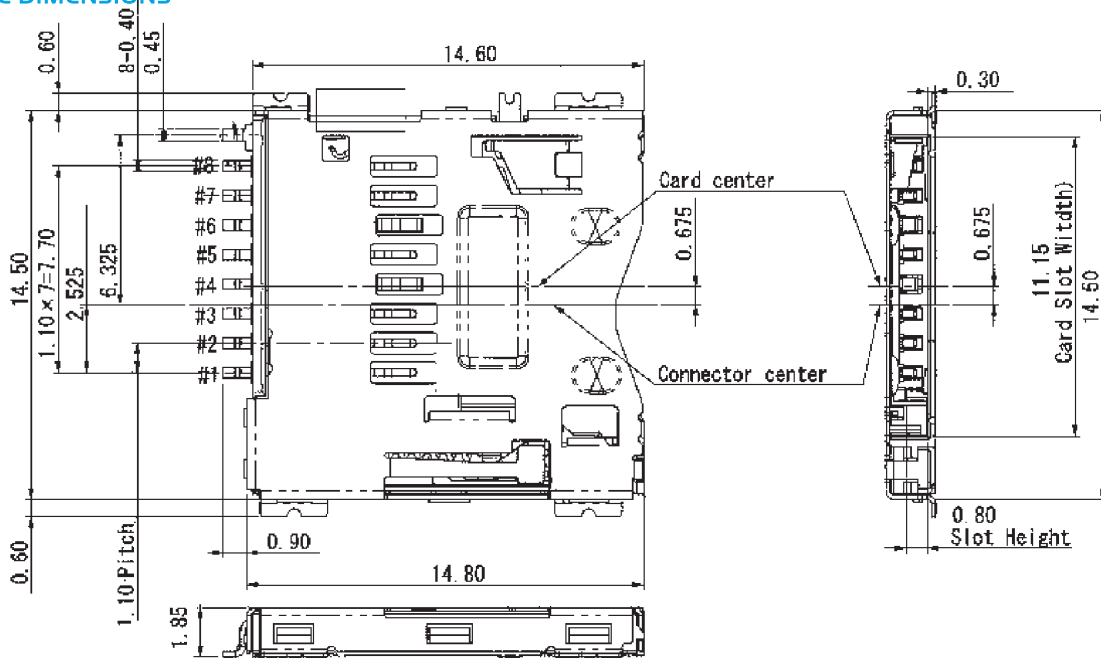

RECOMMENDED PCB LAYOUT

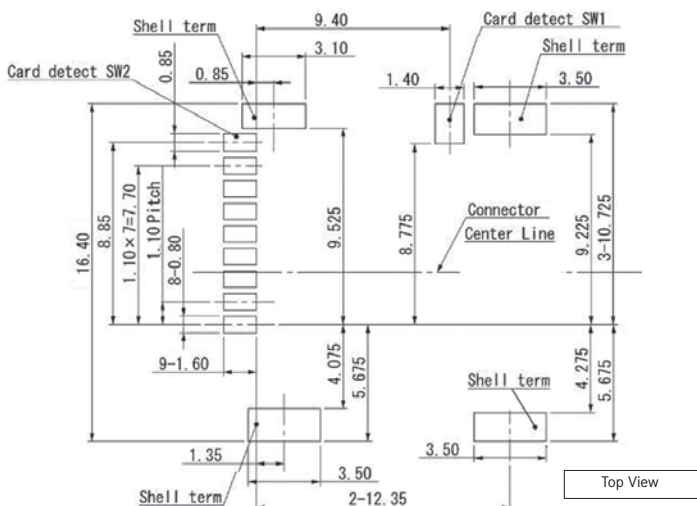

CARD INSERTION DETAILS

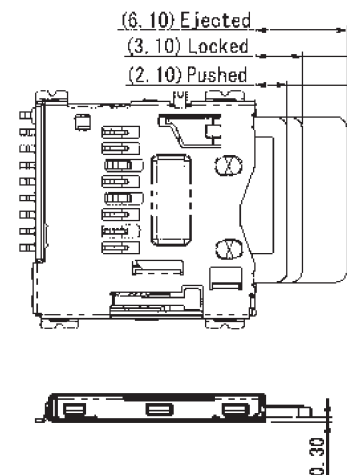

SPECIFICATIONS

Insulation Resistance:	1,000MΩ min. at 500V DC
Withstanding Voltage:	500V ACrms for 1 minute
Contact Resistance:	100mΩ at 1mA / 20mV max.
Voltage Rating:	50Vrms AC
Current Rating:	0.5A
Operating Temp. Range:	-25°C to +85°C
Mating Cycles:	10,000 (office environment) 3,000 (harsh environment)

PART NUMBER

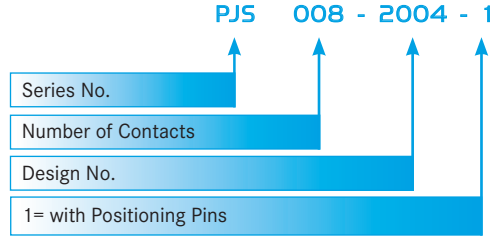

MATERIALS AND FINISH

Insulator:	LCP
Shielding Plate:	Stainless
Contacts:	Copper Alloy, Ni-Au

FEATURES

- Improved card detection feature, no wrong insertion of the card is possible
- Soft lock mechanism
- Card detection switch
- Tape & Reel packaging, 1,000 pcs. per reel
- RoHS2011/65/EU

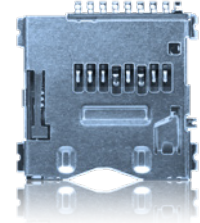

OUTLINE DIMENSIONS

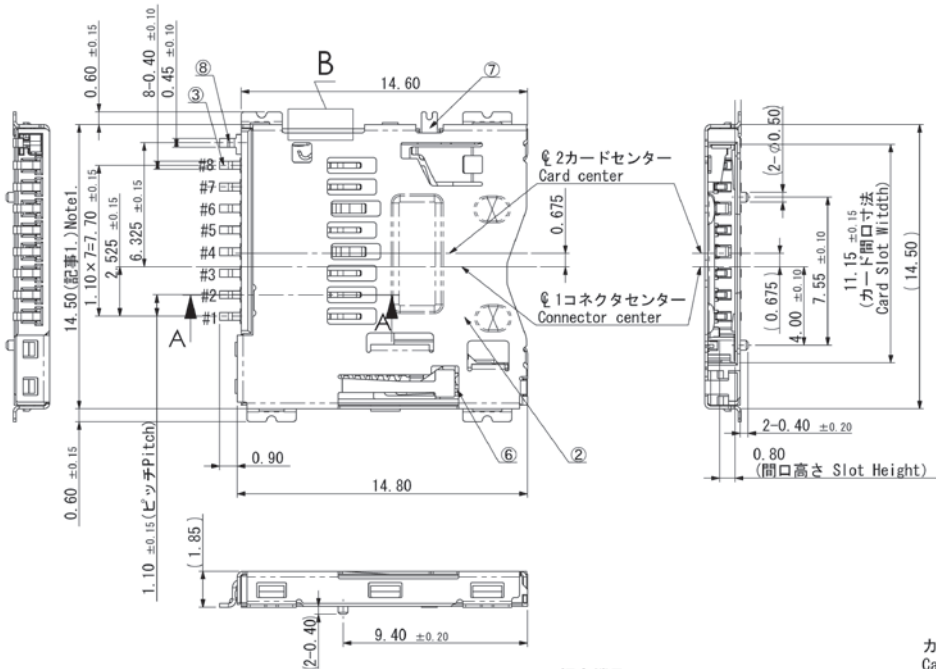

RECOMMENDED PCB LAYOUT

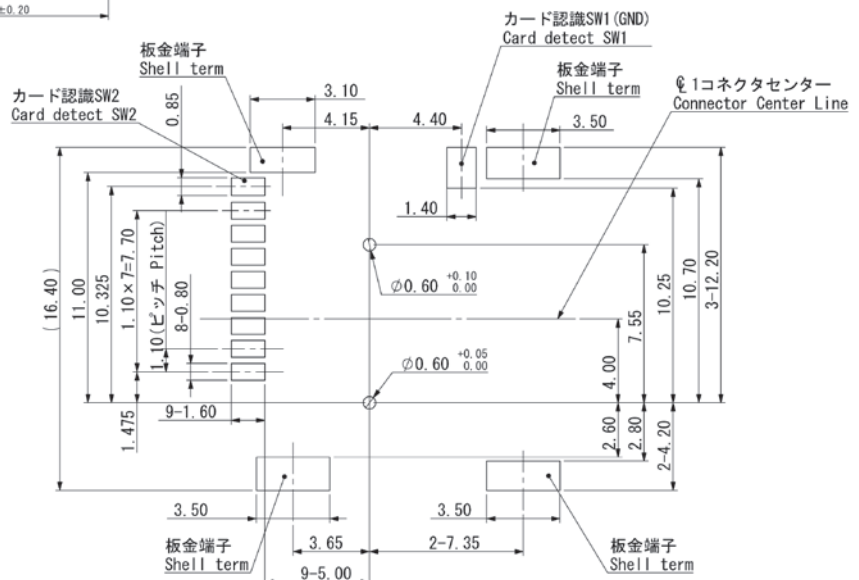

SPECIFICATIONS

Insulation Resistance:	1,000MΩ min. at 500V DC
Withstanding Voltage:	500V ACrms for 1 minute
Contact Resistance:	100mΩ at 1mA / 20mV max.
Voltage Rating:	50Vrms AC
Current Rating:	0.5A
Operating Temp. Range:	-25°C to +85°C
Coplanarity:	≤ 0.1mm
Reflow Temp.:	220°C for max. 60 secs., 260° peak
Mating Cycles:	10,000 (office environment)

MATERIALS AND FINISH

Insulator:	LCP
Shielding Plate:	Stainless
Contacts:	Copper Alloy, Ni-Au

FEATURES

- Strong contact reliability for enhanced vibration and shock in automotive by using dual contact
- Minimized design. W = 14.5 x L = 14.8mm
- Smooth extraction function by Push-in/Push-out
- With card detection
- Reverse mount
- Tape and Reel packaging 1,000 pcs. per reel
- RoHS2011/65/EU

OUTLINE DIMENSIONS

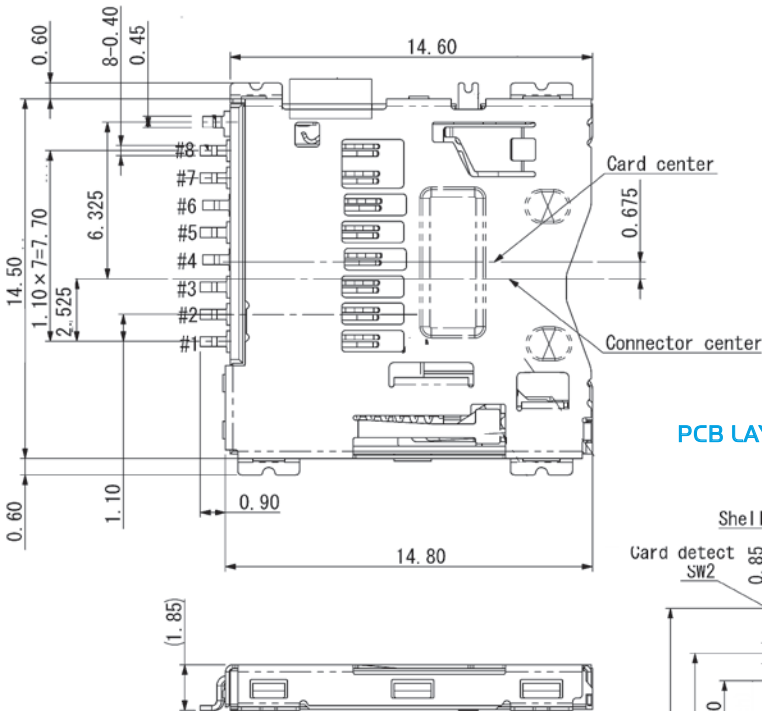

PART NUMBER

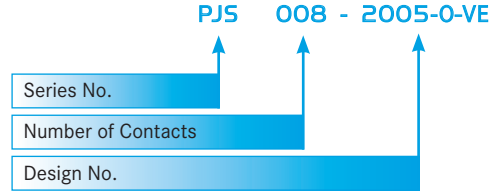

AUTOMOTIVE COMPLIANT

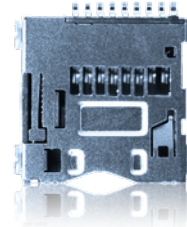

CARD INSERTION DETAILS

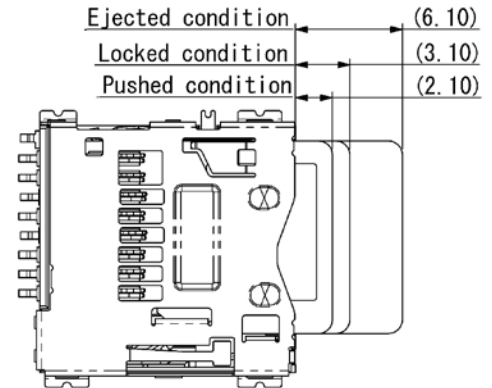

PCB LAYOUT

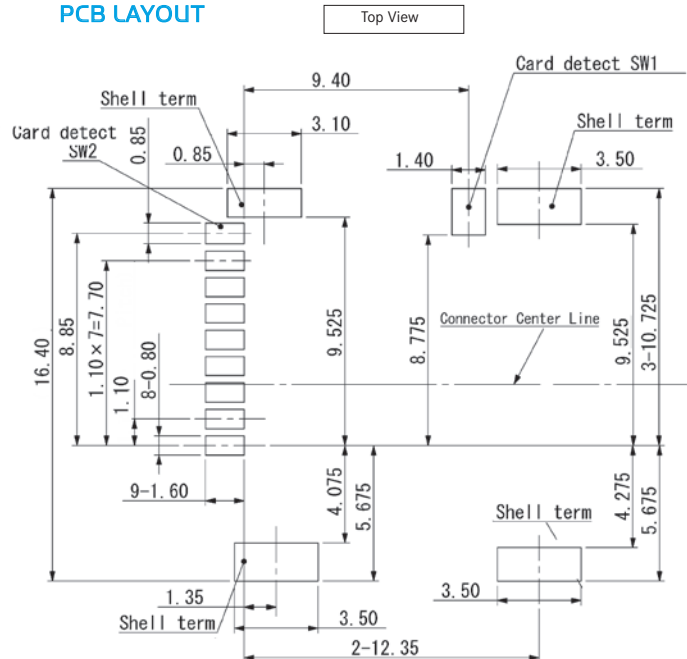

SPECIFICATIONS

Insulation Resistance:	1,000MΩ min. at 500V DC
Withstanding Voltage:	500V AC rms for 1 minute
Contact Resistance:	100mΩ at 1mA / 20mV max.
Voltage Rating:	5.0Vrms AC
Current Rating:	0.5A
Operating Temp. Range:	-25°C to +85°C
Coplanarity:	≤ 0.1mm
Reflow Temp.:	220°C for max.60 secs., 260° peak / 10 secs.
Mating Cycles:	30 times

PART NUMBER

PJS 008 - 4100 - 0-VE

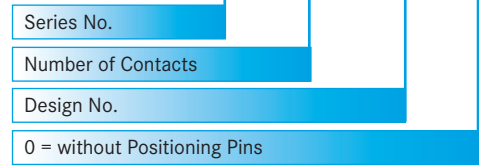

MATERIALS AND FINISH

Insulator:	LCP
Shielding Plate:	Stainless
Contacts:	Copper Alloy, Ni-Au

FEATURES

- Two-point contact on all contacts
- Inner spring coil ensures card position also in vibration and shock conditions
- Metall shell for EMI protection
- RoHS2011/65/EU

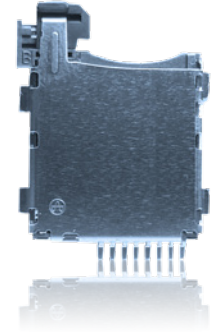

OUTLINE DIMENSIONS

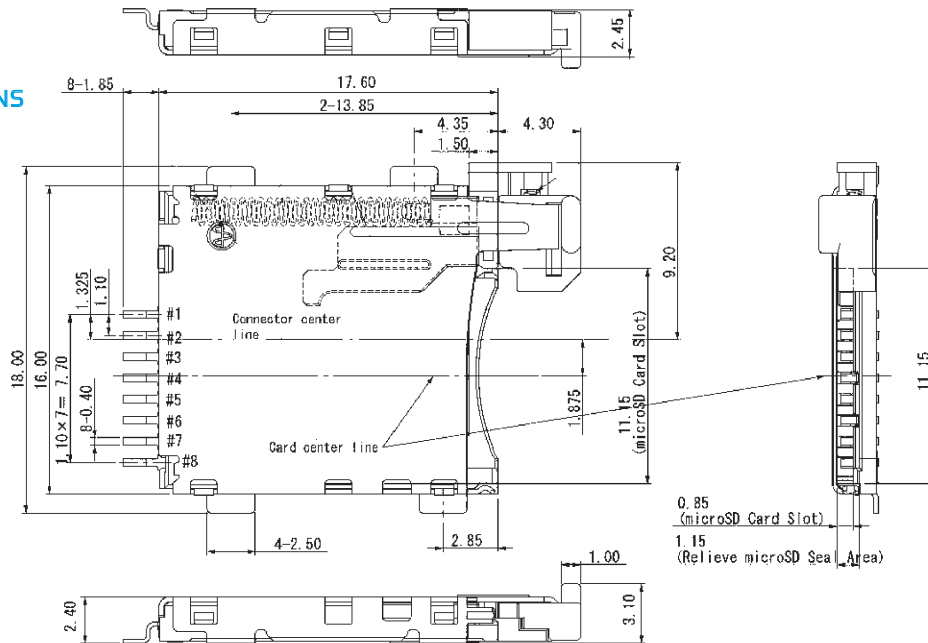

RECOMMENDED PCB LAYOUT

- Prohibited Area
- Button Support Area

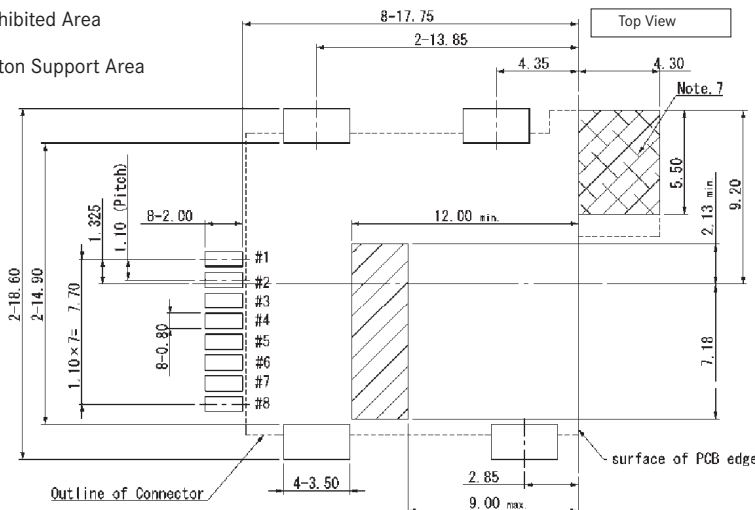

CARD INSERTION DETAILS

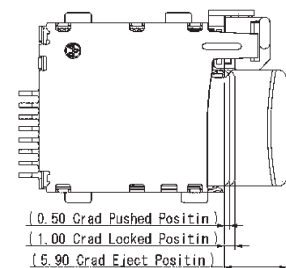

SPECIFICATIONS

Insulation Resistance:	1,000MΩ min. at 250V DC
Withstanding Voltage:	250V AC rms for 1 minute
Contact Resistance:	100mΩ at 1mA / 20mV max.
Voltage Rating:	50Vrms AC
Current Rating:	0.5A
Operating Temp. Range:	-25°C to +85°C
Mating Cycles:	10,000 times, insertion / extraction

MATERIALS AND FINISH

Insulator:	LCP
DIP Terminals:	Brass, Plating Ni / Tin
Contacts:	PB, Plating Ni-Au / Tin

FEATURES

- Vertical insertion
- Small board space
- Robust dip soldering terminal
- Sequential mating / unmating contacts
- RoHS2011/65/EU

OUTLINE DIMENSIONS FOR PJS008U-3000-O

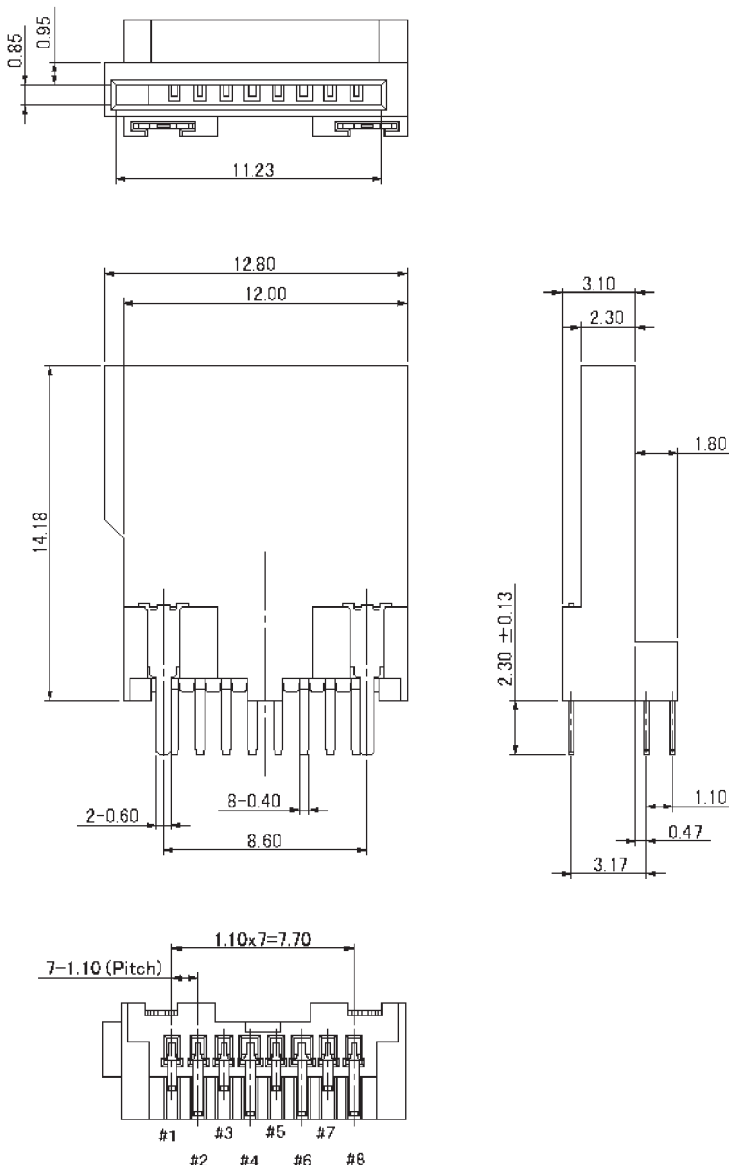

PART NUMBER

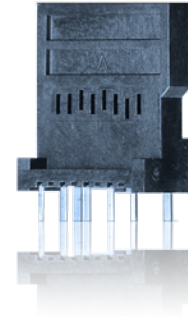
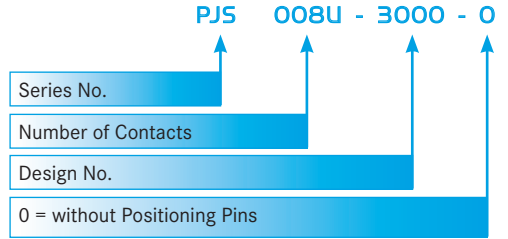

RECOMMENDED PCB LAYOUT

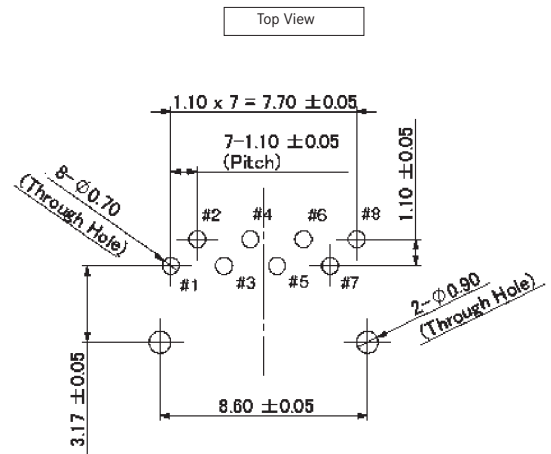

CARD INSERTION DETAILS

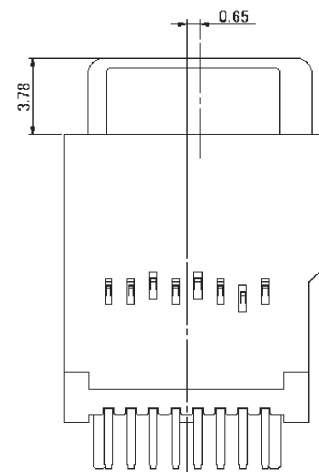

SPECIFICATIONS

Insulation Resistance:	500MΩ min. at 500V DC
Withstanding Voltage:	250V ACrms for 1 minute
Contact Resistance:	100mΩ max. at 10mA / 20mV max.
Current Rating:	0.5A
Voltage Rating:	5.0Vrms
Operating Temp. Range:	-55°C to +85°C
Mating Cycles:	5,000 insertions

MATERIALS AND FINISH

Insulator:	LCP
Contact Plating:	Copper Alloy
	Contact Area: Ni-Au
	Solder Tail: Ni-Au

FEATURES

- Conforms to GSM11.11 standard for the European mobile phone system
- With extra locking mechanism to secure the SIM card inside the connector during shock and vibration
- Smooth extraction function by Push / Lock mechanism
- With switch
- Top Mount Type
- Tape and Reel packaging (500 pcs./reel)
- RoHS2011/65/EU

PART NUMBER

FMS006 - 2610 - 0

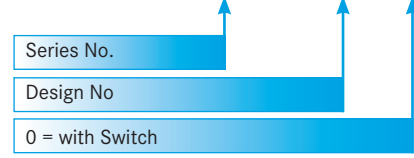

AUTOMOTIVE COMPLIANT



OUTLINE CONNECTOR DIMENSIONS

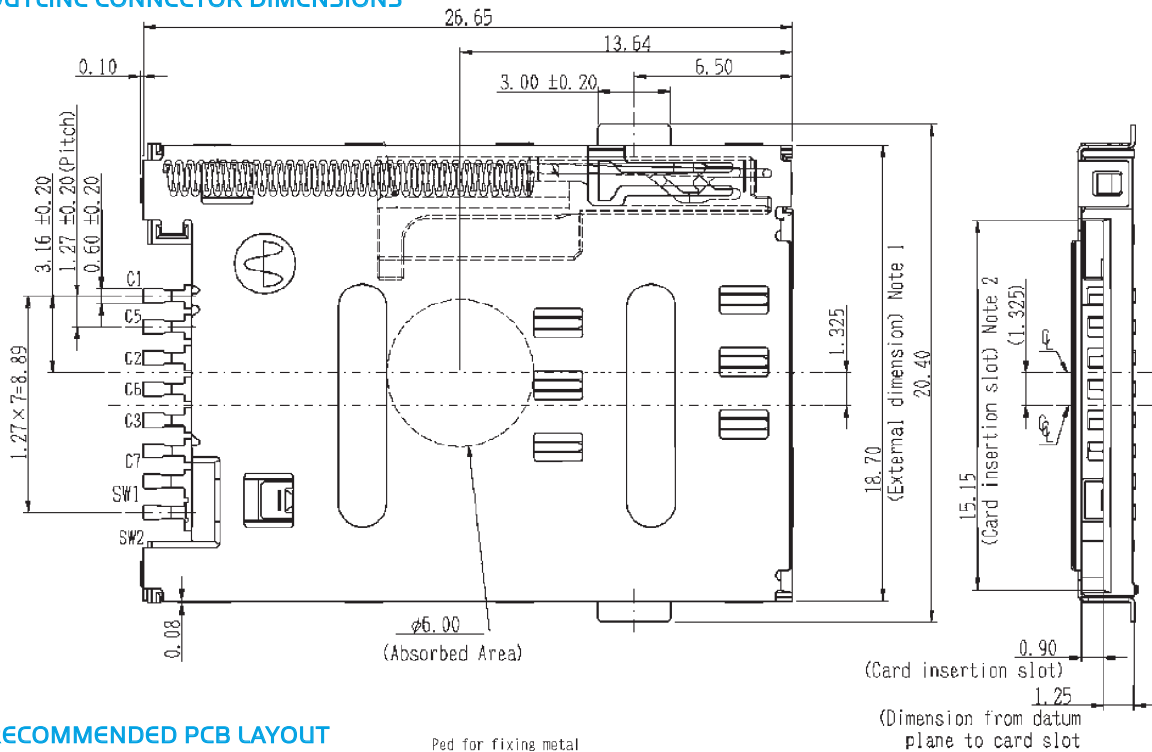

RECOMMENDED PCB LAYOUT

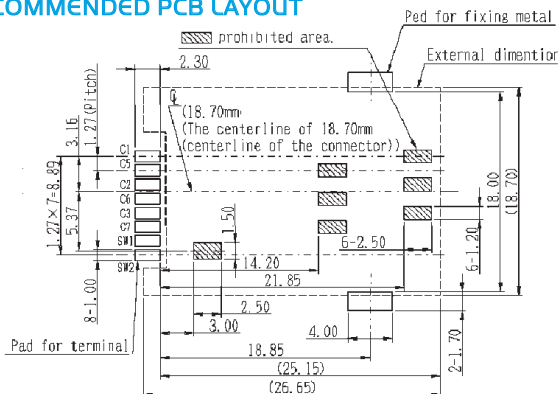

SPECIFICATIONS

Insulation Resistance:	500MΩ min. at 500V DC
Withstanding Voltage:	250V ACrms for 1 minute
Contact Resistance:	100mΩ max. at 1mA / 20mV max.
Current Rating:	0.5A
Voltage Rating:	5.0Vrms
Operating Temp. Range:	-55°C to +85°C
Mating Cycles:	5,000 insertions

MATERIALS AND FINISH

Insulator:	LCP
Contact Plating:	Copper Alloy
Contact Area:	Ni-Au

FEATURES

- Conforms to GSM11.11 standard for the European mobile phone system
- Without switch
- Smooth extraction function by Push / Push mechanism
- Tape and Reel packaging (800 pcs./reel)
- RoHS2011/65/EU

PART NUMBER

FMS006 - 2620 - 0

Series No.	FMS006
Design No.	2620 - 0



OUTLINE CONNECTOR DIMENSIONS

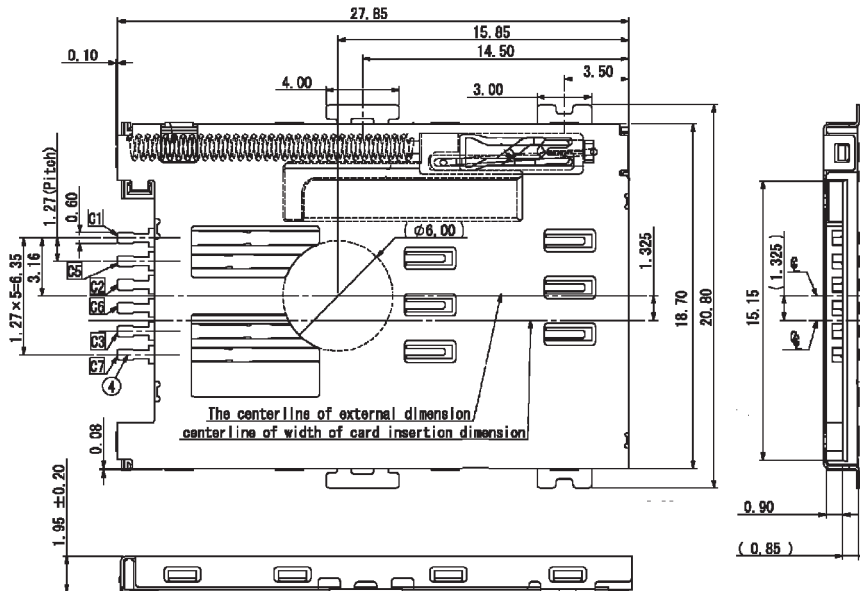

RECOMMENDED PCB LAYOUT (MOUNTING SIDE)

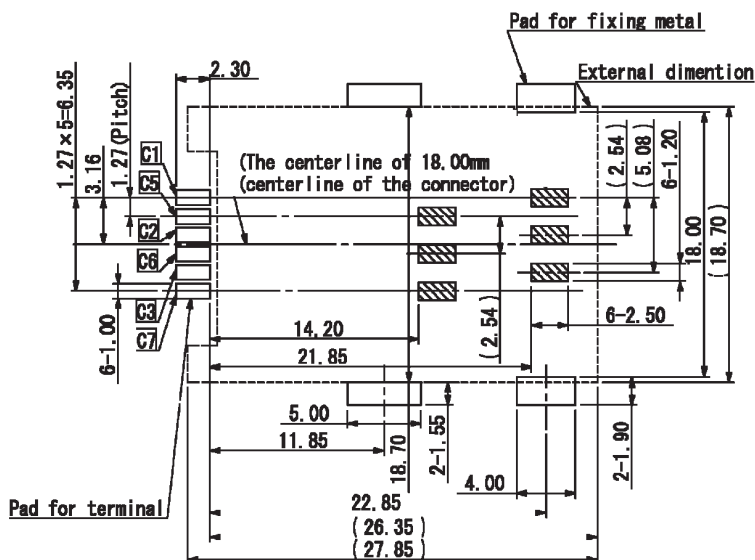

CARD INSERTION

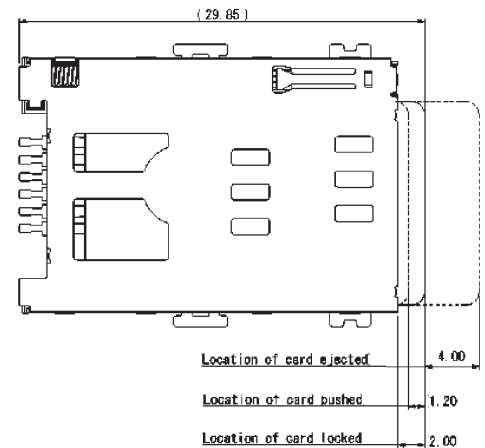

SPECIFICATIONS

Insulation Resistance:	500MΩ min. at 500V DC
Withstanding Voltage:	250V ACrms for 1 minute
Contact Resistance:	100mΩ max. at 10mA / 20mV max.
Current Rating:	0.5A
Voltage Rating:	5.0V AC rms
Operating Temp. Range:	-25°C to +85°C
Mating Cycles:	5,000 insertions

MATERIALS AND FINISH

Insulator	LCP
Shielding plate:	Stainless
Contact:	Copper Alloy, Ni-Au

FEATURES

- Manual type
- Static discontinuity prevention
- Tape and Reel (1,300 pcs./reel)
- Top mount
- Super low profile design ht. = 1.40mm
- RoHS2011/65/EU

PART NUMBER

FMS006 - 5100 - 0

Series No.	↑
Design No.	↑

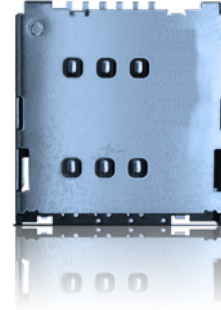

OUTLINE CONNECTOR DIMENSIONS (TOP VIEW)

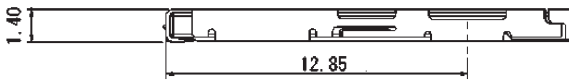
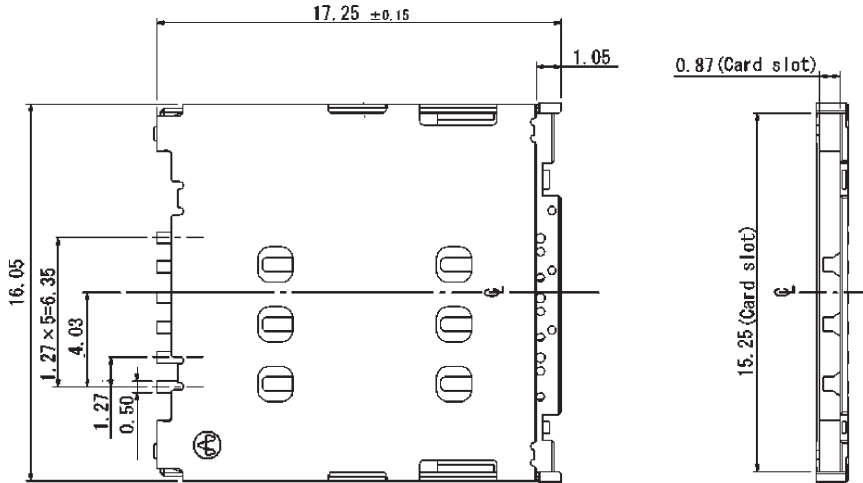

CARD INSERTION

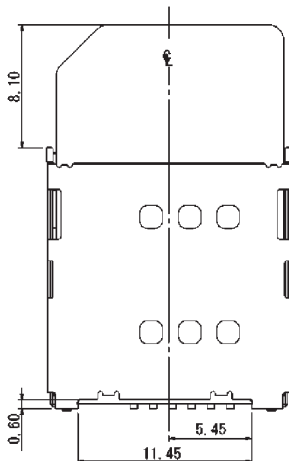

RECOMMENDED PCB LAYOUT

(mounting side)

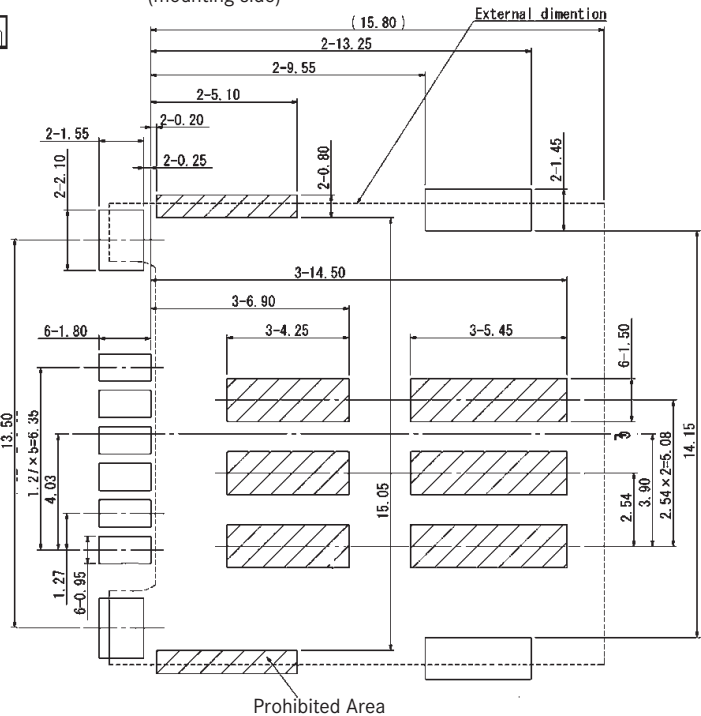

SPECIFICATIONS

Insulation Resistance:	500MΩ min. at 500V DC
Withstanding Voltage:	250V ACrms for 1 minute
Contact Resistance:	100mΩ max. at 10mA / 20mV max.
Current Rating:	0.5A
Voltage Rating:	5.0Vrms
Operating Temp. Range:	-55°C to +85°C
Mating Cycles:	5,000 insertions

PART NUMBER

FMS006 - 2340 - 0 - VE



MATERIALS AND FINISH

Insulator:	LCP
Contact:	Copper Alloy, Ni-Au

AUTOMOTIVE COMPLIANT



FEATURES

- Conforms to GSM11.11 standard for the European mobile phone system
- With extra locking mechanism to secure the SIM card inside the connector during shock and vibration
- Smooth extraction function by Push / Lock mechanism
- For assembly on top of the PC-Board
- With switch
- Tape and Reel packaging (500 pcs./reel)
- RoHS2011/65/EU

OUTLINE CONNECTOR DIMENSIONS

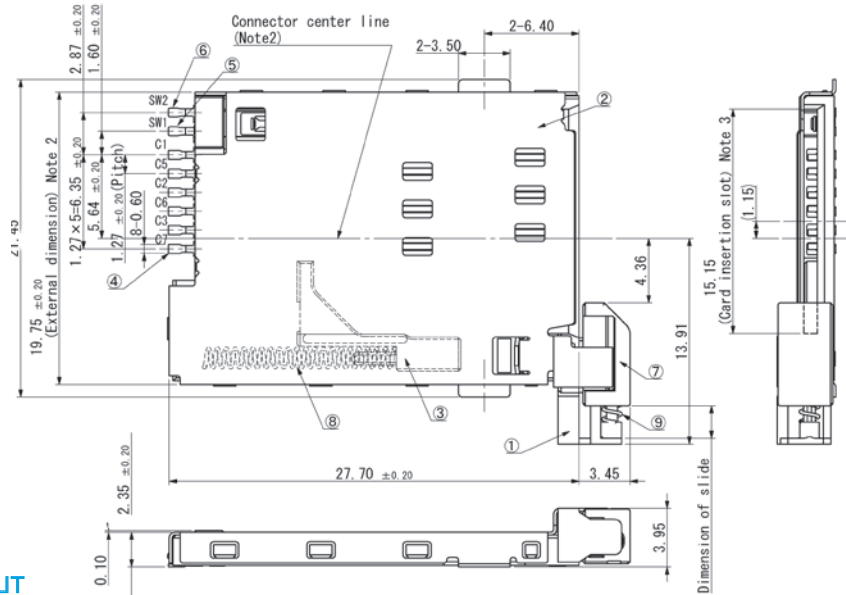

RECOMMENDED PCB LAYOUT (MOUNTING SIDE)

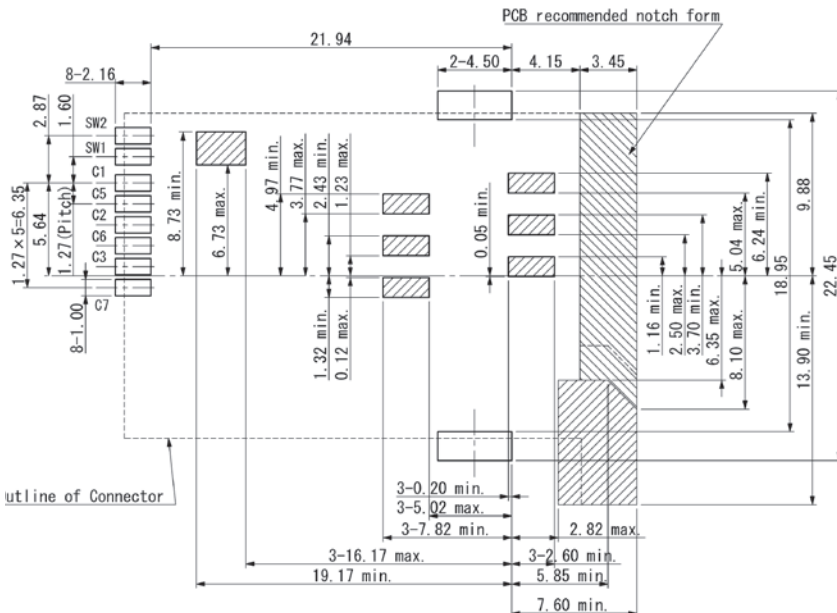

CARD INSERTION

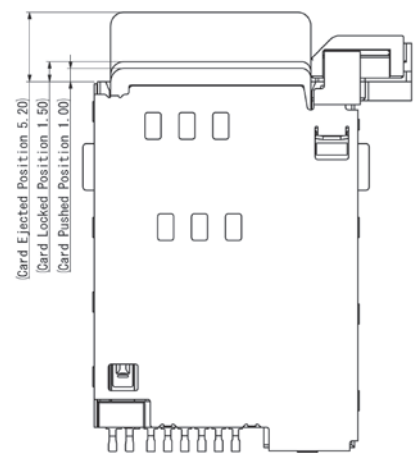

SPECIFICATIONS

Insulation Resistance:	500MΩ min. at 500V DC
Withstanding Voltage:	250V ACrms for 1 minute
Contact Resistance:	100mΩ max. at 10mA / 20mV max.
Current Rating:	0.5A
Voltage Rating:	5.0Vrms
Operating Temp. Range:	-55°C to +85°C
Mating Cycles:	5,000 insertions

MATERIALS AND FINISH

Insulator:	LCP
Contact:	Copper Alloy, Ni-Au

FEATURES

- Conforms to GSM11.11 standard for the European mobile phone system
- With extra locking mechanism to secure the SIM card inside the connector during shock and vibration
- Smooth extraction function by Push / Lock mechanism
- RoHS2011/65/EU

PART NUMBER

FMS006 - 2341 - 0 - VE



AUTOMOTIVE COMPLIANT



- Without switch
- For assembly on top of the PC-Board
- Tape and Reel packaging (500 pcs./reel)

OUTLINE CONNECTOR DIMENSIONS

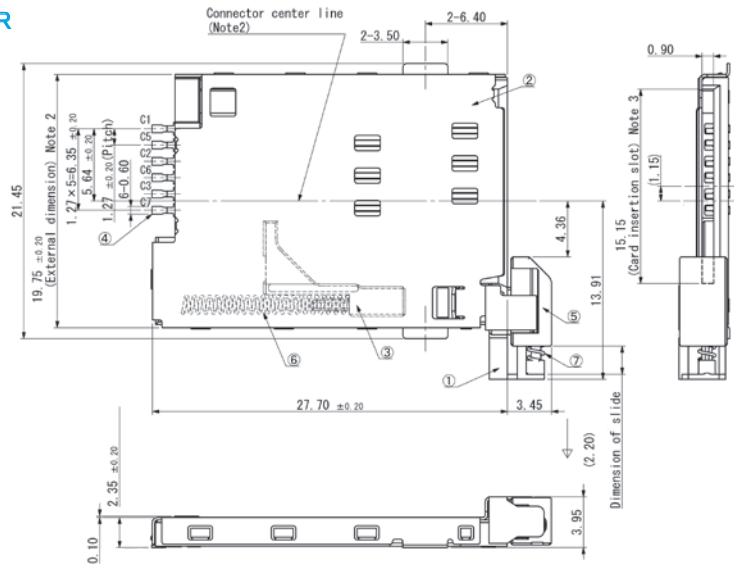

RECOMMENDED PCB LAYOUT (MOUNTING SIDE)

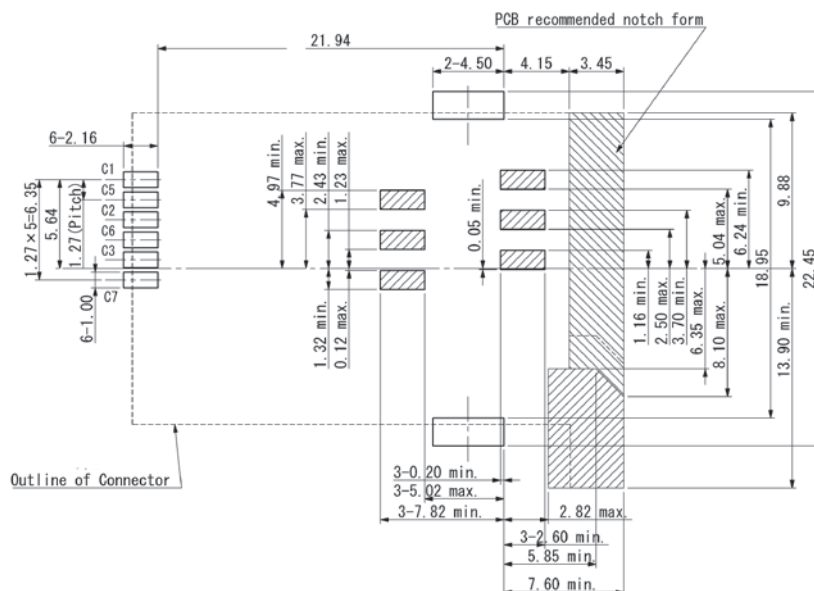

CARD INSERTION

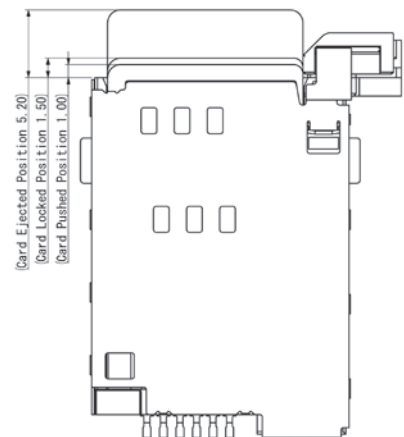

SPECIFICATIONS

Insulation Resistance:	500MΩ min. at 500V DC
Withstanding Voltage:	250V ACrms for 1 minute
Contact Resistance:	100mΩ max. at 1mA / 20mV max.
Current Rating:	0.5A
Voltage Rating:	5V AC rms
Operating Temp. Range:	-25°C to +85°C
Mating Cycles:	5,000 insertions

MATERIALS AND FINISH

Insulator	LCP
Shielding plate:	Stainless
Contact:	Copper Alloy, Ni-Au

FEATURES

- Low profile 1.65mm
- Removable Tray
- Packaging Card Reader: Tape and Reel (1,200 pcs./Tape & Reel)
- Packaging for Trays: Tray (400 pcs.)
- RoHS2011/65/EU

PART NUMBER

FMS006 - 3710 - 0



PART NUMBER TRAY

FMA006-3700 - 0

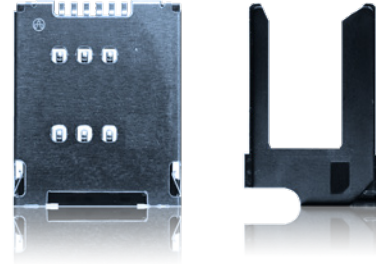

OUTLINE CONNECTOR DIMENSIONS (TOP VIEW)

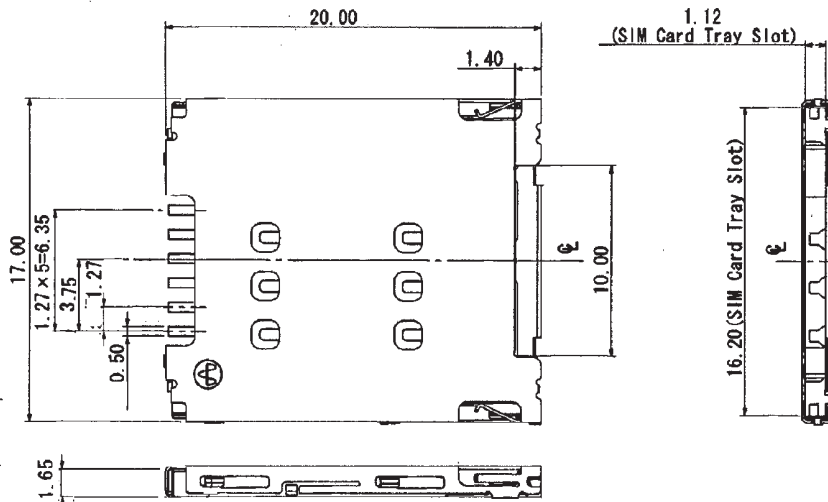

RECOMMENDED PCB LAYOUT (MOUNTING SIDE)

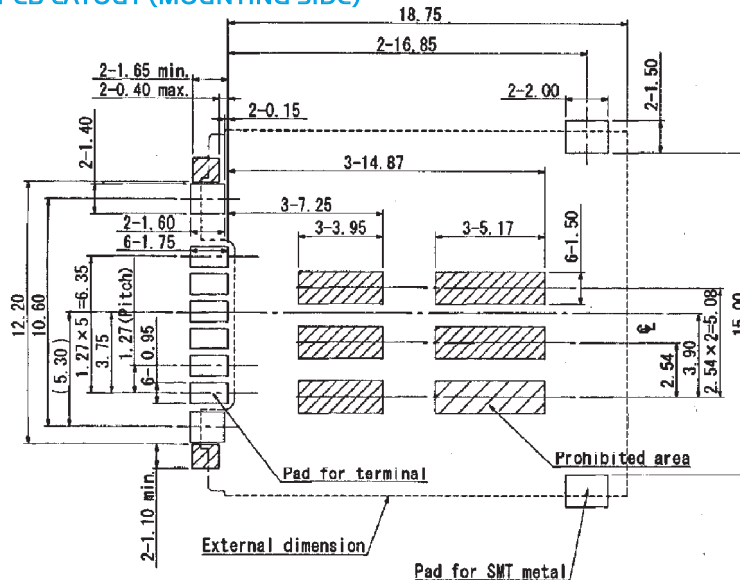

SPECIFICATIONS

Insulation Resistance:	500MΩ min. at 500V DC
Withstanding Voltage:	250V ACrms for 1 minute
Contact Resistance:	100mΩ max. at 1mA / 20mV max.
Current Rating:	0.5A
Voltage Rating:	5V AC rms
Operating Temp. Range:	-25°C to +85°C
Mating Cycles:	5,000 insertions

MATERIALS AND FINISH

Insulator	LCP
Shielding plate:	Stainless
Contact:	Copper Alloy, Ni-Au

FEATURES

- Low profile 1.65mm
- Removeable Tray
- Packaging Card Reader: Tape and Reel (1,200 pcs./Tape & Reel)
- Packaging for Trays: Tray (400 pcs.)
- RoHS2011/65/EU

PART NUMBER

FMS006 - 3810 - 0



PART NUMBER TRAY

FMA006-3800-0

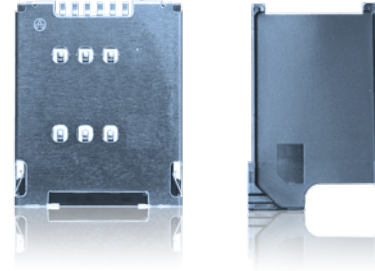

OUTLINE CONNECTOR DIMENSIONS (TOP VIEW)

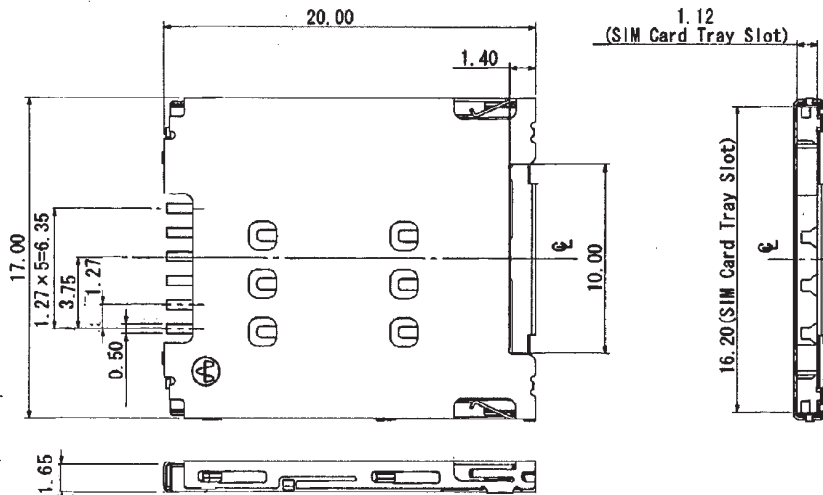

RECOMMENDED PCB LAYOUT (MOUNTING SIDE)

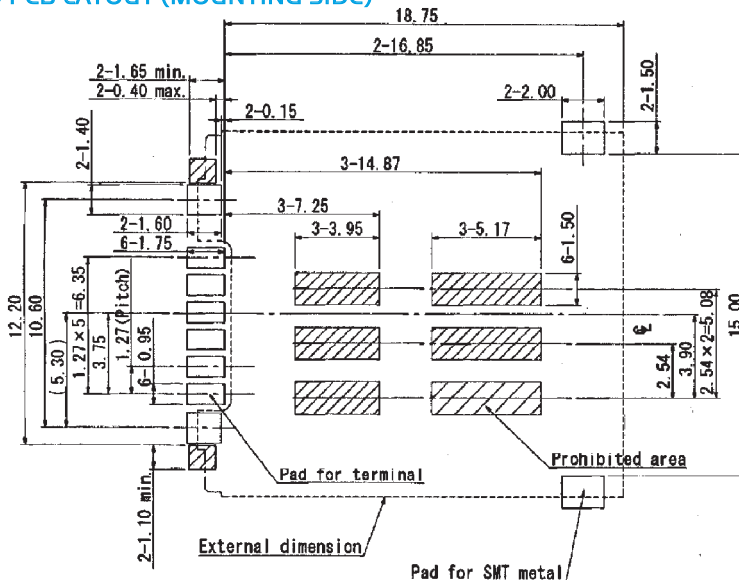

SPECIFICATIONS

Insulation Resistance:	500MΩ min.
Withstanding Voltage:	250V ACrms for 1 minute
Contact Resistance:	100mΩ max. at 1mA/20mV max.
Current Rating:	0.5A
Voltage Rating:	5.0Vrms
Operating Temp. Range:	-25°C to +85°C
Mating Cycles:	5,000 insertions

MATERIALS AND FINISH

Insulator:	LCP
Contact :	Copper Alloy, t = 0.12, Ni-Au

AUTOMOTIVE COMPLIANT



FEATURES

- Reversed mount type
- One card reader usable with two different trays for Nano or Micro Sim Cards
- Super low profile 1.15mm height
- RoHS2011/65/EU

PART NUMBER (WITHOUT TRAY)
FUS006 - 3210-0



PART NUMBER TRAY TYPE FOR MICROSIM
FUA006 - 3210-0



PART NUMBER TRAY TYPE FOR NANOSIM
FUA006 - 3220-0

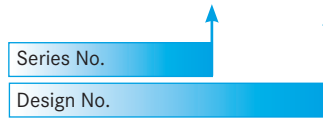

OUTLINE CONNECTOR DIMENSIONS

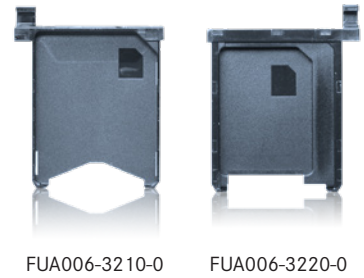
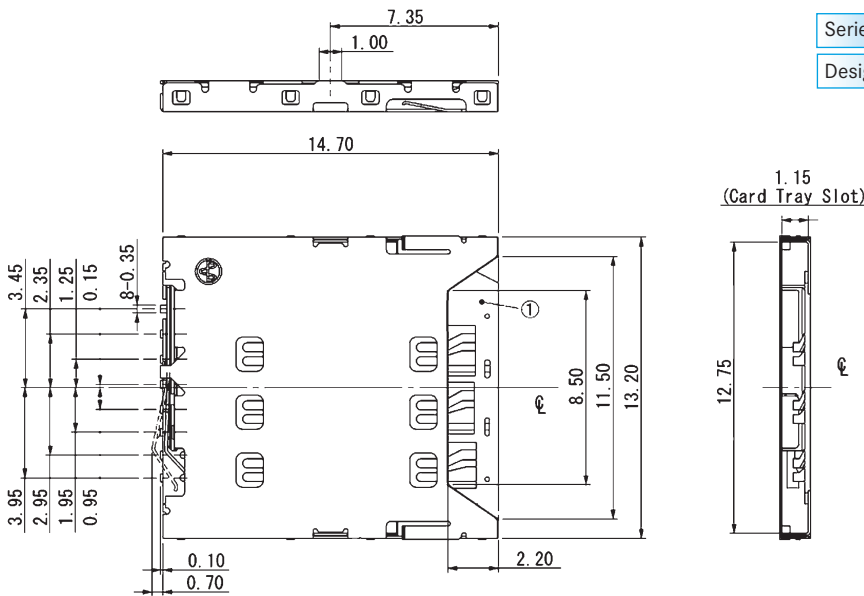

TRAY FOR MICROSIM

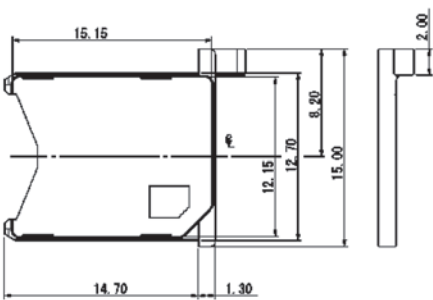

RECOMMENDED PCB LAYOUT

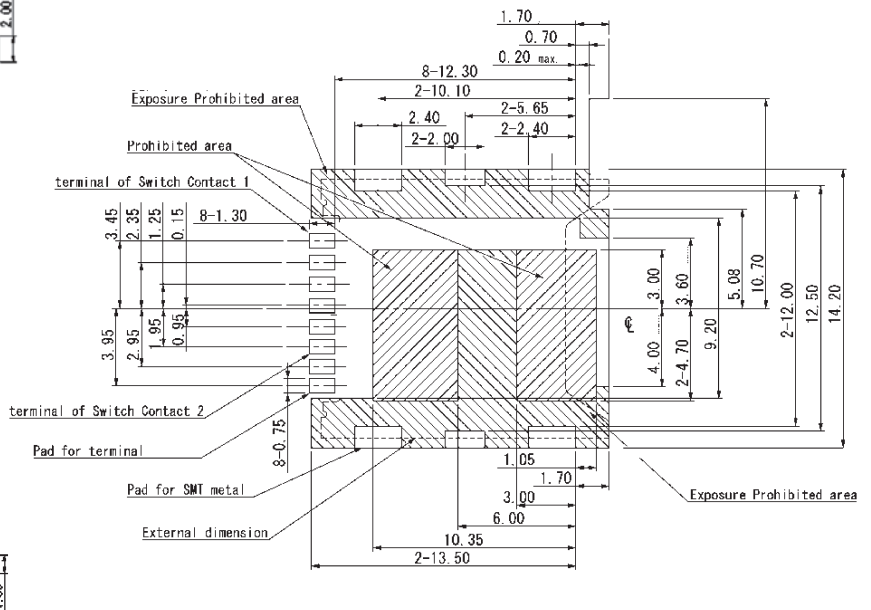

TRAY FOR NANOSIM

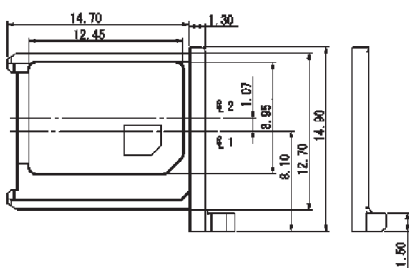

SPECIFICATIONS

Insulation Resistance:	1000MΩ at 500V DC
Withstanding Voltage:	500Vrms
Current Rating:	1A AC/DC max.
Contact Resistance:	40mΩ max. at 20mV max.
Operating Temp. Range:	-55°C to +85°C
Reflow Solder Temp.:	220°C min. / 60 sec., 260°C peak
Mating Cycles:	10,000 times

MATERIALS AND FINISH

Insulator:	Thermal Plastic (UL94V-0)
Shell:	Steel
Contacts:	Copper Alloy
Plating:	Underplate - 50μ" ~ 100μ" Nickel Contact Area - Gold 15μ" selective Gold Solder Tails - T = 100μ" ~ 200μ" Tin

FEATURES

- Fast Type
- With or without Stand-off
- With or without Ejector
- RoHS2011/65/EU

OUTLINE DIMENSIONS

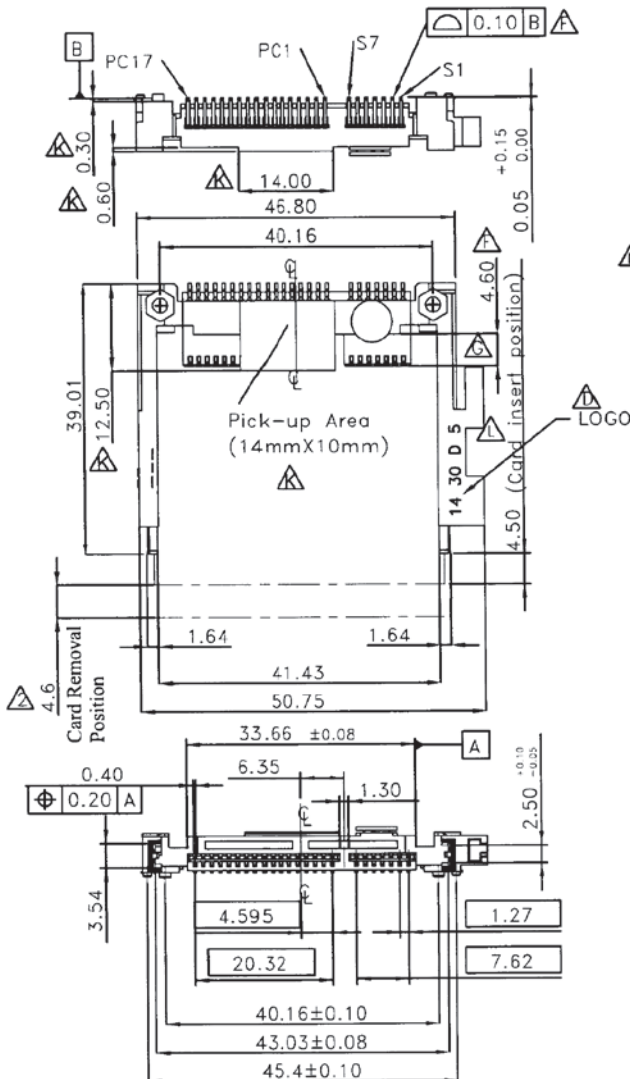

PART NUMBER

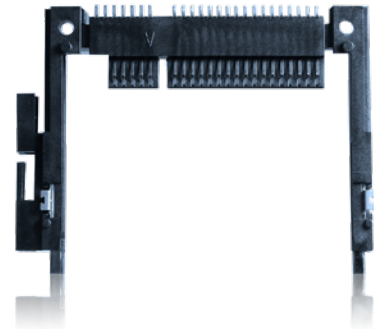
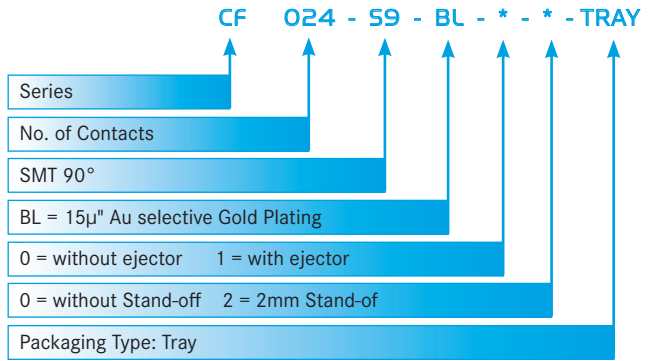

RECOMMENDED PCB LAYOUT

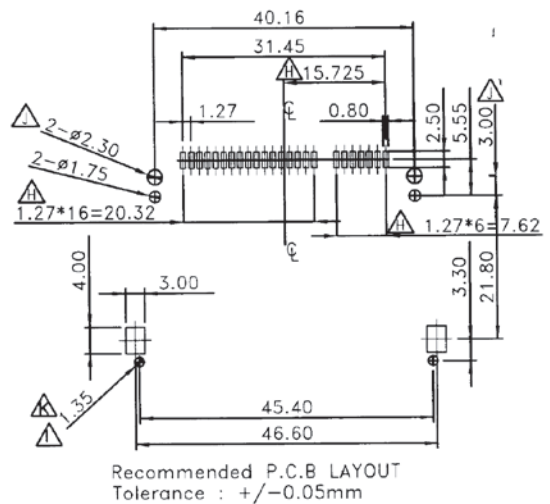

SPECIFICATIONS

Insulation Resistance:	1000MΩ at 500V DC
Withstanding Voltage:	500Vrms
Current Rating:	0.5A
Operating Temp. Range:	-20°C to +90°C
Reflow Solder Temp.:	220°C min./sec. 260°C peak
Mating Cycles:	10,000 times

MATERIALS AND FINISH

Insulator:	LCP, glass filled (UL94V-0)
SMT Metal:	Brass, pure Sn
Push Button:	Glass reinforced PBT (UL94V-0)
Cover:	Stainless Steel
Contacts:	Brass
Plating:	Contacts - Gold (15μ") over Nickel (40μ") Solder Tails - pure Sn

FEATURES

- Adapter for Compact Flash Card Type I
- With push button ejector (optional)
- RoHS2011/65/EU

OUTLINE DIMENSIONS (WITHOUT EJECTOR)

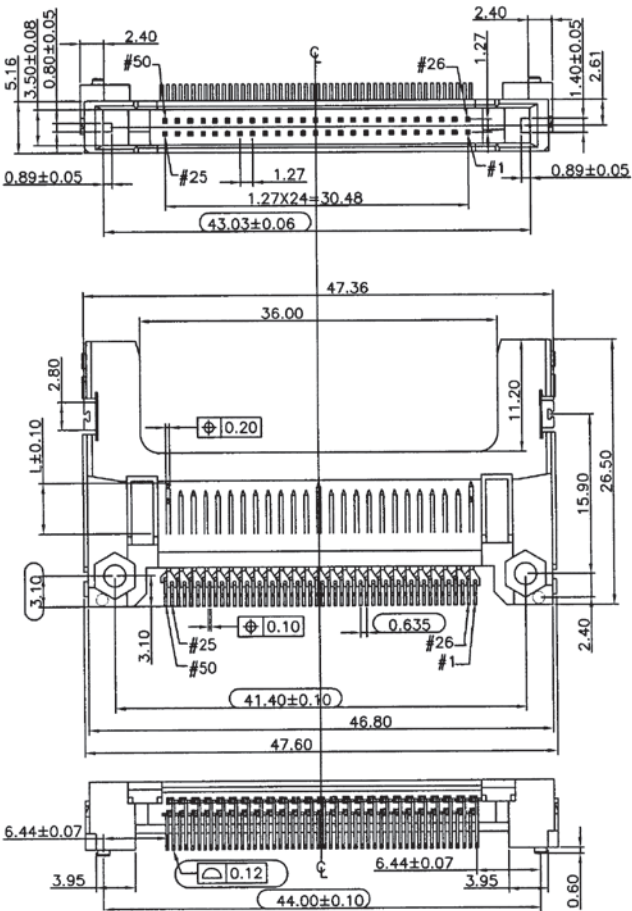

PART NUMBER

CF 050P - 003 - * * DS

Series	CF
No. of Contacts	050P
90° SMT	003
Ejector: 0 = Without 1 = Right Side	*
Insulator Colour: 0 = White (standard) 1 = Black (on request only)	*
Plating Area: Contacts: Gold (15μ") over 40μ" Nickel Solder Tails: 100μ" Tin over 40μ" Nickels	DS

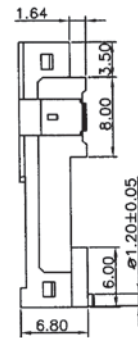
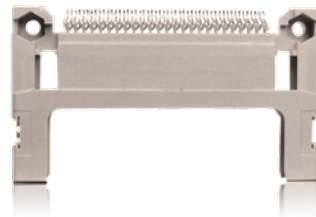

RECOMMENDED PCB LAYOUT AND MOUNTING AREA

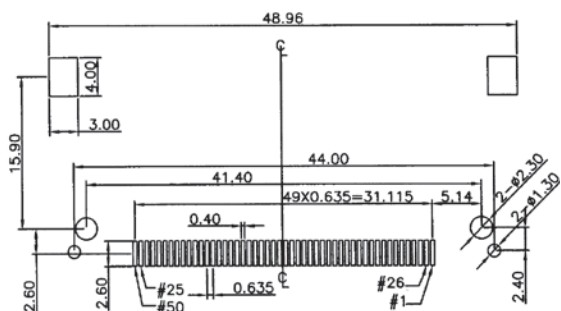

SPECIFICATIONS

Insulation Resistance:	1000MΩ at 500V DC
Withstanding Voltage:	500Vrms
Current Rating:	0.5A
Operating Temp. Range:	-55°C to +85°C
Reflow Solder Temp.:	220°C min. / 60 sec, 260°C peak
Mating Cycles:	10,000 times

MATERIALS AND FINISH

Insulator:	LCP, glass filled (UL94V-0)
SMT Metal:	Brass, pure Sn
Push Button:	Glass reinforced PBT (UL94V-0)
Cover:	Stainless Steel
Contacts:	Brass
Plating:	Contacts - Gold (15μ") over Nickel (40μ") Solder Tails - pure Sn

PART NUMBER

CF 050 P2 - * 0 3 - * 0 - DS 3

Series	CF
No. of Contacts	050
Stand-off Height: 0 = without 1 = 2.20mm	P2 - * 0
0 = Top Mounted on PCB	3
3 = 90° SMT	- * 0
Ejector: 0 = Without 1 = Right Side	- DS 3
Plating Area:	
Contacts: Gold (15μ") over 40μ" Nickel	
Solder Tails: 100μ" Tin over 40μ" Nickel	
No Mark = Without Foil	
3 = Mylar Foil	

FEATURES

- Adapter for Compact Flash Card Type I and II
- With push button ejector (optional)
- RoHS2011/65/EU

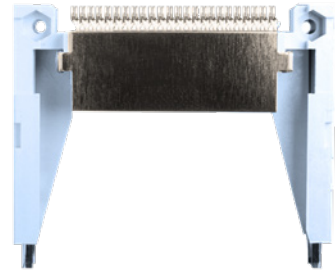

OUTLINE DIMENSIONS (NO STAND-OFF)

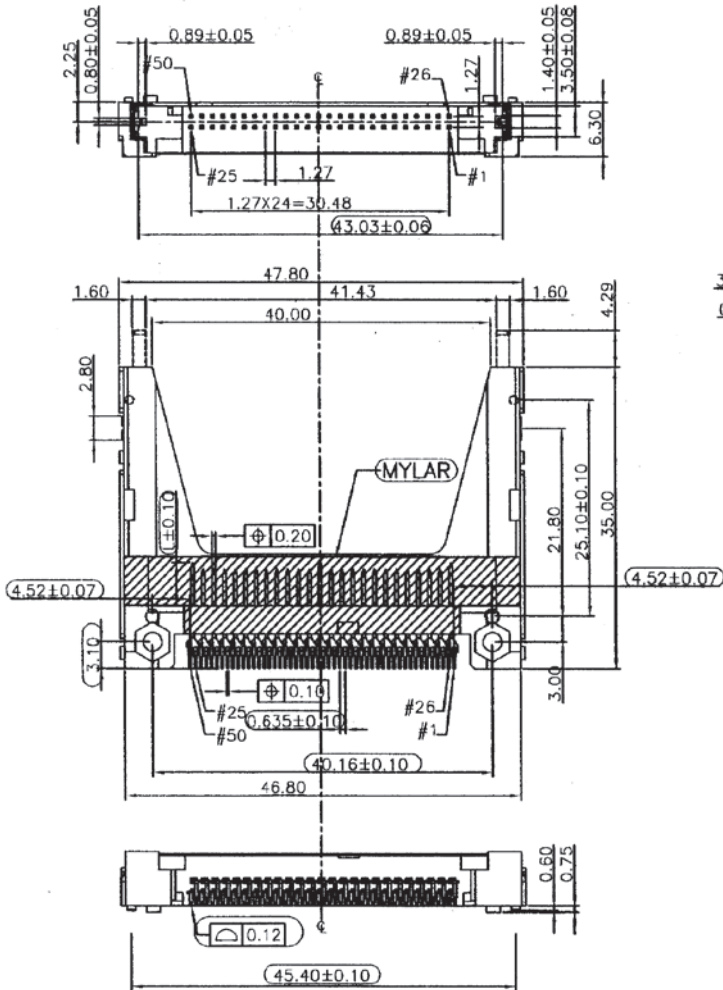

RECOMMENDED PCB LAYOUT

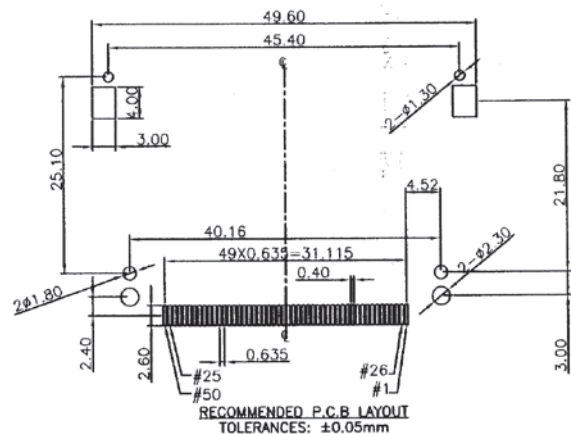

SPECIFICATIONS

Insulation Resistance:	1000MΩ at 500V DC
Withstanding Voltage:	500Vrms
Current Rating:	1A AC/DC max.
Contact Resistance:	40mΩ max. at 20mV max.
Operating Temp. Range:	-55°C to +85°C
Reflow Solder Temp.:	220°C min. / 60 sec, 260°C peak
Mating Cycles:	10,000 times

MATERIALS AND FINISH

Insulator:	LCP, glass filled (UL94V-0)
SMT Metal:	Brass, pure Sn
Push Button:	Glass reinforced PBT (UL94V-0)
Cover:	Stainless Steel
Contacts:	Brass
Plating:	Contacts - Gold (15μ") over Nickel (40μ") Solder Tails - pure Sn

FEATURES

- Adapter for Compact Flash Card type I and II
- Reversed type, for assembly underneath the PCB
- RoHS2011/65/EU

OUTLINE DIMENSIONS

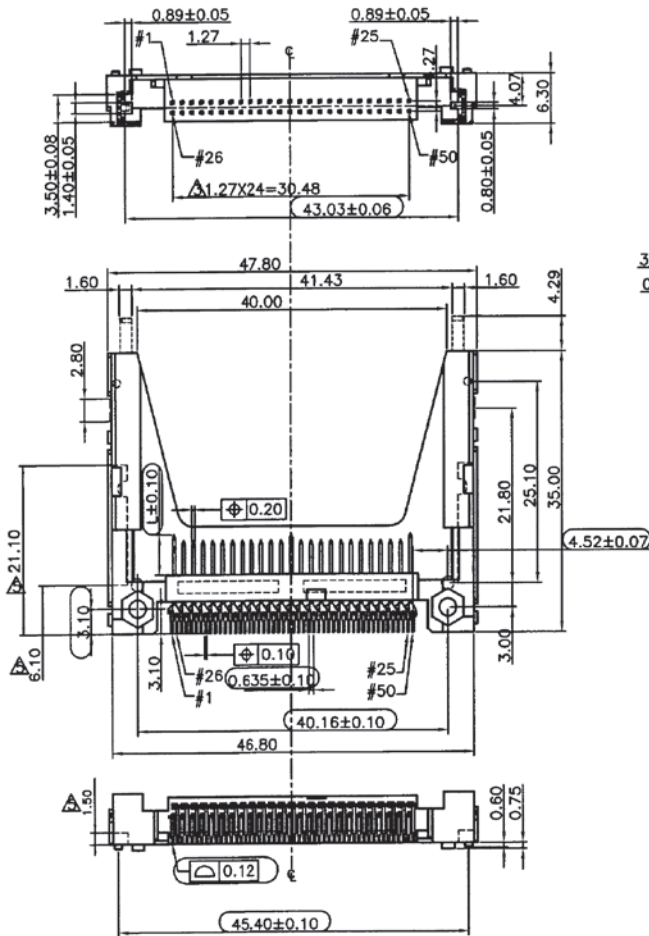

PART NUMBER

CF 050 P2 - 0 1 3 - * 0 DS 3

Series	CF
No. of Contacts	050
Stand-off Height: 0 = without	P2
1 = Bottom Mounted on PCB	0
3 = 90° SMT	1 3
Ejector: 0 = Without 1 = Right Side	- * 0
Plating Area: Contacts: Gold (15μ") over 40μ" Nickel Solder Tails: 100μ" Tin over 40μ" Nickel	DS 3
No Mark = Without Foil 3 = Mylar Foil	



RECOMMENDED PCB LAYOUT

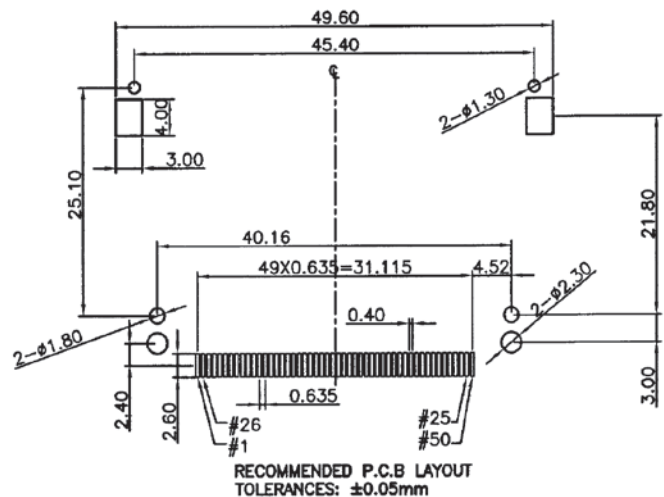

SPECIFICATIONS

Insulation Resistance:	1000MΩ at 500V DC
Withstanding Voltage:	500Vrms
Current Rating:	1A AC/DC max.
Contact Resistance:	40mΩ max. at 20mV max.
Operating Temp. Range:	-55°C to +85°C
Reflow Solder Temp.:	220°C min. / 60 sec., 260°C peak
Mating Cycles:	10,000 times

MATERIALS AND FINISH

Insulator:	LCP, glass filled (UL94V-0)
SMT Metal:	Brass, pure Sn
Contacts:	Brass
Plating:	Contacts - Gold (15μ") over Nickel (40μ") Solder Tails - pure Sn

FEATURES

- Adapter for Compact Flash Card type I and II
- Available for top and bottom PCB mounting
- Without cap for pick and place
- RoHS2011/65/EU

OUTLINE DIMENSIONS

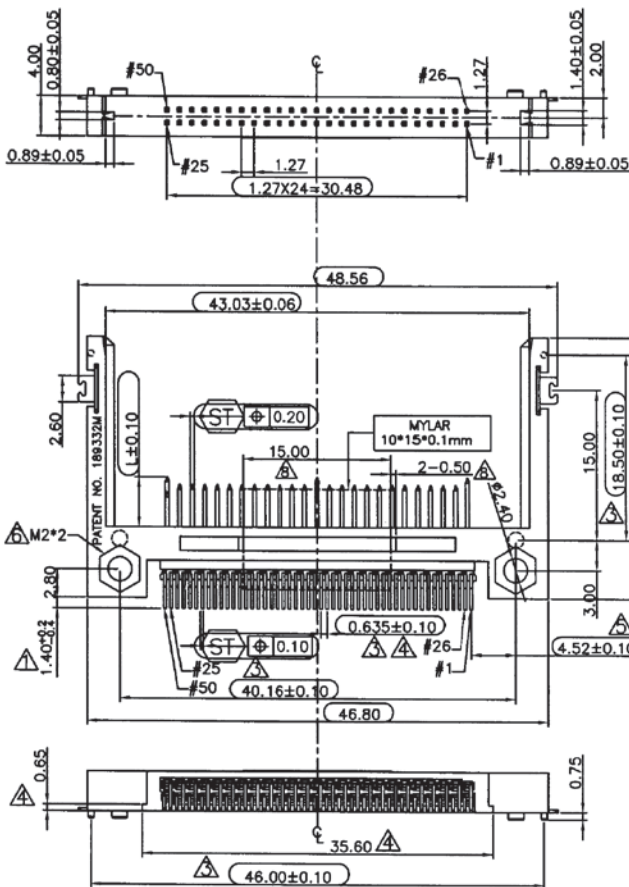

POWER	5.00mm	1,13,38,50
GENERAL	4.25mm	all other pins
DETECT	3.50mm	25,26
Pin type	Interface Dim. L	Pin No.

PART NUMBER

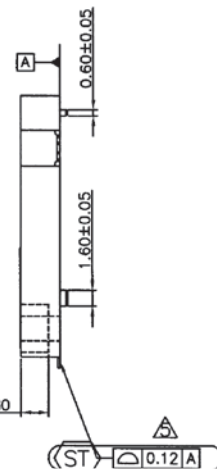
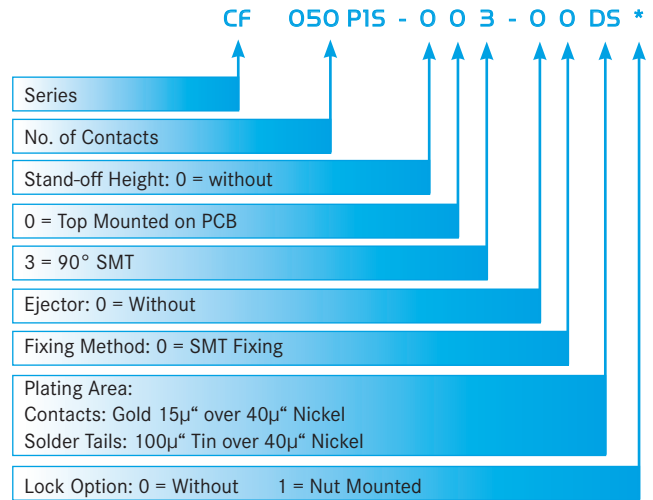

RECOMMENDED PCB LAYOUT

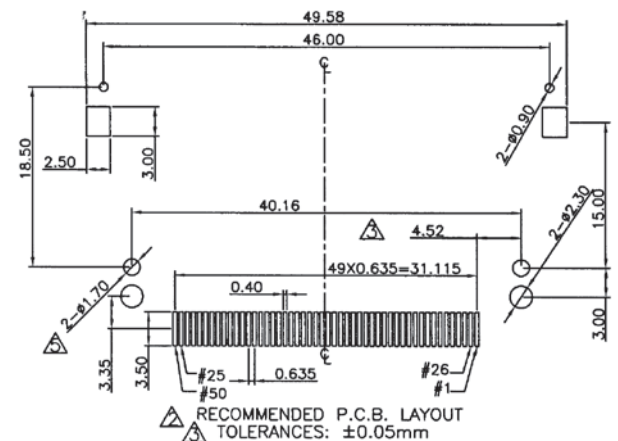

SPECIFICATIONS

Insulation Resistance:	1000MΩ at 500V DC
Withstanding Voltage:	500Vrms
Current Rating:	1A AC/DC max.
Contact Resistance:	40mΩ max. at 20mV max.
Operating Temp. Range:	-55°C to +85°C
Reflow Solder Temp.:	220°C min. / 60 sec., 260°C peak
Mating Cycles:	10,000 times

MATERIALS AND FINISH

Insulator:	LCP, glass filled (UL94V-0)
SMT Metal:	Brass, pure Sn
Contacts:	Brass
Plating:	Contacts - Gold (15μ") over Nickel (40μ") Solder Tails - pure Sn

FEATURES

- Adapter for Compact Flash Card Type I
- Available for top and bottom PCB mounting
- Without cap for pick and place
- RoHS2011/65/EU

PART NUMBER

CF 050 P15 - 0 1 3 - 0 0 DS *

Series	CF
No. of Contacts	050
Stand-off Height: 0 = without	P15
1 = Bottom Reversed on PCB	- 0
3 = 90° SMT	1 3
Ejector: 0 = Without	- 0
Fixing Method: 0 = SMT Fixing	0 0
Plating Area: Contacts: Gold 15μ" over 40μ" Nickel Solder Tails: 100μ" Tin over 40μ" Nickel	DS *
Lock Option: 0 = Without 1 = Nut Mounted	



OUTLINE DIMENSIONS

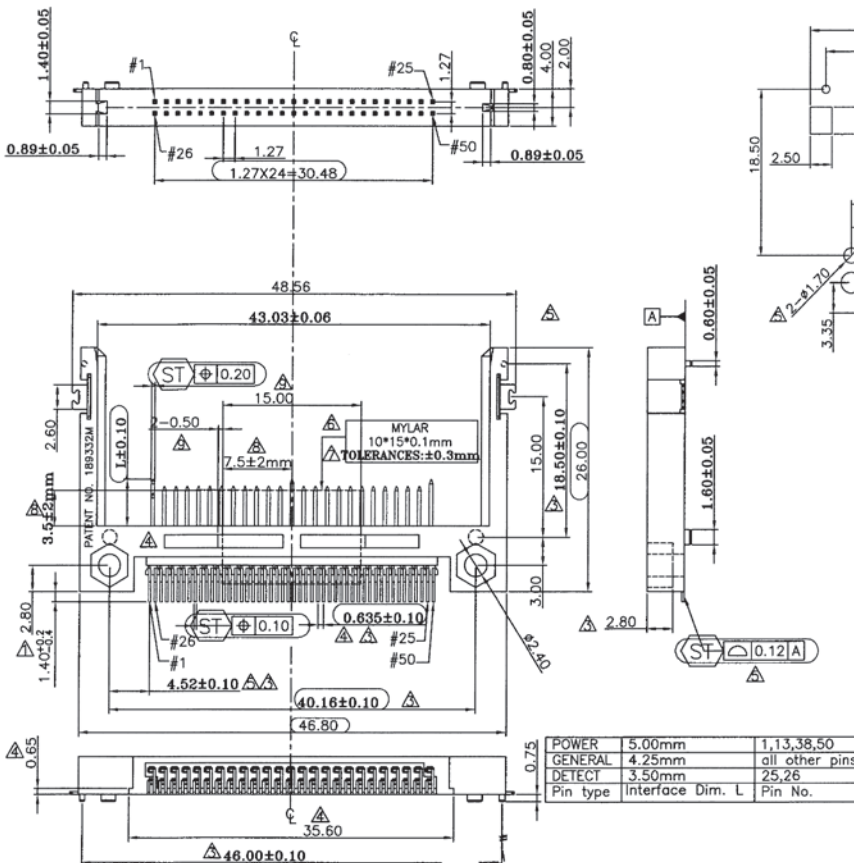

RECOMMENDED PCB LAYOUT

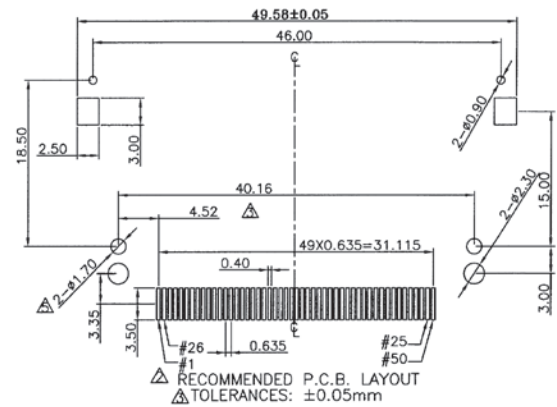

SPECIFICATIONS

Insulation Resistance:	1000MΩ at 500V DC
Withstanding Voltage:	500Vrms
Current Rating:	1A AC/DC max.
Contact Resistance:	40mΩ max. at 20mV max.
Operating Temp. Range:	-55°C to +85°C
Reflow Solder Temp.:	220°C min. / 60 sec, 260°C peak
Mating Cycles:	10,000 times

MATERIALS AND FINISH

Insulator:	LCP, glass filled (UL94V-0)
Push Button:	Glass reinforced PBT (UL94V-0)
SMT Metal:	Brass, pure Sn
Pivot Shell:	Stainless Steel
Contacts:	Brass
Plating:	Contacts - Gold (15μ") over Nickel (40μ") Solder Tails - pure Sn

FEATURES

- Adapter for Compact Flash Card type I and II
- Available with various ejectors and stand-offs
- RoHS2011/65/EU

PART NUMBER

CF 050 P25 - * 0 3 - * 0 DS *

Series	CF
No. of Contacts	050
Stand-off Height 0 = Without 1 = 2.20mm	P25
PCB Mounting Type: 0 = Top	- * 0
90° SMT	3
Ejector: 0 = Without 1 = Right Side (41.3mm) 2 = Left Side (41.3mm) 3 = Right Side (34.7mm) 4 = Left Side (34.7mm)	- * 0 DS *
Fixing Method: 0 = SMT Fixing	
Plating Area: Contacts: Gold 15μ" over 40μ" Nickel Solder Tails: 100μ" Tin over 40μ" Nickel	
Lock Option: 0 = Without 1 = Nut Mounted	



OUTLINE DIMENSIONS (NO STAND-OFF)

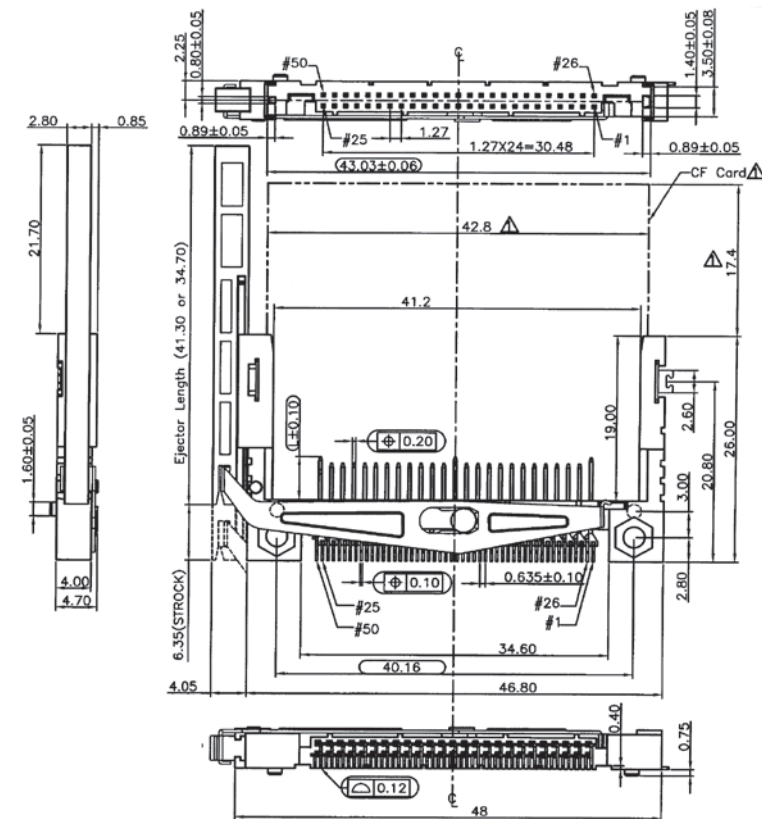

RECOMMENDED PCB LAYOUT

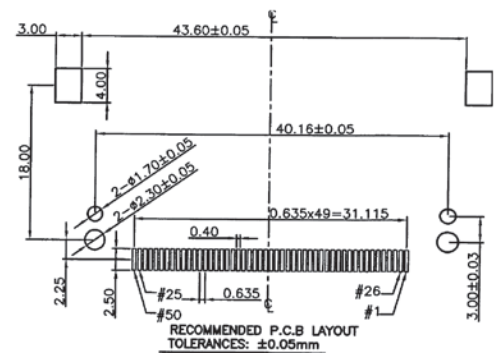

SPECIFICATIONS

Insulation Resistance:	1000MΩ at 500V DC
Withstanding Voltage:	500Vrms
Current Rating:	1A AC/DC max.
Contact Resistance:	40mΩ max. at 20mV max.
Operating Temp. Range:	-55°C to +85°C
Reflow Solder Temp.:	220°C min. / 60 sec, 260°C peak
Mating Cycles:	10,000 times

MATERIALS AND FINISH

Insulator:	LCP, glass filled (UL94V-0)
Push Button:	Glass reinforced PBT (UL94V-0)
SMT Metal:	Brass, pure Sn
Pivot Shell:	Stainless Steel
Contacts:	Brass
Plating:	Contacts - Gold (15μ") over Nickel (40μ") Solder Tails - pure Sn

FEATURES

- Reverse type without stand-off height is not applicable to Compact Flash Card Type II
- Adapter for Compact Flash Card type I and II
- Available with various ejectors
- RoHS2011/65/EU

PART NUMBER

CF 050 P25 - * 1 3 - * 0 DS *

Series	CF
No. of Contacts	050
Stand-off Height 0 = Without 1 = 2.20mm	P25
PCB Mounting Type: 1 = Bottom Reverse	- * 1 3
90° SMT	- * 0 DS
Ejector: 0 = Without 1 = Right Side (41.3mm) 2 = Left Side (41.3mm) 3 = Right Side (34.7mm) 4 = Left Side (34.7mm)	*
Fixing Method: 0 = SMT Fixing	*
Plating Area: Contacts: Gold 15μ" over 40μ" Nickel Solder Tails: 100μ" Tin over 40μ" Nickel	
Lock Option: 0 = Without 1 = Nut Mounted	*

OUTLINE DIMENSIONS (STAND-OFF HEIGHT 2.20MM)

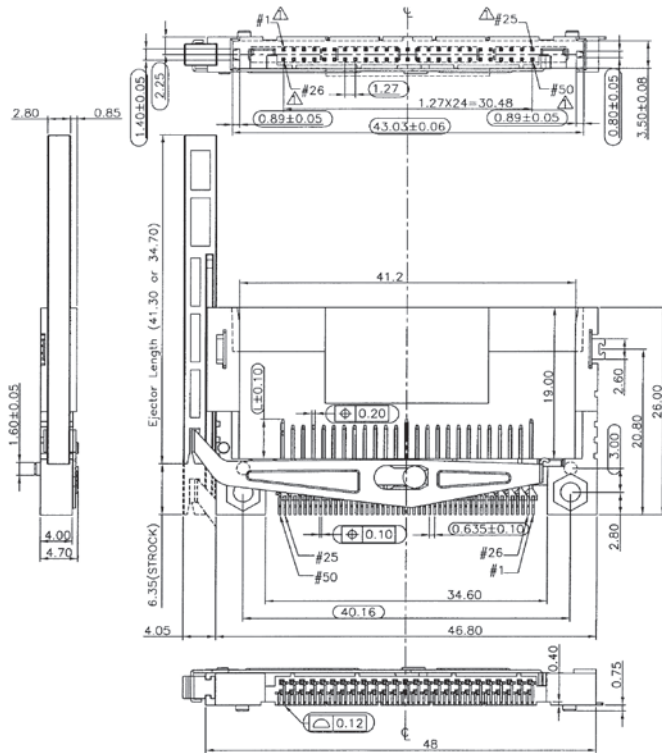

RECOMMENDED PCB LAYOUT

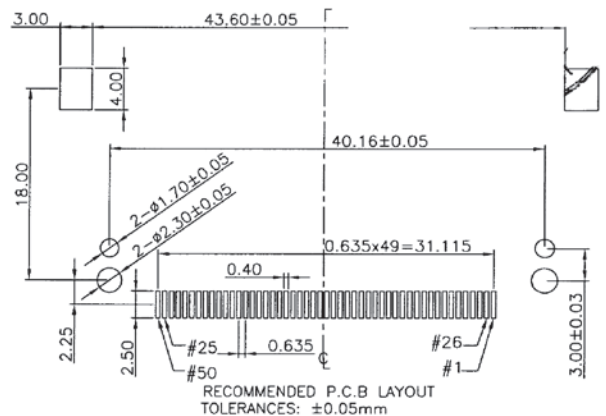

FEATURES

- Locking bow secure the Compact Flash card in the connector
- Locking bow must be used in combination with CF050P2-*03-00-DS connectors
- Locking bow is attached after the CF card is inserted into the connector
- RoHS2011/65/EU

PART NUMBER

CF 050P2-LT REV3.0



OUTLINE DIMENSIONS

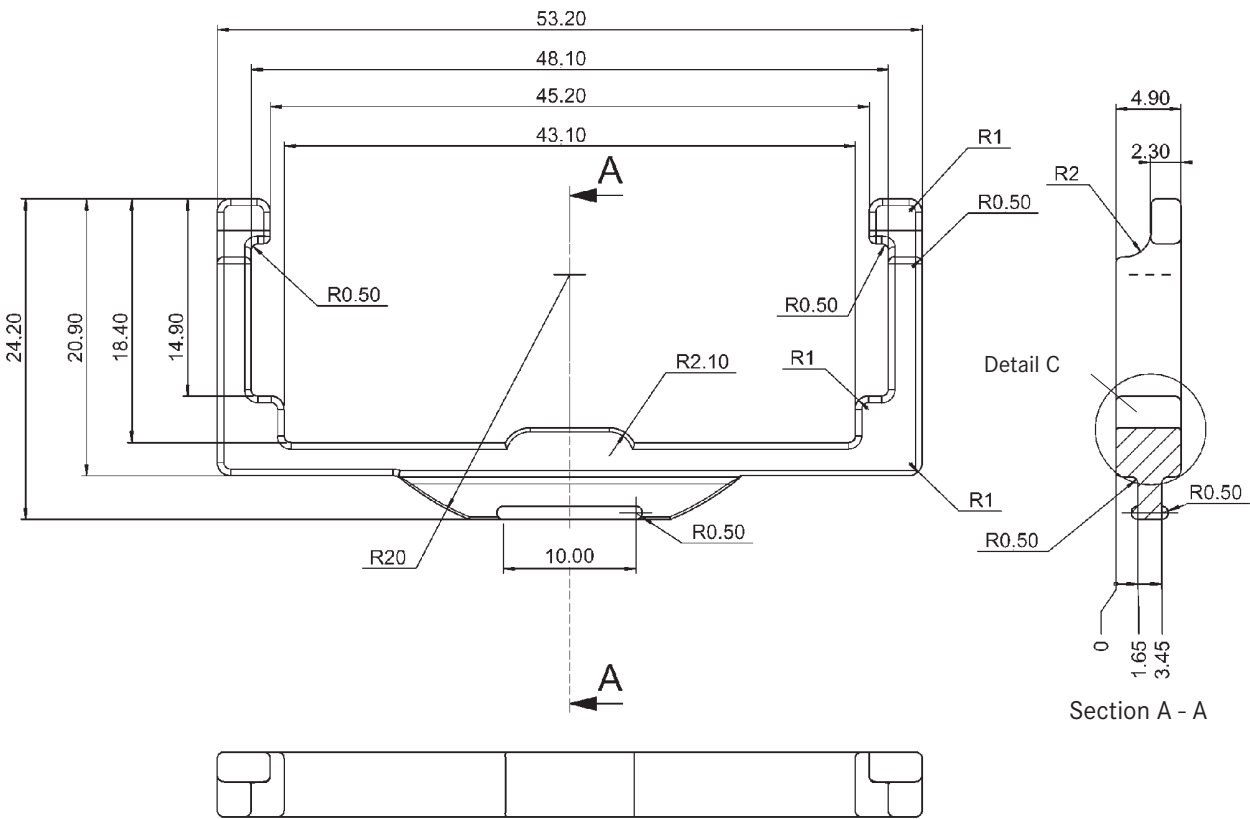

DETAIL C

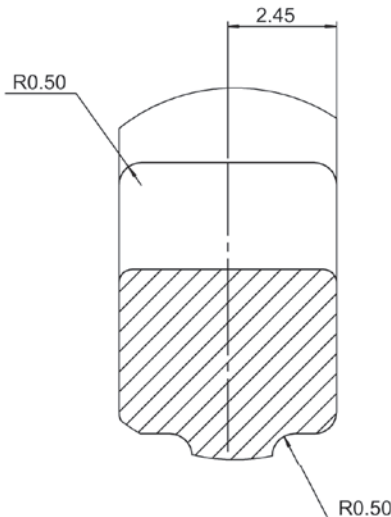

AUSTRIA / EASTERN EUROPE

CODICO GmbH & Co. KG
Zwingenstrasse 6 - 8
2380 Perchtoldsdorf
Austria

Contact: Mr. Christian Sichtar

Tel.: +43 186 305 0
Fax: +43 186 305 5000
e-mail: office@codico.com
Internet: www.codico.com

BENELUX

Logic Technology B.V.
John F. Kennedylaan 18
5981 XC Panningen
The Netherlands

Contact: Mr. René Janssen or
Mr. André de Ceuninck

Tel.: +31 77 307 8438
Fax: +31 77 307 8439
e-mail: info@logic.nl
Internet: www.logic.nl/yamaichi

DENMARK

Cabcon A/S
Stamholmen 193 A
2650 Hvidovre,
Denmark

Contact: Mr. Brian Dehlsen or
Mr. Flemming Schandorph

Tel. +45 38 76 03 15
Fax. +45 38 76 03 20
e-mail: fs@cabcon.dk
internet: www.cabcon.dk

FINLAND

Yleiselektroniikka OY
Po Box 73
Luomantoko 6
02201 Espoo
Finland

Contact: Mr. Kai Nurmenniemi

Tel.: +358 10 2891 200
Fax: +358 10 2891 270
e-mail: kai.nurmenniemi@yeint.fi
Internet: www.yeint.fi

FRANCE

Manudax - France
ZA les Petites Haies
28, rue de Valenton
BP302
94709 Maisons-Alfort Cedex
France

Contact: Mr. Philippe Matoulet or
Mr. Christophe Lazerges

Tel.: +33 1 41 789444
Fax: +33 1 48 994186
e-mail: manudax@manudax.fr
Internet: www.manudax.fr

GERMANY

GLYN GmbH & Co. KG
Am Wörtzgarten 8
65510 Idstein / Taunus
Germany

Contact: Mr. Heiko Keller

Tel.: +49 (0)6126 590342
Fax: +49 (0)6126 590132
e-mail: heiko.keller@glyn.de
Internet: www.glyn.de

ISRAEL

Teder Electro Mechanical Engineering
14 Atir Yeda st.
Kfar-Saba 4464323
Israel

Contact: Mr. Gadi Feit

Tel.: +972 73 2331200
Fax: +972 73 2331233
e-mail: sales@teder.com
Internet: www.teder.com

RUSSIA

YE International
Obukhovskoy Oborony, 70, bld. 3A
St. Petersburg, 192029
Russia

Contact: Mr. Alexander Muraviev

Tel. +7 812 313 34 40 ext.613
Fax. +7 812 313 34 41
e-Mail: alexander.muraviev@yeint.ru
Internet: www.yeint.ru

SWEDEN

Nanomil AB
Vendevägen 90
SE-182 32 Danderyd
Sweden

Contact: Mr. Christian Rassmuson

Tel. +46 8 684 051 42
Fax. +46 739 013 742
e-Mail: christian@nanomil.se
Internet: www.nanomil.se

NORWAY

Link Nordic AS
Gramveien 76
NO - 1801 Askim

Contact: Mr. Yngve Mobrårthen

Tel.: +47 69 88 98 99
Fax: +47 48 1520 71
e-mail: Yngve.Mobrathen@linknordic.com
Internet: www.linknordic.com

SWITZERLAND

Sicovend AG
Alte Poststrasse 1
8310 Kempththal
Switzerland

Contact: Mr. Othmar Stocker

Tel.: +41 52 354 80 24
Fax: +41 52 354 80 00
e-mail: othmar.stocker@sicovend.ch
Internet: www.sicovend.ch

UNITED KINGDOM

Cyntech Components Ltd.
Unit 29, Chancerygate Business Park
Goulds Close, Denbigh West,
Milton Keynes MK1 1EQ
UK

Contact: Mr. Ian Mort

Tel.: +44 (0)1908 37 39 27
Fax: +44 (0)1908 36 53 05
e-mail: sales@cyntech.co.uk
Internet: www.cyntech.co.uk

C

CF024-S9-BL-*-*-TRAY47
 CF050P1S-003-00DS* 51
 CF050P1S-013-00DS*52
 CF050P2 -*03-*0-DS349
 CF050P2-013-*0DS350
 CF050P2S-*13-*0DS*54
 CF050P2S-*03-*0DS*53
 CF050P-003-*DS48
 CF050P2-LT Rev3.055
 CNS-D-*-*-**_*
 (SMT Double Deck)62
 CNS-S-*-*-**_*
 (SMT Single Deck)60
 CNT-D-*-*-**_*
 (TH Double Deck)58
 CNT-S-*-*-**_*
 (TH Single Deck)56

PJS008-2005-*VE30
 PJS008-2120-027
 PJS008-2130-031
 PJS008-2130-126
 PJS008T-0000-033
 PJS008U-3000-032

F

FMA006-3700-040
 FMA006-3800-041
 FMS006-2310-039
 FMS006-2610-036
 FMS006-2620-037
 FMS006-3710-040
 FMS006-3810-041
 FMS006-5100-038
 FMS006Z-200-*34
 FMS006Z-210*-035
 FMS006Z-2000-034
 FMS008-4000*-EDC 43
 FMS008-4000-SW**EDC 43
 FMS008-6001-0 42
 FPS009-2305-0 12
 FPS009-2409-0 10
 FPS009-2901-0 6
 FPS009-2903-0-VE 8
 FPS009-2920-0 16
 FPS009-2960-0 14
 FPS009-2970-0 18
 FPS009-3001-BL20
 FPS009-3002-BL20
 FPS009-3003-BL 20
 FPS009-3202-BL22
 FPS009-4200-0 (03)23
 FPS017T-1000-FL-TRAY25
 FPS017T-2000-FL-TRAY24
 FRS016T-2000-0V346
 FUA006-3210-045
 FUA006-3220-045
 FUS006-3210-045
 FUS006-8500-044

P

PCMCIA-1088-*62
 PCMCIA-1260-*60
 PJS008-2003-129
 PJS008-2004-0-VE28

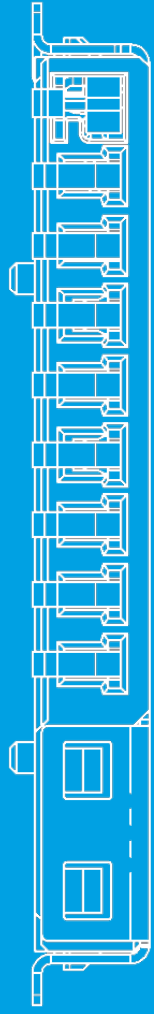

14.50 (記事1.) Note1.

0.60 ±0.15

0.60 ±0.15

1.10 × 7 = 7.70 ±0.15

2.525 ±0.15

6.325 ±0.15

1.10 ±0.15 (ピッチPitch)

8-0.40 ±0.10

0.45 ±0.10

A

(1.85)

③

⑧

#8
#7
#6
#5
#4
#3
#2
#1

0.90

(2-0.40)

B

14.80

14.60

9.40 ±0.20

A

B

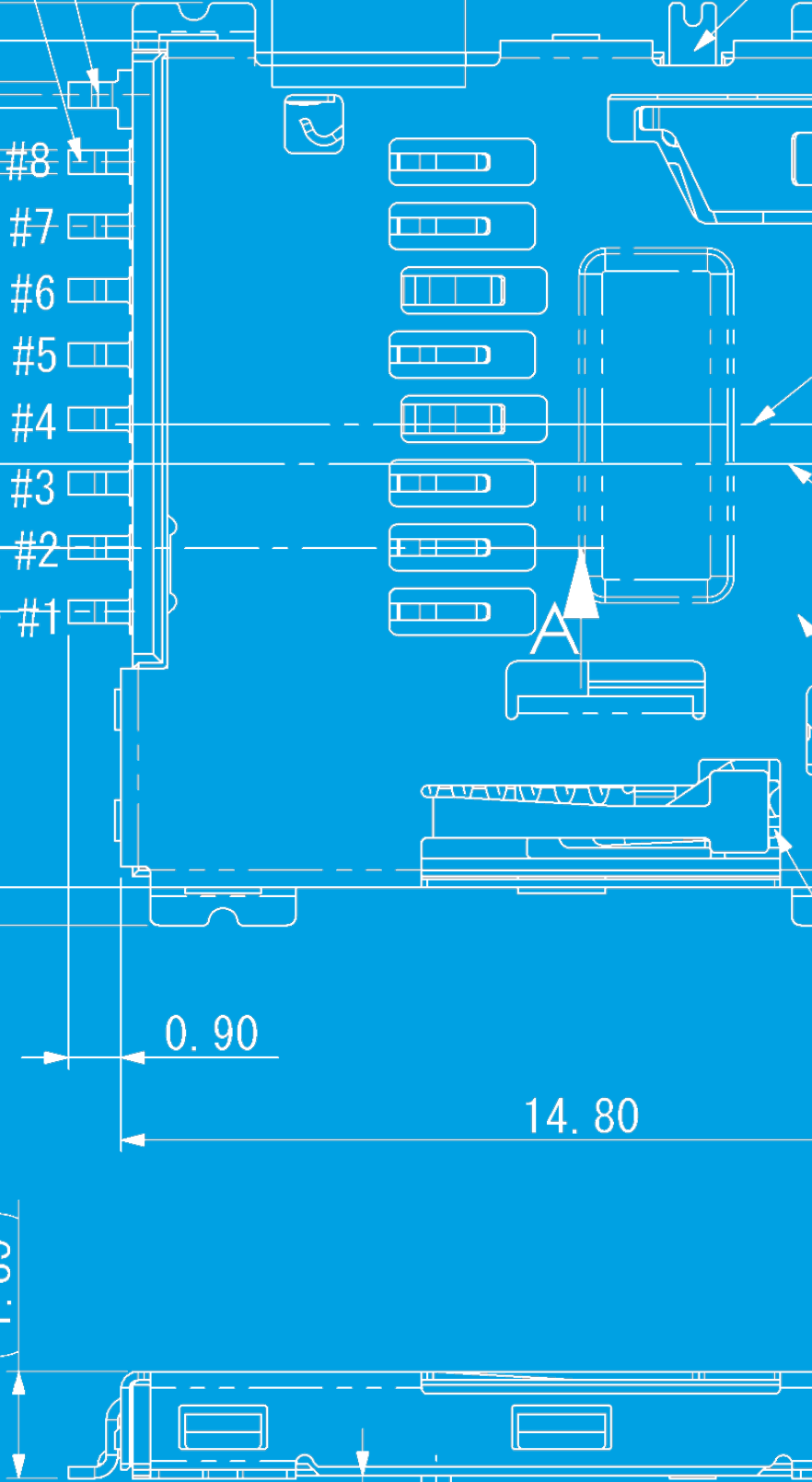

CARD CONNECTORS

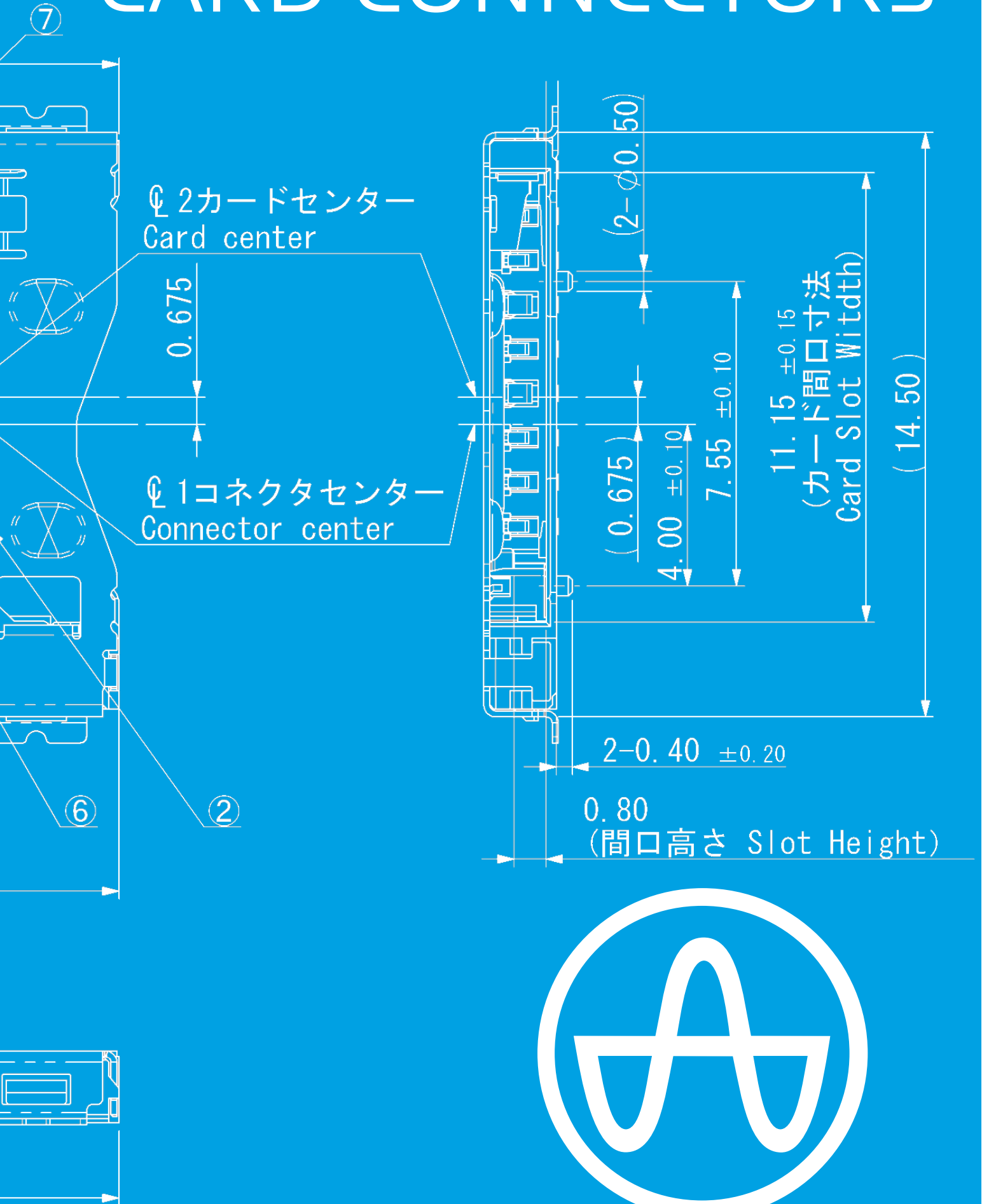



CARD CONNECTORS

Version November 2018

TECHNICAL DATA ARE SUBJECT TO ALTERATION WITHOUT PRIOR NOTICE

YAMAICHI ELECTRONICS

Deutschland GmbH
Concor Park
Bahnhofstraße 20
85609 Aschheim-Dornach
Germany

Phone +49 (0)89 45109-0
Fax +49 (0)89 45109-110
E-Mail sales@yamaichi.de
Web www.yamaichi.de

YAMAICHI ELECTRONICS

Italia s.r.l.
Centro Direzionale Colleoni
Via Colleoni, 1
Palazzo Taurus Ing. 1
20864 Agrate Brianza (MB)
Italy

Phone +39 039 6881-185
Fax +39 039 6892-150
E-Mail sales@yamaichi.it
Web www.yamaichi.it

YAMAICHI ELECTRONICS

GB Ltd.
6 The Clockhouse
Stratton Park
Micheldever
Hampshire SO21 3DP
Great Britain

Phone +44 (0)7808 493377
Fax +44 (0)1962 774902
E-Mail sales@yamaichi.co.uk
Web www.yamaichi.co.uk