



# CARD CONNECTORS

## COMPATIBLE FLASH MEMORY CARDS

SERIES FPS, PJS, FMS, FUS, CF.....5

## SD AND MMC

SERIES FPS.....6 - 25

## MICROSD

SERIES PJS.....26 - 33

## SIM

SERIES FMS.....34 - 43

## MICROSIM AND NANOSIM

SERIES FUS.....44 - 45

## COMPACT FLASH

SERIES CF.....47 - 55

## BACK PAGES

EUROPEAN DISTRIBUTORS  
PART NUMBER INDEX

### YAMAICHI ELECTRONICS FACTS & FIGURES

Foundation:	Headquarters, Tokyo: 1956 European Headquarter, Aschheim near Munich: 1986
Turnover:	Worldwide 230 m € p.a., Europe 75 m € p.a.
Employees:	Over 2,100, in Europe 285
Certification:	DIN EN ISO 9001:2015 (HQ and production EU) ISO 14001:2015 (production in Frankfurt/Oder) ISO/TS 16949 (selected production sites)
Locations:	Worldwide 7 production sites, 6 design centers, 13 sales locations

as of May 2018

### PRODUCT RANGE

Yamaichi Electronics designs, manufactures and markets high performance interconnection devices, also for use in the most demanding applications of electronic systems: with high temperature environments, protected interconnections for harsh environments and high-speed interconnections for data networking applications. The portfolio covers high precision fine pitch IC sockets, connectors, cable assemblies and flexible printed circuits.

### YAMAICHI EUROPE

Yamaichi Electronics Deutschland GmbH, located in Aschheim near Munich, is your European partner for connectivity solutions covering Industrial, Automotive, Measurement & Testing, Data Networking, Medical and Embedded & Semiconductor applications.

#### Two Divisions:

**Connector Solutions:** Portfolio: Connectors for Industrial use, for example circular connectors Y-Circ® M (M12) and Y-Circ® P (Push-Pull), Y-Con® Series (RJ45 and USB). Automotive connectors FAKRA/HSD, Quadlock (Y-QUAD) and others, card connectors, high speed connector systems and latest input /output connectors. Internal connectors for high end applications (Y-Lock® series). Data networking connectors, cables and cable assemblies as well as production sockets.

**Test Solutions:** Portfolio: IC semiconductor test & burn-in sockets, modular test contactors, test adapter systems for computer-on-modules, receptacles, spring probe pins, PCB design.

**In all product areas we offer customer specific solutions.**

### ENGINEERING

Two design centers in Munich (Germany) and Sousse (Tunisia) react quickly to market challenges and work with the most modern technologies for the realisation of customer needs from product ideas to qualified mass production. Two fully equipped inhouse test laboratories allow internal product qualification and guarantee convincing product quality.

### PRODUCTION FOR THE EUROPEAN MARKET

In our production facility in Frankfurt (Oder) we have been manufacturing connectors and complex cable assemblies for e.g. industrial or medical applications since 2006. In the area of test solutions we produce high end test contactors, module test adapters and receptacles. We offer special know-how in overmolding, welding, resistance welding and machining technologies. To ensure highest quality and short delivery times we have a high grade of vertical range of manufacturing and established a reliable European supplier network.

### YAMAICHI ELECTRONICS ZAHLEN & FAKTEN

Firmengründung:	Konzernsitz, Tokyo: 1956 Europäische Zentrale, Aschheim bei München: 1986
Umsatz:	weltweit 230 Mio € p.a., Europa 75 Mio € p.a.
Mitarbeiter:	über 2.100 weltweit, 285 in Europa
Zertifizierung:	DIN EN ISO 9001:2015 (HQ und Produktion EU) ISO 14001:2015 (Produktion in Frankfurt/Oder) ISO/TS 16949 (ausgewählte Produktionsstandorte)
Standorte:	weltweit 7 Produktionsstandorte, 6 Design-Zentren, 13 Vertriebszentren

### LEISTUNGSSPEKTRUM

Yamaichi Electronics entwickelt, produziert und vermarktet hochleistungsfähige elektromechanische Komponenten, auch für anspruchsvollste Anwendungen in elektronischen Systemen: für den Hochtemperaturbereich, geschützt für den Einsatz unter rauen Umgebungsbedingungen und High Speed Verbindungstechnik für Daten networking Anwendungen. Das Portfolio umfasst hochpräzise Fine pitch IC Sockel, Steckverbinder, Kabelassemblierungen und flexible Leiterplatten.

### YAMAICHI EUROPA

Yamaichi Electronics Deutschland GmbH, mit Sitz in Aschheim bei München, ist Ihr europäischer Ansprechpartner für Verbindungstechnik. Lösungen für Applikationen in: Automatisierung, Automotive, Meß- und Prüftechnik, Data Networking, Medizintechnik und Halbleiterindustrie.

#### Zwei Bereiche:

**Connector Solutions:** Portfolio: Industriesteckverbinder, z.B. Rundsteckverbinder Y-Circ® M (M12) und Y-Circ® P (Push-Pull), Y-Con® (RJ45 and USB). Automotive Steckverbinder FAKRA/ HSD, Quadlock (Y-QUAD) und andere spezielle Automotive Lösungen, Kartensteckverbinder, High Speed Steckverbindersysteme und neueste Input /Output Steckverbinder. Interne Steckverbinder für High End Applikationen (Y-Lock® Serie). Data Networking Steckverbinder, Kabel und Kabelassemblierungen, Produktionssockel.

**Test Solutions:** Portfolio: IC Halbleiter Test & Burn-In Sockel, modulare Test Contactoren, Test Adapter Systeme für Computer-on-Modules, Receptacles, Federkontaktstifte, PCB Design.

**In allen Produktbereichen bieten wir kundenspezifische Lösungen an.**

### ENGINEERING

Mit zwei Design-Zentren in München und Sousse (Tunesien) ist die schnelle Reaktion auf Marktanforderungen und Kundenwünsche sichergestellt. Unser Entwicklungsteam arbeitet mit den modernsten Technologien zur Realisierung von Kundenanforderungen. Umfangreich ausgestattete hauseigene Testlabore ermöglichen die interne Qualifizierung von Produkten und gewährleisten überzeugende Produktqualität.

### PRODUKTION FÜR DEN EUROPÄISCHEN MARKT

An unserem Fertigungstandort in Frankfurt (Oder) werden seit 2006 Steckverbinder und komplexe Kabelassemblierungen für z.B. Industrie- oder Medizinanwendungen hergestellt. Im Bereich Test Solutions werden High End Test Contactors, Modultestadapter und Receptacles gefertigt. Wir bieten Spezial-Know How in den Fertigungstechnologien Spritzguss, Schweißen, Widerstandsschweißen und Zerspanungstechnik. Die hohe Fertigungstiefe sowie in Europa ansässige zuverlässige Zulieferfirmen garantieren hochwertige Produkte und kurze Lieferzeiten.

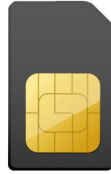

**FEATURES**

Yamaichi Series

**SECURE DIGITAL & MMC**

FPS009

**SIM**

FMS

**MICROSIM**

FUS

**NANOSIM**

FUS

Series Page Number

26 - 33

26 - 33

44 -45

44 - 45

Read/Write [MB/s]

2.5 / 2.5

-

-

-

Write Protect

no

-

-

-

Voltage

2.7 ~ 3.6

-

-

-

Op. Temp. Range

-25 ~ +85°C

-25~ +85°C

-25 ~ +85°C

-25~ +85°C

# of Pads

9 (SD) 7 (MMC)

8

8

8

Weight (g)

1.5

-

-

-

Volume (mm<sup>3</sup>)

1,075

(281)

(281)

(281)

Dimensions

24 x 32 x 2.1

15 x 25 x 0.76

12 x 15 x 0.76

1?? x 25 x 0.76

Association

[www.sdcard.org/www.mmca.org](http://www.sdcard.org/www.mmca.org)

[www.etsi.org](http://www.etsi.org)

[www.etsi.org](http://www.etsi.org)

[www.etsi.org](http://www.etsi.org)

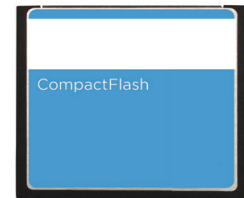

**FEATURES**

Yamaichi Series

**MICROSD**

PJS008

**CFAST (CF)**

CF050

**COMPACT FLASH (CF)**

CF050

Series Page Number

26 - 33

47 - 55

47 - 55

Read/Write [MB/s]

12.5 / 12.5

up to 600

20 / 20

Write Protect

yes

no

no

Voltage

2.7 ~ 3.6

3.3 / 5.0

3.3 / 5.0

Op. Temp. Range

-25 ~ +85°C

-40 ~ +85°C

0 ~ +70°C

# of Pads

8

24

50

Weight (g)

0.4

~10

Typ.I: 11.4 / Typ.II: 13.5

Volume (mm<sup>3</sup>)

165

5141

Typ.I: 5,141 / Typ.II: 7,790

Dimensions

11 x 15 x 1.0

42.8 x 36.4 x 3.6

42.8 x 36.4 x 3.3/ (Typ.II 5.0)

Association

[www.sdcard.org](http://www.sdcard.org)

[www.compactflash.org](http://www.compactflash.org)

[www.compactflash.org](http://www.compactflash.org)  
as of Nov 2014

**SPECIFICATIONS**

Insulation Resistance:	1,000MΩ min. at 500V DC
Withstanding Voltage:	500V ACrms for 1 minute
Contact Resistance:	100mΩ at 1mA / 40mV max.
Voltage Rating:	5V DC
Current Rating:	0.5A
Operating Temp. Range:	-25°C to +85°C
Coplanarity:	≤ 0.1mm
Mating Cycles:	10,000 (office environment)

**MATERIALS AND FINISH**

Insulator:	LCP
Shielding Plate:	Stainless Steel,
Contacts:	Copper Alloy
	Contact Area: Ni-Au
	Solder Tail: Ni-Sn



**PART NUMBER**

**FPS 009 - 290\* - 0**

Series No.	↑
Number of Contacts	↑
Design No.* 1= sides Tin plating 4= sides Ni plating with Au on solder terminal 5= side Ni plating with Au on solder terminal	↑
0 = Tape & Reel Packaging	↑

**FEATURES**

- Connector for both card types (MMC and SD card)
- Smooth extraction function by Push-in/ Push-out of card
- Soft lock mechanism for SD card
- Super low profile (Ht. 2.80 x W. 28.10 x L. 27.10)
- Tape & Reel packaging (500 pcs / reel)
- Card detector
- Write protection switch
- Mechanism to avoid flying out of the card
- Closed cover
- RoHS2011/65/EU

**OUTLINE DIMENSIONS**

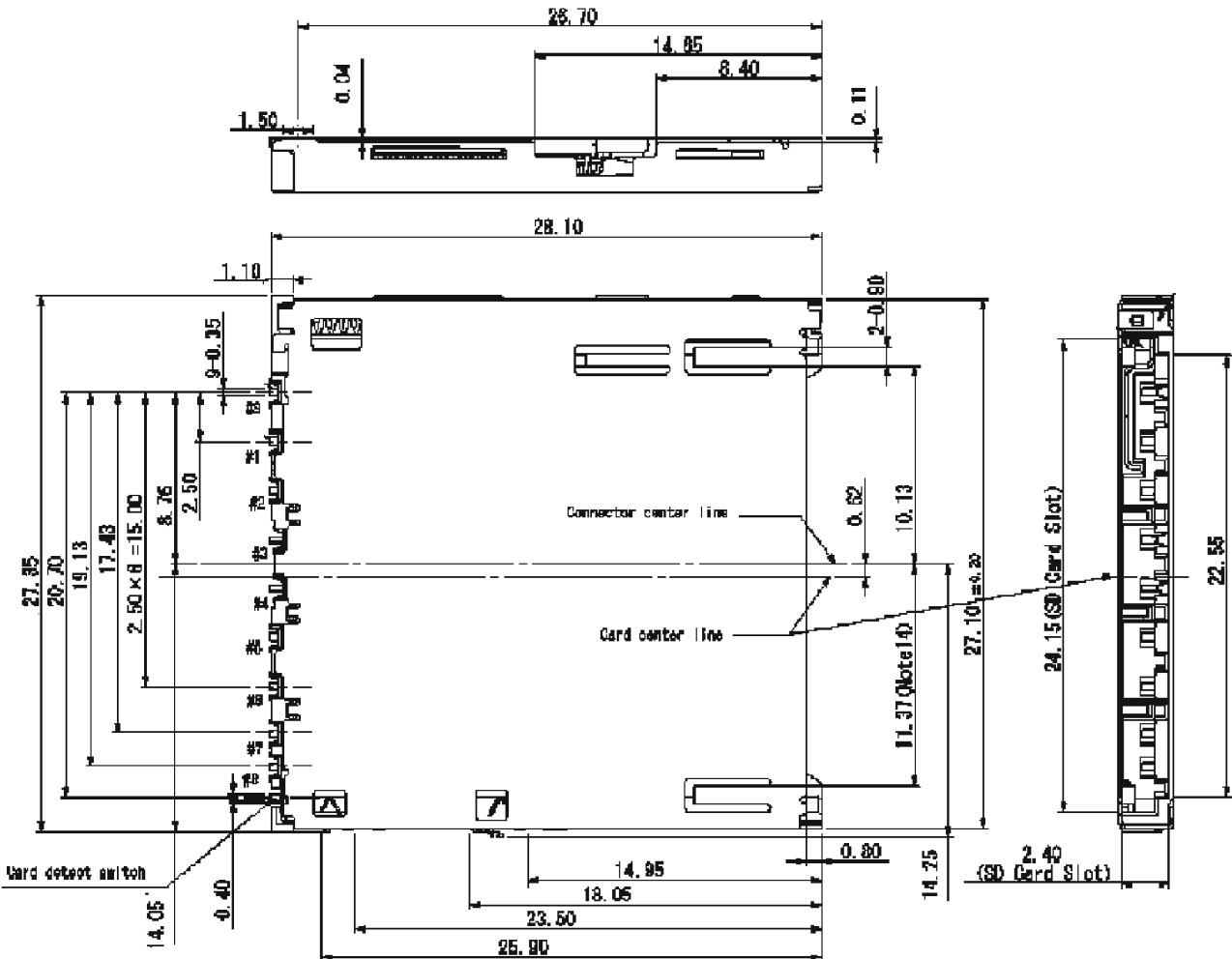



**SPECIFICATIONS**

Insulation Resistance:	1,000MΩ min. at 500V DC
Withstanding Voltage:	500V ACrms for 1 minute
Contact Resistance:	100mΩ at 1mA / 20mV max.
Voltage Rating:	5V DC
Current Rating:	0.5A
Operating Temp. Range:	-25°C to +85°C
Mating Cycles:	5,000 (harsh environment) 10,000 (office environment)

**MATERIALS AND FINISH**

Insulator:	LCP
Shielding plate:	Stainless
Contact:	Copper Alloy
	Contact area: Ni-Au
	Solder tail: Ni-Sn

**AUTOMOTIVE  
COMPLIANT**

**PART NUMBER**

FPS 009 - 2903 - 0 - VE

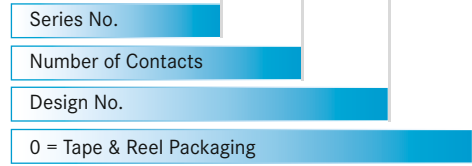

**FEATURES**

- SD reader for harsh environment with automotive applications
- Connector for both card types (MMC and SD card)
- Smooth extraction function by Push-in/ Push-out of card
- Tape & Reel packaging (500 pcs / reel)
- EMI prevention with four grounding terminals
- Card detector
- Write protection switch
- RoHS2011/65/EU

**OUTLINE DIMENSIONS**

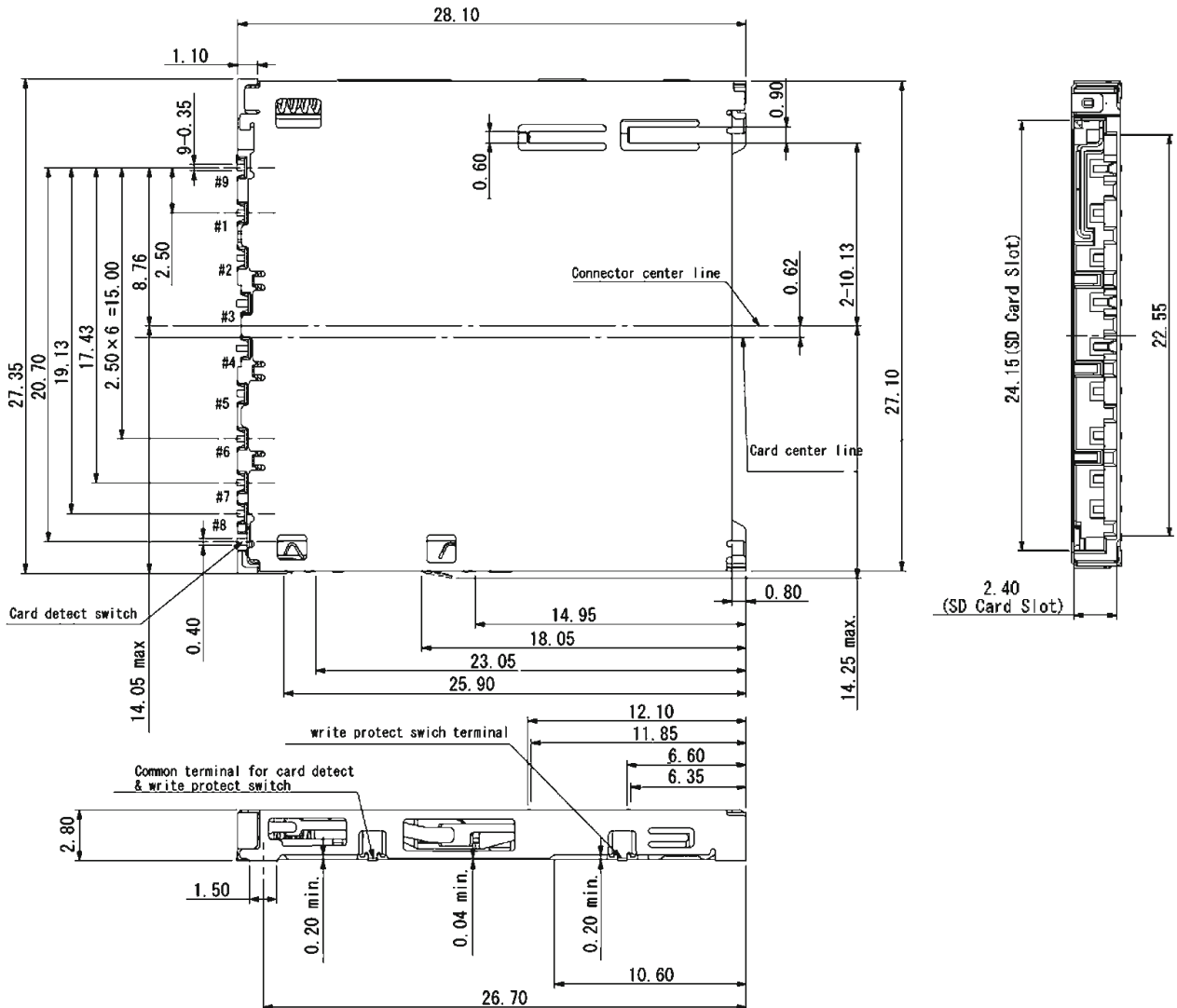

RECOMMENDED PCB LAYOUT FOR FPS009-2903-OVE

Top View

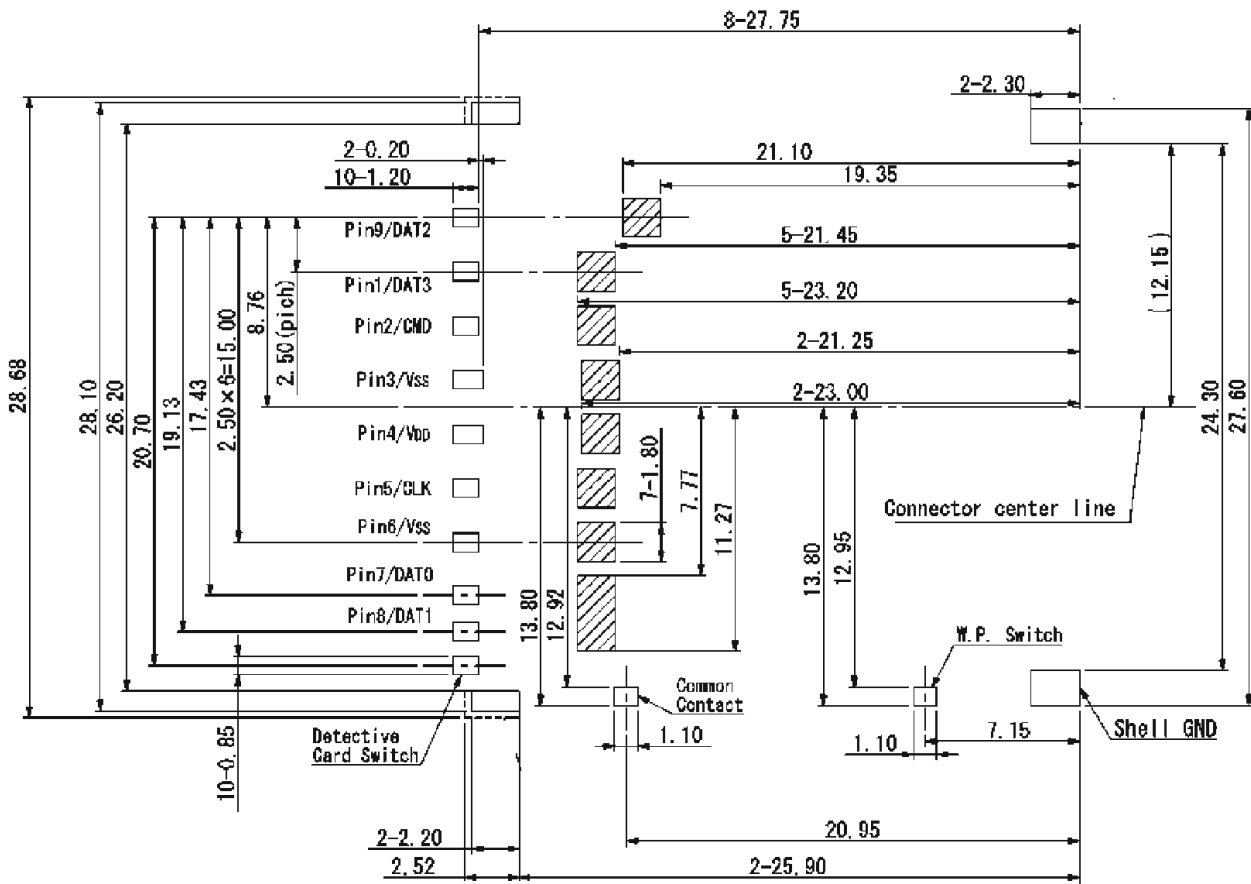

CIRCUIT DIAGRAM FOR SWITCH

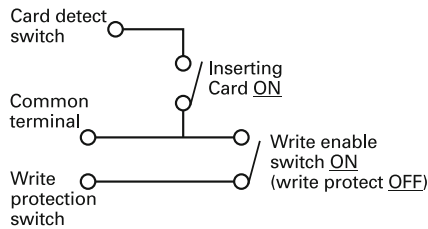

CARD INSERTION DETAILS

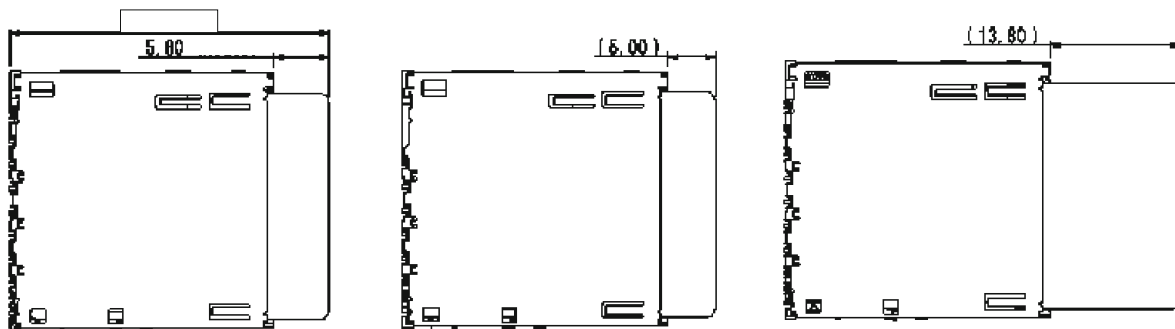

Card locked position

Card pushed position

Card eject position

**SPECIFICATIONS**

Insulation Resistance:	1,000MΩ min. at 500V DC
Withstanding Voltage:	500V ACrms for 1 minute
Contact Resistance:	100mΩ at 1mA / 20mV max.
Voltage Rating:	250Vrms AC
Current Rating:	0.5A
Operating Temp. Range:	-25°C to +85°C
Coplanarity:	≤ 0.1mm
Mating Cycles:	10,000 (office environment)

**PART NUMBER**

FPS 009 - 2409 - 0

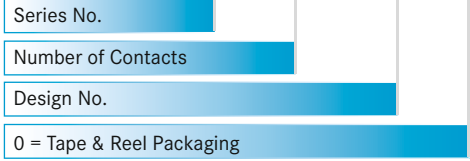

**MATERIALS AND FINISH**

Insulator:	LCP
Shielding Plate:	SUS
Contacts:	Copper Alloy
	Contact Area: Ni-Au
	Solder Tail: Ni-Sn

**AUTOMOTIVE COMPLIANT**

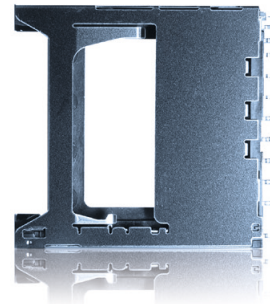

**FEATURES**

- Connector for both card types (MMC and SD card)
- Card detector
- Smooth extraction function by Push-in/ Push-out of card
- Soft lock mechanism for SD card
- Tape & Reel packaging (600 pcs / reel)
- Two-point contact, protection against electrical interruption
- Write protection switch
- Mechanism to avoid flying out of the card
- RoHS2011/65/EU

**OUTLINE DIMENSIONS**

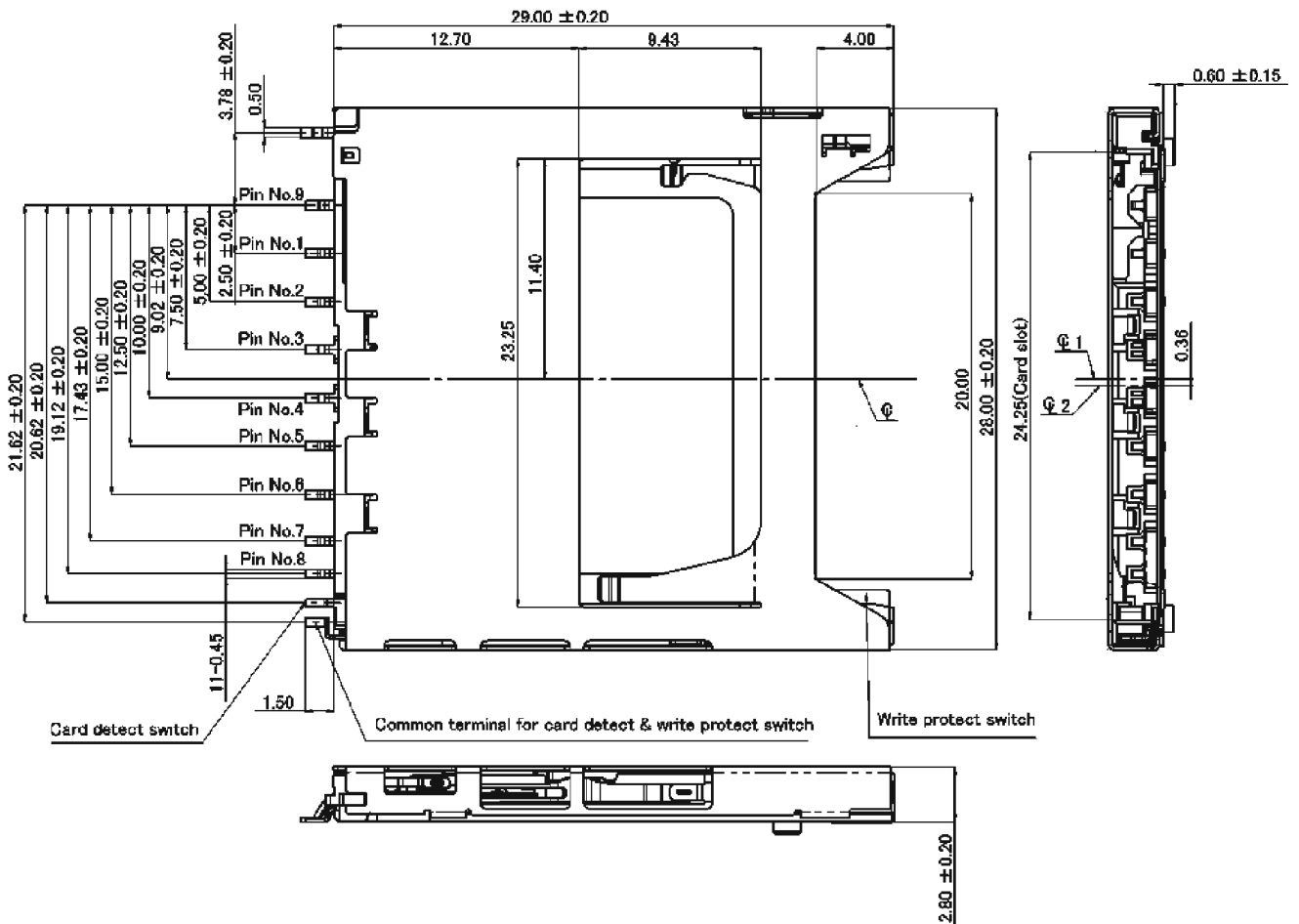

**RECOMMENDED PCB LAYOUT FOR FPS009-2409-0**

Top View

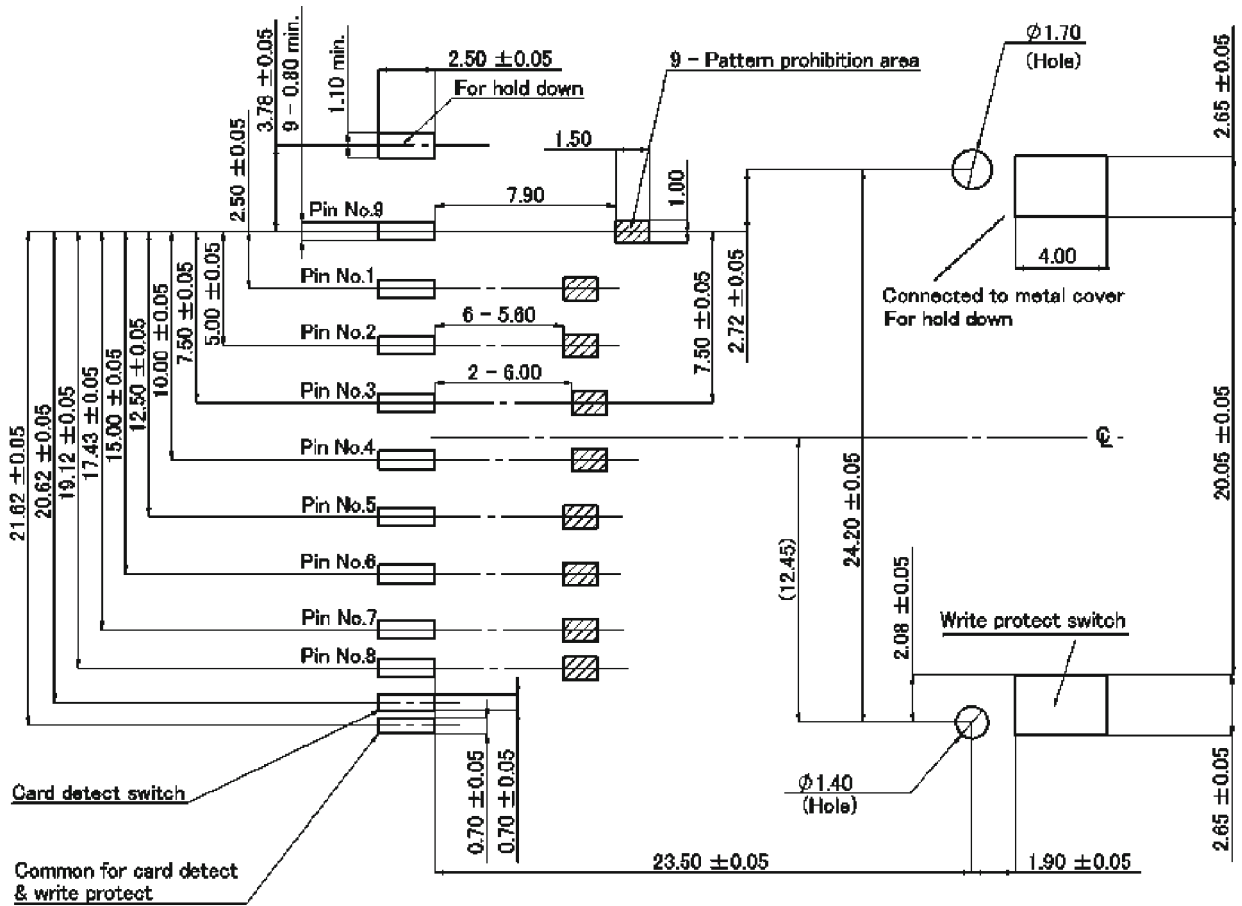

**CIRCUIT DIAGRAM FOR SWITCH**

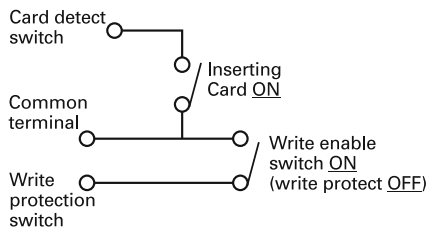

**CARD INSERTION DETAILS**

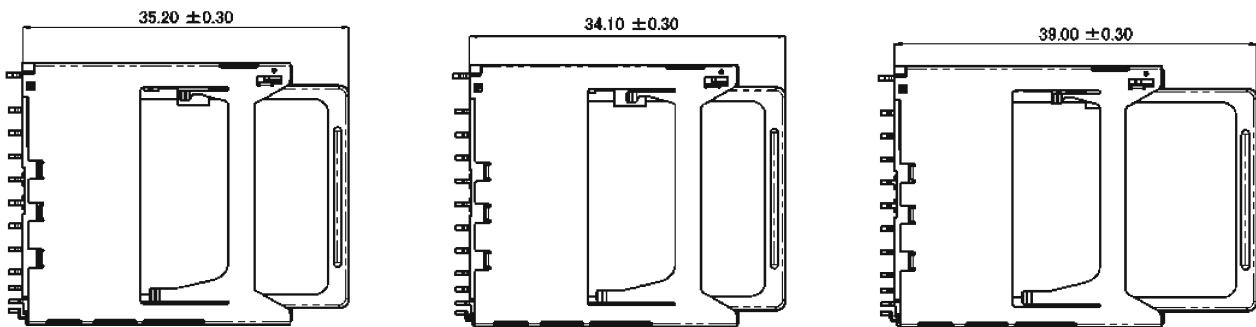

Card locked position

Card pushed position

Card eject position

**SPECIFICATIONS**

Insulation Resistance:	1,000MΩ min. at 500V DC
Withstanding Voltage:	500V ACrms for 1 minute
Contact Resistance:	100mΩ at 1mA / 20mV max.
Voltage Rating:	250Vrms AC
Current Rating:	0.5A
Operating Temp. Range:	-25°C to +85°C
Coplanarity:	≤ 0.1mm
Mating Cycles:	10,000 (office environment)

**MATERIALS AND FINISH**

Insulator:	LCP
Shielding Plate:	SUS, t = 0.2
Contacts:	Copper Alloy: t = 0.15
	Contact Area: Ni-Au
	Solder Tail: Ni-SnCu

**FEATURES**

- Connector for both card types (MMC and SD card)
- Smooth extraction function by Push-in/ Push-out of card
- Soft lock mechanism for SD card
- Tape & Reel packaging (500 pcs per reel)
- Mechanism to avoid flying out of the card
- Small size (Ht. 3.1 x W. 28.0 x L. 29.8)
- 2-point contact, protection against electrical interruption
- Card detector and Write protection switch
- RoHS2011/65/EU

**OUTLINE DIMENSIONS**

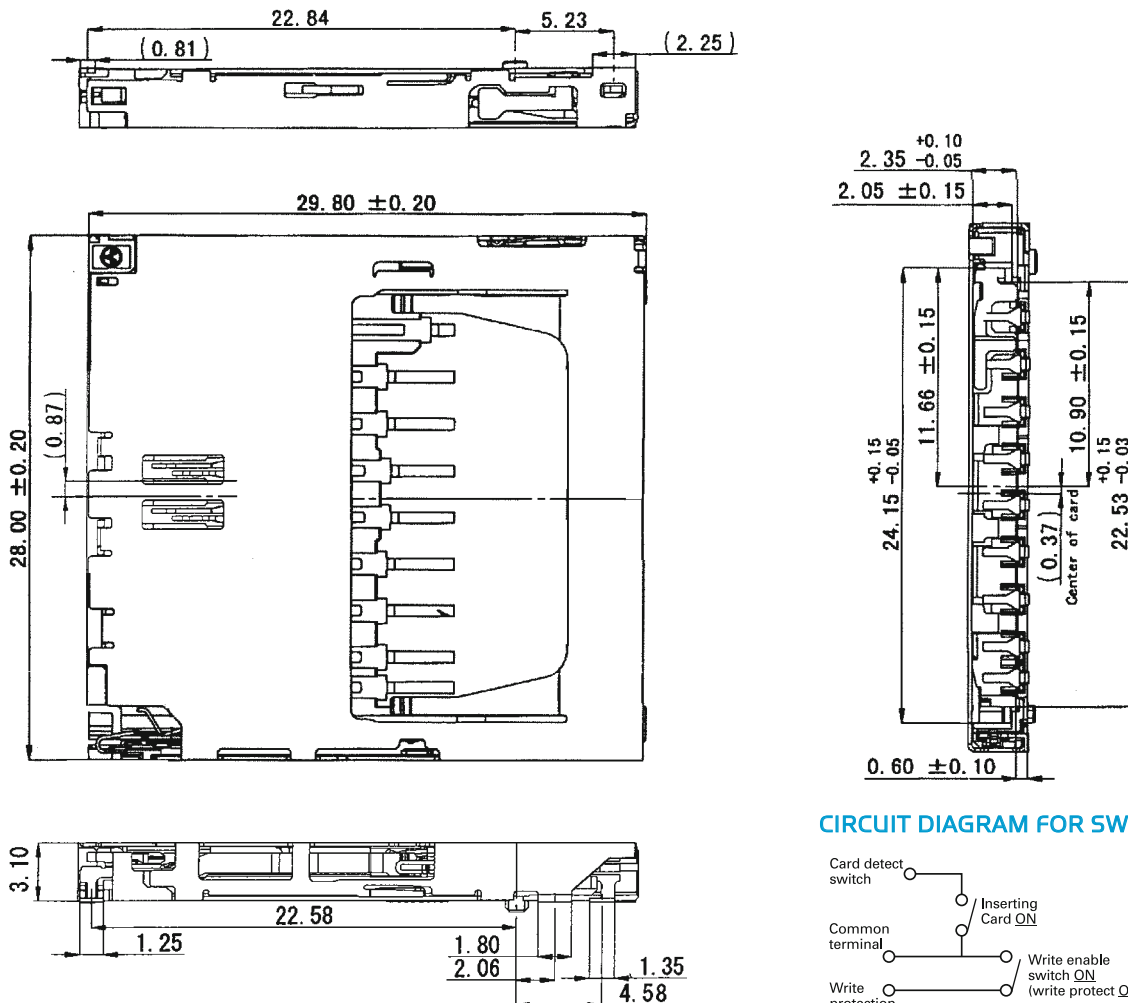

**PART NUMBER**

**FPS 009 - 2305 - 0**

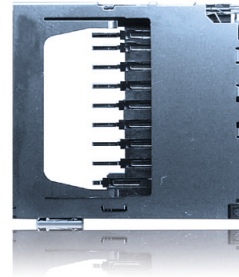
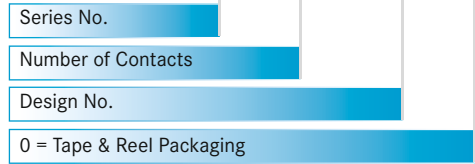

**CIRCUIT DIAGRAM FOR SWITCH**

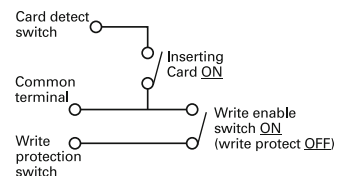

RECOMMENDED PCB LAYOUT FOR FP5009-2305-0

Top View

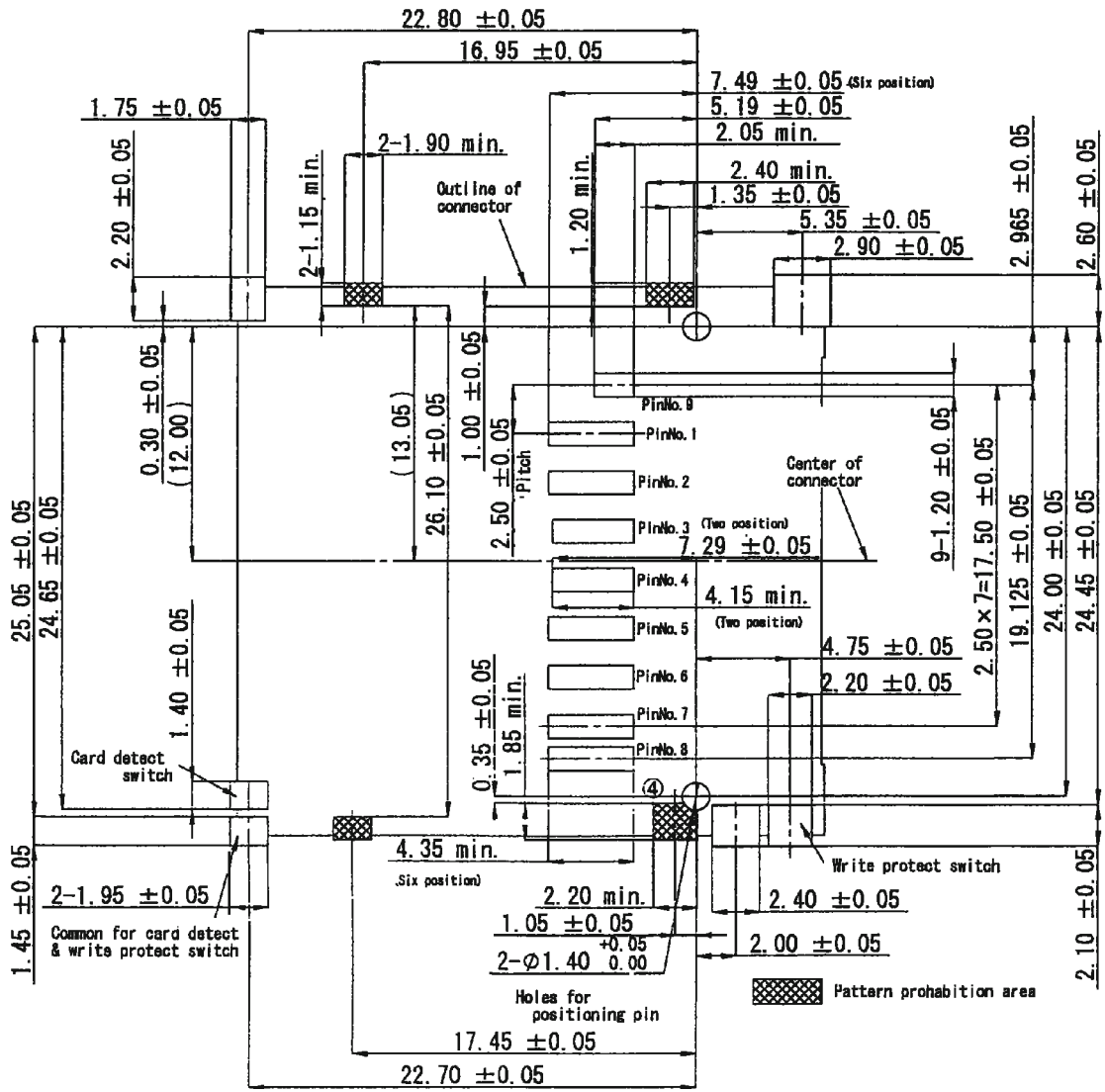

CARD INSERTION DETAILS

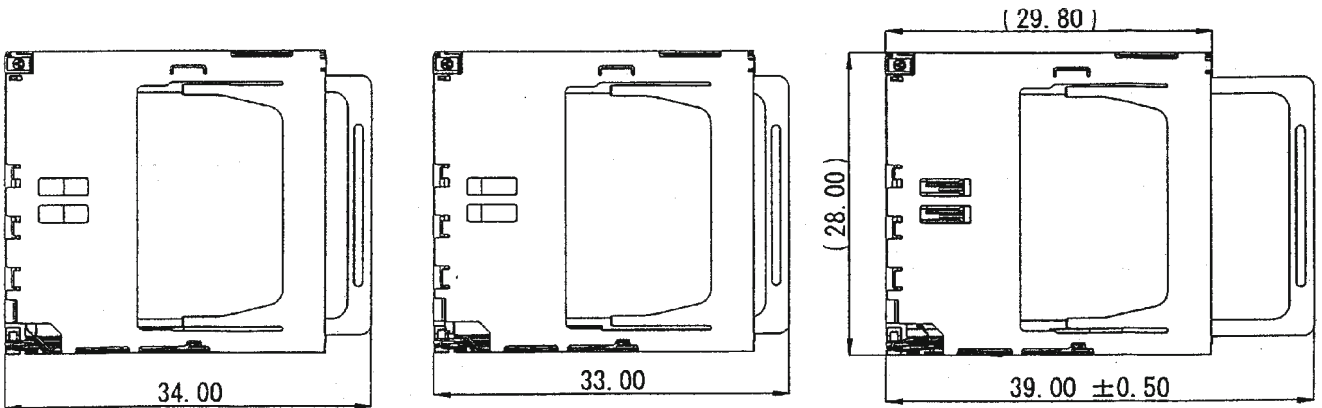

Card locked position

Card pushed position

Card eject position



**RECOMMENDED PCB LAYOUT FPS009-2960-0**

Top View

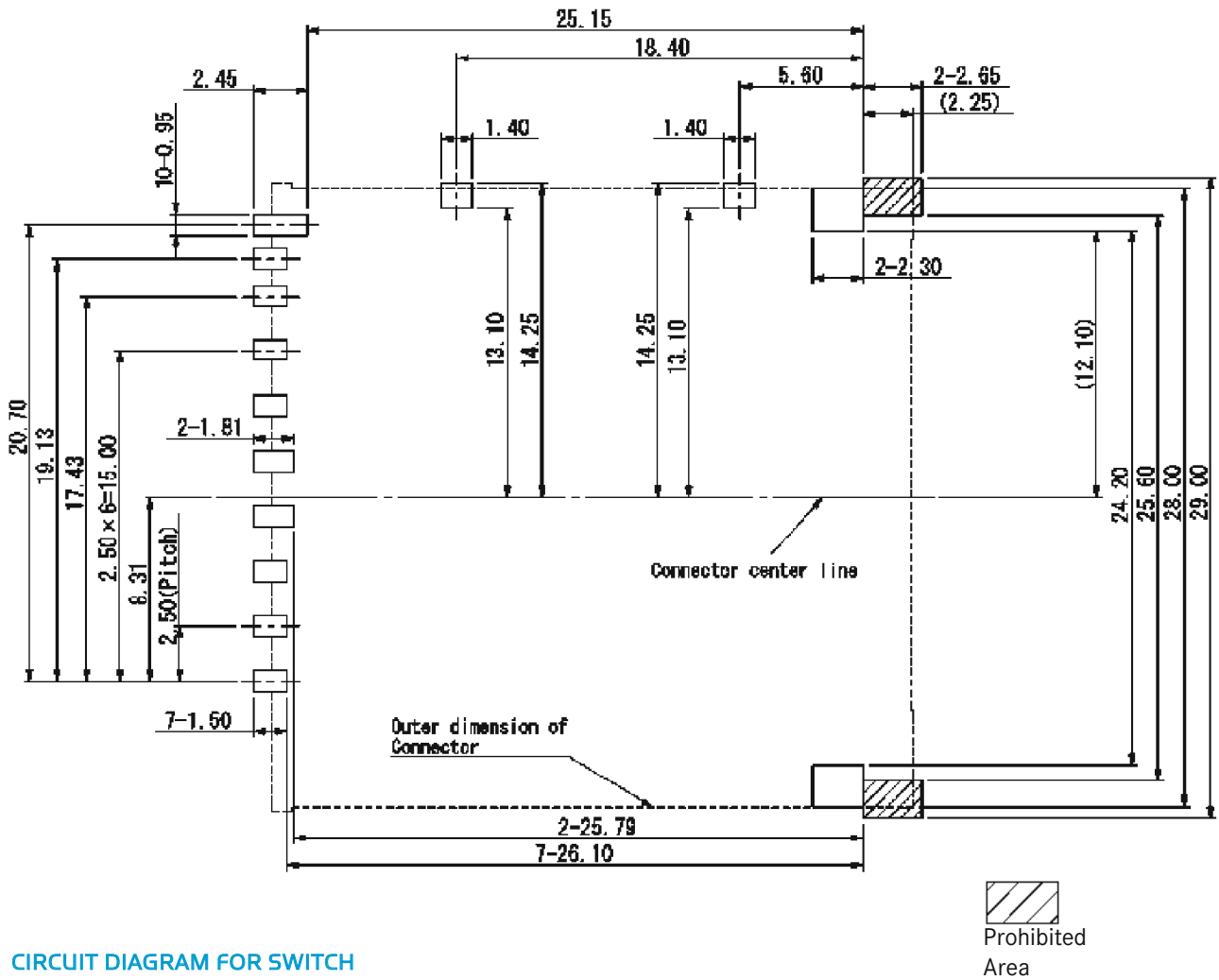

**CIRCUIT DIAGRAM FOR SWITCH**

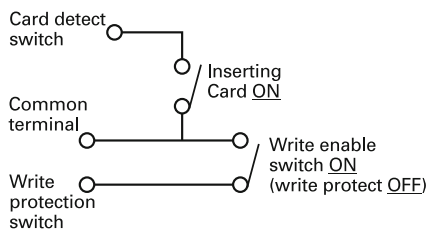

**CARD INSERTION DETAILS**

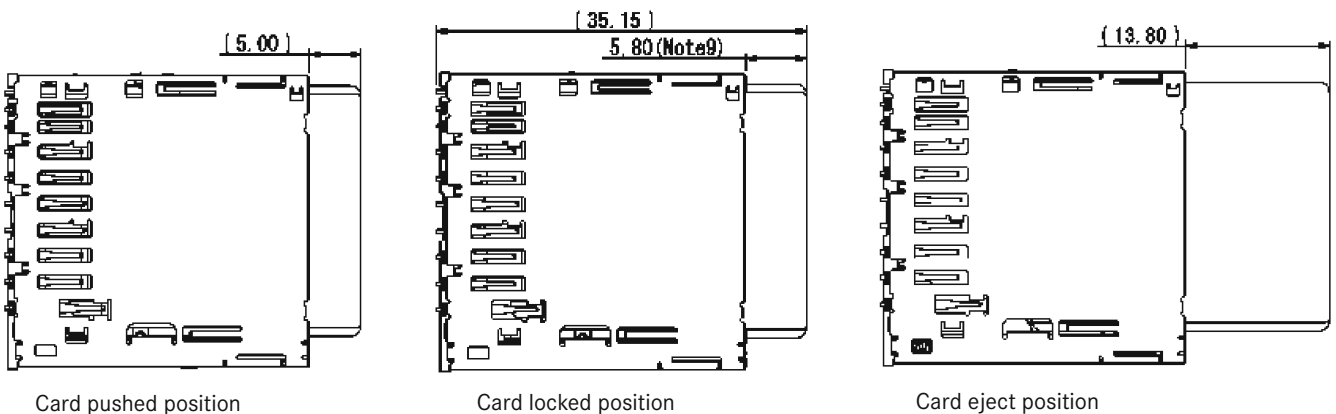

**SPECIFICATIONS**

Insulation Resistance:	1,000MΩ min. at 500V DC
Withstanding Voltage:	500V ACrms for 1 minute
Contact Resistance:	100mΩ at 1mA / 40mV max.
Voltage Rating:	5V DC
Current Rating:	0.5A
Operating Temp. Range:	-25°C to +85°C
Mating Cycles:	10,000 (office environment)

**PART NUMBER**

FPS 009 - 2920 - 0

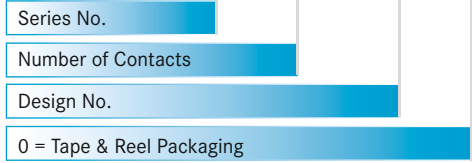

**MATERIALS AND FINISH**

Insulator:	LCP
Shielding plate:	Stainless
Contact:	Copper Alloy: t=0.15
	Contact Area: Ni-Au
	Solder Tail: Ni-Sn

**AUTOMOTIVE COMPLIANT**



**FEATURES**

- Card stay detection switch at the slot area
- EMI prevention with four grounding terminals
- Smooth extraction function by Push-in/ Push-out of card
- Write protection switch
- SDIO capable
- Tape & Reel packaging (500 pcs / reel)
- RoHS2011/65/EU

**OUTLINE DIMENSIONS**

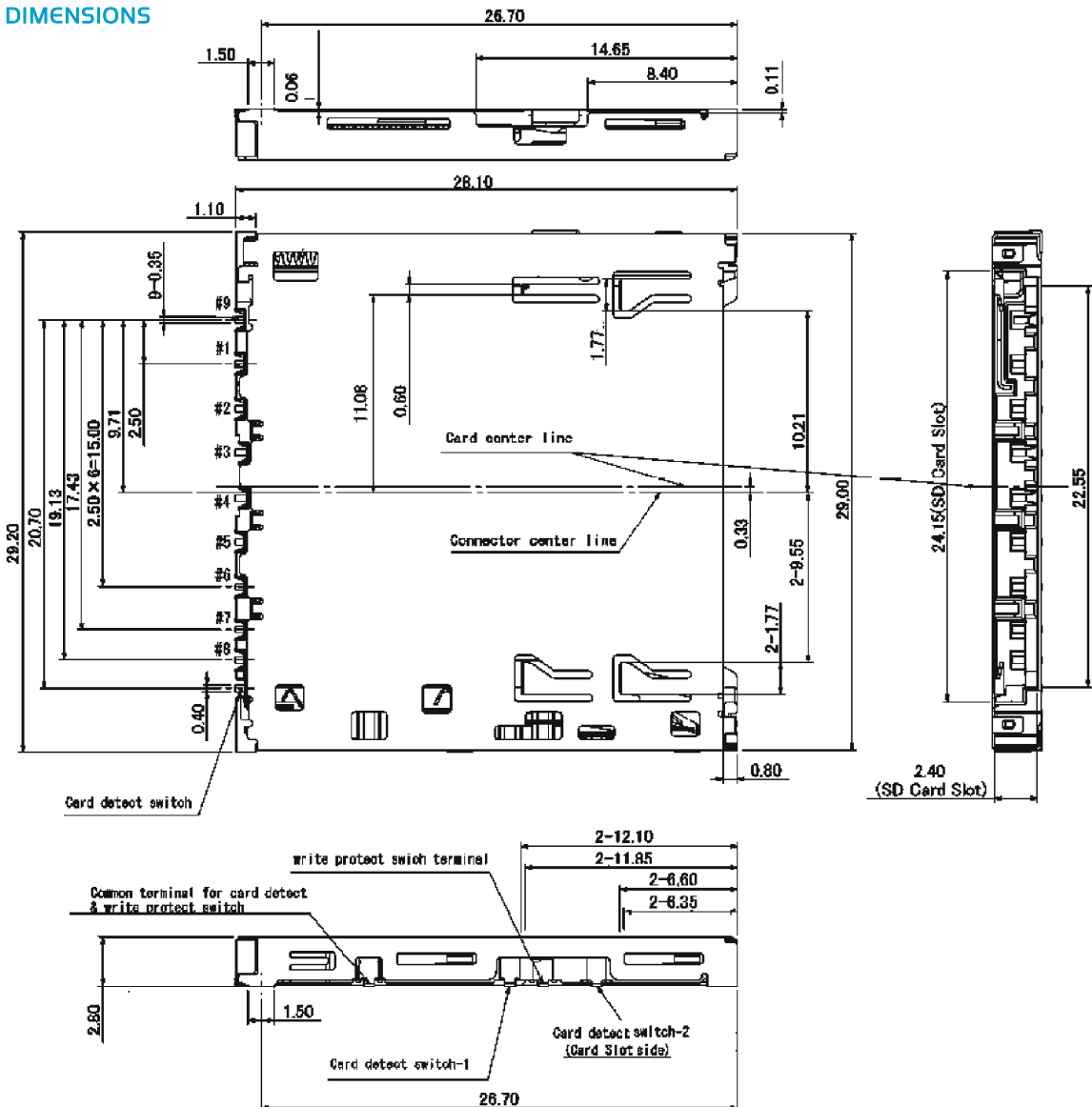

RECOMMENDED PCB LAYOUT FOR FP5009-2920-0

Top View

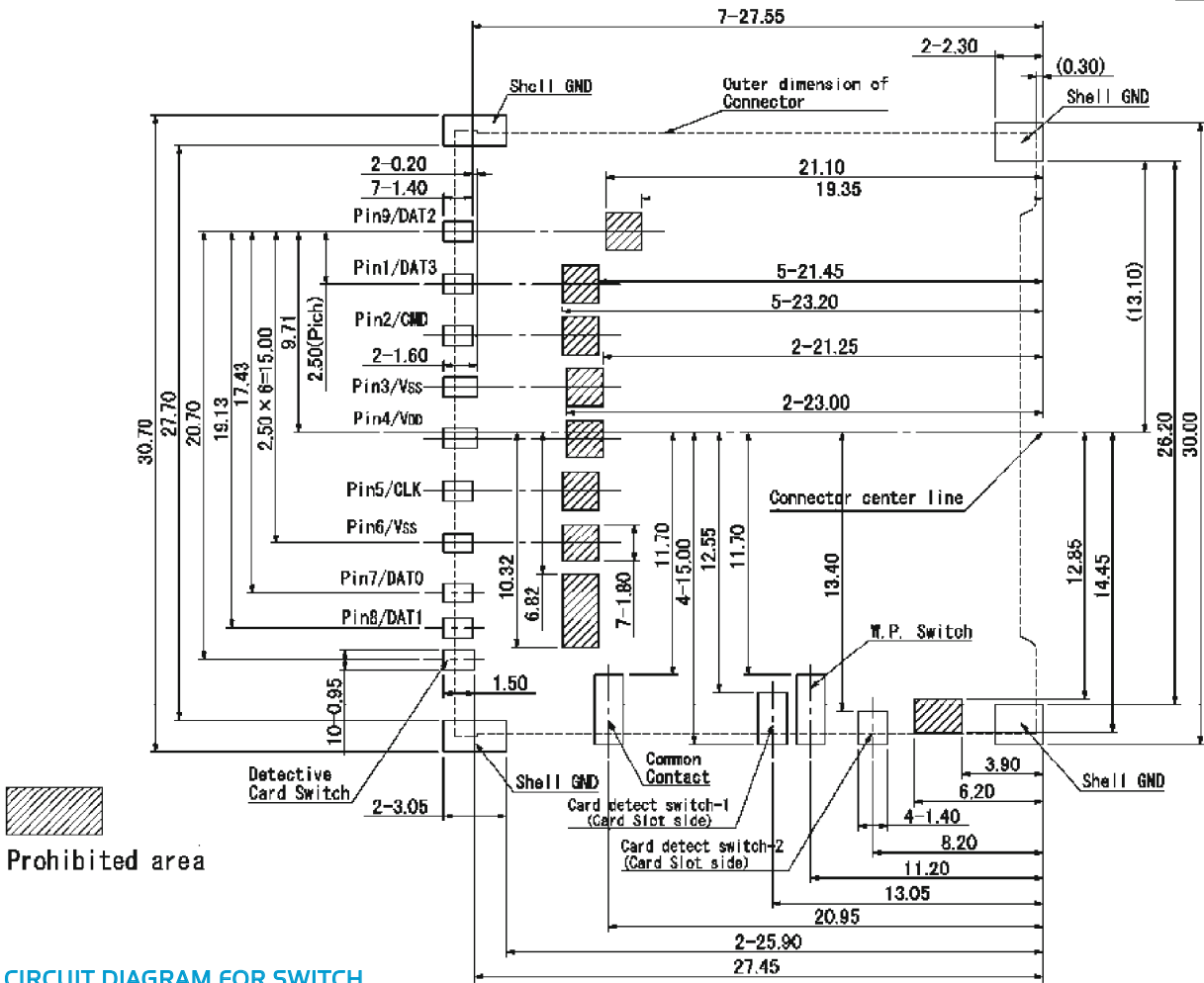

CIRCUIT DIAGRAM FOR SWITCH

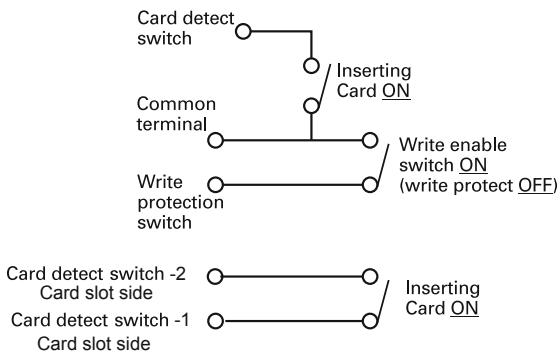

CARD INSERTION DETAILS

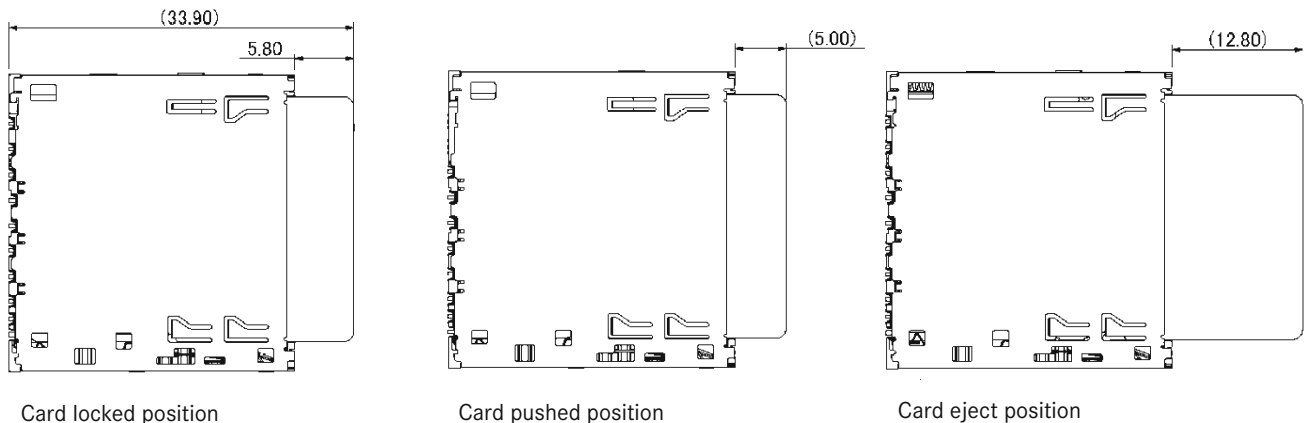

**SPECIFICATIONS**

Insulation Resistance:	1,000MΩ min. at 500V DC
Withstanding Voltage:	500V ACrms for 1 minute
Contact Resistance:	100mΩ at 1mA / 40mV max.
Voltage Rating:	5V DC
Current Rating:	0.5A
Operating Temp. Range:	-25°C to +85°C
Mating Cycles:	10,000 (office environment)

**MATERIALS AND FINISH**

Insulator:	LCP
Shielding plate:	Stainless
Contact:	Copper Alloy: t=0.15
	Contact Area: Ni-Au
	Solder Tail: Ni-Sn

**AUTOMOTIVE  
COMPLIANT**

**PART NUMBER**

**FPS 009 - 2970 - 0**

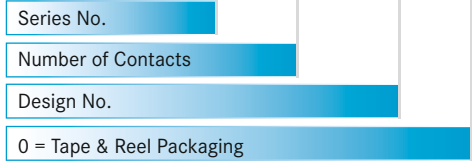

**FEATURES**

- Card stay detection switch at the slot area
- EMI prevention with four grounding terminals
- Smooth extraction function by Push-in/ Push-out of card
- Write protection switch
- SDIO capable
- Tape & Reel packaging (400 pcs / reel)
- RoHS2011/65/EU



**OUTLINE DIMENSIONS**

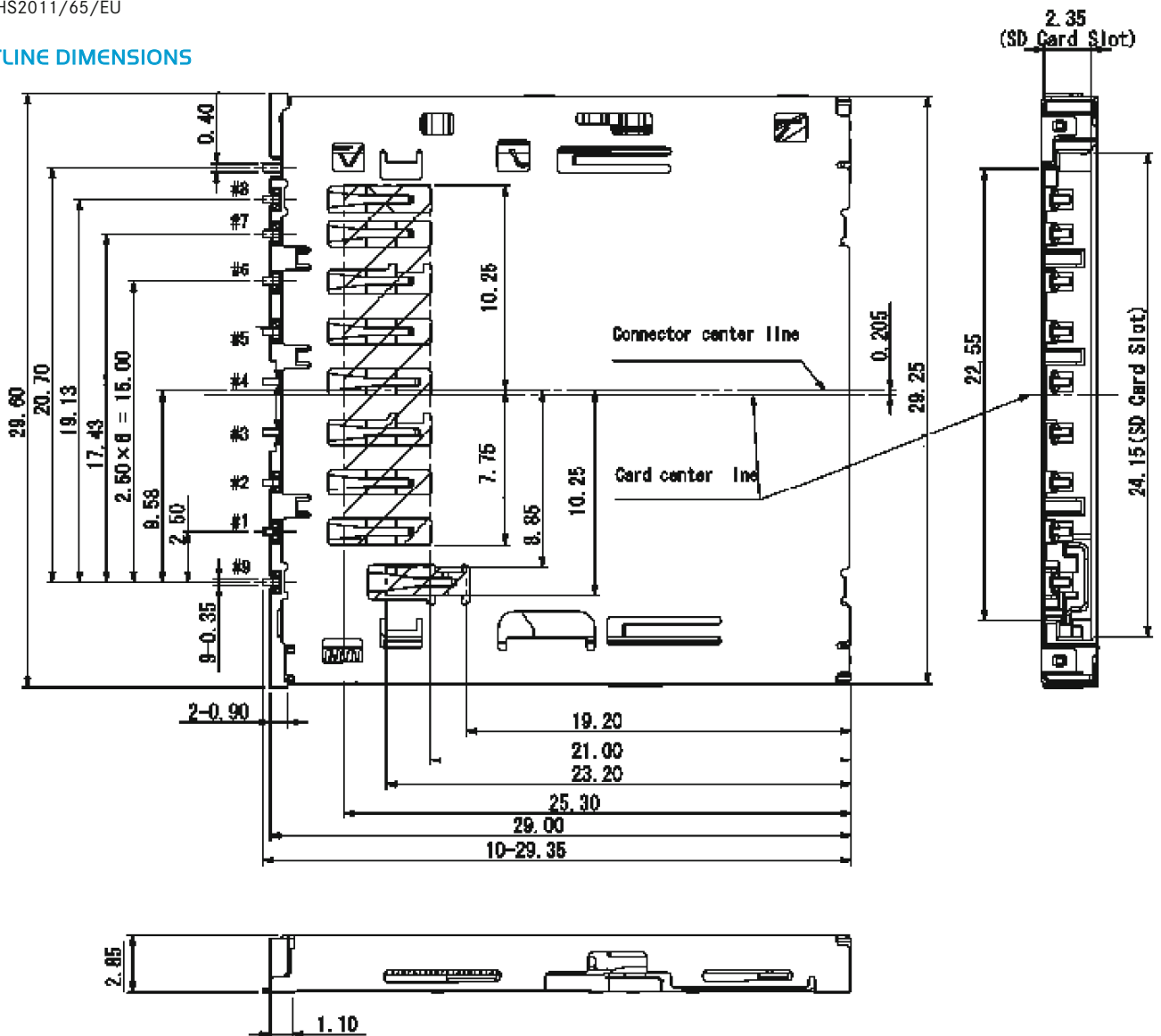

RECOMMENDED PCB LAYOUT FOR FPS009-2970-0

Top View

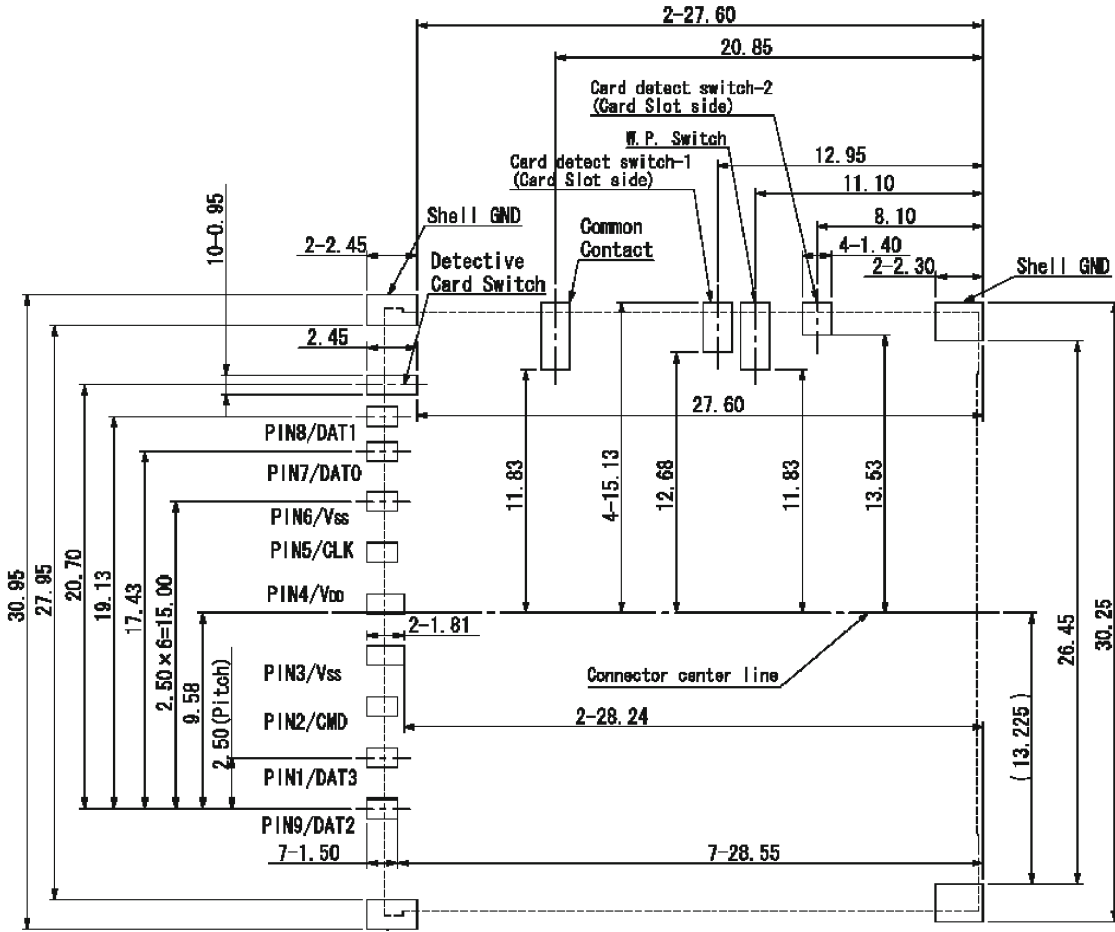

CIRCUIT DIAGRAM FOR SWITCH

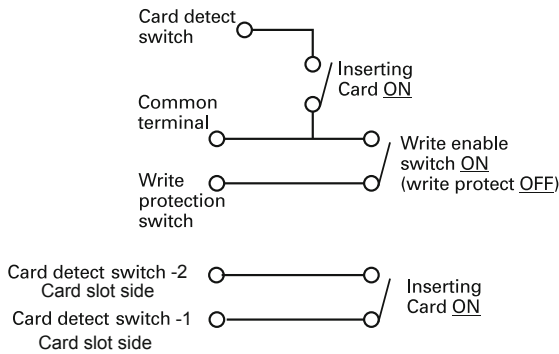

CARD INSERTION DETAILS

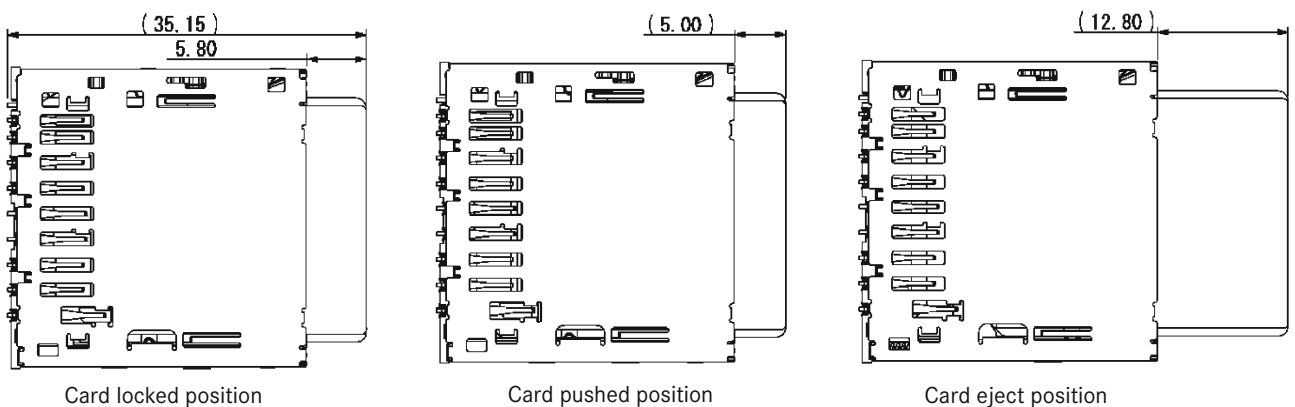

**SPECIFICATIONS**

Insulation Resistance:	1,000MΩ min. at 500V DC
Withstanding Voltage:	500V ACrms for 1 minute
Contact Resistance:	100mΩ at 1mA / 20mV max.
Voltage Rating:	250Vrms AC
Current Rating:	0.5A
Operating Temp. Range:	-25°C to +85°C
Coplanarity:	≤ 0.15mm
Mating Cycles:	10,000 (office environment)

**MATERIALS AND FINISH**

Insulator:	LCP
Shielding plate:	Stainless, t = 0.23
Contacts:	Copper Alloy
	Contact Area = Ni-Au
	Solder Tails = Ni-SnCu
Write Protection:	Copper Alloy, Ni-Au
Card Detector:	Copper Alloy, Ni-Au
Ejector:	LCP

**FEATURES**

- Easy operation by manual insertion / extraction
- 3 step sequential contacting design
- Card detector and write protection (optional)
- Tape and Reel packaging (500 pcs / reel)
- RoHS2011/65/EU

**OUTLINE DIMENSIONS**

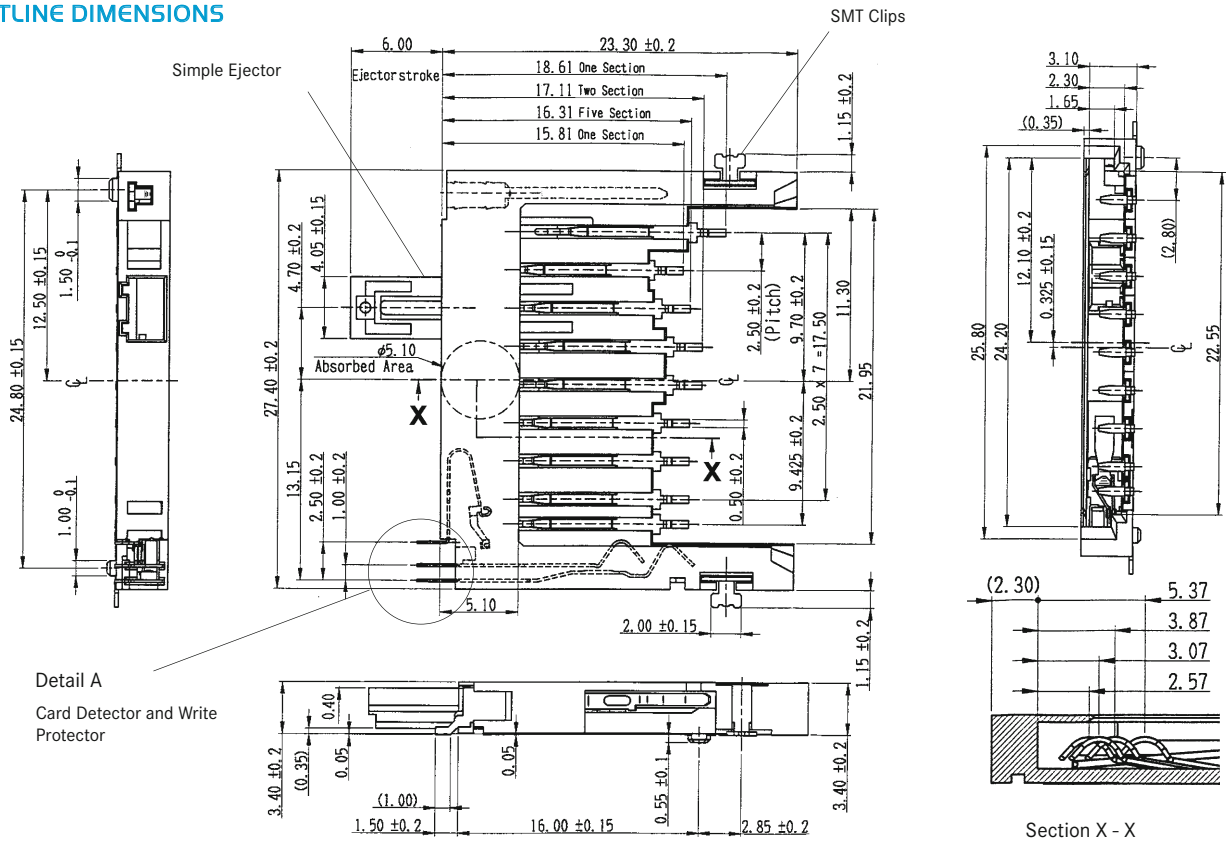

**PART NUMBER**

FPS 009 - 300 \* - BL

Series No.	↑
Number of Contacts	↑
Design No.	↑
1 = with Ejector 2 = without Ejector 3 = without Ejector and Switch	

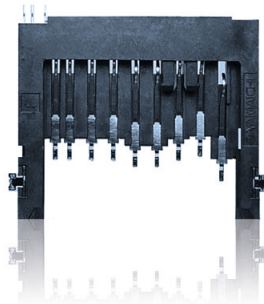

**FUNCTION TABLE**

Part Number	Ejector	Card Detector	SMT Clips	Write Protection Switch
FPS009-3001-BL	Yes	Yes	Yes	Yes
FPS009-3002-BL	-	Yes	Yes	Yes
FPS009-3003-BL	-	-	Yes	-

**RECOMMENDED PCB LAYOUTS FPS009-3001-BL AND FPS009-3002-BL**

Top View

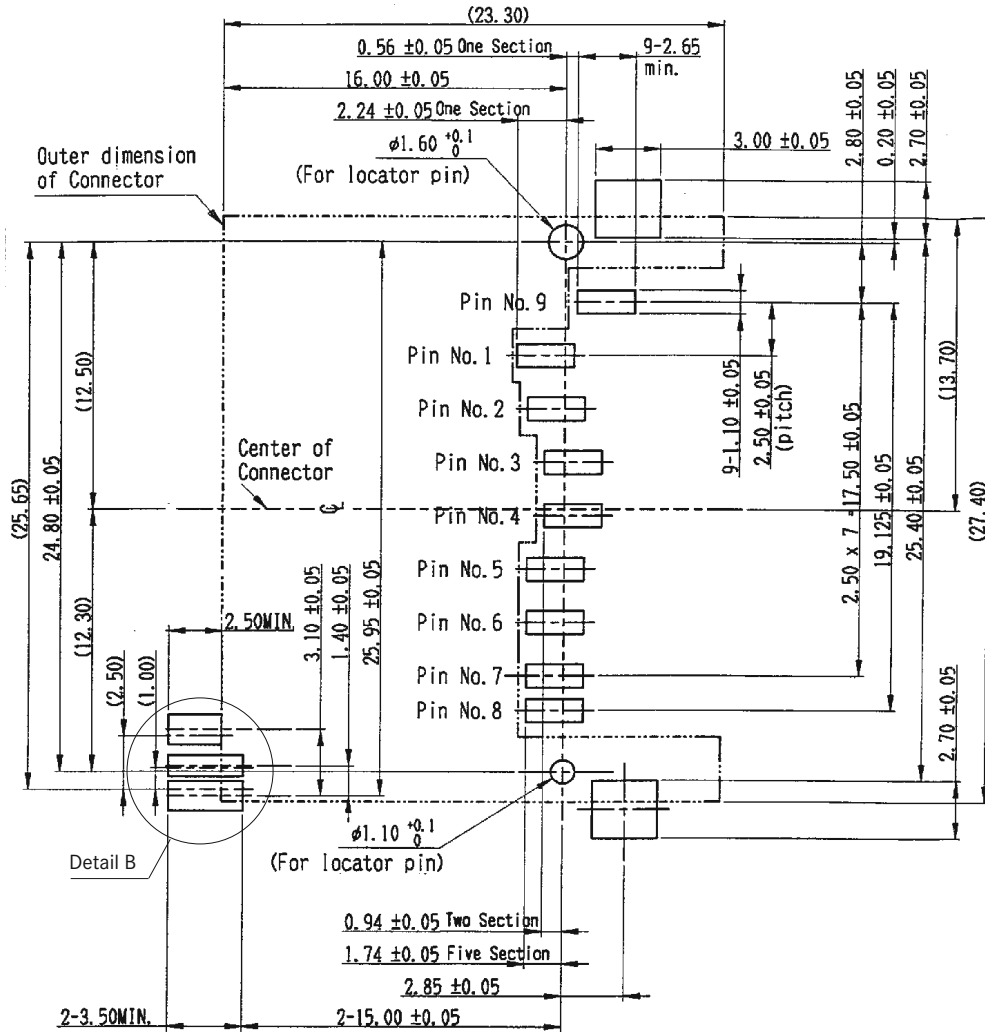

**DETAIL A (CARD DETECTOR / WRITE PROTECTOR)**

**DETAIL B (PCB LAYOUTS)**

FPS009-3001-BL and FPS009-3002-BL

FPS009-3001-BL and FPS009-3002-BL

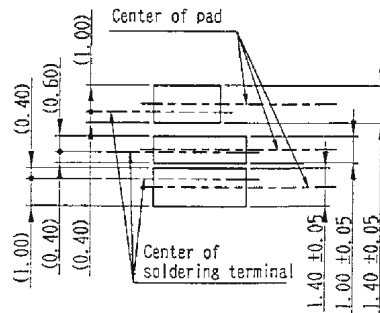
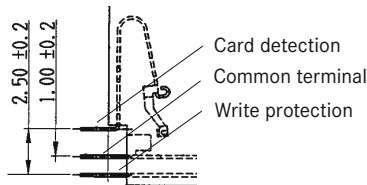

**CIRCUIT DIAGRAM FOR SWITCH**

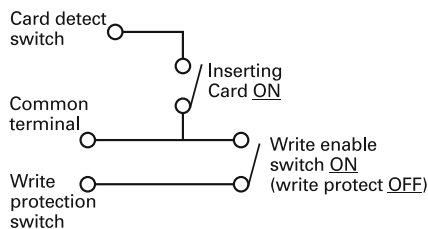

**SPECIFICATIONS**

Insulation Resistance:	1,000MΩ min. at 500V DC
Withstanding Voltage:	500V ACrms for 1 minute
Contact Resistance:	100mΩ at 1mA / 20mV max.
Voltage Rating:	250Vrms AC
Current Rating:	0.5A
Operating Temp. Range:	-25°C to +85°C
Coplanarity:	≤ 0.15mm
Mating Cycles:	10,000 (office environment)

**MATERIALS AND FINISH**

Insulator:	LCP
Plate:	Stainless Steel
Contacts:	Copper Alloy
	Contact Area = Ni-Au
	Solder Tails = Ni-Sn
Write Protection:	Copper Alloy, Ni-Au
Card Detector:	Copper Alloy, Ni-Au

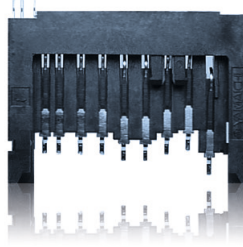

**PART NUMBER**

**FPS 009 - 3202-BL**



**FEATURES**

- Connector for both card types (SD and MMC card)
- Easy operation by manual insertion / extraction
- Short housing (20.3mm instead of 23.3mm)
- 3 step sequential contacting design
- With card retention mechanism
- With card detector and write protection
- Tape and Reel packaging
- RoHS2011/65/EU

**OUTLINE DIMENSIONS FOR FPS009-3202-BL**

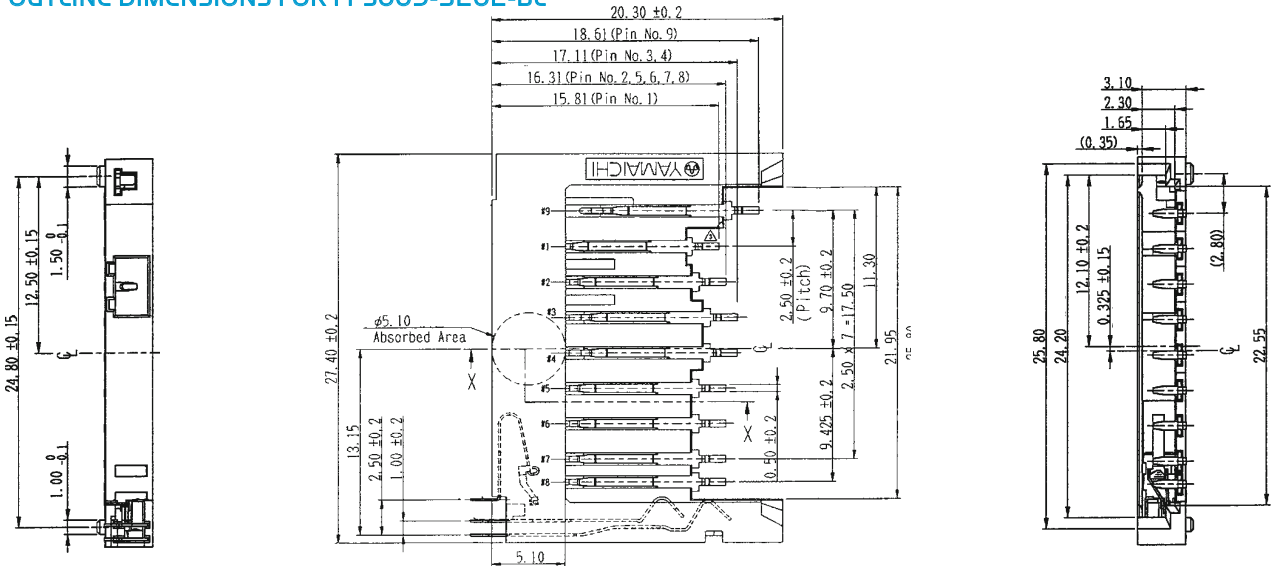

**RECOMMENDED PCB LAYOUT FPS009-3202-BL**

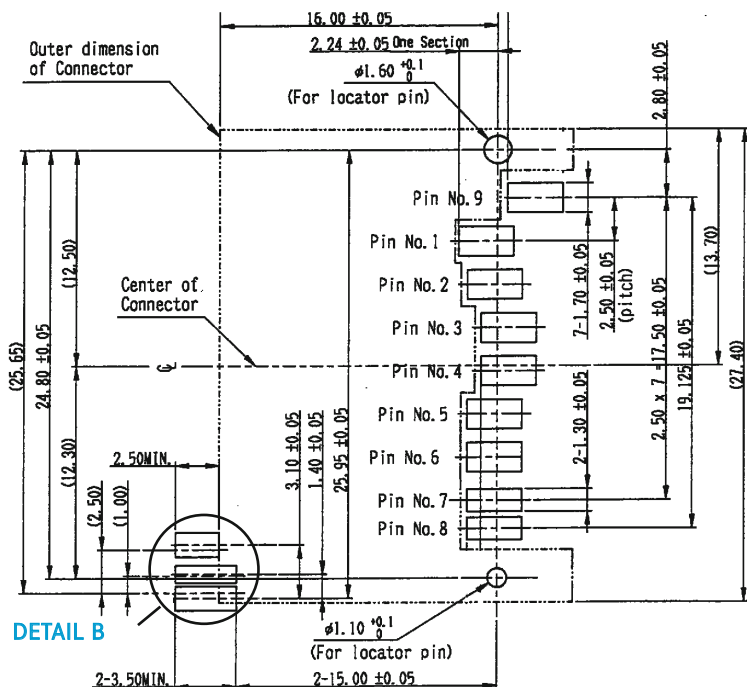

**DETAIL B**

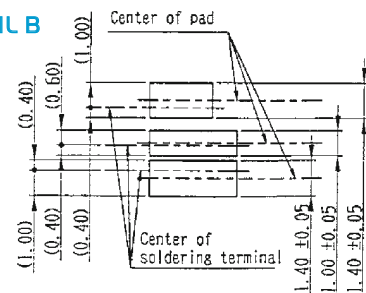

**CIRCUIT DIAGRAM FOR SWITCH**

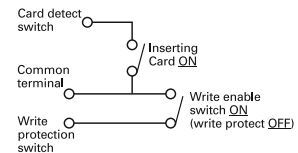

**DETAIL A (CARD DETECTOR / WRITE PROTECTOR)**

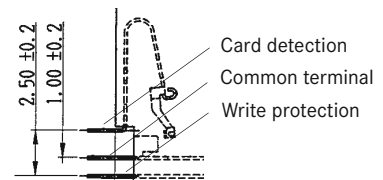

**SPECIFICATIONS**

Insulation Resistance:	1,000MΩ min. at 500V DC
Withstanding Voltage:	500V ACrms for 1 minute
Contact Resistance:	100mΩ at 1mA / 20mV max.
Voltage Rating:	5V DC
Current Rating:	0.5A max.
Operating Temp. Range:	-30°C to +85°C
Mating Cycles:	100

**MATERIALS AND FINISH**

Insulator: LCP  
Contact: Copper Alloy, Ni-Au

**FEATURES**

- Automatic locking function after insertion of SD card
- 2-point contact installation on all contact-terminals to ensure die-electric discontinuity prevention which may be caused by vibration and impact
- Zero sliding contact @100G shock (X Y Z direction)
- Metal shell cover with 4 GNDs (Solder tubs) to ensure EMI/ESD prevention performance
- RoHS2011/65/EU

**OUTLINE DIMENSIONS**

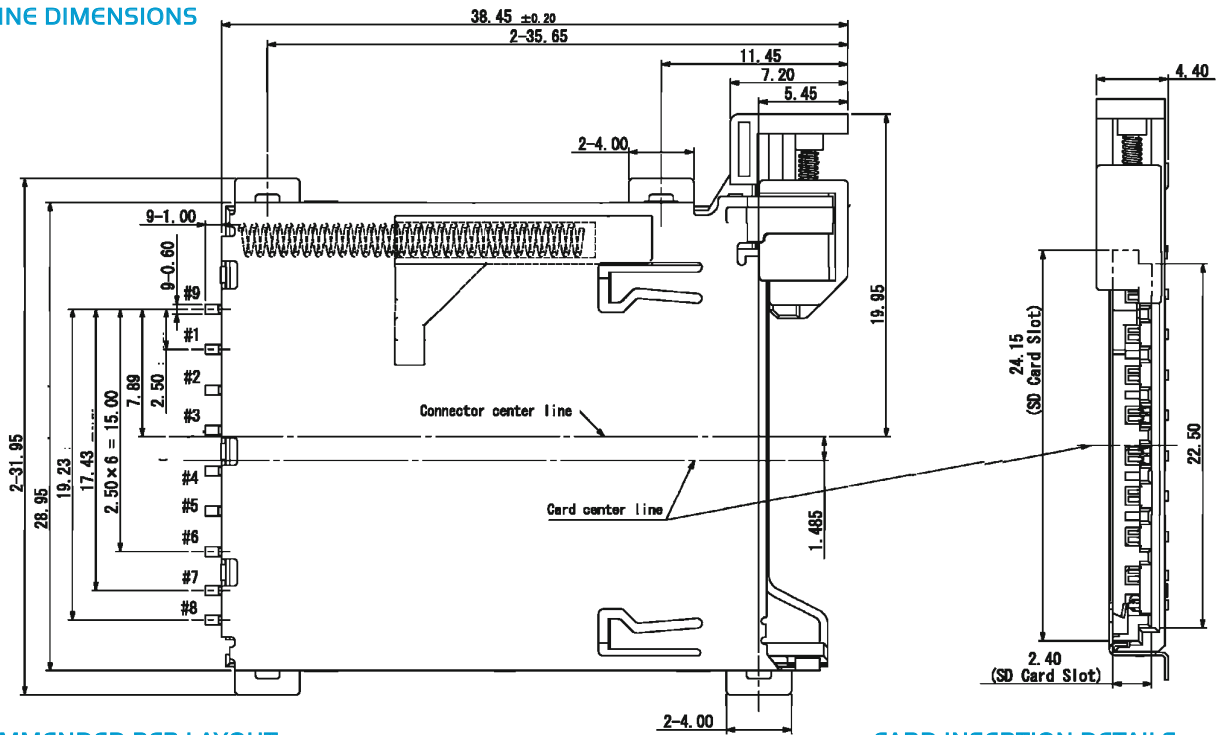

**RECOMMENDED PCB LAYOUT**

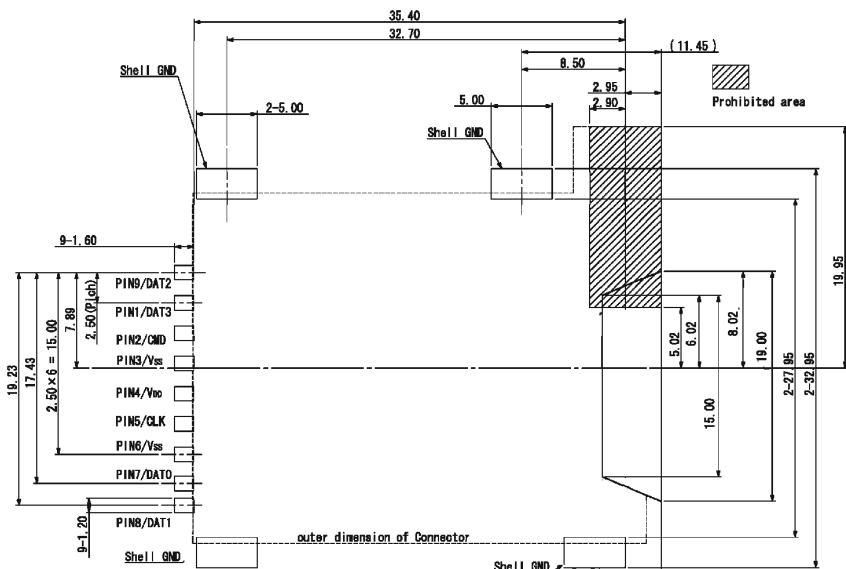

**CARD INSERTION DETAILS**

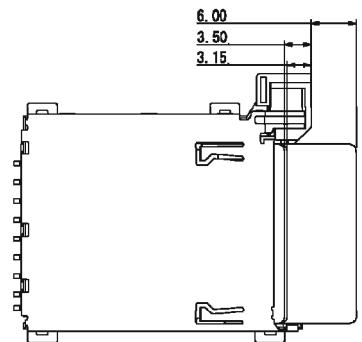

**PART NUMBER**

**FPS 009 - 4200-0 (03)**



**AUTOMOTIVE COMPLIANT**

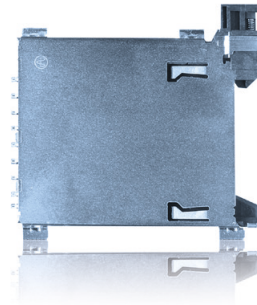



**SPECIFICATIONS**

Insulation Resistance:	1,000MΩ min. at 500V DC
Withstanding Voltage:	250V ACrms for 1 minute
Contact Resistance:	100mΩ max.
Voltage Rating:	5V DC
Current Rating:	1A max.
Operating Temp. Range:	-20°C to +60°C
Mating Cycles:	10,000

**MATERIALS AND FINISH**

Insulator:	LCP rated (UL94V-0) black
Contacts:	Phosphor Bronze at contact area
Contact Plating:	Selective Gold over Nickel
Shell:	Stainless Steel

**FEATURES**

- SD Card Reader according to Spec SD4.0
- Push/Push type with soft locking mechanism
- With card detection switch
- RoHS2011/65/EU

**OUTLINE DIMENSIONS FOR FPS017T-2000-FL-R**

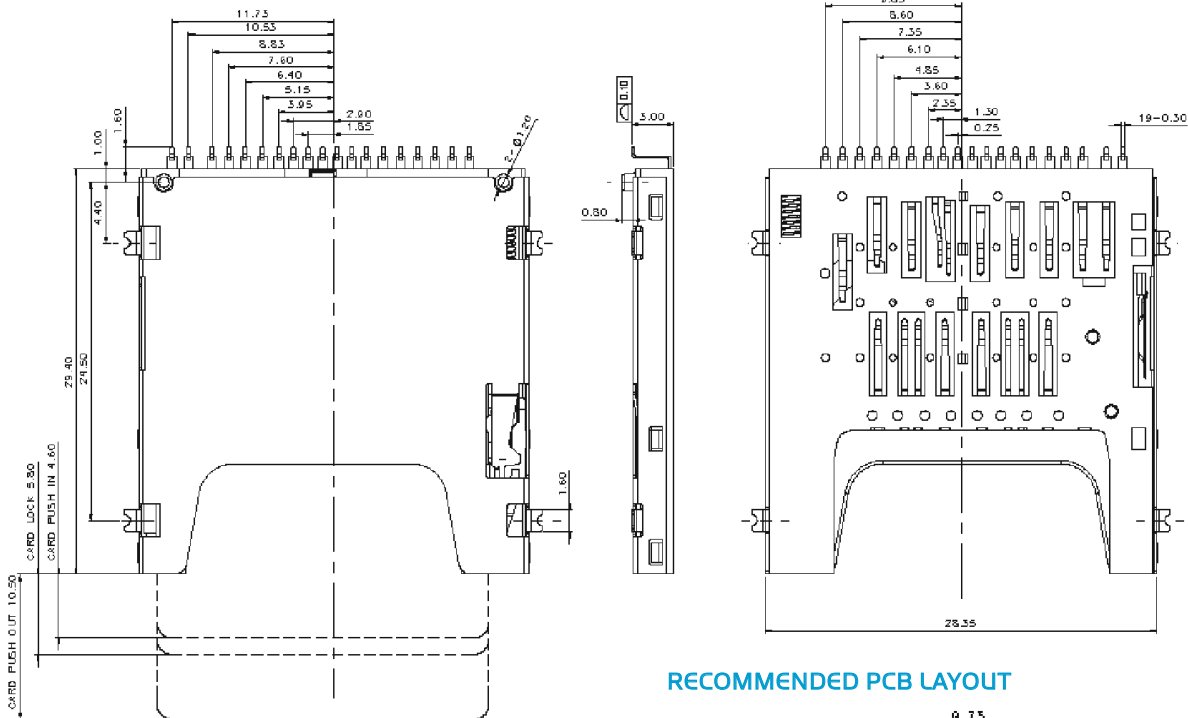

**PART NUMBER**

**FPS 017T - 1000 - FL - TRAY**

Series No.	FPS
Number of Contacts 19	017T
Design No.	1000
Contacts: Au Flash Plating	FL
Packing Type: Tray	TRAY

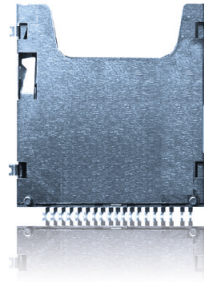

**RECOMMENDED PCB LAYOUT**

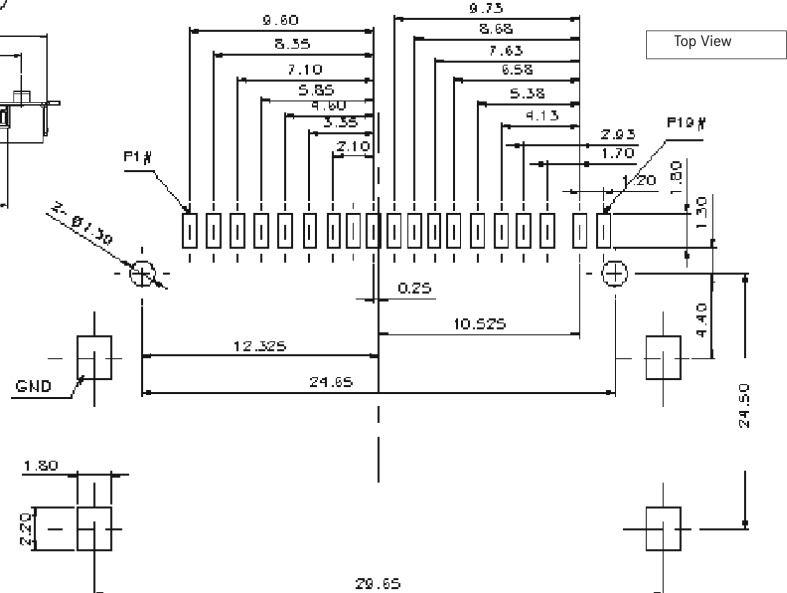

**SPECIFICATIONS**

Insulation Resistance:	1,000MΩ min. at 500V DC
Withstanding Voltage:	500V AC rms for 1 minute
Contact Resistance:	100mΩ at 1mA / 20mV max.
Voltage Rating:	50Vrms AC
Current Rating:	0.5A
Operating Temp. Range:	-25°C to +85°C
Coplanarity:	≤ 0.1mm
Reflow Temp.:	220°C for max.60 secs.,260° peak / 10 secs
Mating Cycles:	10,000 (office environment)

**MATERIALS AND FINISH**

Insulator:	LCP
Shielding Plate:	Stainless
Contacts:	Copper Alloy, Ni-Au

**FEATURES**

- Super low profile of 1.5mm
- Smooth extraction function by Push-in / Push-out of card
- Card detector and lock mechanism
- RoHS2011/65/EU
- Top Mount
- Special card brake (independent from card thickness)
- Tape & Reel packaging 1,500 pcs per reel

**OUTLINE DIMENSIONS FOR PJS008-2130-1**

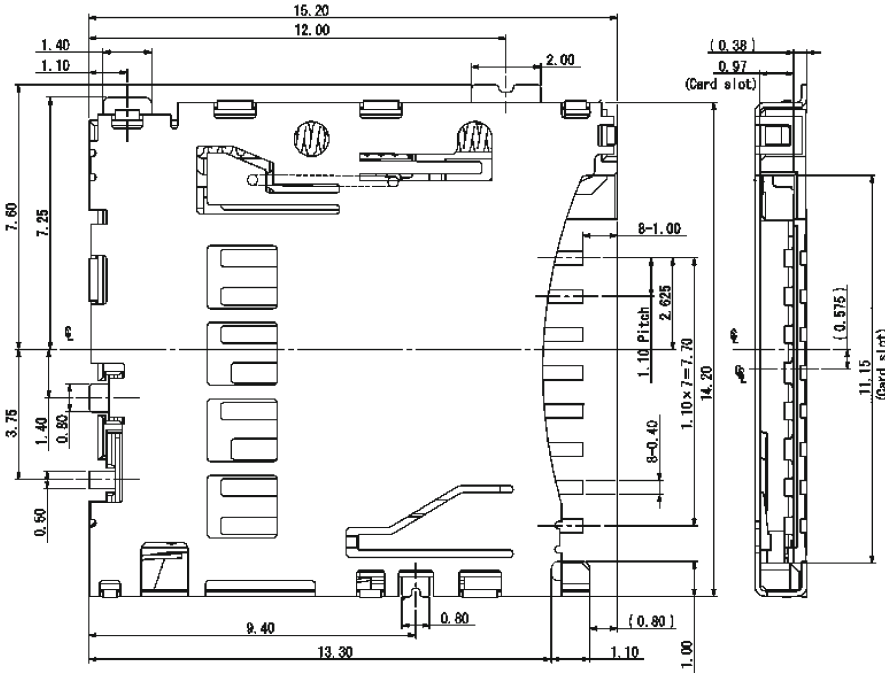

**CARD INSERTION DETAILS**

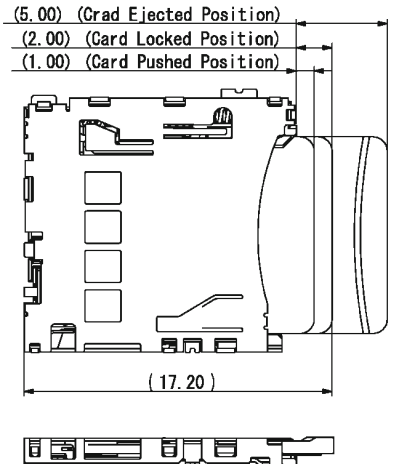

**RECOMMENDED PCB LAYOUT**

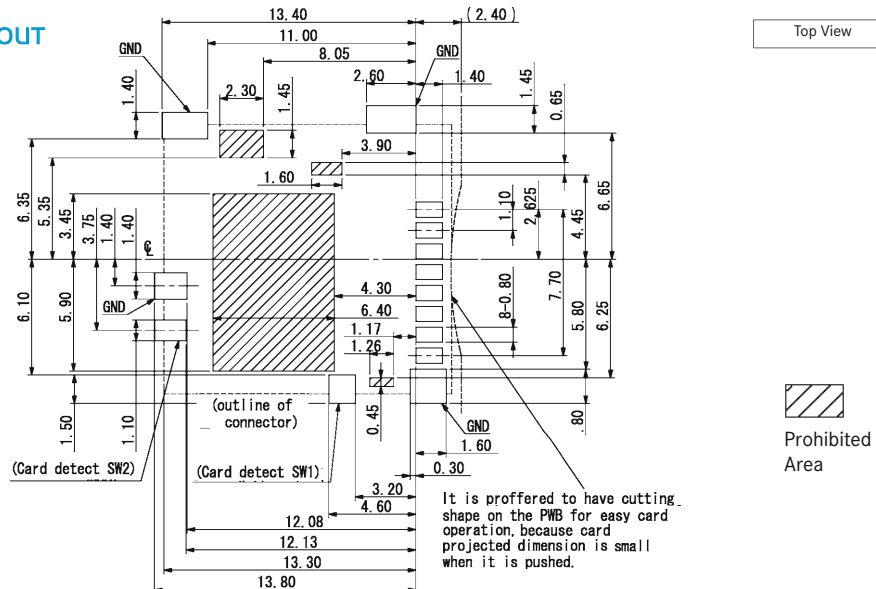

**PART NUMBER**

**PJS 008 - 2130 - 0**

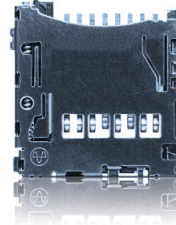
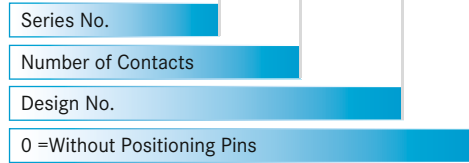

**SPECIFICATIONS**

Insulation Resistance:	500MΩ min. at 500V DC
Withstanding Voltage:	500V AC rms for 1 minute
Contact Resistance:	100mΩ at 1mA / 20mV max.
Voltage Rating:	50Vrms AC
Current Rating:	0.5A
Operating Temp. Range:	-25°C to +85°C
Coplanarity:	≤ 0.1mm
Reflow Temp.:	220°C for max.60 secs.,260° peak / 10 secs.
Mating Cycles:	10,000 (office environment)

**MATERIALS AND FINISH**

Insulator:	LCP
Shielding Plate:	Stainless
Contacts:	Copper Alloy, Ni-Au

**FEATURES**

- Super low profile of 1.5mm
- Smooth extraction function by Push-in / Push-out of card
- Card detector and lock mechanism
- Tape & Reel packaging 1,500 pcs per reel
- Top Mount
- Special card brake (independent from card thickness)
- Lubricant assisted coil spring to slow card coming out
- RoHS2011/65/EU

**OUTLINE DIMENSIONS**

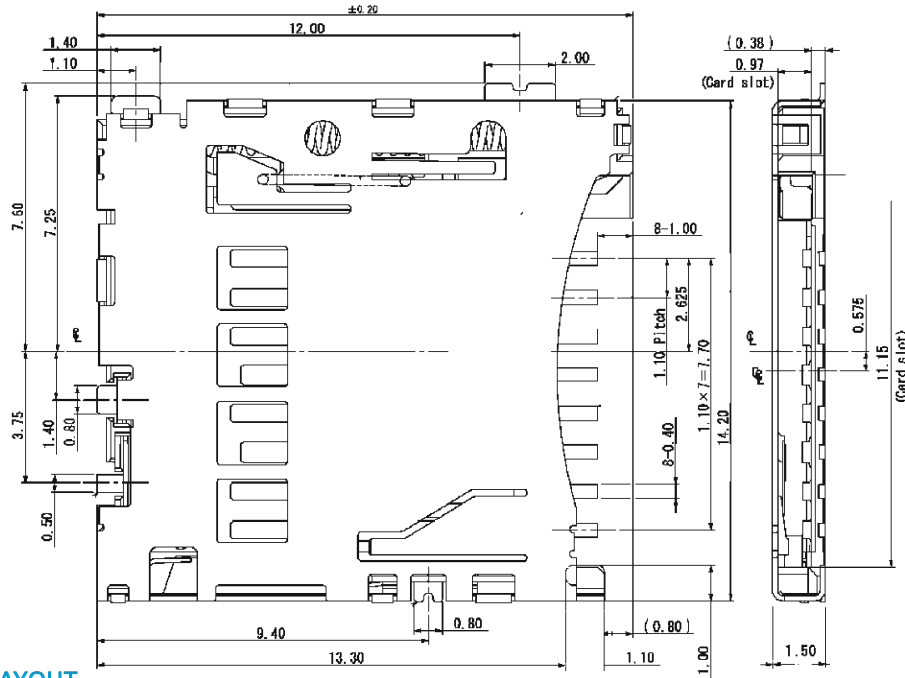

**RECOMMENDED PCB LAYOUT**

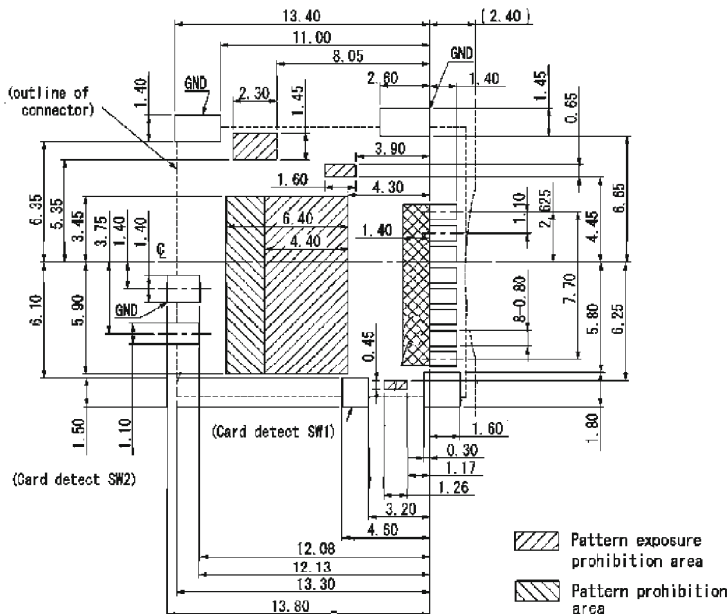

**CARD INSERTION DETAILS**

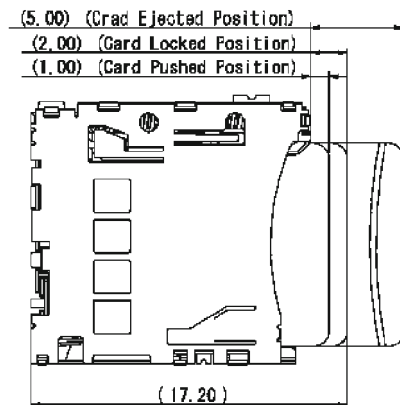

**PART NUMBER**

**PJS 008 - 2120-0**

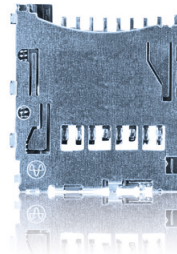

**SPECIFICATIONS**

Insulation Resistance:	1,000MΩ min. at 500V DC
Withstanding Voltage:	500V ACrms for 1 minute
Contact Resistance:	100mΩ at 1mA / 20mV max.
Voltage Rating:	50Vrms AC
Current Rating:	0.5A
Operating Temp. Range:	-25°C to +85°C
Mating Cycles:	10,000 (office environment) 3,000 (harsh environment)

**PART NUMBER**

**PJS 008 - 2004 \*-VE**

Series No.	PJS
Number of Contacts	008
Design No.	2004
0 = without Positioning Pin 1 = with Positioning Pin	*-VE

**MATERIALS AND FINISH**

Insulator:	LCP
Shielding Plate:	Stainless
Contacts:	Copper Alloy, Ni-Au

**AUTOMOTIVE  
COMPLIANT**

**FEATURES**

- Improved card detection feature, no wrong insertion of the card is possible
- Soft lock mechanism
- Card detection switch
- Tape & Reel packaging, 1,000 pcs. per reel
- RoHS2011/65/EU

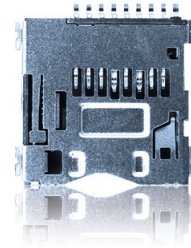

**OUTLINE DIMENSIONS FOR PJ5008-2004-0-VE**

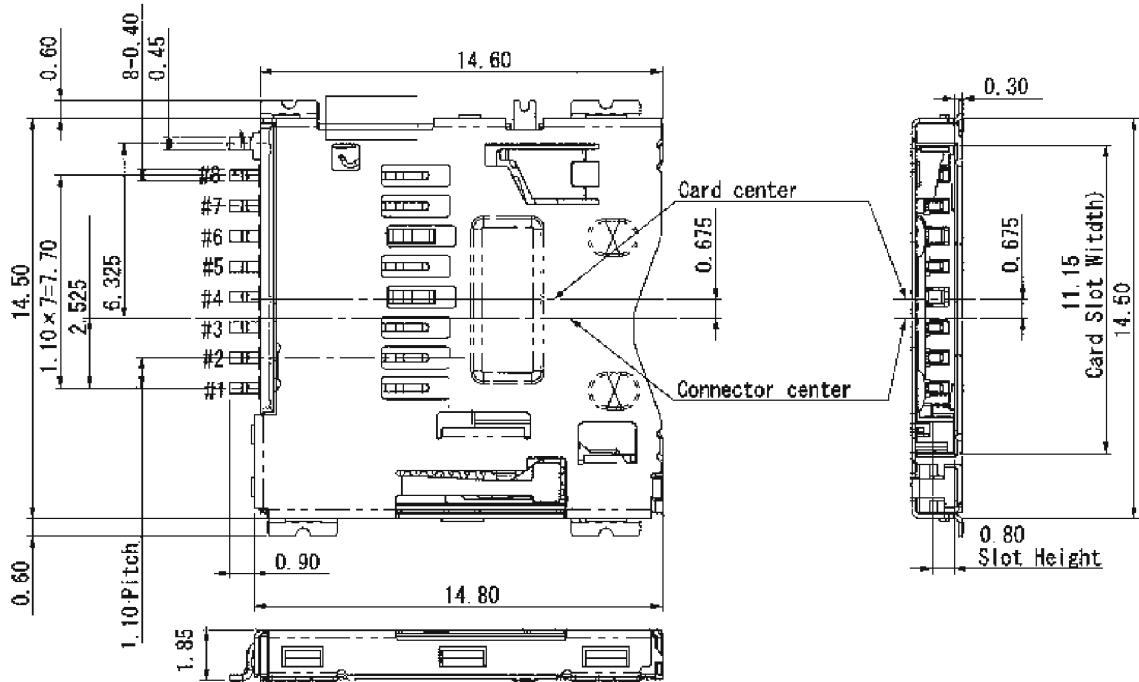

**RECOMMENDED PCB LAYOUT**

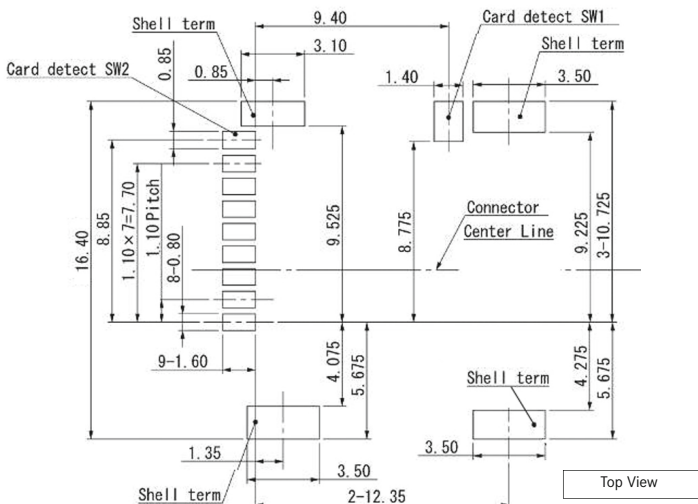

**CARD INSERTION DETAILS**

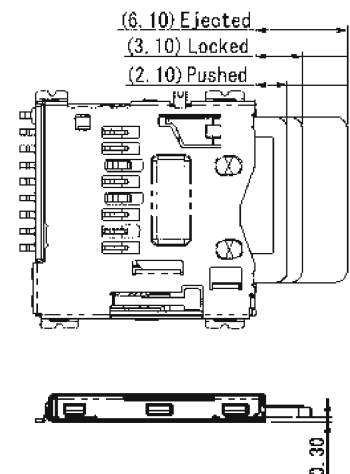

**SPECIFICATIONS**

Insulation Resistance:	1,000MΩ min. at 500V DC
Withstanding Voltage:	500V ACrms for 1 minute
Contact Resistance:	100mΩ at 1mA / 20mV max.
Voltage Rating:	50Vrms AC
Current Rating:	0.5A
Operating Temp. Range:	-25°C to +85°C
Coplanarity:	≤ 0.1mm
Reflow Temp.:	220°C for max. 60 secs., 260° peak / 10 secs.
Mating Cycles:	10,000 (office environment)

**PART NUMBER**

**PJS 008 - 2004 - 1**

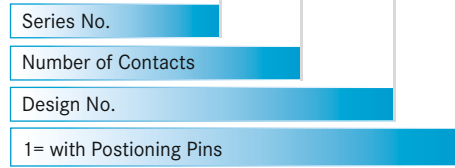

**MATERIALS AND FINISH**

Insulator:	LCP
Shielding Plate:	Stainless Steel
Contacts:	Copper Alloy, Ni-Au

**FEATURES**

- Card lock mechanism
- Smooth extraction function by Push-in /Push-out of card
- Reversed type
- RoHS2011/65/EU
- Card detector
- Tape & Reel packaging  
(PJS008-2003-0 = 1,000 / PJS008-2003-1 = 800 pcs/reel)

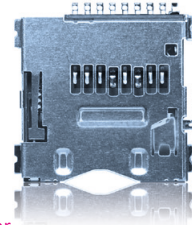

**OUTLINE DIMENSIONS FOR PJS008-2004-1**

**DANIELA BITTE PRÜFEN!!!**

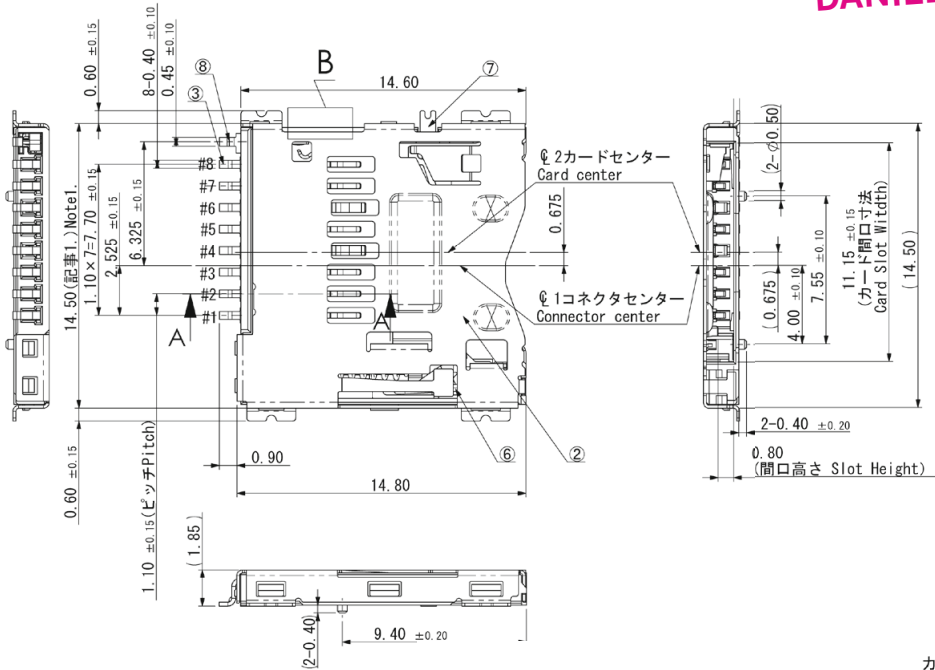

**RECOMMENDED PCB LAYOUT**

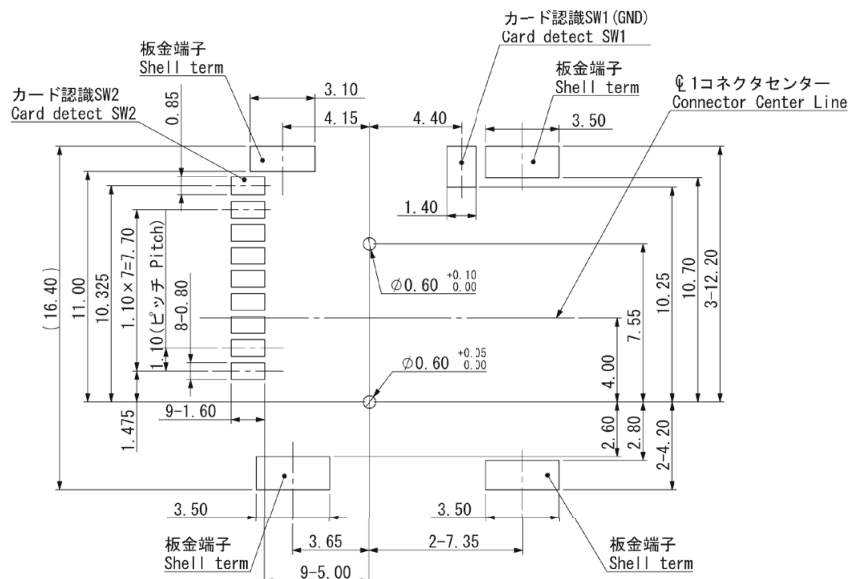

**SPECIFICATIONS**

Insulation Resistance:	1,000MΩ min. at 500V DC
Withstanding Voltage:	500V ACrms for 1 minute
Contact Resistance:	100mΩ at 1mA / 20mV max.
Voltage Rating:	50Vrms AC
Current Rating:	0.5A
Operating Temp. Range:	-25°C to +85°C
Coplanarity:	≤ 0.1mm
Reflow Temp.:	220°C for max. 60 secs., 260° peak
Mating Cycles:	10,000 (office environment)

**MATERIALS AND FINISH**

Insulator:	LCP
Shielding Plate:	Stainless
Contacts:	Copper Alloy, Ni-Au

**AUTOMOTIVE COMPLIANT**

**FEATURES**

- Strong contact reliability for enhanced vibration and shock in automotive by using dual contact
- Minimized design. W = 14.5 x L = 14.8mm
- Smooth extraction function by push-in / push-out
- With card detection
- Reverse mount
- Tape and Reel packaging 1,000 pcs. per reel
- RoHS2011/65/EU

**PART NUMBER**

**PJS 008 - 2005-0-VE**

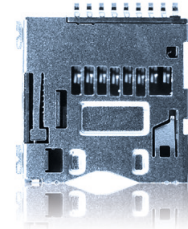

**OUTLINE DIMENSIONS FOR PJS008-2005-0-V**

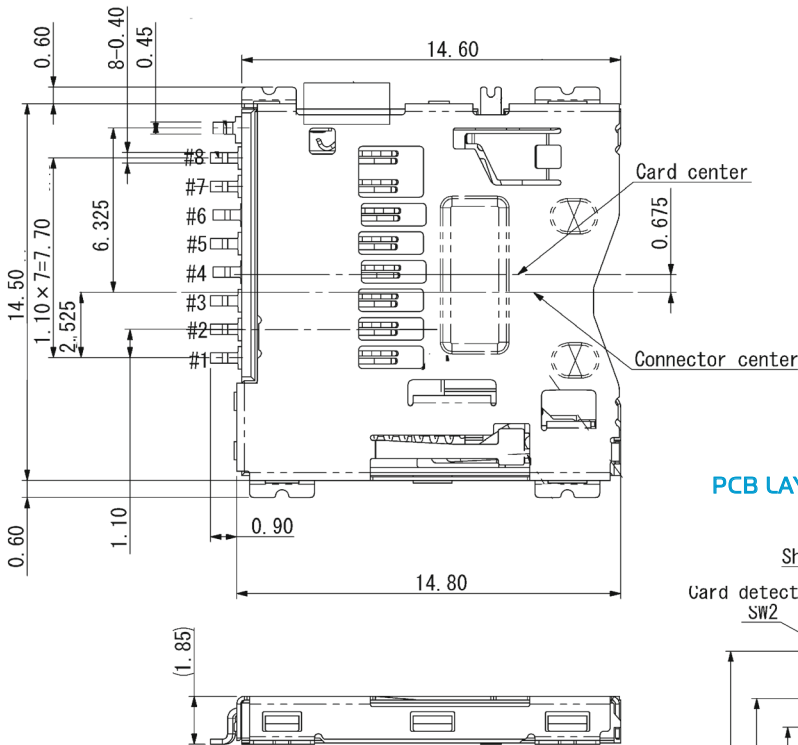

**CARD INSERTION DETAILS**

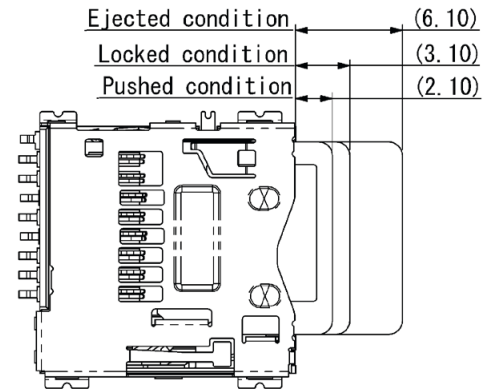

**PCB LAYOUT**

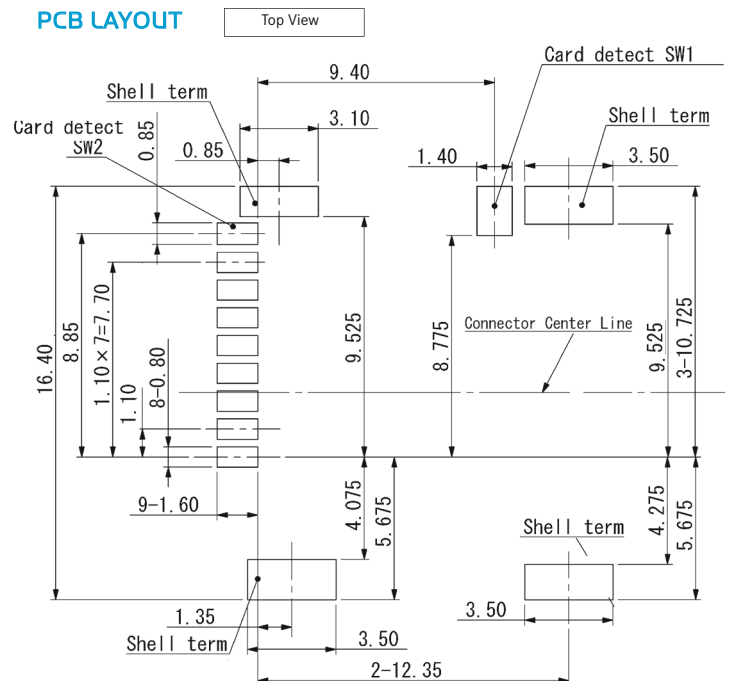

**SPECIFICATIONS**

Insulation Resistance:	1,000MΩ min. at 500V DC
Withstanding Voltage:	500V AC rms for 1 minute
Contact Resistance:	100mΩ at 1mA / 20mV max.
Voltage Rating:	5.0Vrms AC
Current Rating:	0.5A
Operating Temp. Range:	-25°C to +85°C
Coplanarity:	≤ 0.1mm
Reflow Temp.:	220°C for max.60 secs., 260° peak / 10 secs.
Mating Cycles:	30 times

**PART NUMBER**

**PJS 008 - 4100 - 0-VE**

Series No.	PJS
Number of Contacts	008
Design No.	4100
0 = without Positioning Pins	0-VE

**MATERIALS AND FINISH**

Insulator:	LCP
Shielding Plate:	Stainless
Contacts:	Copper Alloy, Ni-Au

**FEATURES**

- Two-point contact on all contacts
- Inner spring coil ensures card position also in vibration and shock conditions
- Metall shell for EMI protection
- RoHS2011/65/EU

**OUTLINE DIMENSIONS FOR PJS008-4100-0-VE**

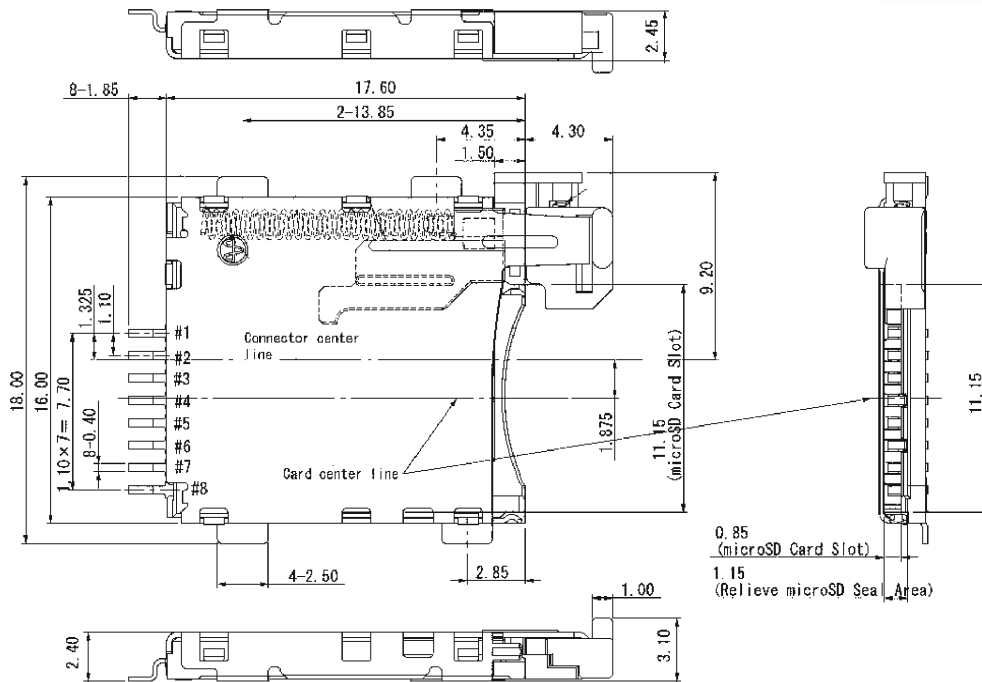

**AUTOMOTIVE COMPLIANT**

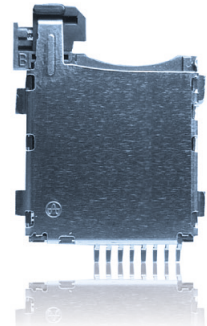

**RECOMMENDED PCB LAYOUT**

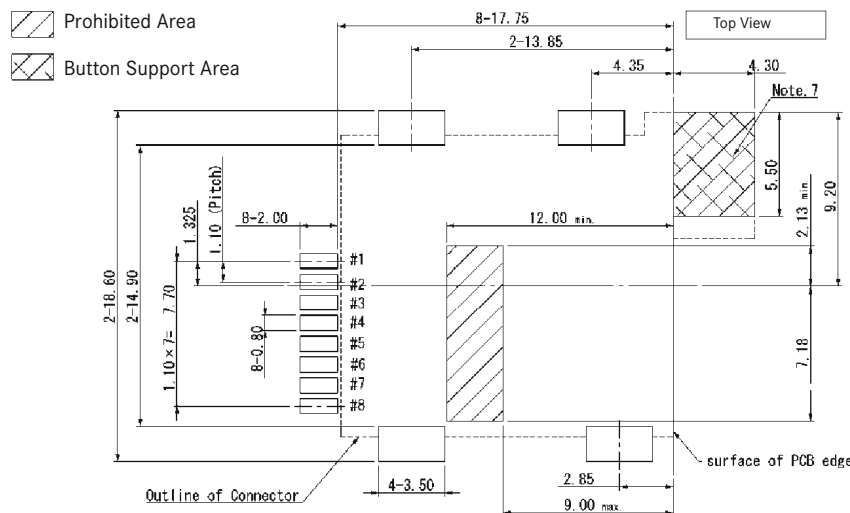

**CARD INSERTION DETAILS**

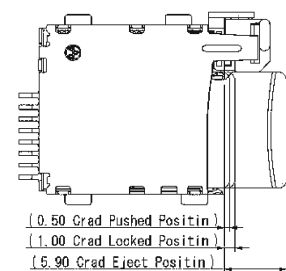



**SPECIFICATIONS**

Insulation Resistance:	500MΩ min. at 500V DC
Withstanding Voltage:	250V ACrms for 1 minute
Contact Resistance:	100mΩ max. at 10mA / 20mV max.
Current Rating:	0.5A
Voltage Rating:	5.0Vrms
Operating Temp. Range:	-55°C to +85°C
Mating Cycles:	5,000 insertions

**PART NUMBER**

**FMS006 - 2610 - 0**

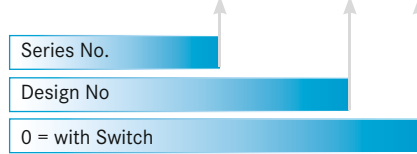

**MATERIALS AND FINISH**

Insulator:	LCP
Contact Plating:	Copper Alloy
	Contact Area: Ni-Au
	Solder Tail: Ni-Au

**AUTOMOTIVE COMPLIANT**



**FEATURES**

- Conforms to GSM11.11 standard for the European mobile phone system
- With extra locking mechanism to secure the SIM card inside the connector during shock and vibration
- Smooth extraction function by Push / Lock mechanism
- With switch
- Top Mount Type
- Tape and Reel Packaging (500 pcs./reel)
- RoHS2011/65/EU

**OUTLINE CONNECTOR DIMENSIONS**

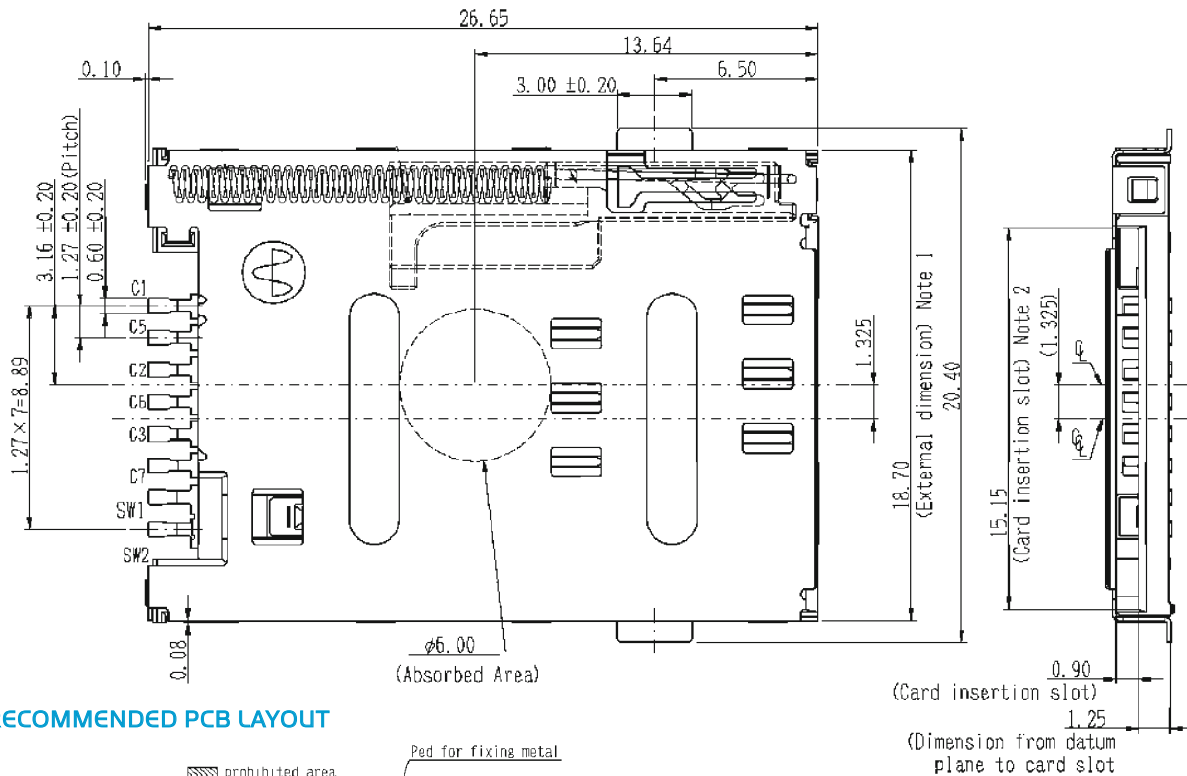

**RECOMMENDED PCB LAYOUT**

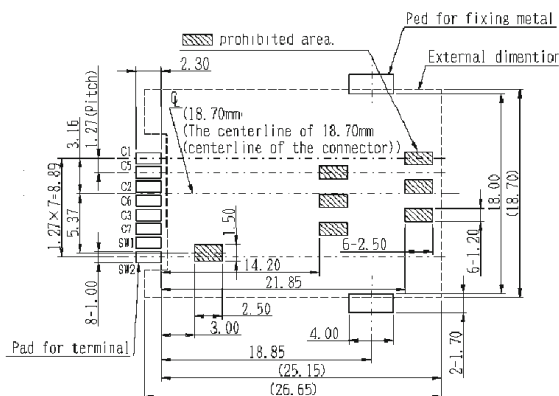

**SPECIFICATIONS**

Insulation Resistance:	500MΩ min. at 500V DC
Withstanding Voltage:	250V ACrms for 1 minute
Contact Resistance:	100mΩ max. at 1mA / 20mV max.
Current Rating:	0.5A
Voltage Rating:	5.0Vrms
Operating Temp. Range:	-55°C to +85°C
Mating Cycles:	5,000 insertions

**MATERIALS AND FINISH**

Insulator:	LCP
Contact Plating:	Copper Alloy
Contact Area:	Ni-Au

**AUTOMOTIVE COMPLIANT**

**PART NUMBER**

**FMS006 - 2620 - 0**



**FEATURES**

- Conforms to GSM11.11 standard for the European mobile phone system
- Without switch
- Smooth extraction function by Push / Push mechanism
- Tape and Reel Packaging (800 pcs./reel)
- RoHS2011/65/EU

**OUTLINE CONNECTOR DIMENSIONS**

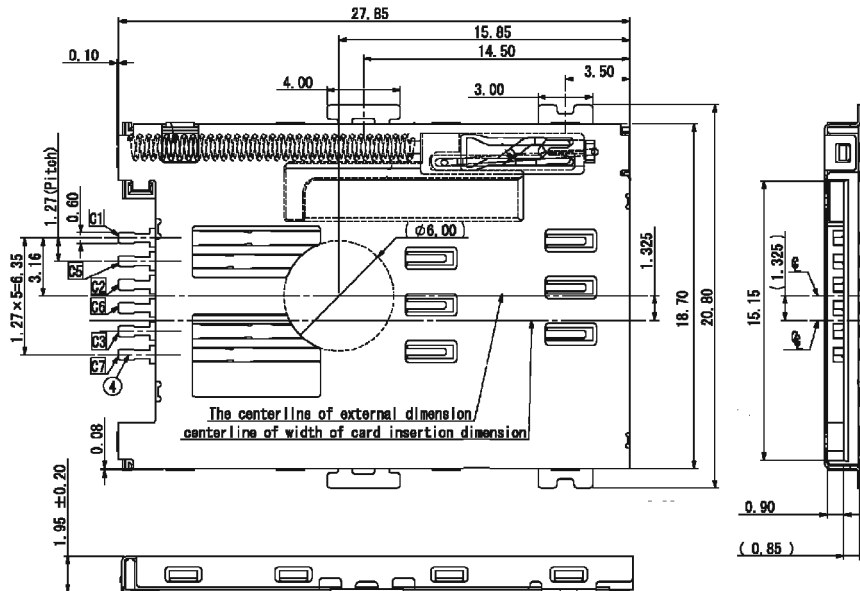

**RECOMMENDED PCB LAYOUT (MOUNTING SIDE)**

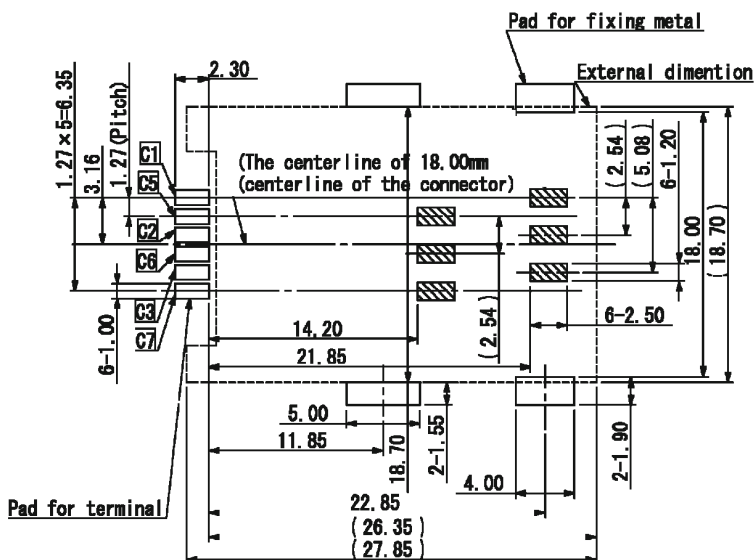

**CARD INSERTION**

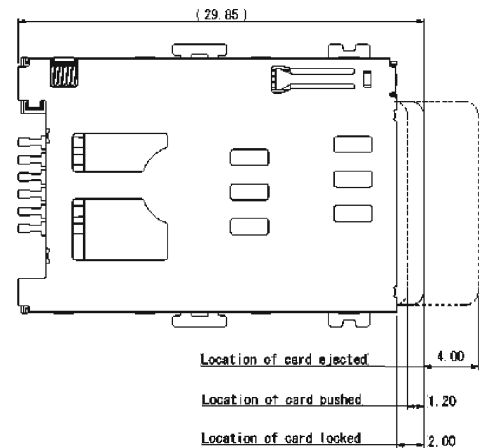

**SPECIFICATIONS**

Insulation Resistance:	500MΩ min. at 500V DC
Withstanding Voltage:	250V ACrms for 1 minute
Contact Resistance:	100mΩ max. at 10mA / 20mV max.
Current Rating:	0.5A
Voltage Rating:	5.0V AC rms
Operating Temp. Range:	-25°C to +85°C
Mating Cycles:	5,000 insertions

**MATERIALS AND FINISH**

Insulator	LCP
Shielding plate:	Stainless
Contact:	Copper Alloy, Ni-Au

**FEATURES**

- Manual type
- Static discontinuity prevention
- Tape and Reel (1,300 pcs./reel)
- Top mount
- Super low profile design ht. = 1.40mm
- RoHS2011/65/EU

**PART NUMBER**

**FMS006 - 5100-0**

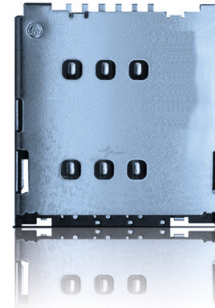

**OUTLINE CONNECTOR DIMENSIONS (TOP VIEW)**

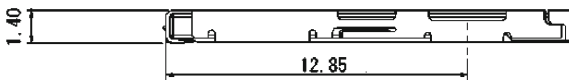
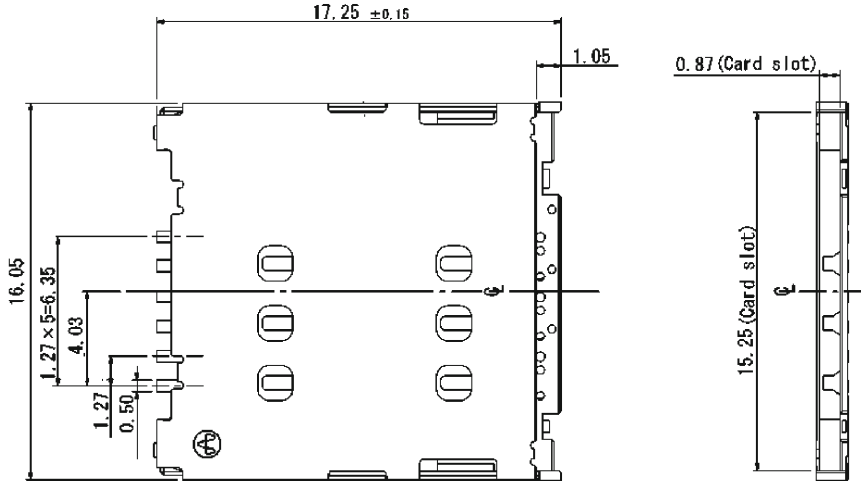

**CARD INSERTION**

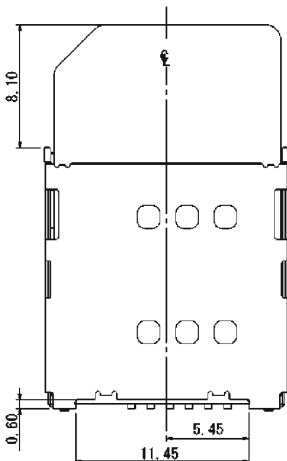

**RECOMMENDED PCB LAYOUT**

(mounting side)

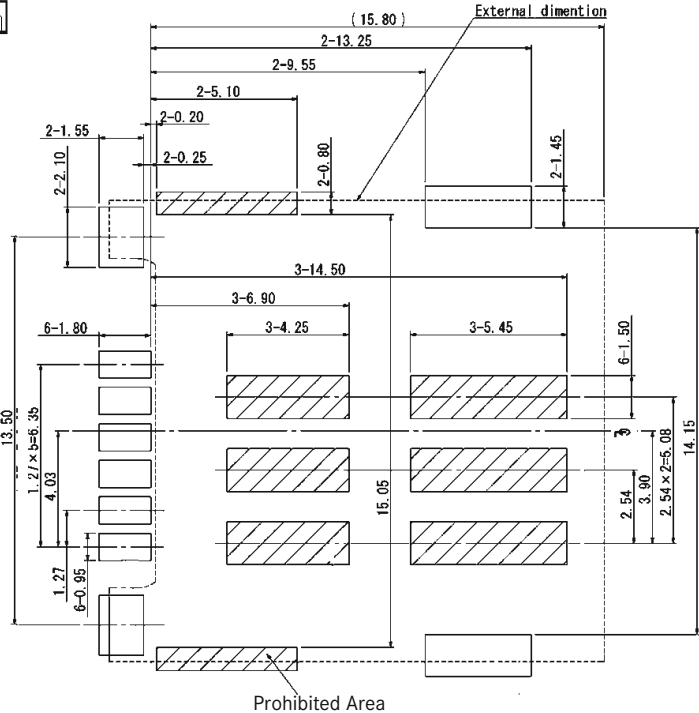





**SPECIFICATIONS**

Insulation Resistance:	500MΩ min. at 500V DC
Withstanding Voltage:	250V ACrms for 1 minute
Contact Resistance:	100mΩ max. at 1mA / 20mV max. Current
Rating:	0.5A
Voltage Rating:	5V AC rms
Operating Temp. Range:	-25°C to +85°C
Mating Cycles:	5,000 insertions

**PART NUMBER**

**FMS006 - 3710 - 0**



**PART NUMBER TRAY**

**FMA006-3700 - 0**

**MATERIALS AND FINISH**

Insulator	LCP
Shielding plate:	Stainless
Contact:	Copper Alloy, Ni-Au

**FEATURES**

- Low profile 1.65mm
- Removable Tray
- Packaging Card Reader: Tape and Reel (1,200 pcs./Tape & Reel)
- Packaging for Trays: Tray (400 pcs.)
- RoHS2011/65/EU

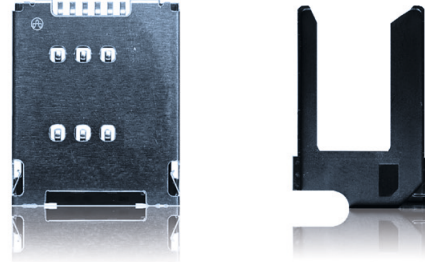

**OUTLINE CONNECTOR DIMENSIONS (TOP VIEW)**

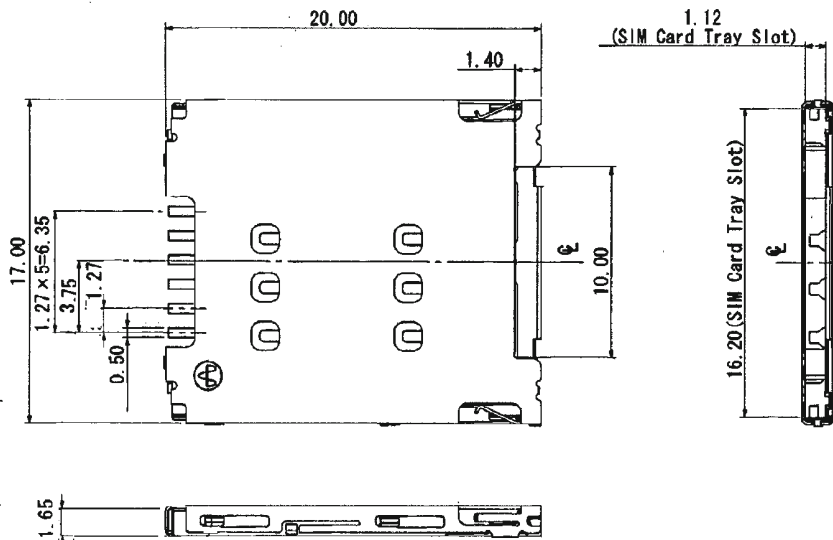

**RECOMMENDED PCB LAYOUT (MOUNTING SIDE)**

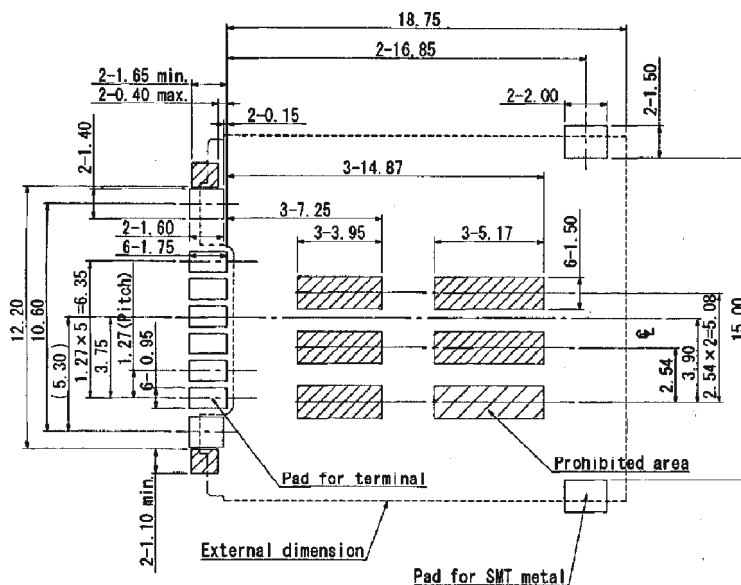

**SPECIFICATIONS**

Insulation Resistance:	500MΩ min. at 500V DC
Withstanding Voltage:	250V ACrms for 1 minute
Contact Resistance:	100mΩ max. at 1mA / 20mV max. Current
Rating:	0.5A
Voltage Rating:	5V AC rms
Operating Temp. Range:	-25°C to +85°C
Mating Cycles:	5,000 insertions

**PART NUMBER**

**FMS006 - 3810 - 0**



**PART NUMBER TRAY**

**FMA006-3800-0**

**MATERIALS AND FINISH**

Insulator	LCP
Shielding plate:	Stainless
Contact:	Copper Alloy, Ni-Au

**FEATURES**

- Low profile 1.65mm
- Removeable Tray
- Packaging Card Reader: Tape and Reel (1,200 pcs./Tape & Reel)
- Packaging for Trays: Tray (400 pcs.)
- RoHS2011/65/EU

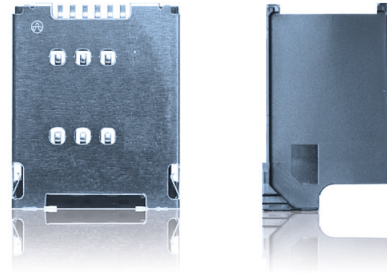

**OUTLINE CONNECTOR DIMENSIONS (TOP VIEW)**

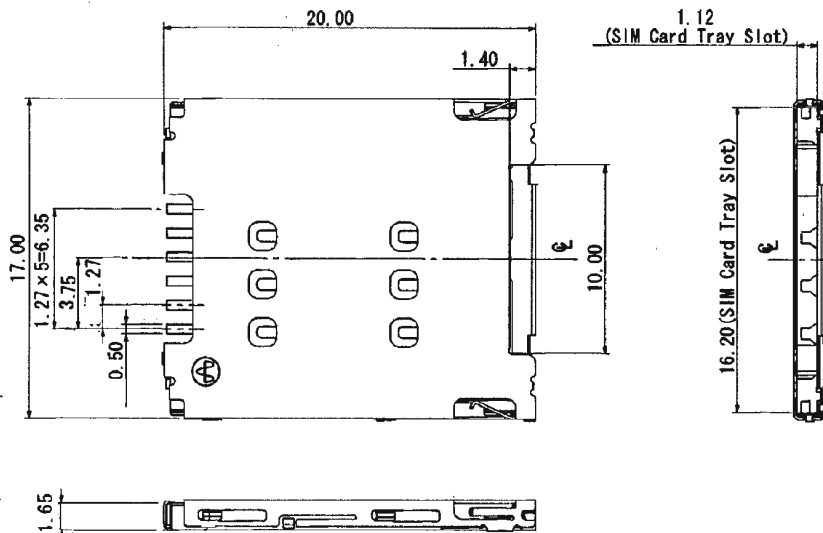

**RECOMMENDED PCB LAYOUT (MOUNTING SIDE)**

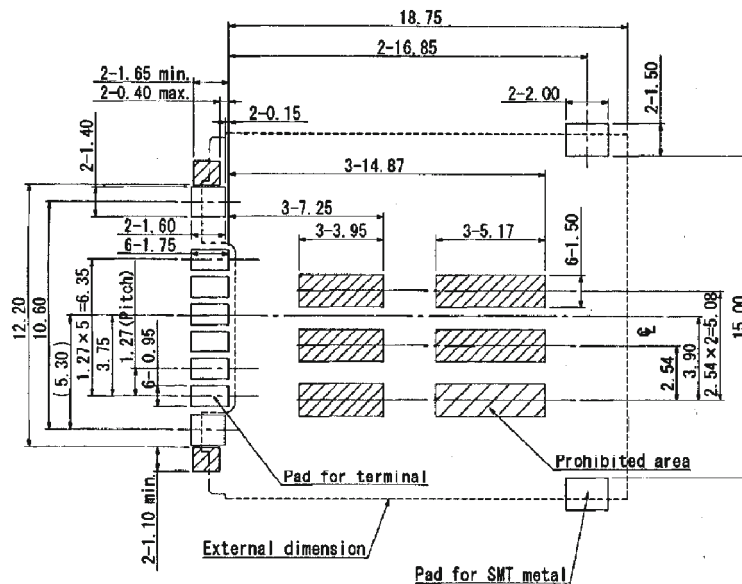

**SPECIFICATIONS**

Insulation Resistance:	1,000MΩ min. at 500V DC
Withstanding Voltage:	500V ACrms for 1 minute
Contact Resistance:	100mΩ max. at 1mA / 20mV max.
Current Rating:	0.5A
Voltage Rating:	5.0Vrms
Operating Temp. Range:	-55°C to +85°C
Mating Cycles:	5,000 insertions

**MATERIALS AND FINISH**

Insulator: LCP  
Contact: Copper Alloy, Ni-Au

**FEATURES**

- 8 SIM contacts
- Super low profile of 1.5mm
- Top Mount for SMT soldering
- Smooth extraction function by Push/Push mechanism
- With switch
- Tape & Reel packaging 1,000 pcs per reel
- RoHS2011/65/EU

**PART NUMBER**

**FMS008 - 6001 - 0**



**AUTOMOTIVE COMPLIANT**

**OUTLINE DIMENSIONS FOR FMS008-6001-0**

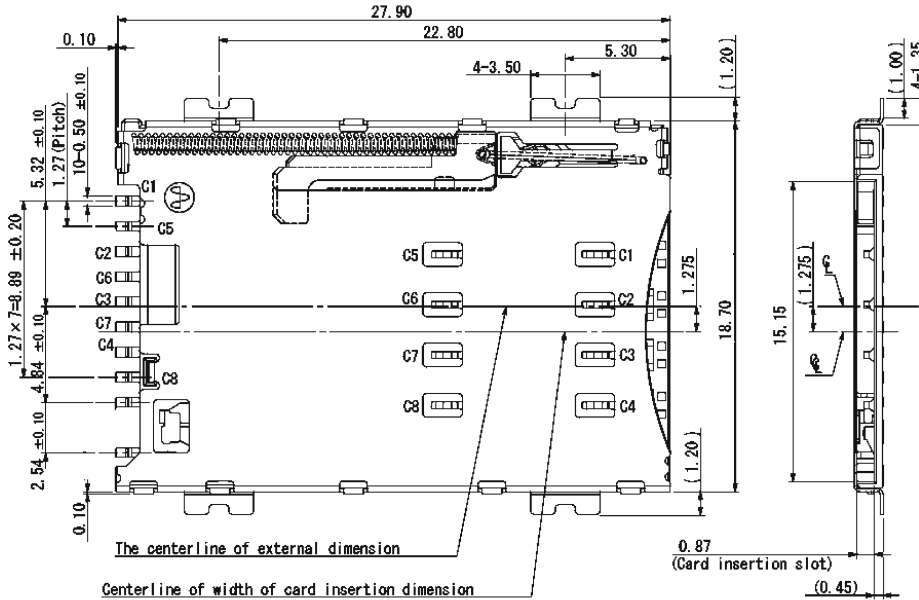

**RECOMMENDED PCB LAYOUT**

Top View

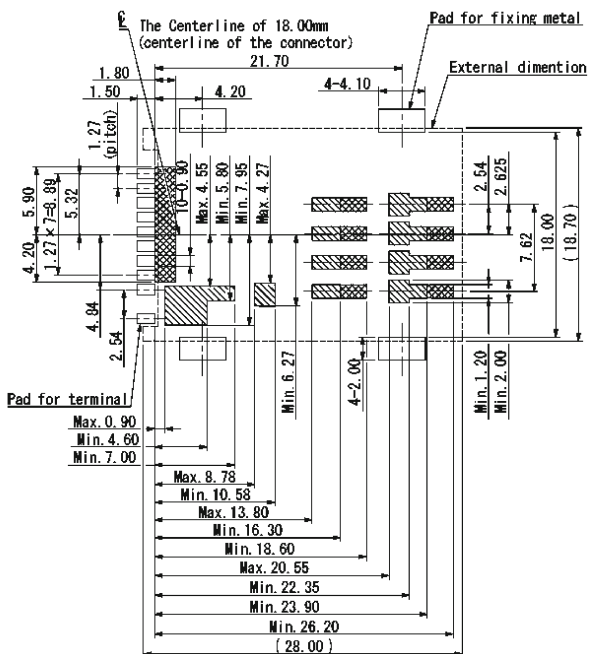

**CARD INSERTION DETAILS**

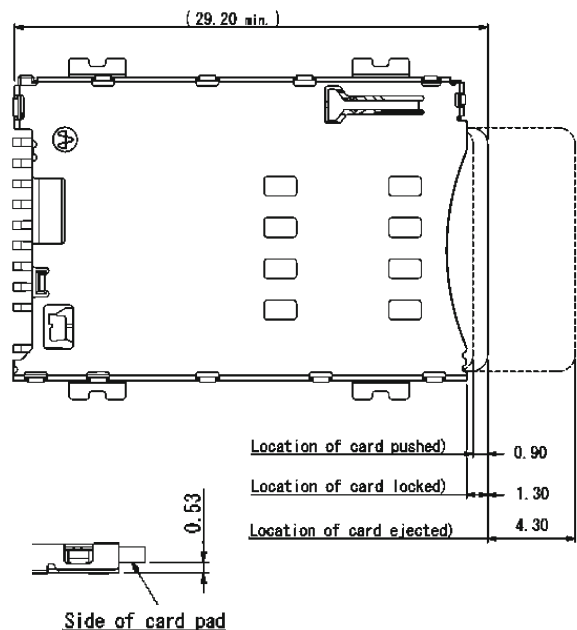

**SPECIFICATIONS**

Insulation Resistance:	500MΩ min. at 500V DC
Withstanding Voltage:	500V ACrms for 1 minute
Contact Resistance:	100mΩ max. at 1mA / 20mV max.
Current Rating:	0.5A
Voltage Rating:	5.0Vrms
Operating Temp. Range:	-25°C to +85°C
Mating Cycles:	5,000 insertions

**PART NUMBER**

**FUS006 - 8500-0**



**AUTOMOTIVE COMPLIANT**



**MATERIALS AND FINISH**

Insulator: LCP  
Contact: Copper Alloy, Ni-Au

**FEATURES**

- Top mount type
- Super low profile ht. = 1.34mm max.
- EMI Protection (6 point GND)
- Tape and Reel packaging (1,000 pcs./reel)
- RoHS2011/65/EU

**OUTLINE CONNECTOR DIMENSIONS**

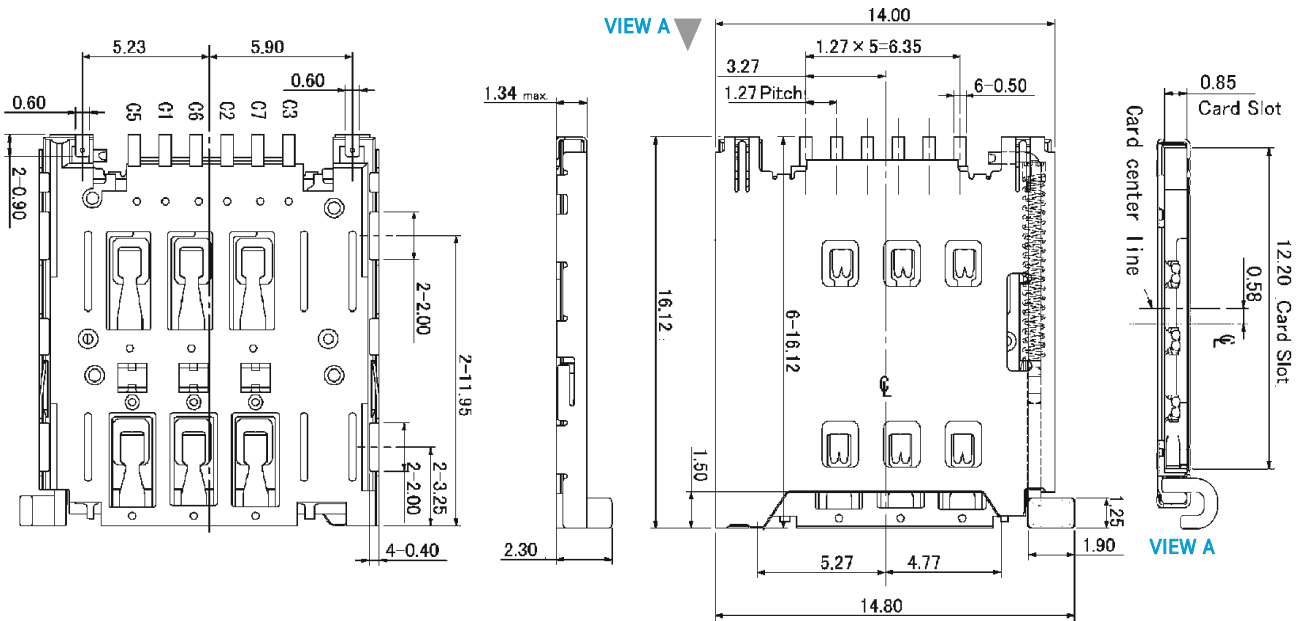

**CARD INSERTION**

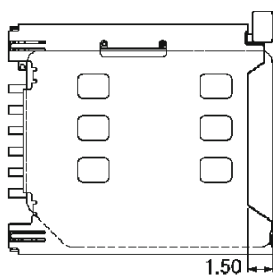

Card locked position

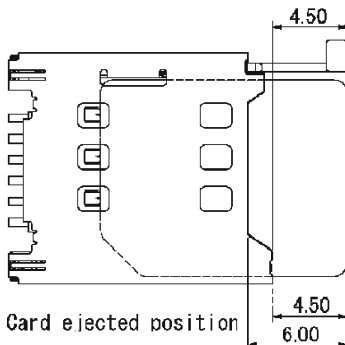

Card ejected position

**RECOMMENDED PCB LAYOUT**

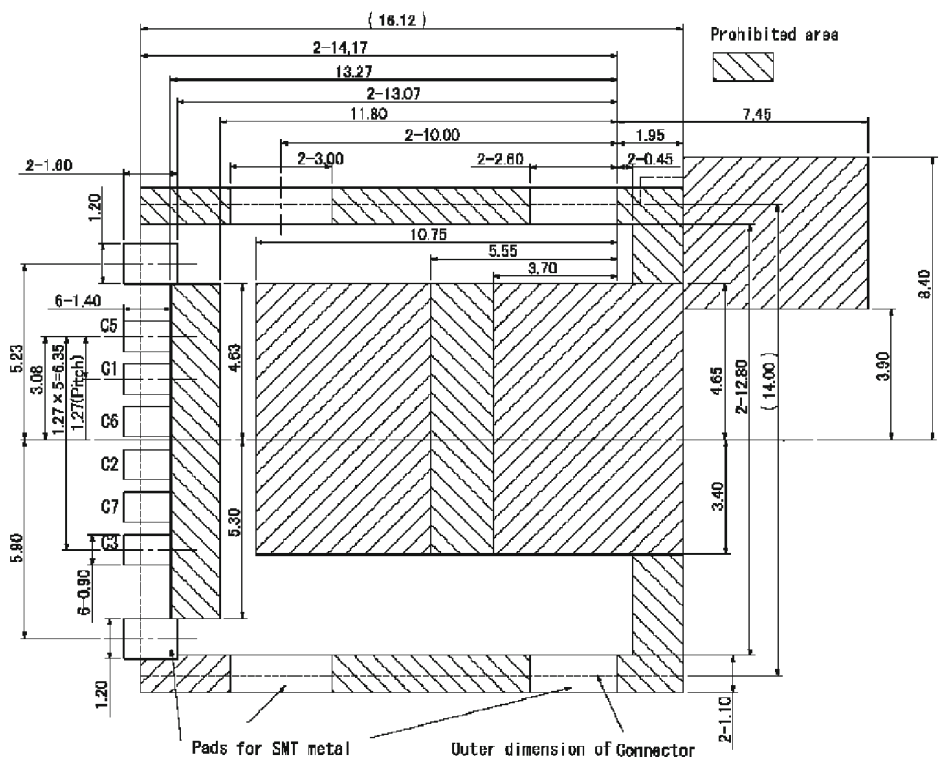

**SPECIFICATIONS**

Insulation Resistance:	500MΩ min.
Withstanding Voltage:	250V ACrms for 1 minute
Contact Resistance:	100mΩ max. at 1mA / 20mV max.
Current Rating:	0.5A
Voltage Rating:	5.0Vrms
Operating Temp. Range:	-25°C to +85°C
Mating Cycles:	5,000 insertions

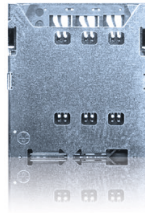

**PART NUMBER (WITHOUT TRAY)**

**FUS006 - 3210-0**



**PART NUMBER TRAY TYPE FOR MICROSIM**

**FUA006 - 3210-0**



**MATERIALS AND FINISH**

Insulator: LCP  
 Contact : Copper Alloy,  
 t = 0.12, Ni-Au

**FEATURES**

- Reversed mount type
- One Card reader usable with two different trays for Nano or Micro Sim Cards
- Super low profile 1.15mm height
- RoHS2011/65/EU

**OUTLINE CONNECTOR DIMENSIONS**

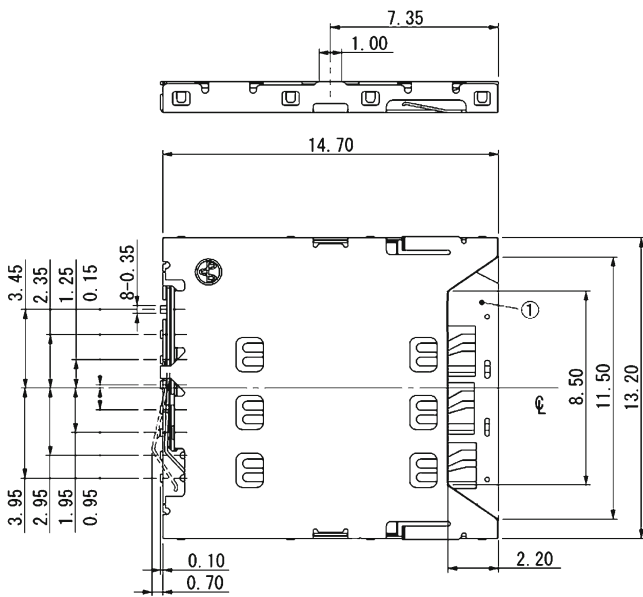

1.15 (Card Tray Slot)

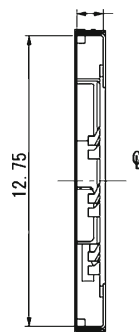

**PART NUMBER TRAY TYPE FOR NANOSIM**

**FUA006 - 3220-0**

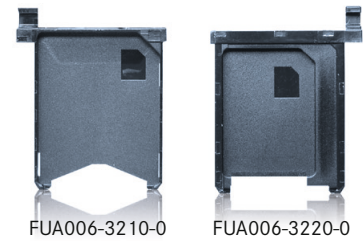

**TRAY FUA3210-0, FOR MICROSIM**

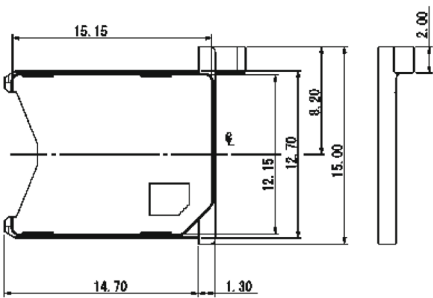

**TRAY FUA3220-0, FOR NANOSIM**

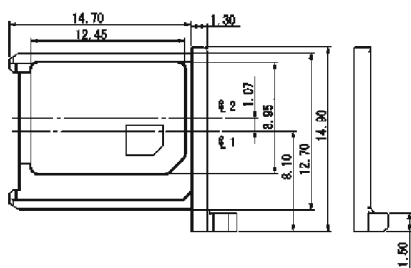

**RECOMMENDED PCB LAYOUT**

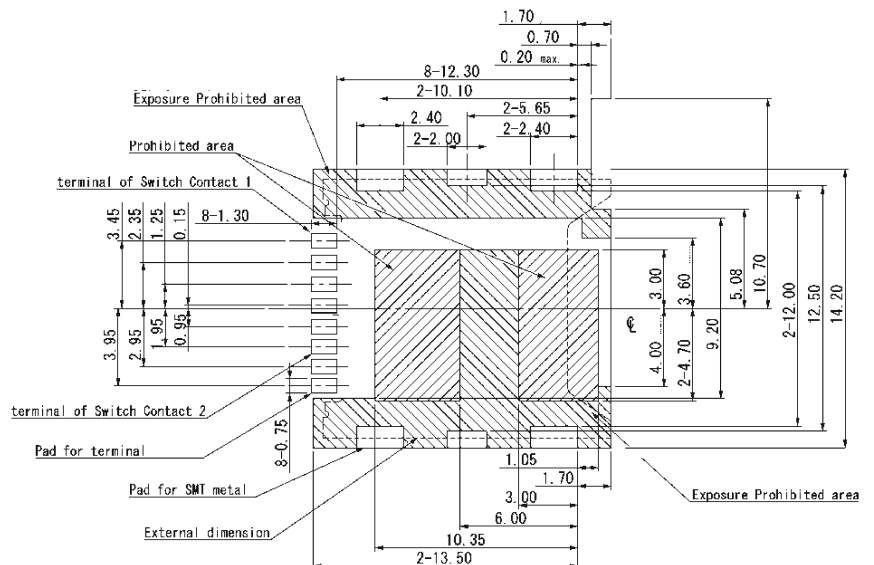



**SPECIFICATIONS**

Insulation Resistance: 1000MΩ at 500V DC  
 Withstanding Voltage: 500Vrms  
 Current Rating: 0.5A  
 Operating Temp. Range: -20°C to +90°C  
 Reflow Solder Temp.: 220°C min./sec.  
 260°C peak  
 Mating Cycles: 10,000 times

**MATERIALS AND FINISH**

Insulator: LCP, glass filled (UL94V-0)  
 SMT Metal: Brass, pure Sn  
 Push Button: Glass reinforced PBT (UL94V-0)  
 Cover: Stainless Steel  
 Contacts: Brass  
 Plating: Contacts - Gold (15μ") over Nickel (40μ")  
 Solder Tails - pure Sn

**FEATURES**

- Adapter for Compact Flash Card Type I
- With push button ejector (optional)
- RoHS2011/65/EU

**OUTLINE DIMENSIONS (WITHOUT EJECTOR)**

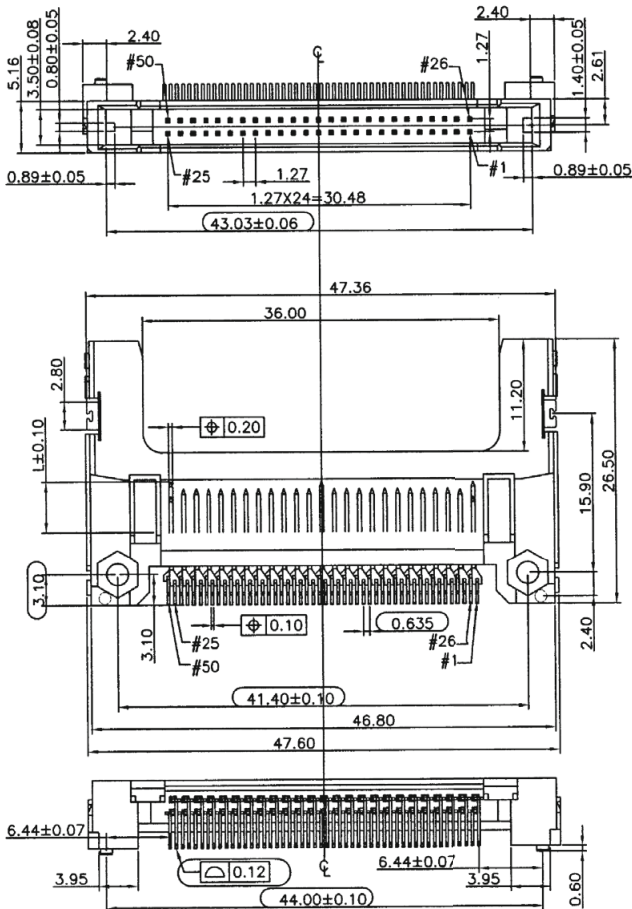

**PART NUMBER**

**CF 050P - 003 - \* \* DS**

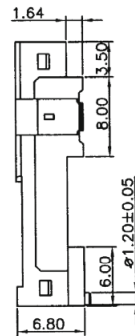
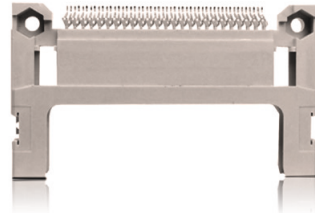
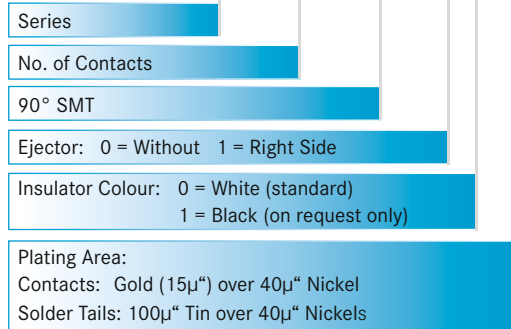

**RECOMMENDED PCB LAYOUT AND MOUNTING AREA**

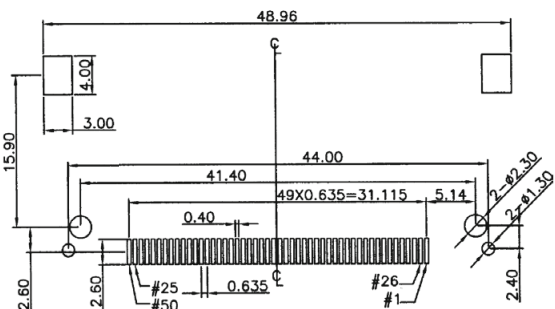

**SPECIFICATIONS**

Insulation Resistance: 1000MΩ at 500V DC  
 Withstanding Voltage: 500Vrms  
 Current Rating: 0.5A  
 Operating Temp. Range: -55°C to +85°C  
 Reflow Solder Temp.: 220°C min. / 60 sec, 260°C peak  
 Mating Cycles: 10,000 times

**MATERIALS AND FINISH**

Insulator: LCP, glass filled (UL94V-0)  
 SMT Metal: Brass, pure Sn  
 Push Button: Glass reinforced PBT (UL94V-0)  
 Cover: Stainless Steel  
 Contacts: Brass  
 Plating: Contacts - Gold (15μ") over Nickel (40μ")  
 Solder Tails - pure Sn

**FEATURES**

- Adapter for Compact Flash Card Type I and II
- With push button ejector (optional)
- RoHS2011/65/EU)

**PART NUMBER**

**CF 050 P2 - \* 0 3 - \* 0 - DS 3**

Series	CF
No. of Contacts	050
Stand-off Height: 0 = without 1 = 2.20mm	P2
0 = Top Mounted on PCB	*
3 = 90° SMT	03
Ejector: 0 = Without 1 = Right Side	*
Plating Area:	
Contacts: Gold (15μ") over 40μ" Nickel	
Solder Tails: 100μ" Tin over 40μ" Nickel	
No Mark = Without Foil	
3 = Mylar Foil	DS 3

**OUTLINE DIMENSIONS (NO STAND-OFF)**

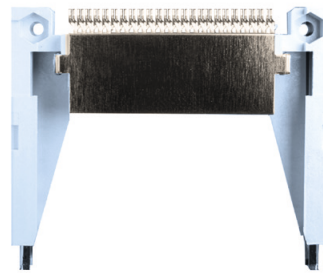
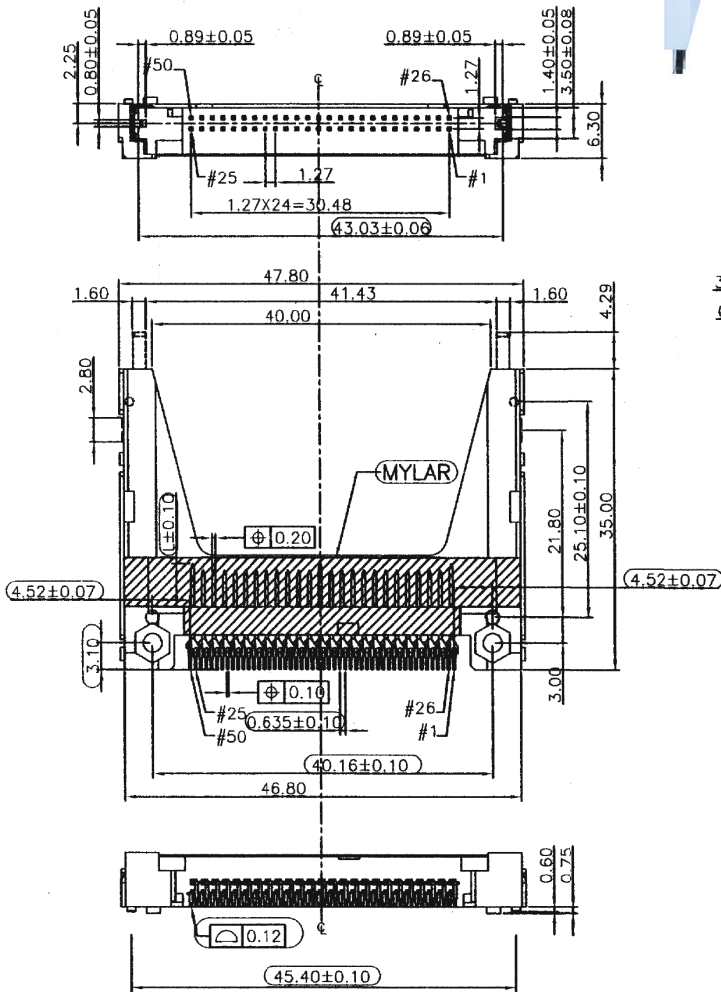

**RECOMMENDED PCB LAYOUT**

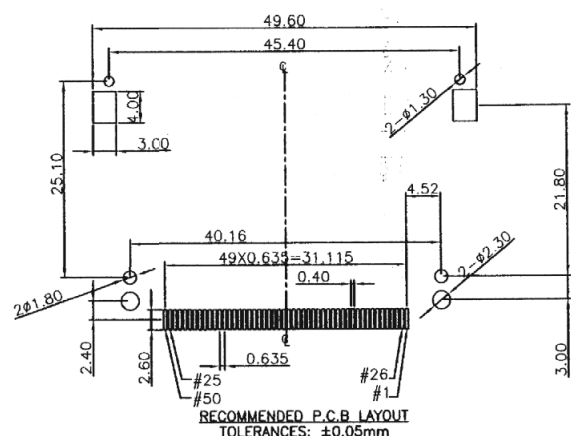

**SPECIFICATIONS**

Insulation Resistance:	1000MΩ at 500V DC
Withstanding Voltage:	500Vrms
Current Rating:	1A AC/DC max.
Contact Resistance:	40mΩ max. at 20mV max.
Operating Temp. Range:	-55°C to +85°C
Reflow Solder Temp.:	220°C min. / 60 sec, 260°C peak
Mating Cycles:	10,000 times

**MATERIALS AND FINISH**

Insulator:	LCP, glass filled (UL94V-0)
SMT Metal:	Brass, pure Sn
Push Button:	Glass reinforced PBT (UL94V-0)
Cover:	Stainless Steel
Contacts:	Brass
Plating:	Contacts - Gold (15μ") over Nickel (40μ") Solder Tails - pure Sn

**FEATURES**

- Adapter for Compact Flash Card type I and II
- Reversed type, for assembly underneath the PCB
- RoHS2011/65/EU

**OUTLINE DIMENSIONS**

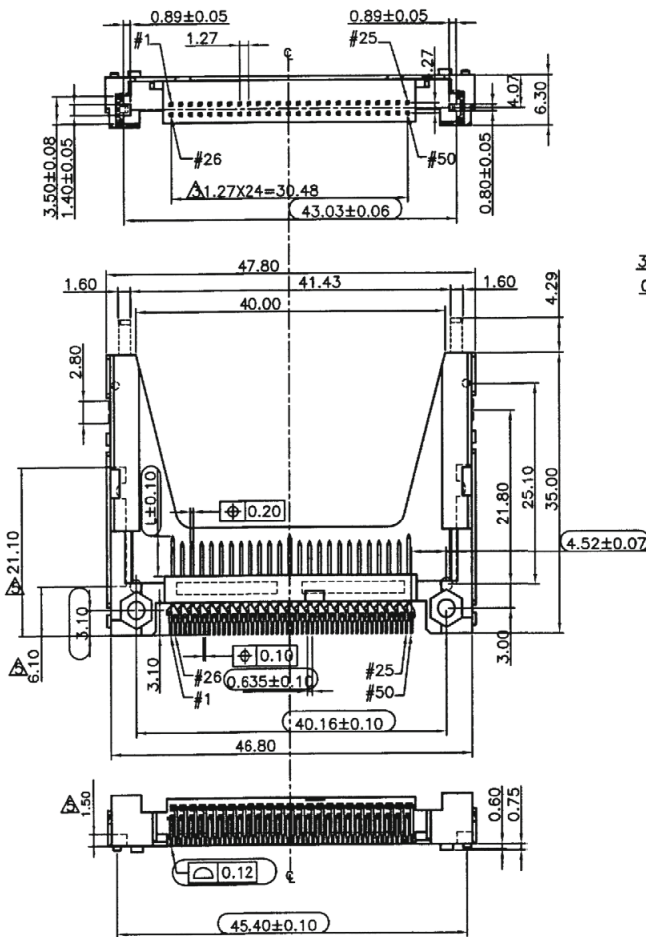

**PART NUMBER**

**CF 050 P2 - 0 1 3 - \* 0 DS 3**

Series	CF
No. of Contacts	050
Stand-off Height: 0 = without	P2 - 0
1 = Bottom Mounted on PCB	1
3 = 90° SMT	3
Ejector: 0 = Without 1 = Right Side	- * 0
Plating Area:	
Contacts: Gold (15μ") over 40μ" Nickel	
Solder Tails: 100μ" Tin over 40μ" Nickel	
No Mark = Without Foil	
3 = Mylar Foil	DS 3

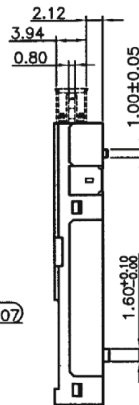
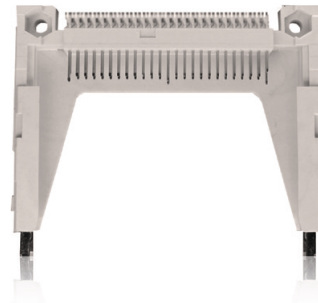

**RECOMMENDED PCB LAYOUT**

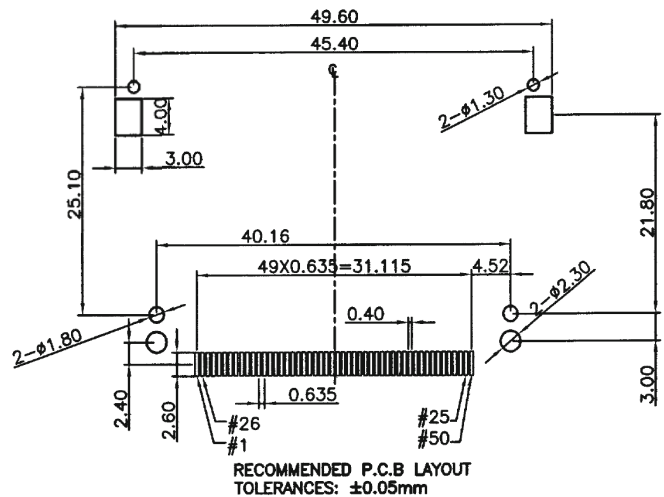

**SPECIFICATIONS**

Insulation Resistance:	1000MΩ at 500V DC
Withstanding Voltage:	500Vrms
Current Rating:	1A AC/DC max.
Contact Resistance:	40mΩ max. at 20mV max.
Operating Temp. Range:	-55°C to +85°C
Reflow Solder Temp.:	220°C min. / 60 sec., 260°C peak
Mating Cycles:	10,000 times

**MATERIALS AND FINISH**

Insulator:	LCP, glass filled (UL94V-0)
SMT Metal:	Brass, pure Sn
Contacts:	Brass
Plating:	Contacts - Gold (15μ") over Nickel (40μ") Solder Tails - pure Sn

**FEATURES**

- Adapter for Compact Flash Card type I and II
- Available for top and bottom PCB mounting
- Without cap for pick and place
- RoHS2011/65/EU

**OUTLINE DIMENSIONS**

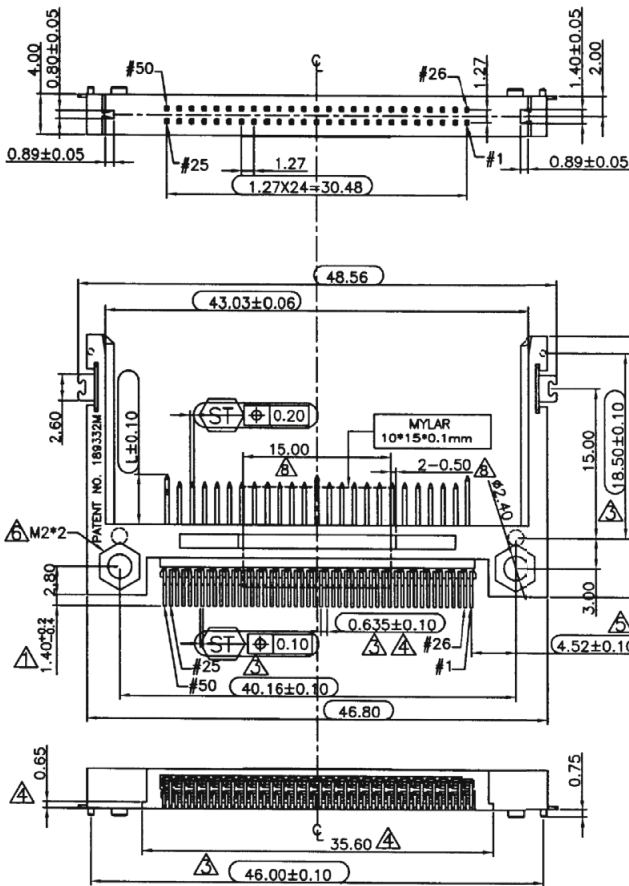

POWER	5.00mm	1,13,38,50
GENERAL	4.25mm	all other pins
DETECT	3.50mm	25,26
Pin type	Interface Dim. L	Pin No.

**PART NUMBER**

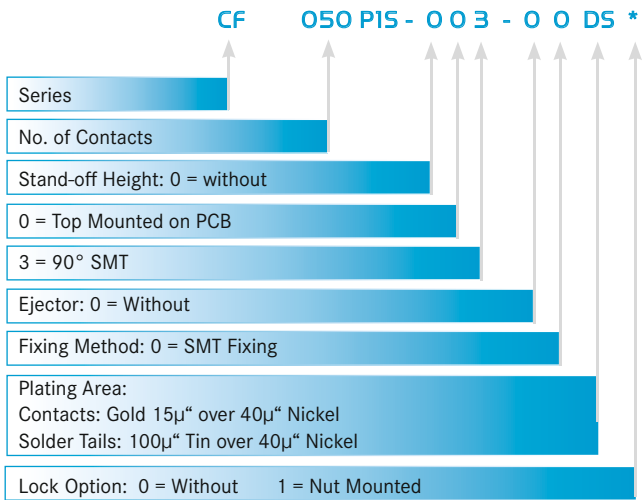

**RECOMMENDED PCB LAYOUT**

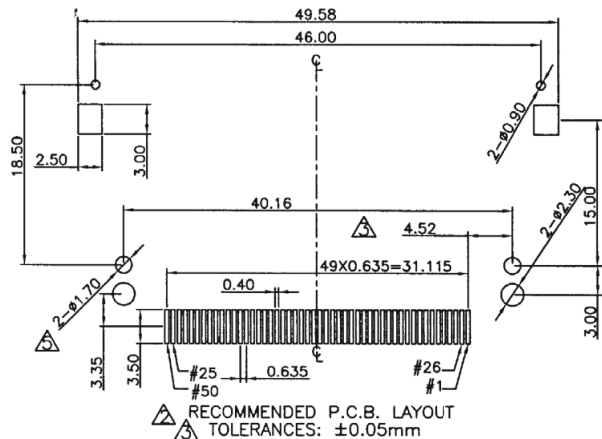

**SPECIFICATIONS**

Insulation Resistance:	1000MΩ at 500V DC
Withstanding Voltage:	500Vrms
Current Rating:	1A AC/DC max.
Contact Resistance:	40mΩ max. at 20mV max.
Operating Temp. Range:	-55°C to +85°C
Reflow Solder Temp.:	220°C min. / 60 sec., 260°C peak
Mating Cycles:	10,000 times

**MATERIALS AND FINISH**

Insulator:	LCP, glass filled (UL94V-0)
SMT Metal:	Brass, pure Sn
Contacts:	Brass
Plating:	Contacts - Gold (15μ") over Nickel (40μ") Solder Tails - pure Sn

**FEATURES**

- Adapter for Compact Flash Card Type I
- Available for top and bottom PCB mounting
- Without cap for pick and place
- RoHS2011/65/EU

**PART NUMBER**

**CF 050 P15 - 013 - 0 0 DS \***

Series	CF
No. of Contacts	050
Stand-off Height: 0 = without	P15
1 = Bottom Reversed on PCB	013
3 = 90° SMT	0
Ejector: 0 = Without	0
Fixing Method: 0 = SMT Fixing	DS
Plating Area:	
Contacts: Gold 15μ" over 40μ" Nickel	
Solder Tails: 100μ" Tin over 40μ" Nickel	
Lock Option: 0 = Without 1 = Nut Mounted	*



**OUTLINE DIMENSIONS**

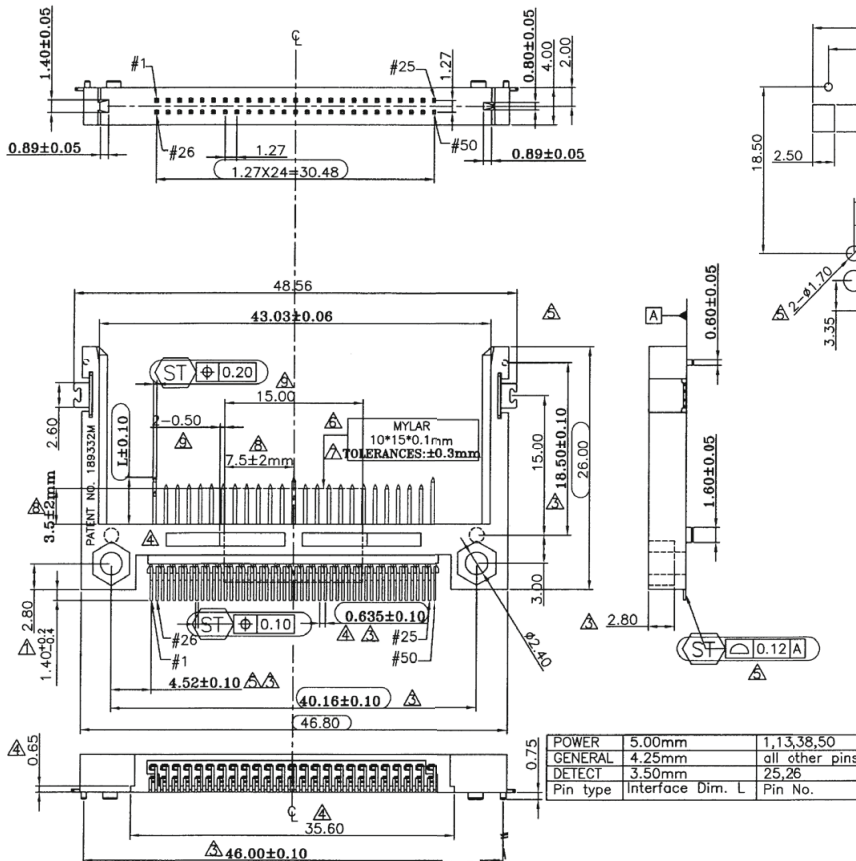

**RECOMMENDED PCB LAYOUT**

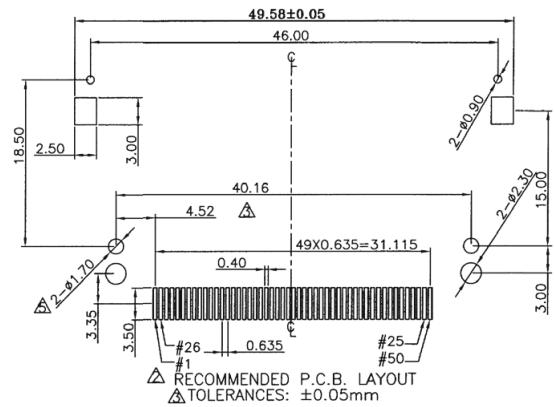

**SPECIFICATIONS**

Insulation Resistance: 1000MΩ at 500V DC  
 Withstanding Voltage: 500Vrms  
 Current Rating: 1A AC/DC max.  
 Contact Resistance: 40mΩ max. at 20mV max.  
 Operating Temp. Range: -55°C to +85°C  
 Reflow Solder Temp.: 220°C min. / 60 sec, 260°C peak  
 Mating Cycles: 10,000 times

**MATERIALS AND FINISH**

Insulator: LCP, glass filled (UL94V-0)  
 Push Button: Glass reinforced PBT (UL94V-0)  
 SMT Metal: Brass, pure Sn  
 Pivot Shell: Stainless Steel  
 Contacts: Brass  
 Plating: Contacts - Gold (15μ") over Nickel (40μ")  
 Solder Tails - pure Sn

**FEATURES**

- Adapter for Compact Flash Card type I and II
- Available with various ejectors and stand-offs
- RoHS2011/65/EU

**PART NUMBER**

**CF    050 P25 - \* 0 3 - \* 0 DS \***

Series	↑
No. of Contacts	↑
Stand-off Height 0 = Without    1 = 2.20mm	↑
PCB Mounting Type: 0 = Top	↑
90° SMT	↑
Ejector: 0 = Without 1 = Right Side (41.3mm) 2 = Left Side (41.3mm) 3 = Right Side (34.7mm) 4 = Left Side (34.7mm)	↑
Fixing Method: 0 = SMT Fixing	↑
Plating Area: Contacts: Gold 15μ" over 40μ" Nickel Solder Tails: 100μ" Tin over 40μ" Nickel	↑
Lock Option: 0 = Without    1 = Nut Mounted	↑

**OUTLINE DIMENSIONS (NO STAND-OFF)**

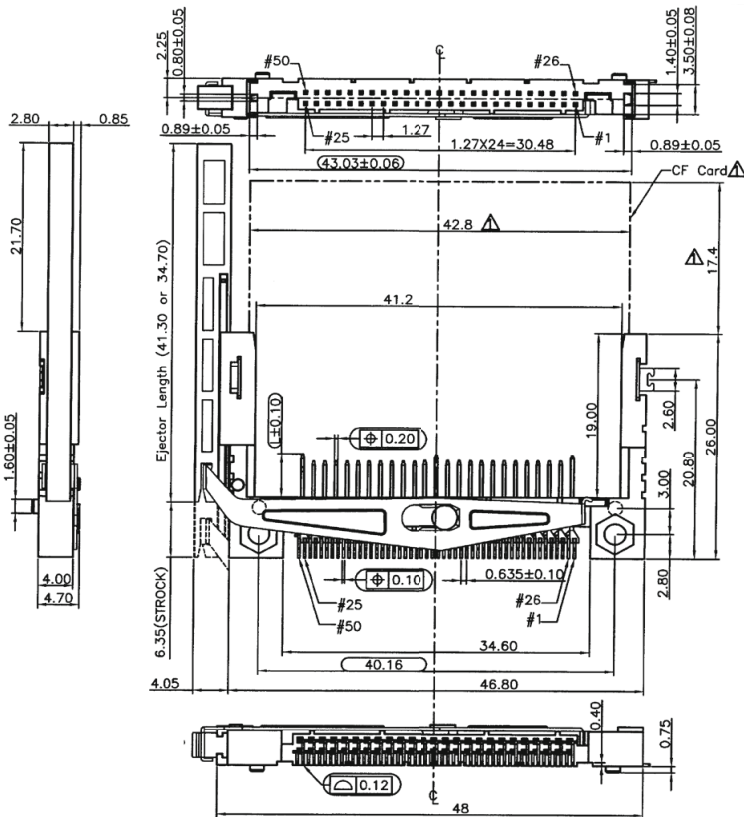

**RECOMMENDED PCB LAYOUT**

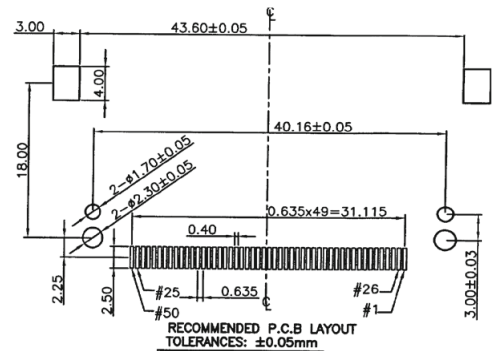

**SPECIFICATIONS**

Insulation Resistance: 1000MΩ at 500V DC  
 Withstanding Voltage: 500Vrms  
 Current Rating: 1A AC/DC max.  
 Contact Resistance: 40mΩ max. at 20mV max.

Operating Temp. Range: -55°C to +85°C  
 Reflow Solder Temp.: 220°C min. / 60 sec, 260°C peak  
 Mating Cycles: 10,000 times

**MATERIALS AND FINISH**

Insulator: LCP, glass filled (UL94V-0)  
 Push Button: Glass reinforced PBT (UL94V-0)  
 SMT Metal: Brass, pure Sn  
 Pivot Shell: Stainless Steel  
 Contacts: Brass  
 Plating: Contacts - Gold (15μ") over Nickel (40μ")  
 Solder Tails - pure Sn

**FEATURES**

- Reverse type without stand-off height is not applicable to Compact Flash Card Type II
- Adapter for Compact Flash Card type I and II
- Available with various ejectors
- RoHS2011/65/EU

**PART NUMBER**

**CF    050 P25 - \* 13 - \* 0 D5 \***

Series	CF
No. of Contacts	050
Stand-off Height 0 = Without    1 = 2.20mm	P25
PCB Mounting Type: 1 = Bottom Reverse	- * 13 - *
90° SMT	0 D5 *
Ejector: 0 = Without 1 = Right Side (41.3mm) 2 = Left Side (41.3mm) 3 = Right Side (34.7mm) 4 = Left Side (34.7mm)	
Fixing Method: 0 = SMT Fixing	
Plating Area: Contacts: Gold 15μ" over 40μ" Nickel Solder Tails: 100μ" Tin over 40μ" Nickel	
Lock Option: 0 = Without    1 = Nut Mounted	

**OUTLINE DIMENSIONS (STAND-OFF HEIGHT 2.20MM)**

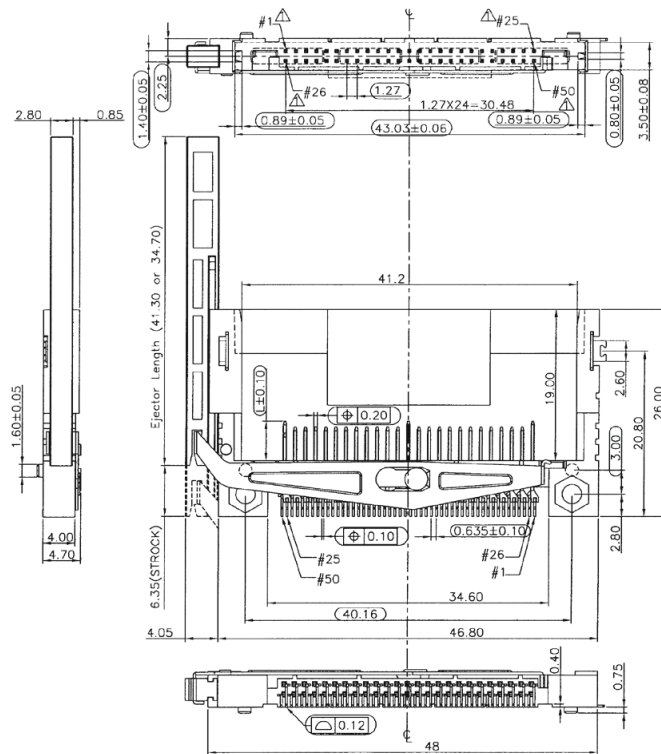

**RECOMMENDED PCB LAYOUT**

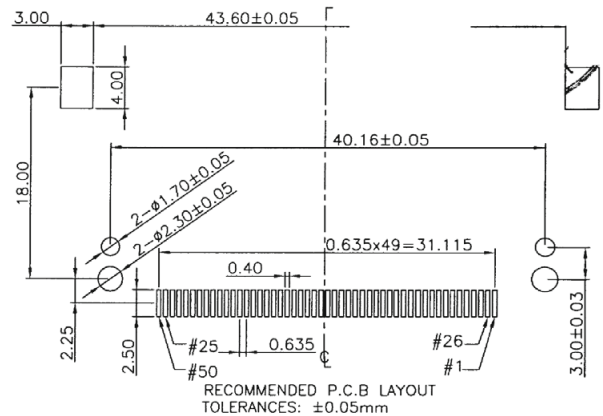

**FEATURES**

- Locking bow secure the Compact Flash card in the connector
- Locking bow must be used in combination with CF050P2-\*03-00-DS connectors
- Locking bow is attached after the CF card is inserted into the connector
- RoHS2011/65/EU

**PART NUMBER**

**CF 050P2-LT REV3.0**

Series	↑
Design No.	↑



**OUTLINE DIMENSIONS**

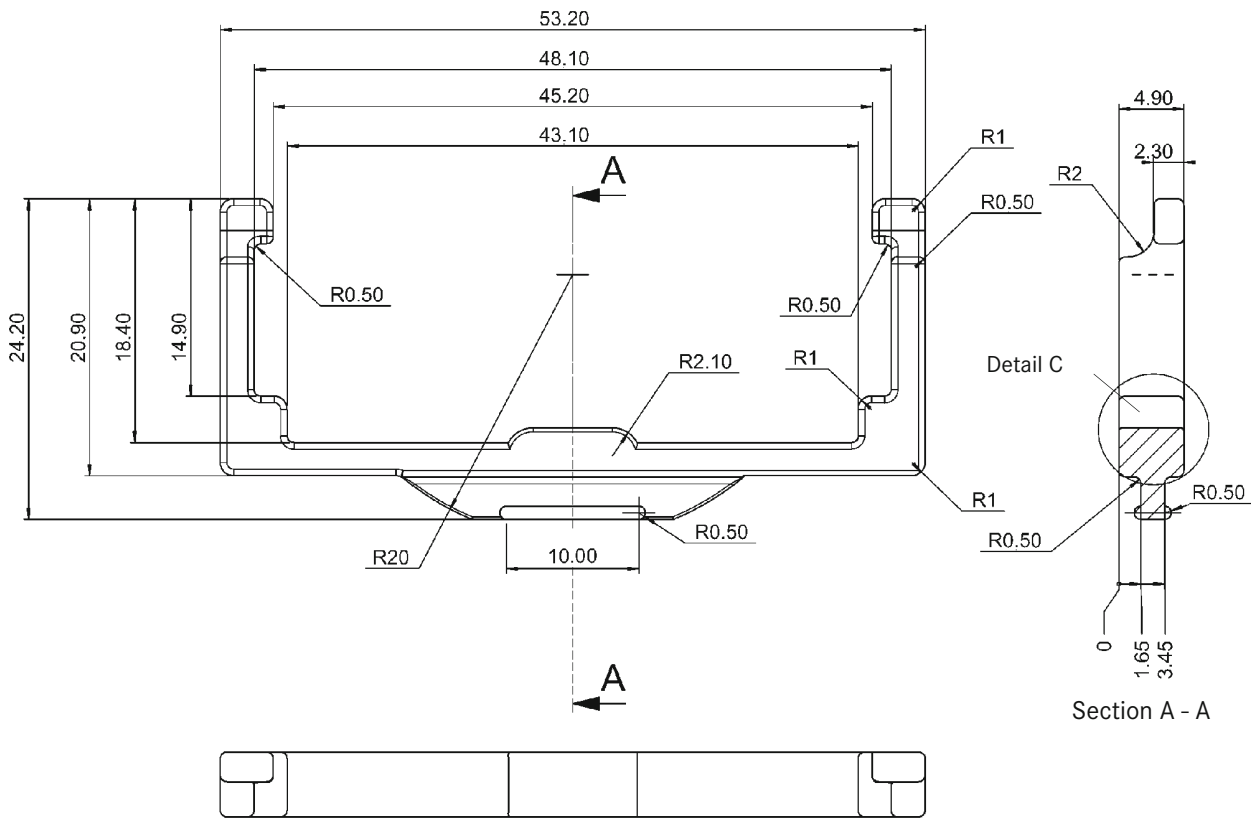

**DETAIL C**

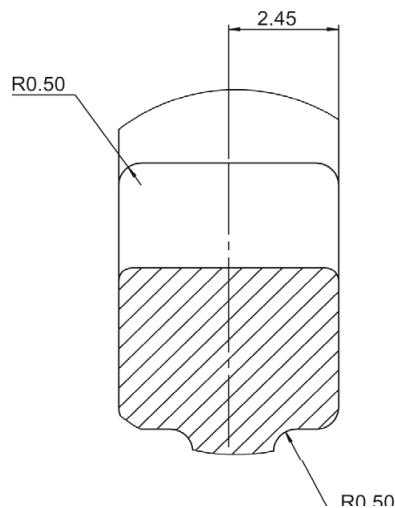

### AUSTRIA / EASTERN EUROPE

CODICO GmbH & Co. KG  
Zwingenstrasse 6 - 8  
2380 Perchtoldsdorf  
Austria

Contact: Mr. Christian Sichtar

Tel.: +43 186 305 0  
Fax: +43 186 305 5000  
e-mail: office@codico.com  
Internet: www.codico.com

### FINLAND

Yleiselektroniikka OY  
Po Box 73  
Luomannotko 6  
02201 Espoo  
Finland

Contact: Mr. Kai Nurmenniemi

Tel.: +358 10 2891 200  
Fax: +358 10 2891 270  
e-mail: kai.nurmenniemi@yeint.fi  
Internet: www.yeint.fi

### ISRAEL

Teder Electro Mechanical Engineering  
14 Atir Yeda st.  
Kfar-Saba 4464323  
Israel

Contact: Mr. Gadi Feit

Tel.: +972 73 2331200  
Fax: +972 73 2331233  
e-mail: sales@teder.com  
Internet: www.teder.com

### PORTUGAL

Sagitrón S.A.  
Lisbon  
Portugal

Tel.: +351 218 288614  
Fax: +351 218 288614  
e-mail: portugal@sagitron.com  
Internet: www.sagitron.com

### UNITED KINGDOM

Cyntech Components Ltd.  
Unit 29, Chancerygate Business Park  
Goulds Close, Denbigh West,  
Milton Keynes MK1 1EQ  
UK

Contact: Mr. Ian Mort

Tel.: +44 (0)1908 37 39 27  
Fax: +44 (0)1908 36 53 05  
e-mail: sales@cyntech.co.uk  
Internet: www.cyntech.co.uk

### BENELUX

Logic Technology B.V.  
John F. Kennedylaan 18  
5981 XC Panningen  
The Netherlands

Contact: Mr. René Janssen or  
Mr. André de Ceuninck

Tel.: +31 77 307 8438  
Fax: +31 77 307 8439  
e-mail: info@logic.nl  
Internet: www.logic.nl/yamaichi

### FRANCE

Manudax - France  
ZA les Petites Haies  
28, rue de Valenton  
BP302  
94709 Maisons-Alfort Cedex  
France

Contact: Mr. Philippe Matoulet or  
Mr. Christophe Lazerges

Tel.: +33 1 41 789444  
Fax: +33 1 48 994186  
e-mail: manudax@manudax.fr  
Internet: www.manudax.fr

### RUSSIA

YE International  
Obukhovskoy Oborony, 70, bld. 3A  
St. Petersburg, 192029  
Russia

Contact: Mr. Alexander Muraviev

Tel. +7 812 313 34 40 ext.613  
Fax. +7 812 313 34 41  
e-Mail: alexander.muraviev@yeint.ru  
Internet: www.yeint.ru

### SWEDEN

Nanomil AB  
Vendevägen 90  
SE-182 32 Danderyd  
Sweden

Contact: Mr. Christian Rassmussen

Tel. +46 8 684 051 42  
Fax. +46 739 013 742  
e-Mail: christian@nanomil.se  
Internet: www.nanomil.se

### DENMARK

Cabcon A/S  
Stamholmen 193 A  
2650 Hvidovre,  
Denmark

Contact: Mr. Brian Dehlisen or  
Mr. Flemming Schandorph

Tel. +45 38 76 03 15  
Fax. +45 38 76 03 20  
e-mail: fs@cabcon.dk  
internet: www.cabcon.dk

### GERMANY

GLYN GmbH & Co. KG  
Am Wörtzgarten 8  
65510 Idstein / Taunus  
Germany

Contact: Mr. Heiko Keller

Tel.: +49 (0)6126 590342  
Fax: +49 (0)6126 590132  
e-mail: heiko.keller@glyn.de  
Internet: www.glyn.de

### SWITZERLAND

Sicovend AG  
Alte Poststrasse 1  
8310 Kempthal  
Switzerland

Contact: Mr. Othmar Stocker

Tel.: +41 52 354 80 24  
Fax: +41 52 354 80 00  
e-mail: othmar.stocker@sicovend.ch  
Internet: www.sicovend.ch





The technical data and specifications of the products shown in this catalogue are for reference only, and apply to products available at the time of catalogue printing in Sept. 2016. Product modification often involves changes to technical data and size, and it is therefore recommended that the buyer request the latest technical data and specifications before placing a purchasing contract.

Future updates to this printed catalogue can be found at  
<https://www.yamaichi.de/downloads/product-catalogues.html>

Technische Daten und Maßangaben der im Katalog aufgeführten Produkte beziehen sich auf Referenzprodukte aus dem Produktsortiment bei Erscheinen des Katalogs im Sept. 2016. Produktänderungen, insbesondere aufgrund technischer Weiterentwicklung, bedingen regelmäßig veränderte technische Daten und Maße. Dem Besteller wird daher dringend empfohlen, vor Vertragsabschluss technische Daten und Maßangaben gesondert nachzufragen.

Zukünftige Updates dieses gedruckten Katalogs finden Sie auf  
<https://www.yamaichi.de/de/downloads/produktkataloge.html>



## CARD CONNECTORS

Version November 2018

TECHNICAL DATA ARE SUBJECT TO ALTERATION WITHOUT PRIOR NOTICE

### **YAMAICHI ELECTRONICS**

Deutschland GmbH  
Concor Park  
Bahnhofstraße 20  
85609 Aschheim-Dornach  
Germany

**Phone** +49 (0)89 45109-0  
**Fax** +49 (0)89 45109-110  
**E-Mail** [sales@yamaichi.de](mailto:sales@yamaichi.de)  
**Web** [www.yamaichi.de](http://www.yamaichi.de)

### **YAMAICHI ELECTRONICS**

Italia s.r.l.  
Centro Direzionale Colleoni  
Via Colleoni, 1  
Palazzo Taurus Ing. 1  
20864 Agrate Brianza (MB)  
Italy

**Phone** +39 039 6881-185  
**Fax** +39 039 6892-150  
**E-Mail** [sales@yamaichi.it](mailto:sales@yamaichi.it)  
**Web** [www.yamaichi.it](http://www.yamaichi.it)

### **YAMAICHI ELECTRONICS**

GB Ltd.  
6 The Clockhouse  
Stratton Park  
Micheldever  
Hampshire SO21 3DP  
Great Britain

**Phone** +44 (0)7808 493377  
**Fax** +44 (0)1962 774902  
**E-Mail** [sales@yamaichi.co.uk](mailto:sales@yamaichi.co.uk)  
**Web** [www.yamaichi.co.uk](http://www.yamaichi.co.uk)