

(4X) EACH #10-32 BRASS INSERTS, AND 316 STAINLESS STEEL CAPTIVE COVER SCREWS WITH RETAINING O-RING

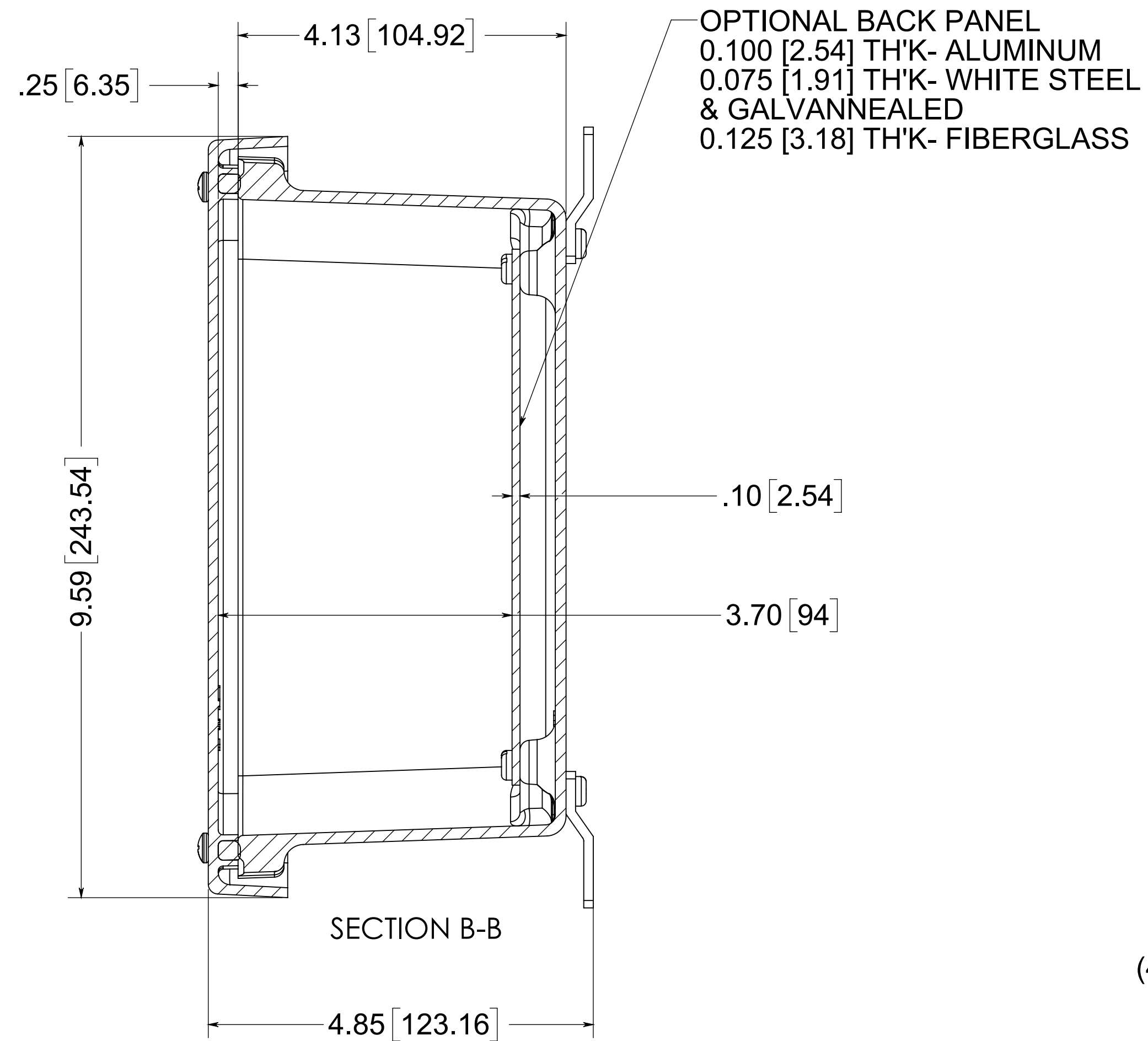

OPTIONAL BACK PANEL  
0.100 [2.54] TH'K- ALUMINUM  
0.075 [1.91] TH'K- WHITE STEEL & GALVANNEALED  
0.125 [3.18] TH'K- FIBERGLASS

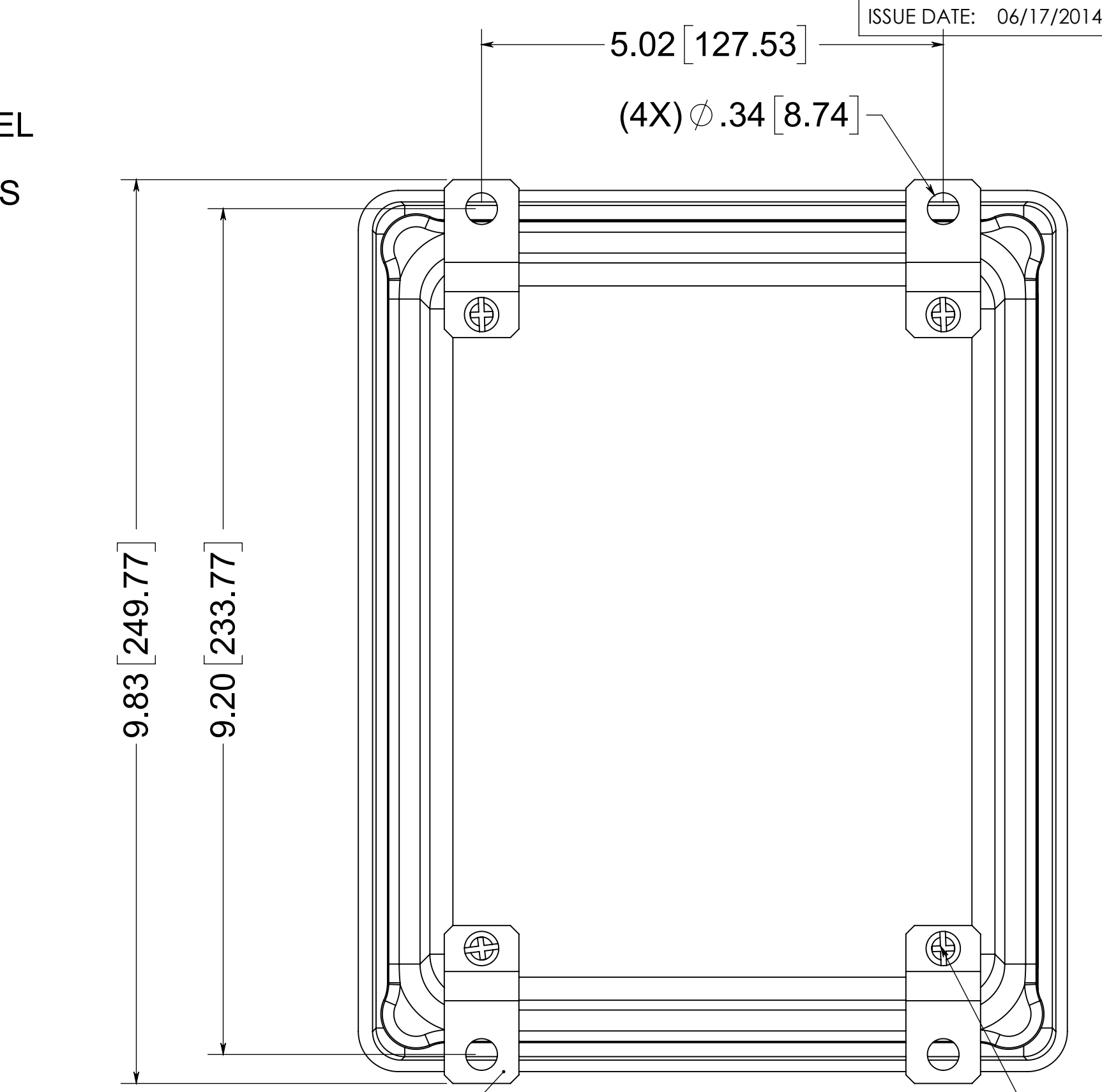

(4X) 316 STAINLESS STEEL FEET

(4X) EACH #10-32 BRASS INSERTS, AND 316 STAINLESS STEEL FEET SCREWS

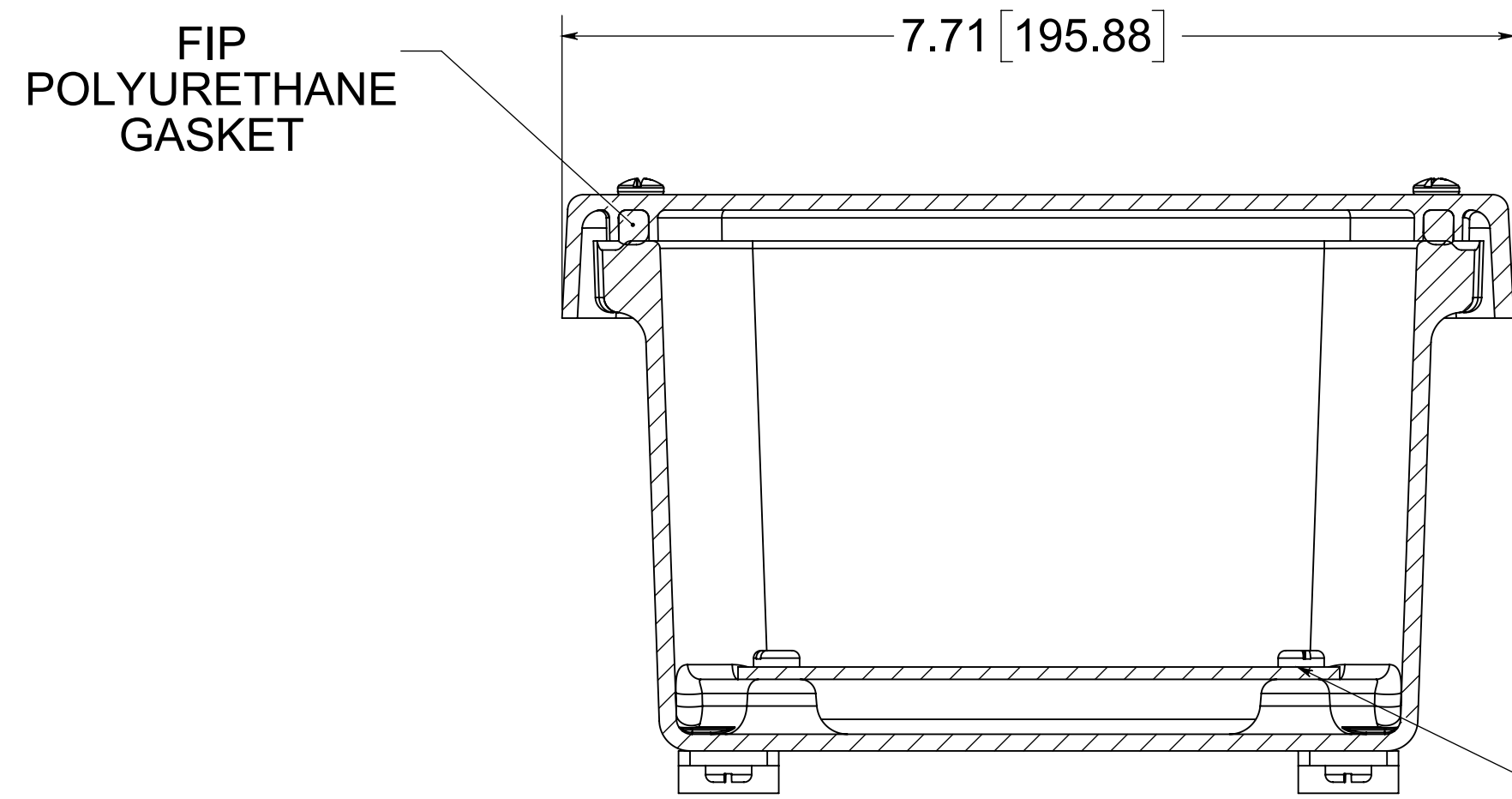

SECTION A-A

(4X) EACH #10-32 BRASS INSERTS AND PLATED CARBON STEEL SCREWS

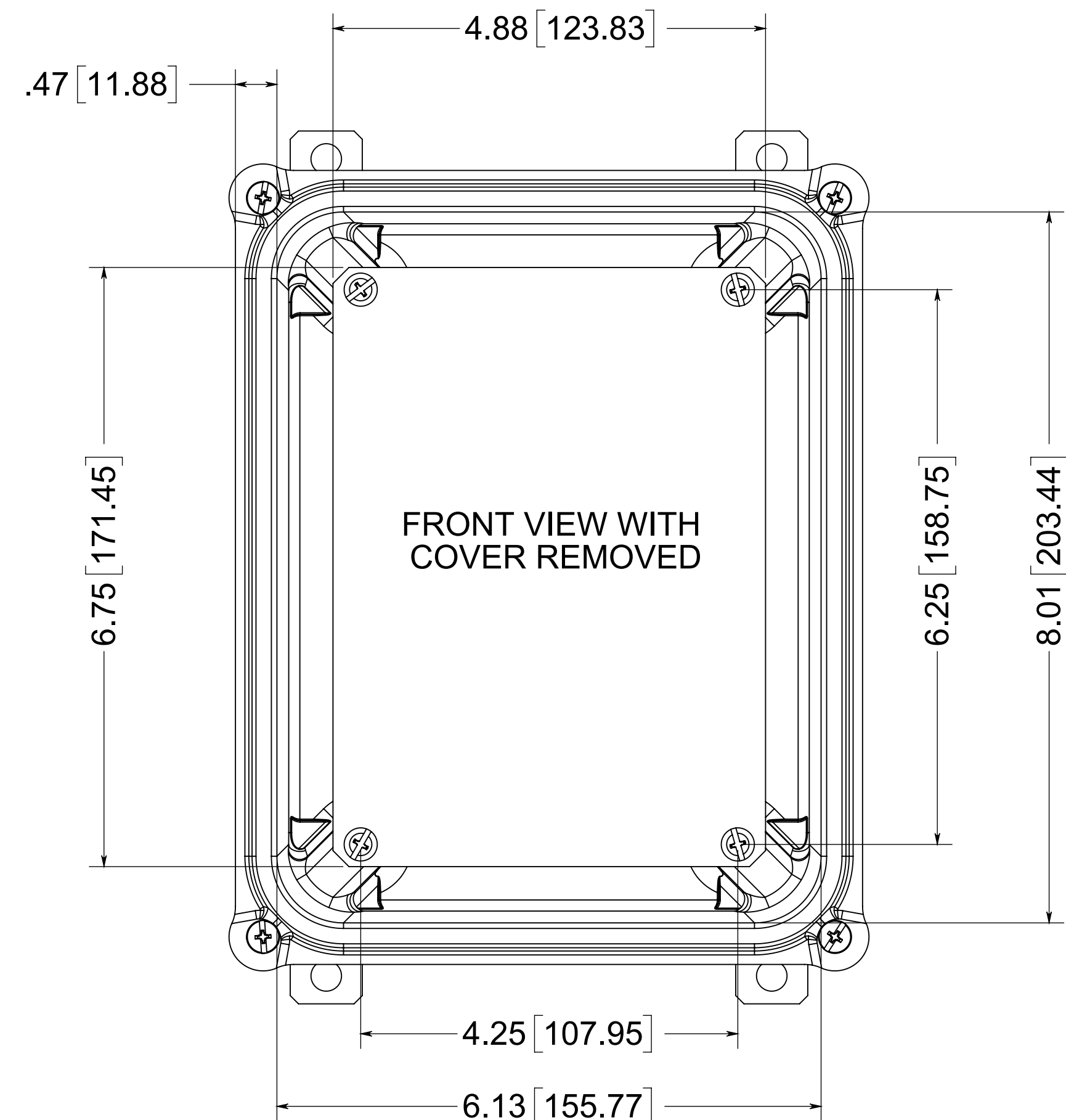

MATERIAL:  
BOX- COMPRESSION MOLDED FIBERGLASS REINFORCED POLYESTER  
COVER- COMPRESSION MOLDED FIBERGLASS REINFORCED POLYESTER  
WINDOW- POLYCARBONATE

NOTE:  
1. DATA SUBJECT TO CHANGE WITHOUT NOTICE

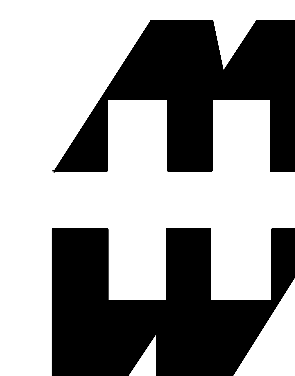

PART No. PJ864

for more information visit  
[www.hammfg.com](http://www.hammfg.com)

Data subject to change without notice

Drawing Not to Scale