

11 – 36V_{IN}, 5V_{OUT}, 15A ZVS Buck Regulator

Product Description

The PI3302-03 is a high-efficiency, wide-input-range DC-DC ZVS Buck Regulator integrating controller, power switches and support components all within a high-density System-in-Package (SiP). The integration of a high-performance Zero-Voltage Switching (ZVS) topology, within the PI3302-03 model, increases point-of-load performance providing best-in-class power efficiency. The PI3302-03 requires only an external inductor and minimal capacitors to form a complete DC-DC switching-mode Buck Regulator.

Device	Output Voltage		I _{OUT} Max
	Set	Range	
PI3302-03-LGIZ	5.0V	3.3 – 6.5V	15A

The ZVS architecture also enables high-frequency operation while minimizing switching losses and maximizing efficiency. The high switching frequency operation reduces the size of the external filtering components, improves power density and enables very fast dynamic response to line and load transients.



Features & Benefits

- High-Efficiency ZVS Buck Topology
- Wide input voltage range of 11 – 36V
- Output power up to 75W
- Very fast transient response
- High-accuracy pre-trimmed output voltage
- User-adjustable soft start & tracking
- Parallel capable with single-wire current sharing
- Input Over/Undervoltage Lockout (OVLO/UVLO)
- Output Overvoltage Protection (OVP)
- Overtemperature Protection (OTP)
- Fast and slow current limits
- –40 to 125°C operating range (T_J)

Applications

- High-efficiency systems
- Computing, Communications, Industrial, Automotive Equipment
- High-voltage battery operation

Package Information

- 10 x 14 x 2.6mm (LGA SiP)

Contents

Order Information	3	Application Description	11
Thermal, Storage and Handling Information	3	Output Voltage Trim	11
Absolute Maximum Ratings	3	Soft Start Adjust and Tracking	12
Functional Block Diagram	4	Inductor Pairing	12
Pin Description	5	Thermal De-rating	13
Package Pinout	5	I²C™ Operation	13
Electrical Characteristics	6	Filter Considerations	13
Functional Description	10	Layout Guidelines	14
ENABLE (EN)	10	Recommended PCB Footprint and Stencil	15
Remote Sensing	10	Package Drawings	16
Switching Frequency Synchronization	10	Revision History	17
Soft Start	10	Product Warranty	18
Output Voltage Trim	10		
Output Current Limit Protection	10		
Input Undervoltage Lockout	10		
Input Overvoltage Lockout	10		
Output Overvoltage Protection	11		
Overtemperature Protection	11		
Pulse Skip Mode (PSM)	11		
Variable Frequency Operation	11		
Parallel Operation	11		

Order Information

Part Number	Output Range		I _{OUT} Max	Operating Range (T _{INT})	Package	Transport Media
	Set	Range				
PI3302-03-LGIZ	5.0V	3.3 – 6.5V	15A	–40 to 125°C	10 x 14mm 123-pin LGA	TRAY

Thermal, Storage and Handling Information

Name	Rating
Storage Temperature	–65 to 150°C
Internal Operating Temperature	–40 to 125°C
Soldering Temperature for 20 seconds	245°C
MSL Rating	3
ESD Rating	2kV HBM

Absolute Maximum Ratings

Name	Rating
VIN	–0.7 to 36V
VS1	–0.7 to 36V, –4V for 5ns
SGND	100mA
PGD, SYNCO, SYNCL, EN, EAO, ADJ, TRK, ADR1, ADR2, SCL, SDA, REM	–0.3 to 5.5V / 5mA
VOUT	–1.5 to 21V

Notes: At 25°C ambient temperature. Stresses beyond these limits may cause permanent damage to the device. Operation at these conditions or conditions beyond those listed in the Electrical Specifications table is not guaranteed. All voltage nodes are referenced to PGND unless otherwise noted. Test conditions are per the specifications within the individual product electrical characteristics.

Pin Description

Name	Location	I/O	Description
SGND	Block 1	I/O	Signal ground: Internal logic ground for EA, TRK, SYNCI, SYNCO, ADJ and I ² C™ (options) communication returns. SGND and PGND are star connected within the regulator package.
PGND	Block 2	Power	Power ground: VIN and VOUT power returns.
VIN	Block 3	Power	Input voltage: and sense for UVLO, OVLO and feed forward ramp.
VOUT	Block 5	Power	Output voltage: and sense for power switches and feed-forward ramp.
VS1	Block 4	Power	Switching node: and ZVS sense for power switches.
PGD	A1	O	Power Good: High impedance when regulator is operating and V _{OUT} is in regulation. May also be used as “Parallel Good” – see applications section.
EAO	A2	O	Error amp output: External connection for additional compensation and current sharing.
EN	A3	I/O	Enable Input: Regulator enable control. Asserted high or left floating – regulator enabled; Asserted low, regulator output disabled. Polarity is programmable via I ² C interface.
REM	A5	I	Remote Sense: High side connection. Connect to output regulation point.
ADJ	B1	I	Adjust input: An external resistor may be connected between ADJ pin and SGND or VOUT to trim the output voltage up or down.
TRK	C1	I/O	Soft start and track input: An external capacitor may be connected between TRK pin and SGND to decrease the rate of rise during soft start.
NC	A4, K3	Open	No Connect: Leave pins floating.
SYNCO	K4	O	Synchronization output: Outputs a low signal for ½ of the minimum period for synchronization of other converters.
SYNCI	K5	I	Synchronization input: Synchronize to the falling edge of external clock frequency. SYNCI is a high impedance digital input node and should always be connected to SGND when not in use.
SDA	D1	I/O	Data Line: I ² C serial data line.
SCL	E1	I/O	Clock Line: I ² C serial clock line.
ADR1	H1	I	Tri-state Address: Supports I ² C addressing.
ADR0	G1	I	Tri-state Address: Supports I ² C addressing.

Package Pinout

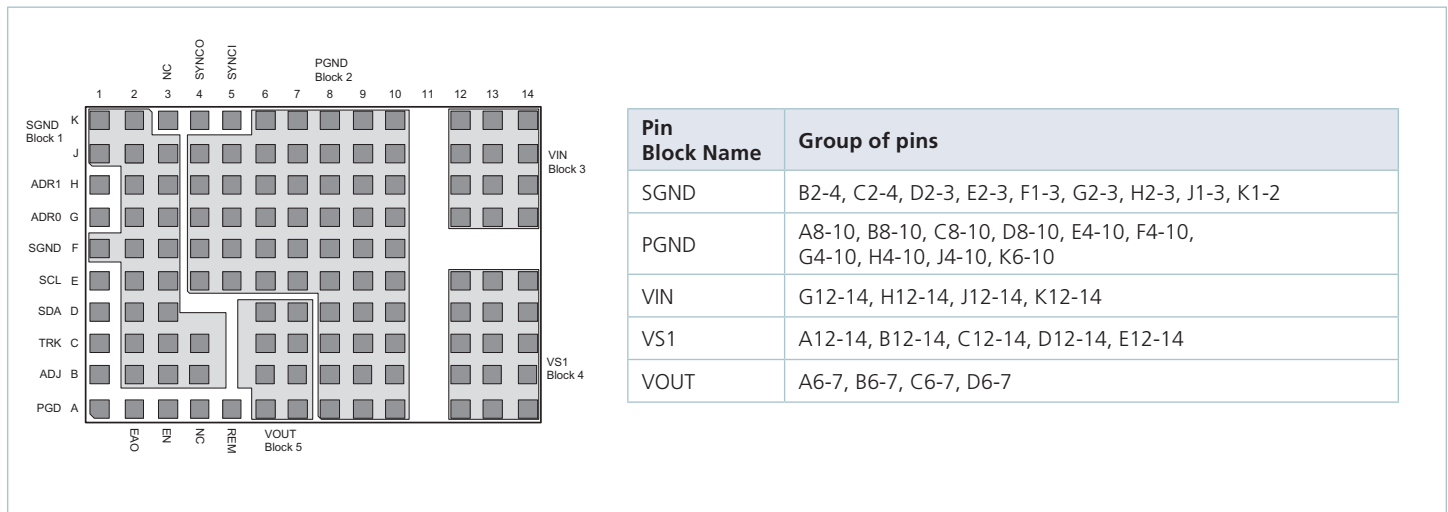

Electrical Characteristics

Specifications apply for the conditions $-40^{\circ}\text{C} < T_{\text{INT}} < 125^{\circ}\text{C}$, $V_{\text{IN}} = 24\text{V}$, $L1 = 185\text{nH}$ ^[a] unless other conditions are noted.

Parameter	Symbol	Conditions	Min	Typ	Max	Unit
Input Specifications						
Input Voltage	$V_{\text{IN_DC}}$	^[g]	11	24	36	V
Input Current	$I_{\text{IN_DC}}$	$V_{\text{IN}} = 24\text{V}$, $T_{\text{C}} = 25^{\circ}\text{C}$, $I_{\text{OUT}} = 15\text{A}$		3.31		A
Input Current At Output Short (fault condition duty cycle)	$I_{\text{IN_Short}}$	^[b]			20	mA
Input Quiescent Current	$I_{\text{Q_VIN}}$	Disabled		2.0		mA
		Enabled (no load)		2.5		
Input Voltage Slew Rate	$V_{\text{IN_SR}}$	^[b]			1	V/ μs
Output Specifications						
Output Voltage Total Regulation	$V_{\text{OUT_DC}}$	^[b]	4.92	5.00	5.08	V
Output Voltage Trim Range		^{[c][g]}	3.3		6.5	V
Line Regulation	$\Delta V_{\text{OUT}} (\Delta V_{\text{IN}})$	@ 25°C , $11\text{V} < V_{\text{IN}} < 36\text{V}$		0.10		%
Load Regulation	$\Delta V_{\text{OUT}} (\Delta I_{\text{OUT}})$	@ 25°C , $0.5\text{A} < I_{\text{OUT}} < 15\text{A}$		0.10		%
Output Voltage Ripple	$V_{\text{OUT_AC}}$	$I_{\text{OUT}} = 7.5\text{A}$, $C_{\text{OUT}} = 5 \times 47\mu\text{F}$ 20MHz BW ^[d]		44		mV _{P-P}
Continuous Output Current Range	$I_{\text{OUT_DC}}$	^{[e] [g]}			15	A
Current Limit	$I_{\text{OUT_CL}}$			18		A
Protection						
V_{IN} UVLO Start Threshold	$V_{\text{UVLO_START}}$		9.6	10.4	10.87	V
V_{IN} UVLO Stop Threshold	$V_{\text{UVLO_STOP}}$		9.3	9.9	10.6	V
V_{IN} UVLO Hysteresis	$V_{\text{UVLO_HYS}}$			0.50		V
V_{IN} OVLO Start Threshold	$V_{\text{OVLO_START}}$		36.1	37.6		V
V_{IN} OVLO Stop Threshold	$V_{\text{OVLO_STOP}}$		37.0	38.4		V
V_{IN} OVLO Hysteresis	$V_{\text{OVLO_HYS}}$			0.8		V
V_{IN} UVLO/OVLO Response Time	t_{r}			500		ns
Output Overvoltage Protection	V_{OVP}	Above V_{OUT}		20		%
Overtemperature Fault Threshold	T_{OTP}	^[b]	130	135	140	$^{\circ}\text{C}$
Overtemperature Restart Hysteresis	$T_{\text{OTP_HYS}}$			30		$^{\circ}\text{C}$
Timing						
Switching Frequency	f_{s}	^[f]		0.800		MHz
Fault Restart Delay	$t_{\text{FR_DLY}}$			36		ms
Sync In (SYNCI)						
Synchronization Frequency Range	Δf_{SYNCI}	Relative to set switching frequency ^[c]	50		110	%
SYNCI Threshold	V_{SYNCI}			2.5		V

^[a] All parameters reflect regulator and inductor system performance. Measurements were made using a standard PI3302-03 evaluation board with 3x4" dimensions and 4 layer, 2oz copper. Refer to inductor pairing table within Application Description section for specific inductor manufacturer and value.

^[b] Regulator is assured to meet performance specifications by design, test correlation, characterization, and/or statistical process control.

^[c] Output current capability may be limited and other performance may vary from electrical characteristics when switching frequency or V_{OUT} is modified.

^[d] Refer to Output Ripple plots.

^[e] Refer to Load Current vs. Ambient Temperature curves.

^[f] Refer to Switching Frequency vs. Load current curves.

^[g] $V_{\text{IN}} - V_{\text{OUT}}$ must be 5V or more to avoid a minimum load requirement of 3mA. Regulator must be disabled if $V_{\text{IN}} - V_{\text{OUT}}$ is less than 1V.

Electrical Characteristics (Cont.)

Specifications apply for the conditions $-40^{\circ}\text{C} < T_{\text{INT}} < 125^{\circ}\text{C}$, $V_{\text{IN}} = 24\text{V}$, $L1 = 185\text{nH}$ ^[a] unless other conditions are noted.

Parameter	Symbol	Conditions	Min	Typ	Max	Unit
Sync Out (SYNCO)						
SYNCO High	$V_{\text{SYNCO_HI}}$	Source 1mA	4.5			V
SYNCO Low	$V_{\text{SYNCO_LO}}$	Sink 1mA			0.5	V
SYNCO Rise Time	$t_{\text{SYNCO_RT}}$	20pF load		10		ns
SYNCO Fall Time	$t_{\text{SYNCO_FT}}$	20pF load		10		ns
Soft Start and Tracking						
TRK Active Input Range	V_{TRK}		0		1.04	V
TRK Max Output Voltage				1.2		V
TRK Disable Threshold	$V_{\text{TRK_OV}}$		20	40	60	mV
Charge Current (Soft Start)	I_{TRK}		-70	-50	-30	μA
Discharge Current (Fault)	$I_{\text{TRK_DIS}}$			6.8		mA
Soft-Start Time	t_{SS}	$C_{\text{TRK}} = 0\mu\text{F}$		2.2		ms
Enable						
High Threshold	$V_{\text{EN_HI}}$		0.9	1	1.1	V
Low Threshold	$V_{\text{EN_LO}}$		0.7	0.8	0.9	V
Threshold Hysteresis	$V_{\text{EN_HYS}}$		100	200	300	mV
Enable Pull-Up Voltage (floating, unfaulted)	$V_{\text{EN_PU}}$			2		V
Enable Pull-Down Voltage (floating, faulted)	$V_{\text{EN_PD}}$			0		V
Source Current	$I_{\text{EN_SO}}$			-50		μA
Sink Current	$I_{\text{EN_SK}}$			50		μA
PGD						
PGD Rising Threshold	$V_{\text{PG_HI\%}}$	[b]	79	85	91	% $V_{\text{OUT_DC}}$
PGD Falling Threshold	$V_{\text{PG_LO\%}}$	[b]	77	83	89	% $V_{\text{OUT_DC}}$
PGD Output Low	$V_{\text{PG_SAT}}$	Sink = 4mA [b]			0.4	V
PGD Sink Current	$I_{\text{PG_SAT}}$	[b]		4		mA

^[a] All parameters reflect regulator and inductor system performance. Measurements were made using a standard PI3302-03 evaluation board with 3x4" dimensions and 4 layer, 2oz copper. Refer to inductor pairing table within Application Description section for specific inductor manufacturer and value.

^[b] Regulator is assured to meet performance specifications by design, test correlation, characterization, and/or statistical process control.

^[c] Output current capability may be limited and other performance may vary from electrical characteristics when switching frequency or V_{OUT} is modified.

^[d] Refer to Output Ripple plots.

^[e] Refer to Load Current vs. Ambient Temperature curves.

^[f] Refer to Switching Frequency vs. Load current curves.

^[g] $V_{\text{IN}} - V_{\text{OUT}}$ must be 5V or more to avoid a minimum load requirement of 3mA. Regulator must be disabled if $V_{\text{IN}} - V_{\text{OUT}}$ is less than 1V.

PI3302-03 (5.0V_{OUT}) Electrical Characteristics

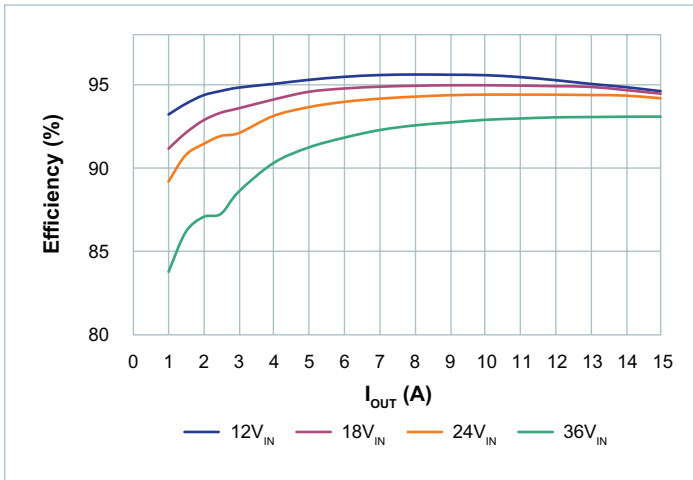

Figure 1 — Efficiency at 25°C

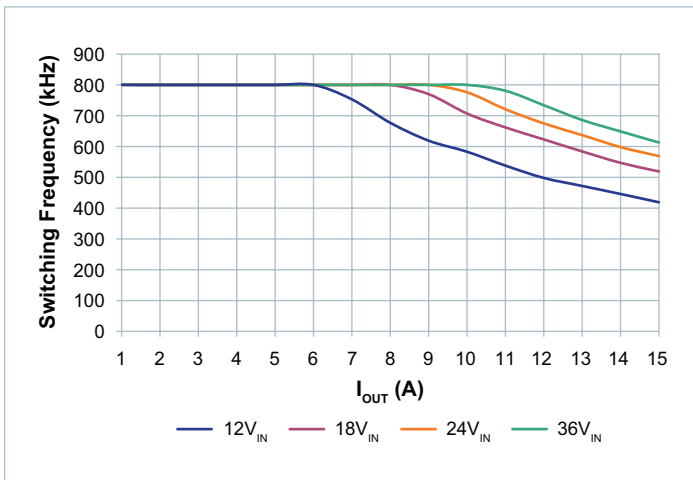

Figure 2 — Switching frequency vs. load current

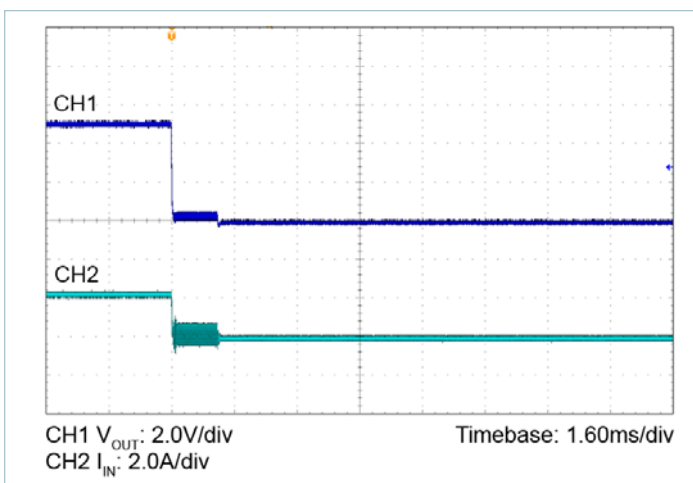

Figure 3 — Short circuit test

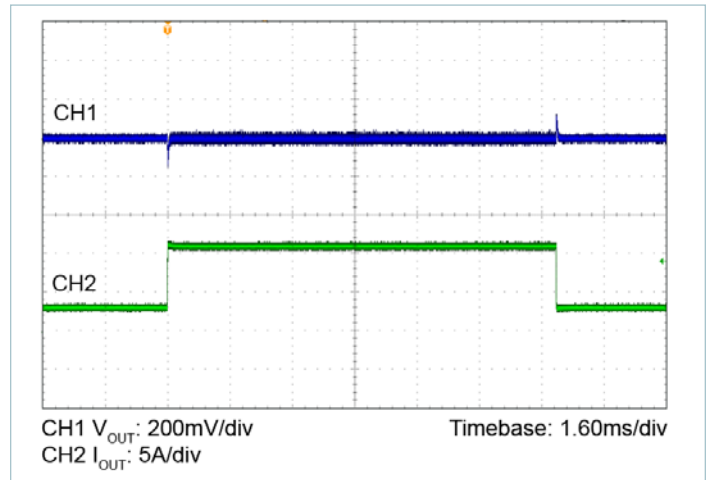

Figure 4 — Transient response: 3.75 – 11.25A, at 5A/μs

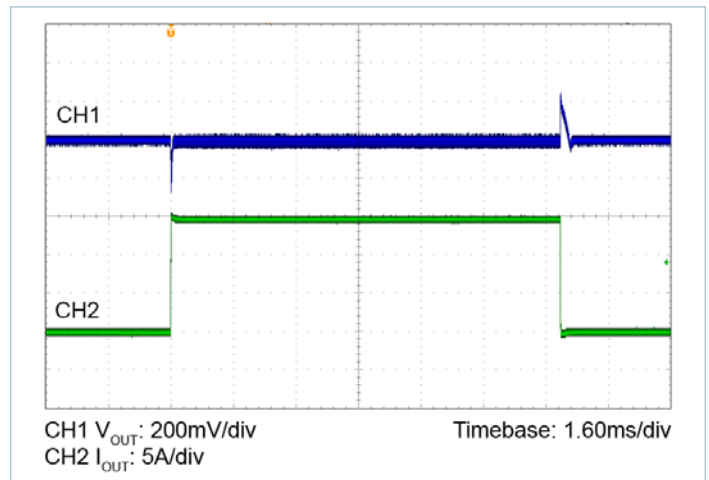

Figure 5 — Transient response: 0 – 15A, at 5A/μs

PI3302-03 (5.0V_{OUT}) Electrical Characteristics (Cont.)

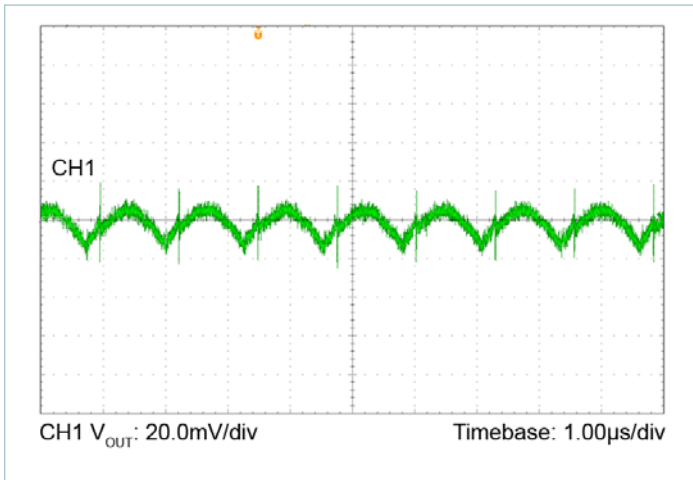

Figure 6 — Output ripple: 24V_{IN}, 5.0V_{OUT} at 7.5A

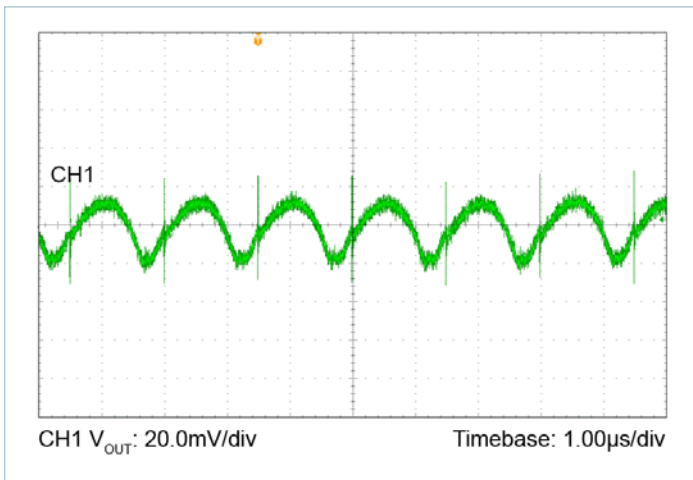

Figure 7 — Output ripple: 24V_{IN}, 5.0V_{OUT} at 15A

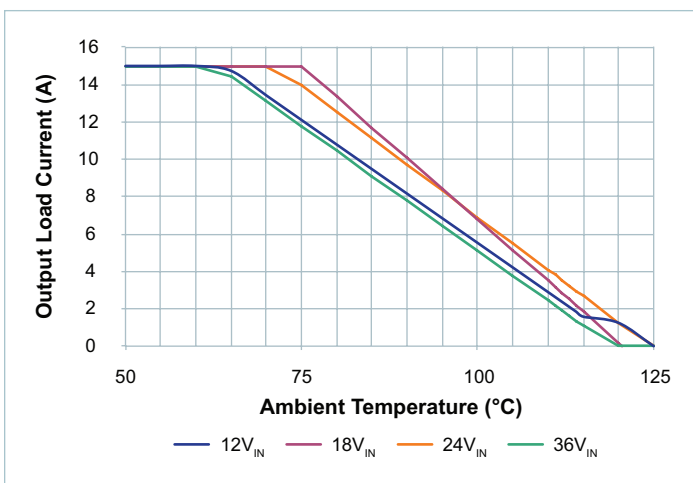

Figure 8 — Load current vs. ambient temperature, 0LFM

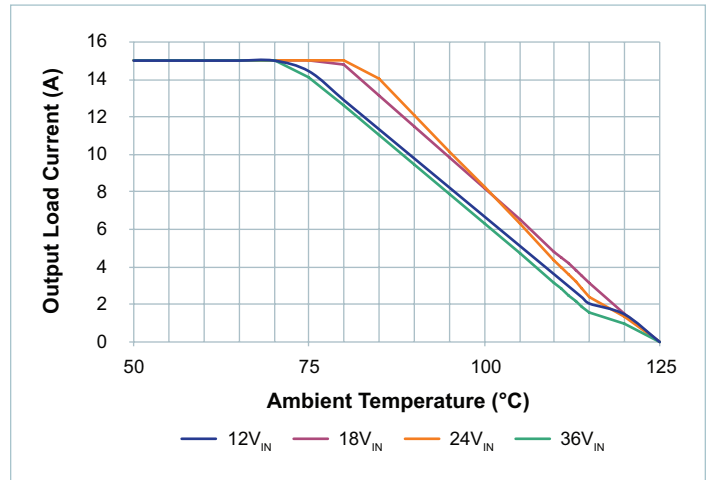

Figure 9 — Load current vs. ambient temperature, 200LFM

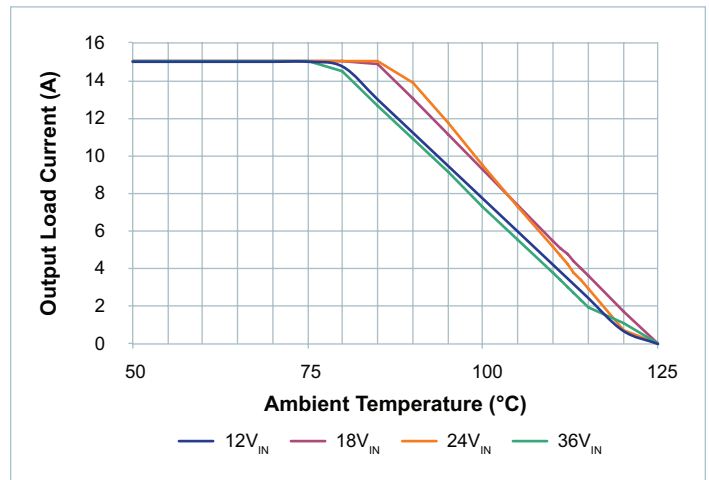

Figure 10 — Load current vs. ambient temperature, 400LFM

Functional Description

The PI3302-03 is a highly integrated ZVS Buck regulator. The PI3302-03 has a set output voltage that can be trimmed within a prescribed range shown on page 1. Performance and maximum output current are characterized with a specific external power inductor (see Table 4).

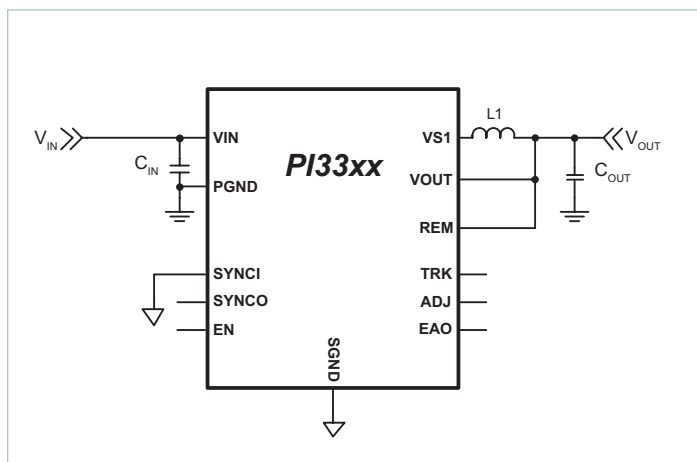

Figure 11 — ZVS Buck with required components

For basic operation, Figure 11 shows the connections and components required. No additional design or settings are required.

ENABLE (EN)

EN is the enable pin of the converter. The EN Pin is referenced to SGND and permits the user to turn the regulator on or off. The EN default polarity is a positive logic assertion. If the EN pin is left floating or asserted high, the converter output is enabled. Pulling EN pin below $0.8V_{DC}$ with respect to SGND will disable the regulator output.

Remote Sensing

An internal 100Ω resistor is connected between REM pin and VOUT pin to provide regulation when the REM connection is broken. Referring to Figure 11, it is important to note that L1 and C_{OUT} are the output filter and the local sense point for the power supply output. As such, the REM pin should be connected at C_{OUT} as the default local sense connection unless remote sensing to compensate additional distribution losses in the system. The REM pin should not be left floating.

Switching Frequency Synchronization

The SYNCI input allows the user to synchronize the controller switching frequency by an external clock referenced to SGND. The external clock can synchronize the unit between 50% and 110% of the preset switching frequency (f_s). The PI3302-03 default for SYNCI is to sync with respect to the falling edge of the applied clock providing 180° phase shift from SYNCO. This allows for the paralleling of two PI3302-03 devices without the need for further user programming or external sync clock circuitry.

When using the internal oscillator, the SYNCO pin provides a 5V clock that can be used to sync other regulators. Therefore, one PI3302-03 can act as the lead regulator and have one additional PI3302-03 running in parallel and interleaved.

Soft Start

The PI3302-03 includes an internal soft-start capacitor to control the rate of rise of the output voltage. See “Electrical Characteristics” for the default value. Connecting an external capacitor from the TRK pin to SGND will increase the start-up ramp period. See, “Soft Start Adjustment and Track,” in the Applications Description section for more details.

Output Voltage Trim

The PI3302-03 output voltage can be trimmed up from the preset output by connecting a resistor from ADJ pin to SGND and can be trimmed down by connecting a resistor from ADJ pin to VOUT. The Table 1 defines the voltage range for the PI3302-03.

Device	Output Voltage	
	Set	Range
PI3302-03-LGIZ	5.0V	3.3 – 6.5V

Table 1 — PI3302-03 output adjustment range

Output Current Limit Protection

PI3302-03 has two methods implemented to protect from output short or over current condition.

Slow Current Limit protection: prevents the output load from sourcing current higher than the regulator’s maximum rated current. If the output current exceeds the Current Limit (I_{OUT_CL}) for $1024\mu s$, a slow current-limit fault is initiated and the regulator is shut down which eliminates output current flow. After Fault Restart Delay (t_{FR_DLY}), a soft-start cycle is initiated. This restart cycle will be repeated indefinitely until the excessive load is removed.

Fast Current Limit protection: PI3302-03 monitors the regulator inductor current pulse-by-pulse to prevent the output from supplying very high current due to sudden low impedance short. If the regulator senses a high inductor current pulse, it will initiate a fault and stop switching until Fault Restart Delay ends and then initiate a soft-start cycle.

Input Undervoltage Lockout

If V_{IN} falls below the input Undervoltage Lockout (UVLO) threshold, but remains high enough to power the internal bias supply, the PI3302-03 will complete the current cycle and stop switching. The system will restart once the input voltage is reestablished and after the Fault Restart Delay.

Input Overvoltage Lockout

If V_{IN} exceeds the input Overvoltage Lockout (OVLO) threshold (V_{OVLO}), while the controller is running, the PI3302-03 will complete the current cycle and stop switching. The system will resume operation after the Fault Restart Delay.

Output Overvoltage Protection

The PI3302-03 is equipped with output Overvoltage Protection (OVP) to prevent damage to input voltage sensitive devices. If the output voltage exceeds 20% of its set regulated value, the regulator will complete the current cycle, stop switching and issue an OVP fault. The system will resume operation once the output voltage falls below the OVP threshold and after Fault Restart Delay.

Overtemperature Protection

The internal package temperature is monitored to prevent internal components from reaching their thermal maximum. If the Overtemperature Protection Threshold (OTP) is exceeded (T_{OTP}), the regulator will complete the current switching cycle, enter a low-power mode, set a fault flag, and will soft start when the internal temperature falls below Overtemperature Restart Hysteresis (T_{OTP_HYS}).

Pulse Skip Mode (PSM)

PI3302-03 features a PSM to achieve high efficiency at light loads. The regulators are setup to skip pulses if EAO falls below a PSM threshold. Depending on conditions and component values, this may result in single pulses or several consecutive pulses followed by skipped pulses. Skipping cycles significantly reduces gate drive power and improves light-load efficiency. The regulator will leave PSM once the EAO rises above the Skip Mode threshold.

Variable Frequency Operation

Each PI3302-03 is preprogrammed to a base operating frequency, with respect to the power stage inductor (see Table 3), to operate at peak efficiency across line and load variations. At low-line and high-load applications, the base frequency will decrease to accommodate these extreme operating ranges. By stretching the frequency, the ZVS operation is preserved throughout the total input line voltage range therefore maintaining optimum efficiency.

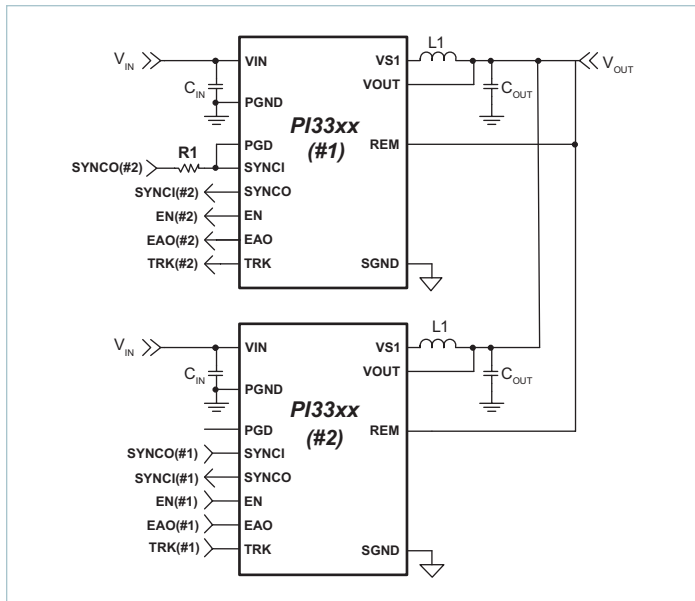

Figure 12 — PI3302-03 parallel operation

Parallel Operation

Paralleling modules can be used to increase the output current capability of a single power rail and reduce output voltage ripple.

The PI3302-03 default for SYNCI is to sync with respect to the falling edge of the applied clock providing 180° phase shift from SYNCO. This allows for the paralleling of two PI3302-03 devices without the need for further user programming or external sync clock circuitry.

By connecting the EAO pins and SGND pins of each module together the units will share the current equally. When the TRK pins of each unit are connected together, the units will track each other during soft-start and all unit EN pins have to be released to allow the units to start (See Figure 12). Also, any fault event in any regulator will disable the other regulators. The two regulators will be out of phase with each other reducing output ripple (refer to Switching Frequency Synchronization).

To provide synchronization between regulators over the entire operational frequency range, the Power Good (PGD) pin must be connected to the lead regulator’s (#1) SYNCI pin and a 2.5kΩ Resistor, R1, must be placed between SYNCO (#2) return and the lead regulator’s SYNCI (#1) pin, as shown in Figure 12. In this configuration, at system soft-start, the PGD pin pulls SYNCI low forcing the lead regulator to initialize the open-loop startup synchronization. Once the regulators reach regulation, SYNCI is released and the system is now synchronized in a closed-loop configuration which allows the system to adjust on the fly when any of the individual regulators begin to enter variable frequency mode in the loop.

Application Description

Output Voltage Trim

With a single resistor connected from the ADJ pin to SGND or REM, a device’s output can be varied above or below the nominal set voltage. The remote pin (REM) should always be connected to the V_{OUT} pin, if not used, to prevent an output voltage offset. Figure 13 shows the internal feedback voltage divider network.

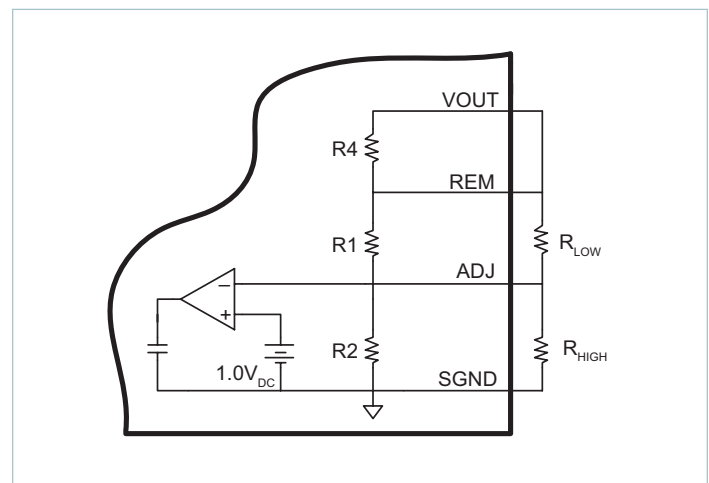

Figure 13 — Internal resistor divider network

R1, R2, and R4 are all internal 1.0% resistors and R_{LOW} and R_{HIGH} are external resistors which the designer can add to modify V_{OUT} to a desired output. The internal resistor value for each regulator is listed below in Table 2.

Conditions	R1	R2	R4
PI3302-03-LGIZ	4.53kΩ	1.13kΩ	100Ω

Table 2 — PI3302-03 internal divider values

By choosing an output voltage value within the ranges stated in Table 1, V_{OUT} can simply be adjusted up or down by selecting the proper R_{HIGH} or R_{LOW} value, respectively. The following equations can be used to calculate R_{HIGH} and R_{LOW} values:

$$R_{HIGH} = \frac{1}{\left(\frac{V_{OUT} - 1}{R1}\right) - \frac{1}{R2}} \quad (1)$$

$$R_{LOW} = \frac{1}{\frac{1}{R2(V_{OUT} - 1)} - \left(\frac{1}{R1}\right)} \quad (2)$$

Soft Start Adjust and Tracking

The TRK pin offers a means to increase the regulator’s soft-start time or to track with additional regulators. The soft-start slope is controlled by an internal capacitor and a fixed charge current to provide a Soft-Start Time t_{SS} for all PI3302-03 regulators. By adding an additional external capacitor to the TRK pin, the soft-start time can be increased further. The following equation can be used to calculate the proper capacitor for a desired soft-start times:

$$C_{TRK} = (t_{TRK} \cdot I_{TRK}) - 100 \cdot 10^{-9} \quad (3)$$

Where t_{TRK} is the soft-start time and I_{TRK} is a 50μA internal charge current (see Electrical Characteristics for limits).

There is typically either proportional or direct tracking implemented within a design. For proportional tracking between several regulators at start up, simply connect all PI3302-03 device TRK pins together. This type of tracking will force all connected regulators to startup and reach regulation at the same time (see Figure 14).

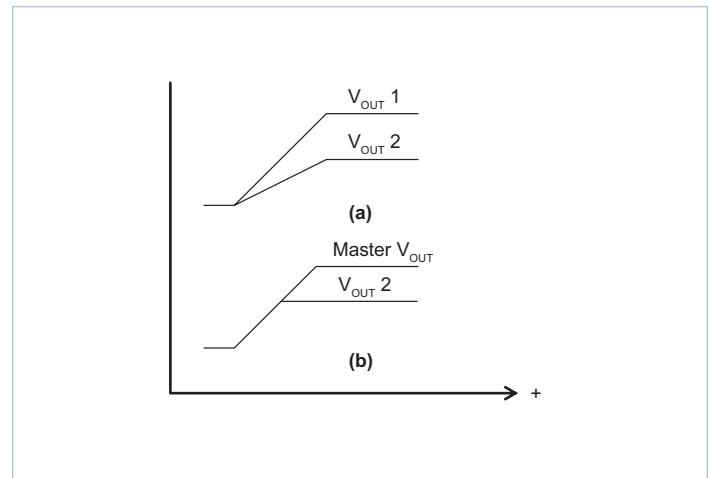

Figure 14 — PI3302-03 tracking methods

For Direct Tracking, choose the PI3302-03 or power supply with the highest output voltage as the parent and connect the parent output voltage to the TRK pin of the other PI3302-03 regulator(s) through a divider (Figure 15) with the same ratio as the child’s feedback divider (see Table 2 for values).

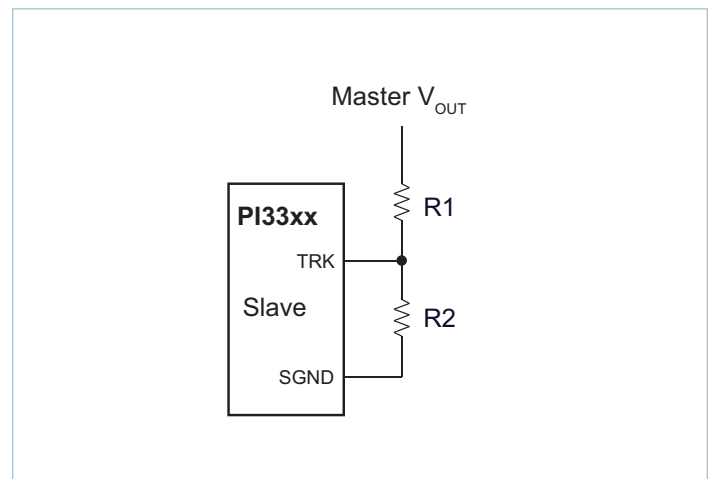

Figure 15 — Voltage divider connections for direct tracking

All connected PI3302-03 regulator soft-start slopes will track with this method. Direct tracking timing is demonstrated in Figure 14b. All tracking regulators should have their Enable (EN) pins connected together to work properly.

Inductor Pairing

The PI3302-03 utilizes an external inductor. This inductor has been optimized for maximum efficiency performance. Table 3 details the specific inductor value and part number utilized for the PI3302-03 device and is available from Eaton Corp.

Device	Inductor (nH)	Inductor Part Number	Manufacturer
PI3302-03	185	FP1507R1-R185-R	Eaton Corp.

Table 3 — PI3302-03 inductor pairing

Thermal De-rating

Thermal de-rating curves are provided that are based on component temperature changes versus load current, input voltage and air flow. It is recommended to use these curves as a guideline for proper thermal de-rating. These curves represent the entire system and are inclusive to both the Vicor regulator and the external inductor. Maximum thermal operation is limited by either the MOSFETs or inductor depending upon line and load conditions.

Thermal measurements were made using a standard PI3302-03 Evaluation board which is 3x4 inches in area and uses 4-layer, 2oz copper. Thermal measurements were made on the three main power devices, the two internal MOSFETs and the external inductor, with air flows of 0, 200 and 400LFM.

I²C™ Operation

The PI3302-03 provides an I²C digital interface that enables the user to program EN pin polarity, frequency synchronization phase/delay, dynamic margining and fault monitoring. The fault telemetry that can be monitored is:

- Input under and overvoltage (UV/OV)
- Output voltage too high
- Fast and slow current limit
- Overtemperature protection

Please refer to PI33xx I²C Digital Interface Guide for details.

Filter Considerations

The PI3302-03 requires low impedance ceramic X5R input capacitors to ensure proper start up and high-frequency decoupling for the power stage. The PI3302-03 will draw nearly all of the high-frequency current from the low-impedance ceramic capacitors when the main high-side MOSFET is conducting. During the time the high-side MOSFET is off, they are replenished from the source. If the source impedance is high at the switching frequency of the converter, a bulk capacitor may be necessary. This value has been chosen to be 100μF so that the PI3302-03 can start up into a full resistive load and supply the output capacitive load with the default minimum soft-start capacitor when the input source impedance is 50Ω at 1MHz. If it is used, it should be decoupled from the ceramic capacitors using a 200nH inductor rated for the maximum input current. A parallel damping resistor of 1Ω is also recommended. Table 4 shows the recommended input and output capacitors to be used for the PI3302-03 as well as expected transient response, RMS ripple currents per capacitor, and input and output ripple voltages. Table 5 includes the recommended input and output ceramic capacitors.

Device	V _{IN} (V)	I _{LOAD} (A)	C _{INPUT} Ceramic X5R	C _{INPUT} Bulk Elec.	C _{OUTPUT} Ceramic X5R	C _{INPUT} Ripple Current (I _{RMS})	C _{OUTPUT} Ripple Current (I _{RMS})	Input Ripple (mVpp)	Output Ripple (mVpp)	Transient Deviation (mVpk)	Recovery Time (μs)	Load Step (A) (Slew/μs)
PI3302-03	24	15	4 x 10μF 50V	100μF 50V	6 x 47μF	1.2	1.5	220	60	±170	30	7.5 (5A/μs)

Table 4 — Recommended input and output capacitance

Part Number	Description	Part Number	Description
GRM188R71C105KA12D - Murata	1μF 16V 0603 X7R	C3216X5R1H106K160AB - TDK	10μF 50V 1206 X7R
GRM319R71H104KA01D - Murata	0.1μF 50V 1206 X7R	GRM31CR61A476ME15L - Murata	47μF 10V 1206 X5R

Table 5 — Recommended capacitor types

Layout Guidelines

To optimize maximum efficiency and low-noise performance from a PI3302-03 design, layout considerations are necessary. Reducing trace resistance and minimizing high-current loop returns along with proper component placement will contribute to optimized performance.

A typical buck converter circuit is shown in Figure 16. The potential areas of high parasitic inductance and resistance are the circuit return paths, shown as LR below.

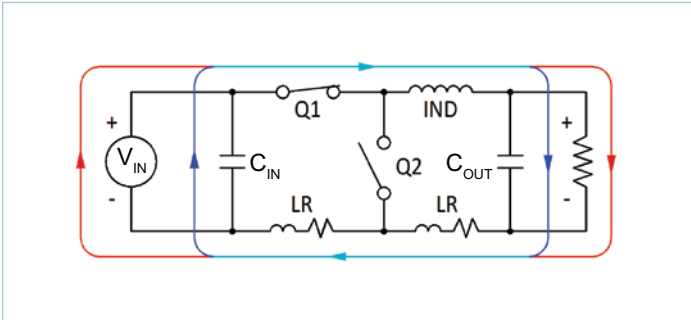

Figure 16 — Typical buck converter

The path between the C_{OUT} and C_{IN} capacitors is of particular importance since the AC currents are flowing through both of them when Q1 is turned on. Figure 17, schematically, shows the reduced trace length between input and output capacitors. The shorter path lessens the effects that copper trace parasitics can have on the PI3302-03 performance.

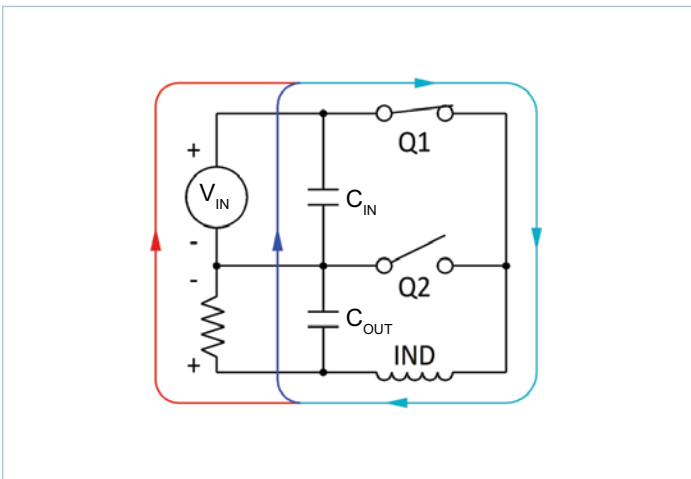

Figure 17 — Current flow: Q1 closed

When Q1 is on and Q2 is off, the majority of C_{IN} 's current is used to satisfy the output load and to recharge the C_{OUT} capacitors. When Q1 is off and Q2 is on, the load current is supplied by the inductor and the C_{OUT} capacitor as shown in Figure 18. During this period C_{IN} is also being recharged by the V_{IN} . Minimizing C_{IN} loop inductance is important to reduce peak voltage excursions when Q1 turns off. Also, the difference in area between the C_{IN} loop and C_{OUT} loop is vital to minimize switching and GND noise.

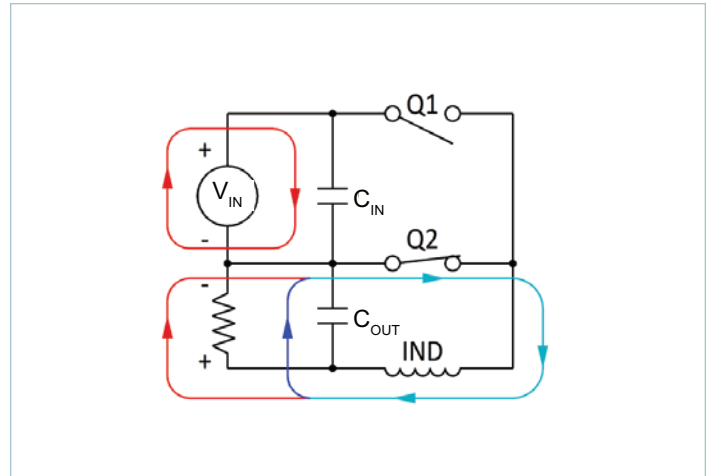

Figure 18 — Current flow: Q2 closed

The recommended component placement, shown in Figure 19, illustrates the tight path between C_{IN} and C_{OUT} (and V_{IN} and V_{OUT}) for the high AC return current. This optimized layout is used on the PI3302-03 evaluation board.

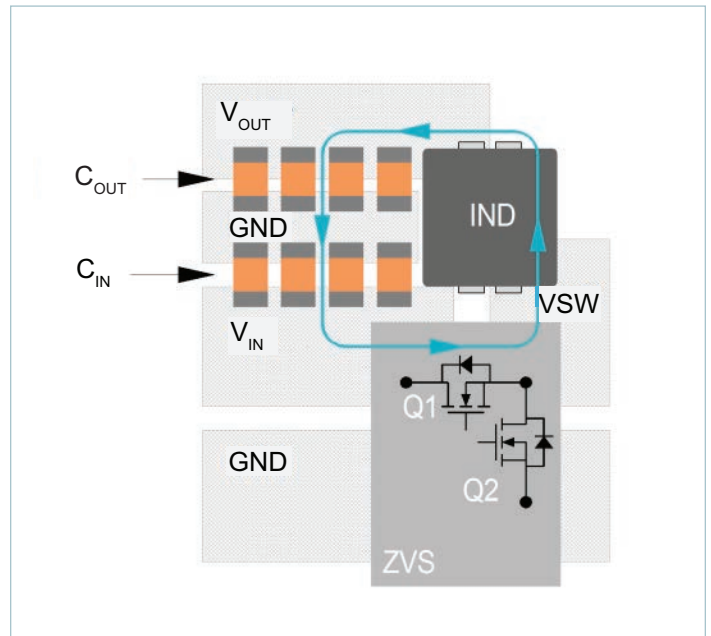
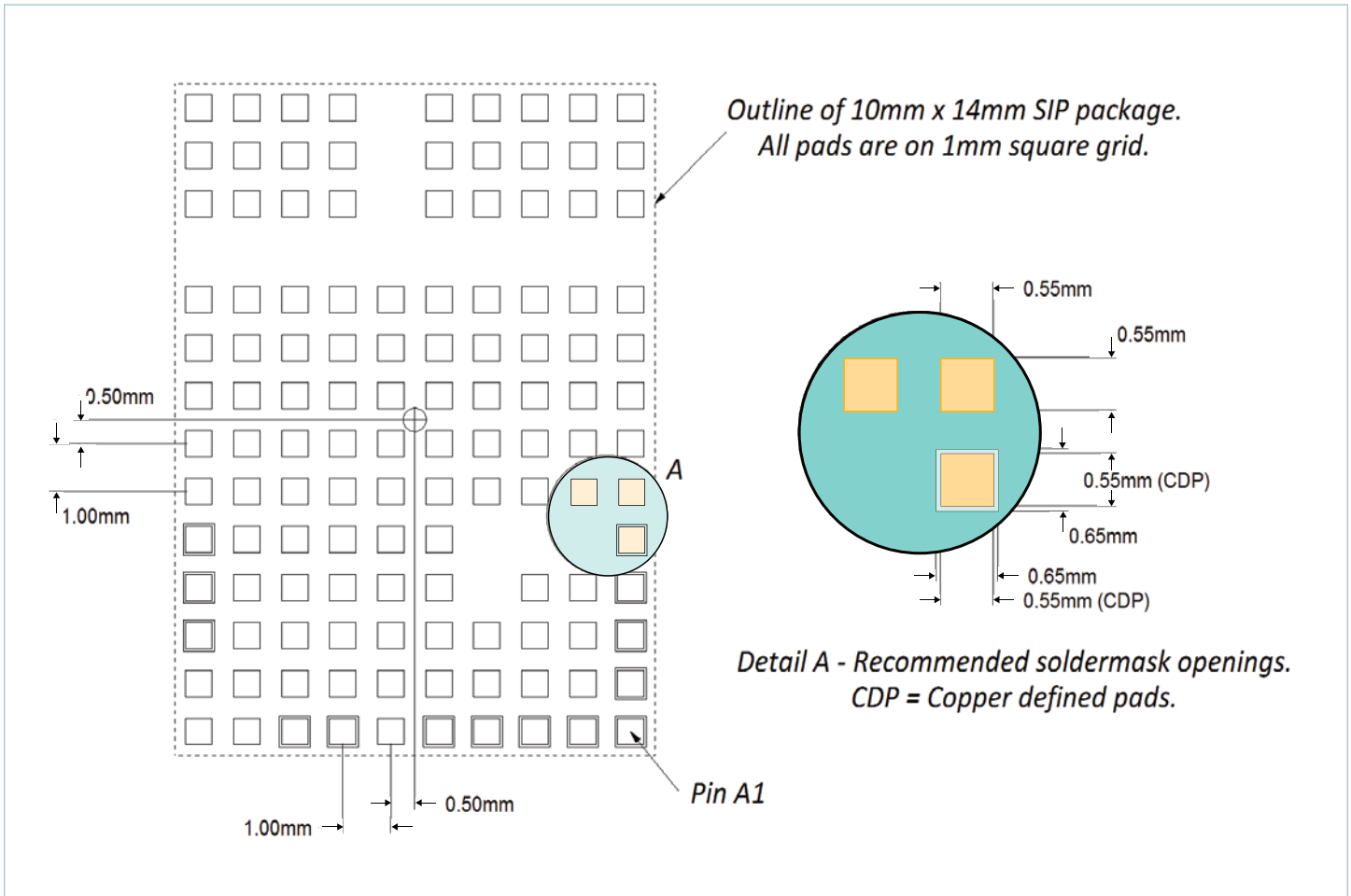

Figure 19 — Recommended component placement and metal routing

Recommended PCB Footprint and Stencil



Recommended receiving footprint for PI3302-03 10 x 14mm package. All pads should have a final copper size of 0.55 x 0.55mm, whether they are solder-mask defined or copper defined, on a 1 x 1mm grid. All stencil openings are 0.45mm when using either a 5 or 6mil stencil.

Package Drawings

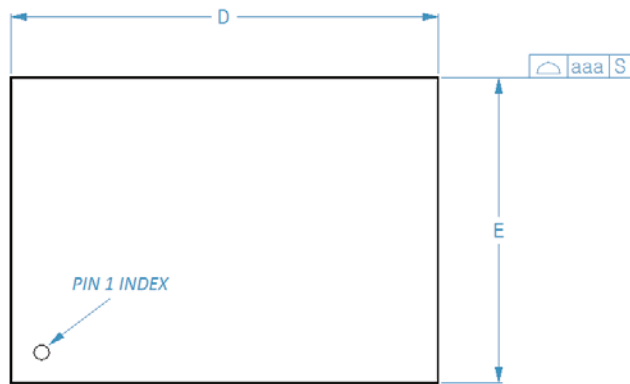

TOP VIEW

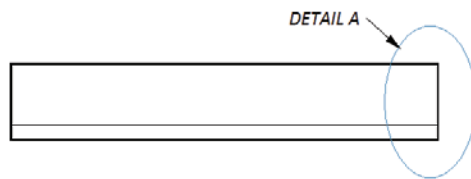

SIDE VIEW

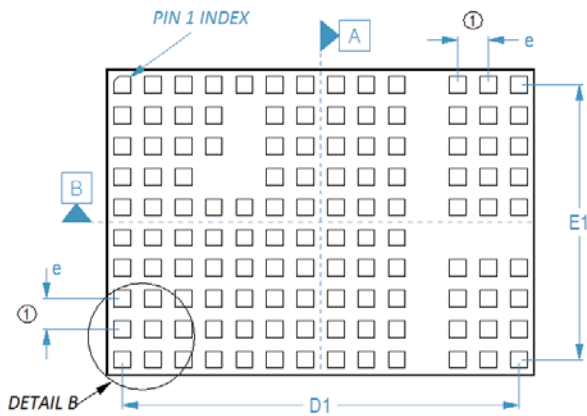

BOTTOM VIEW

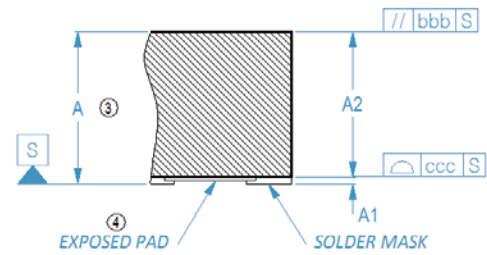

DETAIL A

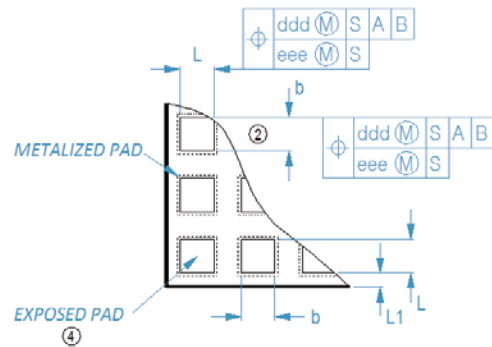

DETAIL B

DIMENSIONAL REFERENCES

REF.	MIN	NOM	MAX
A	2.50	2.56	2.62
A1	---	---	0.05
A2	---	---	2.57
b	0.50	0.55	0.60
L	0.50	0.55	0.60
D	14.00 BSC		
E	10.00 BSC		
D1	13.00 BSC		
E1	9.00 BSC		
e	1.00 BSC		
L1	0.10	0.15	0.20
aaa			0.10
bbb			0.10
ccc			0.08
ddd			0.10
eee			0.08

Notes :

- ① 'e' REPRESENTS THE BASIC TERMINAL PITCH. SPECIFIES THE TRUE GEOMETRIC POSITION OF THE TERMINAL AXIS.
- ② DIMENSION 'b' APPLIES TO METALLIZED TERMINAL AND IS MEASURED BETWEEN 0.00mm AND 0.25mm FROM TERMINAL TIP.
- ③ DIMENSION 'A' INCLUDES PACKAGE WARPAGE.
- ④ EXPOSED METALLIZED PADS ARE CU PADS WITH SURFACE FINISH PROTECTION.
5. ALL DIMENSIONS ARE IN MILLIMETERS.

Revision History

Revision	Date	Description	Page Number(s)
1.0	05/05/16	Initial Release	n/a
1.1	05/13/16	Change PGD description	4 & 10
1.2	02/28/17	Figure 2 update Format update	7 all
1.3	08/07/20	Updated terminology	12
1.4	12/02/20	Revised values for ceramic capacitors C_{INPUT} and C_{OUTPUT}	13

Note: page added in Rev 1.3.

Vicor's comprehensive line of power solutions includes high density AC-DC and DC-DC modules and accessory components, fully configurable AC-DC and DC-DC power supplies, and complete custom power systems.

Information furnished by Vicor is believed to be accurate and reliable. However, no responsibility is assumed by Vicor for its use. Vicor makes no representations or warranties with respect to the accuracy or completeness of the contents of this publication. Vicor reserves the right to make changes to any products, specifications, and product descriptions at any time without notice. Information published by Vicor has been checked and is believed to be accurate at the time it was printed; however, Vicor assumes no responsibility for inaccuracies. Testing and other quality controls are used to the extent Vicor deems necessary to support Vicor's product warranty. Except where mandated by government requirements, testing of all parameters of each product is not necessarily performed.

Specifications are subject to change without notice.

Visit <http://www.vicorpower.com/dc-dc-converters-board-mount/cool-power-pi33xx-and-pi34xx> for the latest product information.

Vicor's Standard Terms and Conditions and Product Warranty

All sales are subject to Vicor's Standard Terms and Conditions of Sale, and Product Warranty which are available on Vicor's webpage (<http://www.vicorpower.com/termsconditionswarranty>) or upon request.

Life Support Policy

VICOR'S PRODUCTS ARE NOT AUTHORIZED FOR USE AS CRITICAL COMPONENTS IN LIFE SUPPORT DEVICES OR SYSTEMS WITHOUT THE EXPRESS PRIOR WRITTEN APPROVAL OF THE CHIEF EXECUTIVE OFFICER AND GENERAL COUNSEL OF VICOR CORPORATION. As used herein, life support devices or systems are devices which (a) are intended for surgical implant into the body, or (b) support or sustain life and whose failure to perform when properly used in accordance with instructions for use provided in the labeling can be reasonably expected to result in a significant injury to the user. A critical component is any component in a life support device or system whose failure to perform can be reasonably expected to cause the failure of the life support device or system or to affect its safety or effectiveness. Per Vicor Terms and Conditions of Sale, the user of Vicor products and components in life support applications assumes all risks of such use and indemnifies Vicor against all liability and damages.

Intellectual Property Notice

Vicor and its subsidiaries own Intellectual Property (including issued U.S. and Foreign Patents and pending patent applications) relating to the products described in this data sheet. No license, whether express, implied, or arising by estoppel or otherwise, to any intellectual property rights is granted by this document. Interested parties should contact Vicor's Intellectual Property Department.

The products described on this data sheet are protected by U.S. Patents. Please see www.vicorpower.com/patents for the latest patent information.

Contact Us: <http://www.vicorpower.com/contact-us>

Vicor Corporation
25 Frontage Road
Andover, MA, USA 01810
Tel: 800-735-6200
Fax: 978-475-6715
www.vicorpower.com

email

Customer Service: custserv@vicorpower.com
Technical Support: apps@vicorpower.com

©2020 Vicor Corporation. All rights reserved. The Vicor name is a registered trademark of Vicor Corporation.

I²C™ is a trademark of NXP Semiconductors.

All other trademarks, product names, logos and brands are property of their respective owners.