

PFS1200-12-054xA

AC-DC Front End Power Supplies

The PFS1200-12-054xA is a 1200 Watt AC to DC power-factor-corrected (PFC) power supply that converts standard AC or HVDC power into a main output of 12 VDC for powering intermediate bus architectures (IBA) in high performance and reliability servers, routers, and network switches.

Displays the CE-Mark for the European Low Voltage Directive (LVD).



Key Features & Benefits

- High Efficiency, Meet 80Plus Platinum efficiency requirement
- Universal input voltage range: 90-264 VAC
- High voltage DC input: 180-400 VDC
- Always-On 24W standby output (12V/2A)
- Hot-plug capable
- Parallel operation with active digital current sharing
- Digital controls for improved performance
- High density design: 39 W/in³
- Small form factor (WxHxL): 54.5 x 40 x 228.6 mm (2.15 x 1.57 x 8.98 in)
- I2C communication interface for control, programming and monitoring with Power Management Bus protocol and PSMI Protocol
- Over temperature, output over voltage and overcurrent protection
- 256 Bytes of EEPROM for user information
- 2 Status LEDs: OK and FAIL with fault signaling
- Digital inrush current control

Applications

- High Performance Servers
- Routers
- Switches



bel POWER
SOLUTIONS &
PROTECTION

a bel group

belfuse.com/power-solutions

1. ORDERING INFORMATION

PFS	1200	-	12	-	054	x	A	x
Product Family	Power Level	Dash	V1 Output	Dash	Width	Airflow ¹	Input	Options
PFS Front-Ends	1200 W		12 V		54 mm	N: Normal R: Reverse	A: AC Input	blank: C14 Socket ² C: C16 Socket ² H: HVDC Socket ³

- ¹ N = Normal Airflow from Output connector to Input AC socket;
R = Reverse Airflow from Input AC socket to Output connector
- ² C14 / C16 AC input connector, input range 90 ~ 264 VAC and 180 ~ 350 VDC
- ³ Ordering PN: PFS1200-12-054NAH for both AC and HVDC (Anderson 2006G1-BK) input connector, input range is 180 ~ 400 VDC and 90 ~ 264 VAC

2. OVERVIEW

The PFS1200-12-054xA AC/DC power supply is with DSP control, high efficient front-end power supply. It incorporates resonance-soft-switching technology and interleaved power trains to reduce component stresses, providing increased system reliability and very high efficiency. With a wide input operational voltage range and minimal derating of output power with input voltage and temperature, the PFS1200-12-054xA power supply maximizes power availability in demanding server, network, and other high availability applications. The supply is fan cooled and ideally suited for integration with a matching airflow paths. Both the PFC stage and DC/DC stage is with DSP control. The DC/DC stage uses soft switching resonant techniques in conjunction with synchronous rectification. An active OR-ing device on the output ensures no reverse load current and renders the supply ideally suited for operation in redundant power systems. The always-on standby output, provides power to external power distribution and management controllers. It is protected with an active OR-ing device for maximum reliability. Status information is provided with front-panel LEDs. In addition, the power supply can be controlled and the fan speed set via the I2C bus. The I2C bus allows full monitoring of the supply, including input and output voltage, current, power, and inside temperatures. The fan speed is adjusted automatically depending on the actual power demand and supply temperature and can be overridden through the I2C bus.

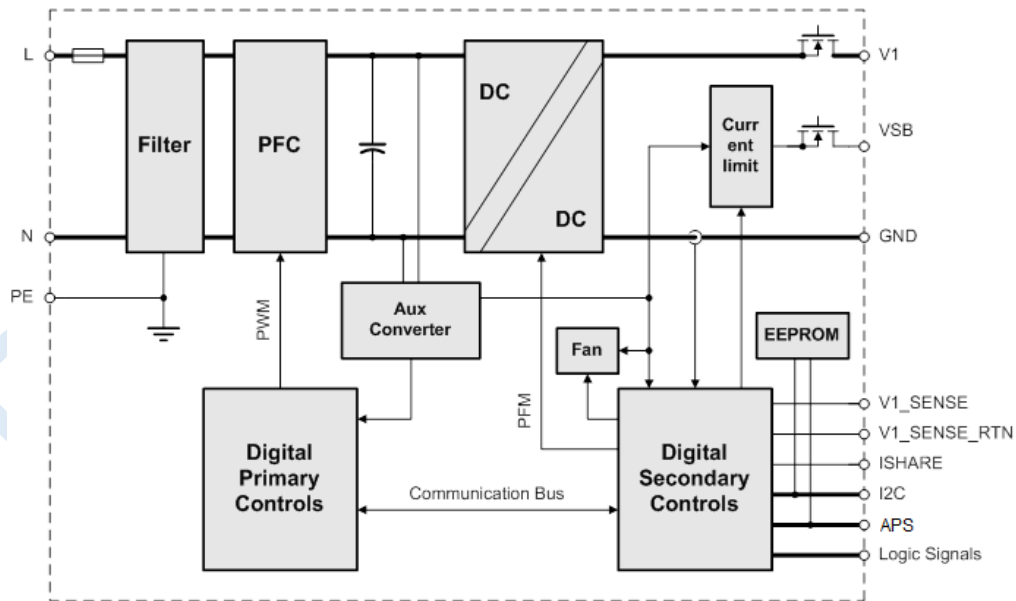

Figure 1. PFS1200-12-054NAH Series Block Diagram

3. ABSOLUTE MAXIMUM RATINGS

Stresses in excess of the absolute maximum ratings may cause performance degradation, adversely affect long-term reliability, and cause permanent damage to the supply.

PARAMETER	DESCRIPTION / CONDITION	MIN	NOM	MAX	UNIT
$V_{i\ maxc}$	Maximum Input	Continuous		264	VAC

4. INPUT SPECIFICATIONS

General Condition: $T_A = 0 \dots 50^\circ\text{C}$ unless otherwise specified.

PARAMETER	DESCRIPTION / CONDITION	MIN	NOM	MAX	UNIT
$V_{i\ nom}$	Nominal Input Voltage	100	115/230	240	VAC
			380	¹	VDC
V_i	Input Voltage Ranges	Normal operating ($V_{i\ min}$ to $V_{i\ max}$)		264	VAC
				400	VDC
$V_{i\ red}$	Derating Input Voltage Range	90		180	VAC
$I_{i\ max}$	Max Input Current			16	A_{rms}
$I_{i\ p}$	Inrush Current Limitation	$V_{i\ min}$ to $V_{i\ max}$, $T_{NTC} = 25^\circ\text{C}$		60	A_p
F_i	Input Frequency	47	50/60	63	Hz
PF	Power Factor	$V_{i\ nom}$, 50 Hz, $> 0.3 I_{i\ nom}$	0.95		WVA
$V_{i\ on}$	Turn-on Input Voltage ²	Ramping up	74	84	VAC
			170	180	VDC
$V_{i\ off}$	Turn-off Input Voltage	Ramping down	72	80	VAC
			170	175	VDC
		Input Out of Range	270	278	VAC
			402	410	VDC
η	Efficiency	$V_{i\ 115VAC}$, $0.2 \cdot k_{nom}$, $V_{x\ nom}$, $T_A = 25^\circ\text{C}$	90		
		$V_{i\ 115VAC}$, $0.5 \cdot k_{nom}$, $V_{x\ nom}$, $T_A = 25^\circ\text{C}$	92		
		$V_{i\ 115VAC}$, k_{nom} , $V_{x\ nom}$, $T_A = 25^\circ\text{C}$	89		
		$V_{i\ 230VAC}$, $0.2 \cdot k_{nom}$, $V_{x\ nom}$, $T_A = 25^\circ\text{C}$	90		
		$V_{i\ 230VAC}$, $0.5 \cdot k_{nom}$, $V_{x\ nom}$, $T_A = 25^\circ\text{C}$	94		
		$V_{i\ 230VAC}$, k_{nom} , $V_{x\ nom}$, $T_A = 25^\circ\text{C}$	91		
T_{hold}	Hold-up Time	$V_i = 90\text{Vac}$ to 264Vac , $V_1 \geq 11.4\text{V}$, $C_{out} = 5000\ \mu\text{F}$, 80% nominal output power, Time from de-assert INPUT_OK to Vout out of regulation or OUTPUT_OK de-asserts	5	10	ms

¹ For PFS1200-12-054NA and PFS1200-12-054NAC, Input HVDC range is 180 VDC to 350 VDC; input AC range is 90 VAC ~ 264 VAC.

² The Front-End is provided with a minimum hysteresis of 3 V during turn-on and turn-off within the ranges.

4.1 INPUT FUSE

Slow-acting 16 A input fuse (5 x 20 mm) in series the L line inside the power supply protect against severe defects. The fuse is not accessible from the outside and are therefore not serviceable parts.

4.2 INRUSH CURRENT

The AC-DC power supply exhibits low X-capacitance resulting in a low and short peak current, when the supply is connected to the mains. The internal bulk capacitor will be charged through an NTC which will limit the inrush current.

NOTE: Do not repeat plug-in / out operations within a short time, or else the internal in-rush current limiting device (NTC) may not sufficiently cool down and excessive inrush current or component failure(s) may result.

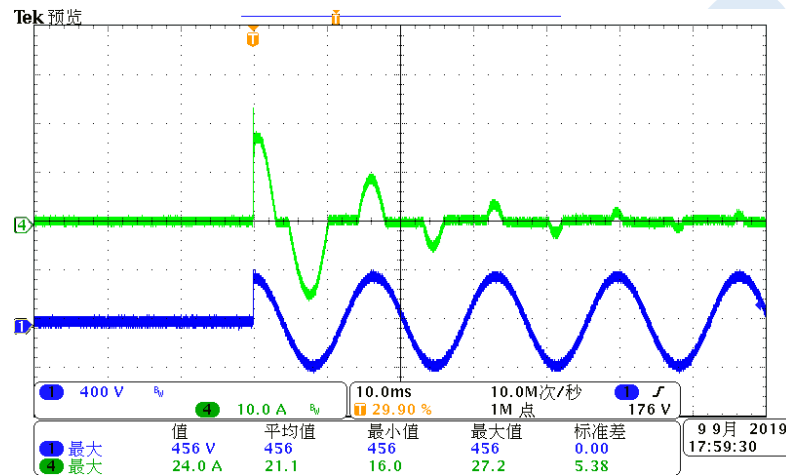

Figure 2. Inrush current, $V_{in} = 264V_{ac}$, 90°
CH1: V_{in} (400V/div), CH4: I_{in} (10A/div)

4.3 INPUT UNDER-VOLTAGE

If the sinusoidal input voltage stays below the input under voltage lockout threshold $V_{i on}$, the supply will be inhibited. Once the input voltage returns within the normal operating range, the supply will return to normal operation again.

4.4 POWER FACTOR CORRECTION

Power factor correction (PFC) is achieved by controlling the input current waveform synchronously with the input voltage. An analog controller is implemented giving outstanding PFC results over a wide input voltage and load ranges. The input current will follow the shape of the input voltage.

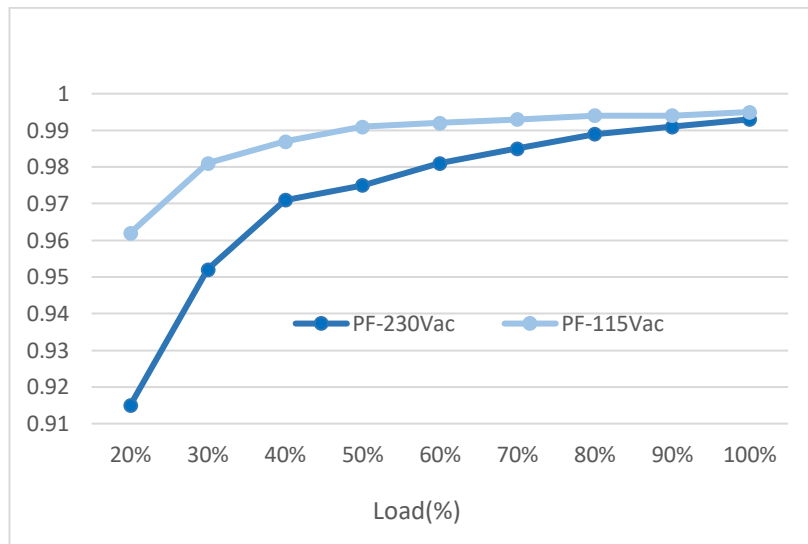

Figure 3. PF vs. Load

4.5 EFFICIENCY

High efficiency is achieved by using state-of-the-art silicon power devices in conjunction with soft-transition topologies minimizing switching losses and a full digital control scheme. Synchronous rectifiers on the output reduce the losses in the high current output path. The speed of the fan is digitally controlled to keep all components at an optimal operating temperature regardless of the ambient temperature and load conditions.

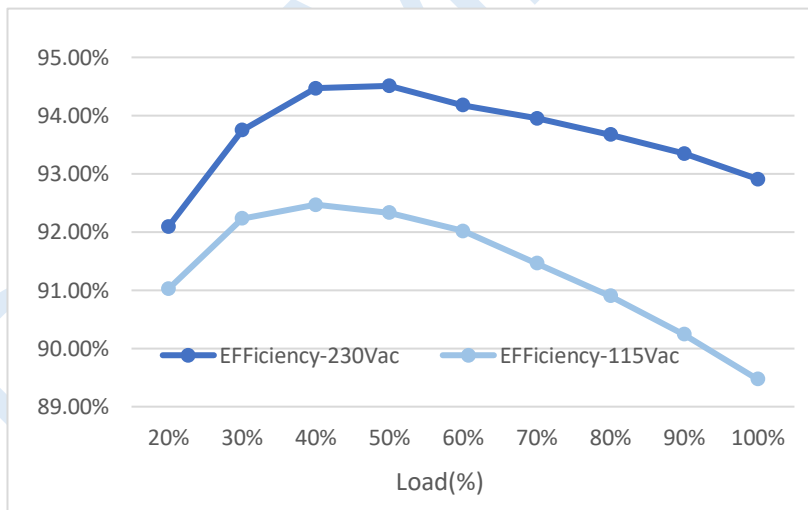

Figure 4. Efficiency vs. Load

5. OUTPUT SPECIFICATIONS

General Condition: $T_a = 0 \dots 50^\circ\text{C}$ unless otherwise specified.

PARAMETER	DESCRIPTION / CONDITION	MIN	NOM	MAX	UNIT
Main Output V_1					
$V_{1\text{ nom}}$	Nominal Output Voltage		12.0		VDC
$V_{1\text{ set}}$	Output Setpoint Accuracy	$0.5 \cdot I_{1\text{ nom}}, T_{\text{amb}} = 25^\circ\text{C}$		+0.5	% $V_{1\text{ nom}}$
$dV_{1\text{ tot}}$	Total Regulation	$V_{1\text{ min}}$ to $V_{1\text{ max}}, 0$ to 100% $I_{1\text{ nom}}, T_{\text{a min}}$ to $T_{\text{a max}}$		+2	% $V_{1\text{ nom}}$
$P_{1\text{ nom}}$	Nominal Output Power	264 VAC > $V_{1\text{ in}} \geq 180$ VAC, $V_1 = 12$ VDC 400 VDC > $V_{1\text{ in}} \geq 180$ VDC, $V_1 = 12$ VDC	1200		W
	Refer to Figure 3b/3c for derating curves	180 VAC > $V_{1\text{ in}} \geq 90$ VAC, $V_1 = 12$ VDC	1000		W
$I_{1\text{ nom}}$	Nominal Output Current	264 VAC > $V_{1\text{ in}} \geq 180$ VAC, $V_1 = 12$ VDC 400 VDC > $V_{1\text{ in}} \geq 180$ VDC, $V_1 = 12$ VDC	100		ADC
	Refer to Figure 3b/3c for derating curves	180 VAC > $V_{1\text{ in}} \geq 90$ VAC, $V_1 = 12$ VDC	83.33		ADC
$V_{1\text{ pp}}$	Output Ripple Voltage	$V_{1\text{ nom}}, 80\% I_{1\text{ nom}}, 20$ MHz BW (See Section 5.1)		100	mVpp
$dV_{1\text{ Load}}$	Load Regulation	$V_1 = V_{1\text{ nom}}, 0 - 100\% I_{1\text{ nom}}$	80		mV
$dV_{1\text{ Line}}$	Line Regulation	$V_1 = V_{1\text{ min}} \dots V_{1\text{ max}}$	40		mV
dI_{share}	Current Sharing	Deviation from $I_{1\text{ tot}} / N, I_1 > 10\%$	-5	+5	% $I_{1\text{ nom}}$
$dV_{1\text{ dyn}}$	Dynamic Load Regulation	$\Delta I_1 = 50\% I_{1\text{ nom}}, I_1 = 10 \dots 100\% I_{1\text{ nom}}, dI_1/dt = 1\text{A}/\mu\text{s}$	-0.6	0.6	V
T_{rec}	Recovery Time	$\Delta I_1 = 50\% I_{1\text{ nom}}, I_1 = 10 \dots 100\% I_{1\text{ nom}}, dI_1/dt = 1\text{A}/\mu\text{s}, \text{recovery within } 1\% \text{ of } V_{1\text{ nom}}$		2	ms
$t_{\text{AC } V_1}$	Start-up Time from AC			3	sec
$t_{V_1\text{ rise}}$	Rise Time	$V_1 = 10 \dots 90\% V_{1\text{ nom}}$	0.5	10	ms
C_{Load}	Capacitive Loading	$T_a = 25^\circ\text{C}$	1000	20000	μF
12 V_{SB} Standby Output					
$V_{\text{SB nom}}$	Nominal Output Voltage		12		VDC
$V_{\text{SB set}}$	Output Setpoint Accuracy	$0.5 \cdot I_{\text{SB nom}}, T_{\text{amb}} = 25^\circ\text{C}$		+1	% $V_{\text{SB nom}}$
$dV_{\text{SB tot}}$	Total Regulation	$V_{1\text{ min}}$ to $V_{1\text{ max}}, 0$ to 100% $I_{\text{SB nom}}, T_{\text{a min}}$ to $T_{\text{a max}}$		+3	% $V_{\text{SB nom}}$
$P_{\text{SB nom}}$	Nominal Output Power	$V_{\text{SB}} = 12$ VDC	24		W
$I_{\text{SB nom}}$	Nominal Output Current	$V_{\text{SB}} = 12$ VDC		2	A
$V_{\text{SB pp}}$	Output Ripple Voltage	$V_{\text{SB nom}}, I_{\text{SB nom}}, 20$ MHz BW (See Section 5.1)		120	mVpp
dV_{SB}	Droop	0 - 100 % $I_{\text{SB nom}}$	270		mV
$dV_{\text{SB dyn}}$	Dynamic Load Regulation	$\Delta I_{\text{SB}} = 50\% I_{\text{SB nom}}, I_{\text{SB}} = 5 \dots 100\% I_{\text{SB nom}}, dI_{\text{SB}}/dt = 1\text{A}/\mu\text{s}, \text{recovery within } 1\% \text{ of } V_{1\text{ nom}}$	-0.6	0.6	V
T_{rec}	Recovery Time			2	ms
$t_{\text{AC VSB}}$	Start-up Time from AC	$V_{\text{SB}} = 90\% V_{\text{SB nom}}$		2	s
$t_{V_{\text{SB}}\text{ rise}}$	Rise Time	$V_{\text{SB}} = 10 \dots 90\% V_{\text{SB nom}}$		20	ms
C_{Load}	Capacitive Loading	$T_{\text{amb}} = 25^\circ\text{C}$	100	1,500	μF

5.1 OUTPUT VOLTAGE RIPPLE

Internal capacitance at the 12 V output (behind the OR-ing circuitry) is minimized to prevent disturbances during hot plug. In order to provide low output ripple voltage in the application, external capacitors (a parallel combination of 10 μF low ESR capacitor in parallel with 0.1 μF ceramic capacitors) should be added close to the power supply output. The setup of *Figure* has been used to evaluate suitable capacitor types.

Table 1 and Table 2 should be used to reduce the output ripple voltage. The ripple voltage is measured with 20 MHz BWL, close to the external capacitors.

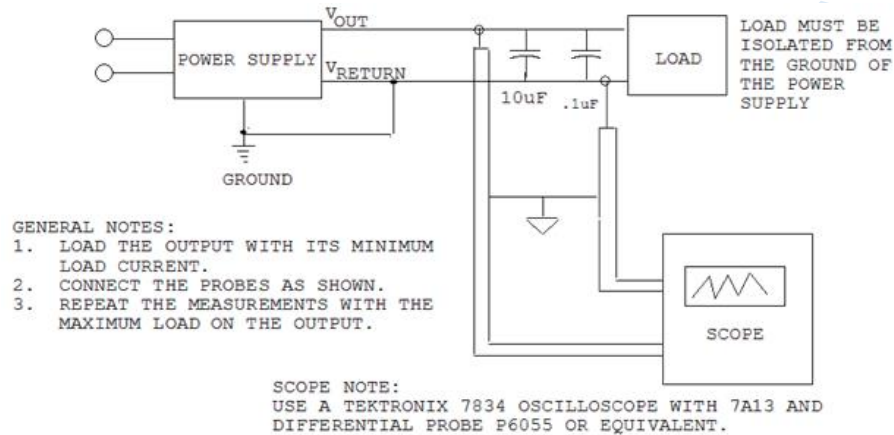

Figure 5. Output ripple test setup

NOTE: Care must be taken when using ceramic capacitors with a total capacitance of 1 μF to 50 μF on output V1, due to their high quality factor the output ripple voltage may be increased in certain frequency ranges due to resonance effects.

EXTERNAL CAPACITOR V1	DV1MAX	UNIT
Standard test condition: 1 Pc 10 μF / 63 V Electrolytic Capacitor 1 pc 0.1 μF / 100 V ceramic capacitor	120	mVpp
1Pcs 1000 μF /16V/Low ESR Aluminum/ \varnothing 10x20	100	mVpp
2Pcs 47 μF /16V/X5R/1210 plus 1Pcs 1000 μF /16V/Low ESR Aluminum/ \varnothing 10x20	80	mVpp

Table 1. Suitable capacitors for V1

EXTERNAL CAPACITOR VSB	DV1MAX	UNIT
Standard test condition: 1 pc 10 μF / 63 V Electrolytic Capacitor 1 pc 0.1 μF / 50V ceramic capacitor	120	mVpp
Add 1 pcs 10 μF /25 V/X7R/1206	100	mVpp
Add 2 pcs 10 μF /25V/X7R/1206	80	mVpp

Table 2. Suitable capacitors for VSB

The output ripple voltage on VSB is influenced by the main output V1. Evaluating VSB output ripple must be done when maximum load is applied to V1.

6. PROTECTION SPECIFICATIONS

PARAMETER	DESCRIPTION / CONDITION	MIN	NOM	MAX	UNIT
F	Input Fuse (L)	Not user accessible		16	A
$V_{1\text{OV}}$	OV Threshold V_1	13.3		14.5	VDC
$t_{\text{OV}V_1}$	OV Latch Off Time V_1			1	ms
$V_{\text{SB}OV}$	OV Threshold V_{SB}	13.3		14.5	VDC
$t_{\text{OV}V_{\text{SB}}}$	OV Latch Off Time V_{SB}		1		ms
$I_{1\text{lim}}$	Over Current Limitation V_1	$V_1 > 180\text{ VAC}, T_a < 50^\circ\text{C}$ $V_1 > 90\text{ VAC}, T_a < 50^\circ\text{C}$		110 140	A
$I_{\text{VSB}lim}$	Over Current Limitation V_{SB}	$T_a < 50^\circ\text{C}$ for 12 V_{SB}		2.2 2.6	A
$t_{V_1\text{SC}}$	Short Circuit Regulation Time	$V_1 < 3\text{ V}$, time until I_{V_1} is limited to $< 200\text{ A}$		2	ms
T_{SD}	Over Temperature on Heat Sinks	Automatic shut-down		115 120	$^\circ\text{C}$

6.1 OVERVOLTAGE PROTECTION

The PFS front-ends provide a fixed threshold overvoltage (OV) protection implemented with a HW comparator. Once an OV condition has been triggered, the supply will shut down and latch the fault condition. The latch can be unlocked by disconnecting the supply from the AC mains or by toggling the PSON_L input

6.2 UNDERVOLTAGE DETECTION

Both main and standby outputs are monitored. LED and PWOK_L pin signal if the output voltage exceeds $\pm 7\%$ of its nominal voltage. Output under voltage protection is provided on both outputs. When either V1 or VSB falls below 93% of its nominal voltage, the output is inhibited.

6.3 CURRENT LIMITATION

6.3.1 MAIN OUTPUT

When main output runs in current limitation mode its output will turn OFF below 2 V but will shut down after 6 attempts. If current limitation mode is still present after the unit retry, output will continuously perform this routine until current is below the current limitation point. The supply will go through soft start every time it retries from current limitation mode.

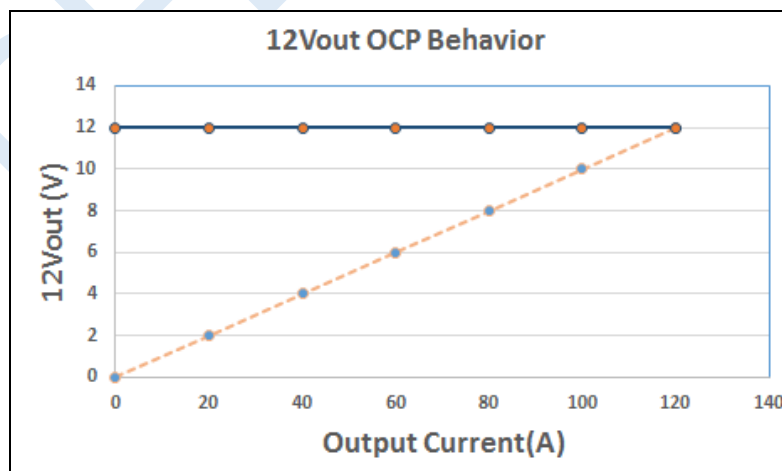

Figure 6a. Current Limitation on V_1 ($V_i = 230\text{ VAC}$)

The main output current and limitation will decrease if the ambient (inlet) temperature increases beyond 50°C; below are the derating curve for PFS1200-12-054NAH with input voltage above 180 VAC and applied in Canada and United States of America.

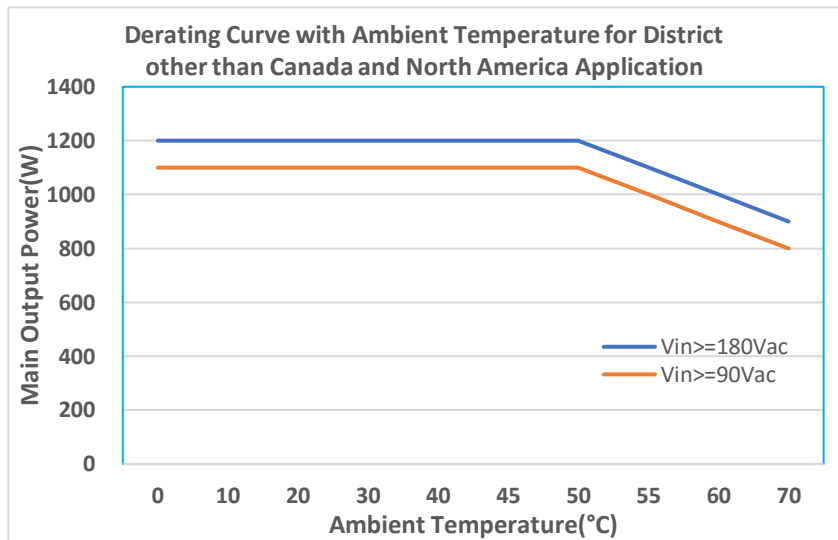

Figure 6b. I_{out} Derating Curve for ambient above 50°C

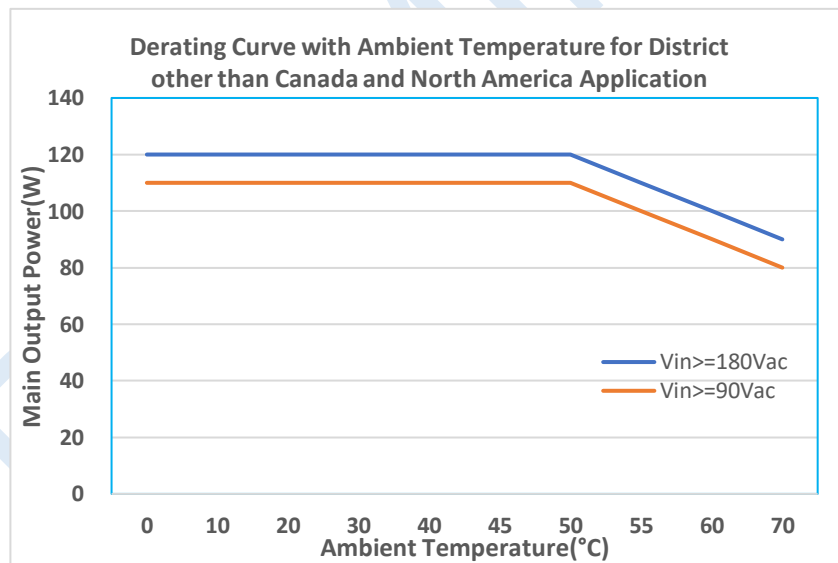

Figure 6c. OCP Derating Curve with Ambient Temperature

6.3.2 STANDBY OUTPUT

12 V_{SB}

On the standby output, a hiccup type over current protection is implemented. This protection will shut down the standby output immediately when standby current reaches or exceeds $I_{SB\ lim}$. After an off-time of 1 s the output automatically tries to restart. If the overload condition is removed the output voltage will reach again its nominal value. At continuous overload condition the output will repeatedly trying to restart with 1s intervals. A failure on the Standby output will shut down both Main and Standby outputs.

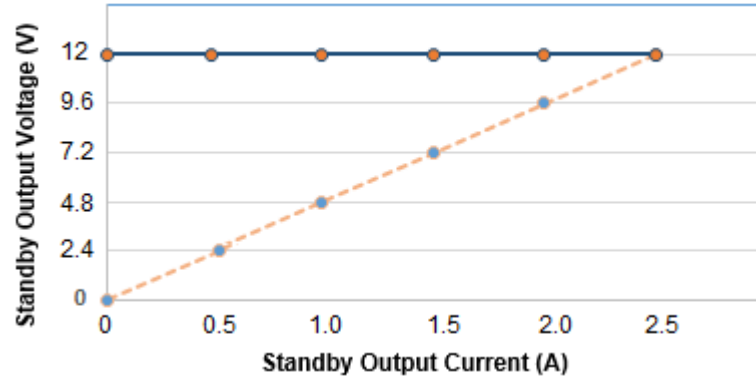

Figure 7. Current Limitation on 12 V_{SB}

7. MONITORING

PARAMETER	DESCRIPTION / CONDITION	MIN	NOM	MAX	UNIT
$V_{i\ mon}$	Input RMS Voltage $V_{i\ min} \leq V_i \leq V_{i\ max}$	-2.5		+2.5	%
$I_{i\ mon}$	Input RMS Current $I_i > 2 A_{rms}$	-5		+5	%
$P_{i\ mon}$	True Input Power $I_i > 2 A_{rms}$	-5		+5	%
$V_{1\ mon}$	V ₁ Voltage	-2		+2	%
$I_{1\ mon}$	V ₁ Current	$I_{11} > 25\ A$		+2	%
		$I_{11} \leq 25\ A$	-1		+1
$P_{o\ nom}$	Total Output Power	$P_o > 120\ W$		+5	%
		$P_o \leq 120\ W$	-12		+12
$V_{SB\ mon}$	Standby Voltage			+0.5	V
$I_{SB\ mon}$	Standby Current			+0.5	A

8. SIGNAL & CONTROL SPECIFICATIONS

8.1 ELECTRICAL CHARACTERISTICS

PARAMETER	DESCRIPTION / CONDITION	MIN	NOM	MAX	UNIT
PSKILL_H / PSON_L / HOTSTANDBYEN_H Inputs					
V_L	Input Low Level Voltage	-0.2		0.8	V
V_H	Input High Level Voltage	2.4		3.5	V
$I_{L,H}$	Maximum Input Sink or Source Current	0		1	mA
$R_{puPSKILL_H}$	Internal Pull Up Resistor on PSKILL_H		100		k Ω
R_{puPSON_L}	Internal Pull Up Resistor on PSON_L		10		k Ω
$R_{puHOTSTANDBYEN_H}$	Internal Pull Up Resistor on HOTSTANDBYEN_H		10		k Ω
R_{LOW}	Resistance Pin to SGND for Low Level	0		1	k Ω
R_{HIGH}	Resistance Pin to SGND for High Level	50			k Ω
PWOK_H Output					
V_{OL}	Output Low Level Voltage			0.4	V
					$I_{sink} < 4 \text{ mA}$
V_{OH}	Output High Level Voltage	2.6		3.5	V
					$I_{source} < 0.5 \text{ mA}$
R_{puPWOK_H}	Internal Pull Up Resistor on PWOK_H		1		k Ω
ACOK_H Output					
V_{OL}	Output Low Level Voltage			0.4	V
					$I_{sink} < 2 \text{ mA}$
V_{OH}	Output High Level Voltage	2.6		3.5	V
					$I_{source} < 50 \mu\text{A}$
R_{puACOK_H}	Internal Pull Up Resistor on ACOK_H		10		k Ω
SMB_ALERT_L Output					
V_{ext}	Maximum External Pull Up Voltage			12	V
V_{OL}	Output Low Level Voltage			0.4	V
					$I_{source} < 4 \text{ mA}$
I_{OH}	Maximum High Level Leakage Current			10	μA
$R_{puSMB_ALERT_L}$	Internal Pull Up Resistor on SMB_ALERT_L		None		k Ω

8.2 INTERFACING WITH SIGNALS

All signal pins have protection diodes implemented to protect internal circuits. When the power supply is not powered, the protection devices start clamping at signal pin voltages exceeding $\pm 0.5 \text{ V}$. Therefore, all input signals should be driven only by an open collector/drain to prevent back feeding inputs when the power supply is switched off. If interconnecting of signal pins of several power supplies is required, then this should be done by decoupling with small signal schottky diodes except for SMB_ALERT_L, ISHARE and I²C pins. SMB_ALERT_L pins can be interconnected without decoupling diodes, since these pins have no internal pull up resistor and use a 15 V zener diode as protection device against positive voltage on pins. ISHARE pins must be interconnected without any additional components. This in-/output is disconnected from internal circuits when the power supply is switched off.

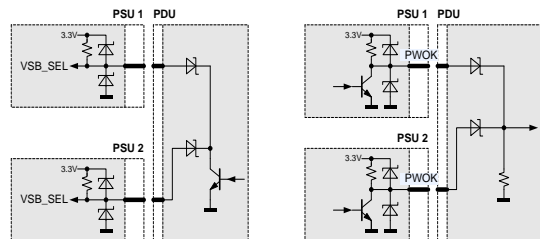

Figure 8. Interconnection of Signal Pins

8.3 FRONT LEDS

There will be 2 Bi-color (Green/ Amber) LED to indicate power supply status. The LED are visible on the power supply's exterior face. The LED location meets ESD Requirements. Following are these definitions as:

LED FUNCTION	COLOR	BRIGHTNESS
Input AC	Green (520 nm – 540 nm)	500-1000cd/m ²
Output DC/Fault	Green (520 nm – 540 nm) / Amber (520 nm – 540 nm) Amber (587 nm – 595 nm)	500-1000cd/m ²

COMMAND NAME	OUTPUT VOLTAGE STATUS		LED BEHAVIOR COLOR/BLINKING/SOLID/OFF	
CONDITION	VOUT (V)	VSTBY (V)	INPUT	OUTPUT/FAULT
VOUT Normal Operation	12.00	12.00	GREEN SOLID	GREEN SOLID
VOUT_OV_FAULT_LIMIT	0.00	12.00	GREEN SOLID	AMBER SOLID
VOUT_OV_WARN_LIMIT	13.5	12.00	GREEN SOLID	AMBER BLINKING
VSTBY_OV_FAULT_LIMIT	12.00	0.00	GREEN SOLID	AMBER SOLID
VSTBY_OV_WARN_LIMIT	12.00	13.5	GREEN SOLID	AMBER BLINKING
VOUT_UV_FAULT_LIMIT	0.00	12.00	GREEN SOLID	AMBER SOLID
VOUT_UV_WARN_LIMIT	11.40	12.00	GREEN SOLID	AMBER BLINKING
VSTBY_UV_FAULT_LIMIT	12.00	0.00	GREEN SOLID	AMBER SOLID
VSTBY_UV_WARN_LIMIT	12.00	11.00	GREEN SOLID	AMBER BLINKING
IOUT_OC_FAULT_LIMIT	0.00	12.00	GREEN SOLID	AMBER SOLID
IOUT_OC_WARN_LIMIT	12.00	12.00	GREEN SOLID	AMBER BLINKING
ISTBY_OC_FAULT_LIMIT	12.00	0.00	GREEN SOLID	AMBER SOLID
ISTBY_OC_WARN_LIMIT	12.00	12.00	GREEN SOLID	AMBER BLINKING
TEMPERATURE WARNING LIMIT	12.00	12.00	GREEN SOLID	AMBER BLINKING
TEMPERATURE FAULT LIMIT	0.00	12.00	GREEN SOLID	AMBER SOLID
VIN_OV_FAULT_LIMIT	0.00	12.00	GREEN BLINKING	AMBER SOLID
VIN_OV_WARN_LIMIT	12.00	12.00	GREEN BLINKING	AMBER BLINKING
VIN_UV_FAULT_LIMIT	0.00	0.00	OFF	OFF
VIN_UV_WARN_LIMIT	12.00	12.00	GREEN BLINKING	AMBER BLINKING
IIN_OC_FAULT_LIMIT	0.00	12.00	GREEN SOLID	AMBER SOLID
IIN_OC_WARN_LIMIT	12.00	12.00	GREEN SOLID	AMBER BLINKING
FAN_1_FAULT	0.00	12.00	GREEN SOLID	AMBER SOLID
FAN_1_WARNING	12.00	12.00	GREEN SOLID	AMBER BLINKING
IOUT SHORT CIRCUIT	0.00	12.00	GREEN SOLID	AMBER SOLID
ISTBY SHORT CIRCUIT	12.00	0.00	GREEN SOLID	AMBER SOLID
PS_ON High	0.00	12.00	GREEN SOLID	GREEN BLINKING
PS_Kill	0.00	0.00	GREEN SOLID	OFF

Table 3. LED Status

8.4 PRESENT_L

This signaling pin is recessed within the connector and will contact only once all other connector contacts are closed. This active-low pin is used to indicate to a power distribution unit controller that a supply is plugged in. The maximum current on PRESENT_L pin should not exceed 10 mA.

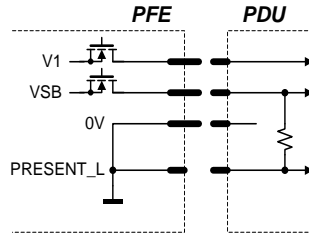

Figure 9. PRESENT_L signal pin

8.5 PSKILL_H INPUT

The PSKILL_H input is active-high and is located on a recessed pin on the connector and is used to disconnect the main output as soon as the power supply is being plugged out. This pin should be connected to SGND in the power distribution unit. The standby output will remain on regardless of the PSKILL_H input state.

8.6 AC TURN-ON / DROP-OUTS / ACOK_H

The power supply will automatically turn-on when connected to the AC line under the condition that the PSON_L signal is pulled low and the AC line is within range. The ACOK_H signal is active-high. See the timing diagram in Figure 8 and Table 4.

OPERATING CONDITION	MIN	MAX	UNIT
$t_{AC V_{SB}}$ AC Line to 90% V_{SB}		2	sec
$t_{AC V_1}$ AC Line to 90% V_1		2	sec
$t_{ACOK_H\ on1}$ ACOK_H signal on delay (start-up)		2000	ms
$t_{ACOK_H\ on2}$ ACOK_H signal on delay (dips)		100	ms
$t_{ACOK_H\ off}$ ACOK_H signal off delay		5	ms
$t_{V_{SB}\ V_1\ del}$ V_{SB} to V_1 delay	10	500	ms
$t_{V_1\ holdup}$ Effective V_1 holdup time	10		ms
$t_{V_{SB}\ holdup}$ Effective V_{SB} holdup time	20		ms
$t_{ACOK_H\ V_1}$ ACOK_H to V_1 holdup	7		ms
$t_{ACOK_H\ V_{SB}}$ ACOK_H to V_{SB} holdup	15		ms
$t_{V_1\ off}$ Minimum V_1 off time	1	2	sec
$t_{V_{SB}\ off}$ Minimum V_{SB} off time	1	2	sec

NOTE: AC short dips means below 10 ms;
AC long dips means 10 ms to 100 ms

Table 4. AC Turn-on / Dip Timing

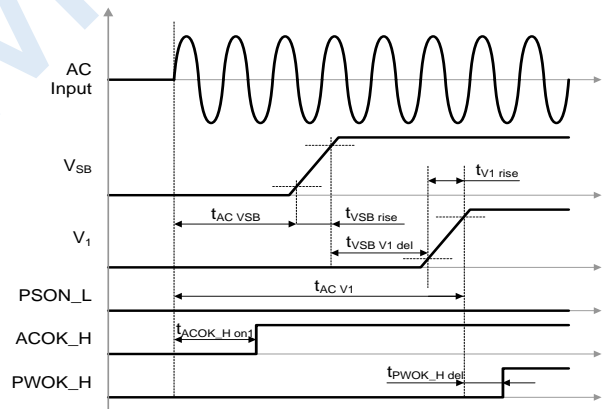

Figure 10. AC turn-on timing



Asia-Pacific
+86 755 298 85888

Europe, Middle East
+353 61 225 977

North America
+1 408 785 5200

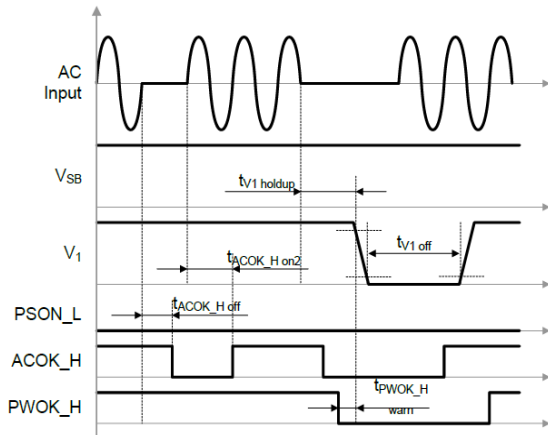

Figure 11. AC short dips

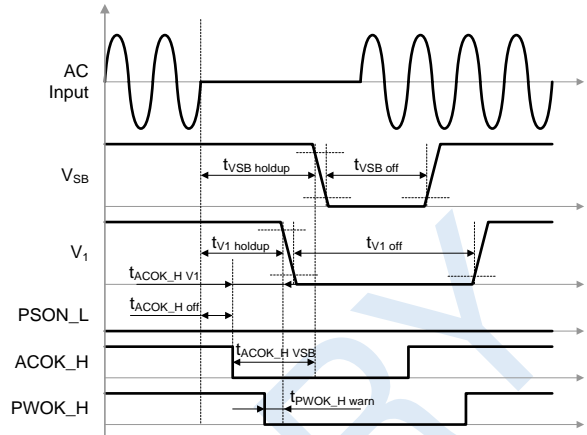

Figure 12. AC long dips

8.7 PSON_L INPUT

The PSON_L is an internally pulled-up (3.3 V) input signal to enable/disable the main output V1 of the front-end. This active-low pin is also used to clear any latched fault condition, see the parameters in Table 5.

OPERATING CONDITION		MIN	MAX	UNIT
$t_{PSON_L\ V1on}$	PSON_L to V1 delay (on)	2	20	ms
$t_{PSON_L\ V1off}$	PSON_L to V1 delay (off)	2	20	ms
$t_{PSON_L\ H\ min}$	PSON_L minimum High time	10		ms

Table 5. PSON_L timing

8.8 PWOK_H SIGNAL

The PWOK_H is an open drain output with an internal pull-up to 3.3 V indicating whether both Vsb and V1 outputs are within regulation. This pin is active-low. The timing diagram is shown in Figure 11 and referenced in the Table 6.

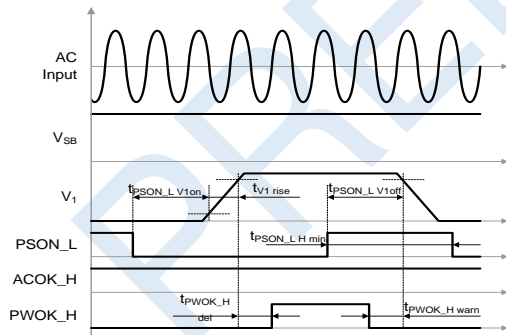

Figure 13. PSON_L and PWOK_H turn-on/off timing

OPERATING CONDITION		MIN	MAX	UNIT
$t_{PWOK_H\ del}$	PWOK_H to V1 delay (on)	100	500	ms
$t_{PWOK_H\ warn}^*$	PWOK_H to V1 delay (off) caused by: PSKILL_H	0	1	ms
	PSON_L, OT, Fan Failure	0.5	2.5	ms
	ACOK_H (time change with loading condition)	0.5	100	ms
	UV and OV on VSB	1	30	ms
	OC on V1 (Software trigger)	-11	0	ms
	OC on V1 (Hardware trigger)	-1	0	ms
	OV on V1	-3	0	ms

* A positive value means a warning time, a negative value a delay (after fact).

Table 6. PWOK_H timing

8.9 CURRENT SHARE

The PFS front-ends have an active current share scheme implemented for V₁. All the ISHARE current share pins need to be interconnected in order to activate the sharing function. If a supply has an internal fault or is not turned on, it will disconnect its ISHARE pin from the share bus. This will prevent dragging the output down (or up) in such cases.

The current share function uses an analog bi-directional data exchange on a recessive bus configuration to transmit and receive current share information. The controller implements a Master/Slave current share function. The power supply providing the largest current among the group is automatically the Master. The other supplies will operate as Slaves and increase their output current to a value close to the Master by slightly increasing their output voltage. The voltage increase is limited to +250 mV.

The standby output uses a passive current share method (droop output voltage characteristic).

8.10 SENSE INPUTS

Main output has sense lines implemented to compensate for voltage drop on load wires (no sense lines for 12VSB). The maximum allowed voltage drop is 200 mV on the positive rail and 100 mV on the PGND rail.

With open sense inputs the main output voltage will rise by 270 mV. Therefore, if not used, these inputs should be connected to the power output and PGND close to the power supply connector. The sense inputs are protected against short circuit. In this case the power supply will shut down.

8.11 HOT-STANDBY OPERATION

The hot-standby operation is an operating mode allowing to further increase efficiency at light load conditions in a redundant power supply system. Under specific conditions one of the power supplies is allowed to disable its DC/DC stage. This will save the power losses associated with this power supply and at the same time the other power supply will operate in a load range having a better efficiency. In order to enable the hot standby operation, the HOTSTANDBYEN_H and the ISHARE pins need to be interconnected. A power supply will only be allowed to enter the hot-standby mode, when the HOTSTANDBYEN_H pin is high, the load current is low and the supply was allowed to enter the hot-standby mode by the system controller via the appropriate I²C command (by default disabled). The system controller needs to ensure that only one of the power supplies is allowed to enter the hot-standby mode.

If a power supply is in a fault condition, it will pull low its active-high HOTSTANDBYEN_H pin which indicates to the other power supply that it is not allowed to enter the hot-standby mode or that it needs to return to normal operation should it already have been in the hot-standby mode.

NOTE: The system controller needs to ensure that only one of the power supplies is allowed to enter the hot-standby model.

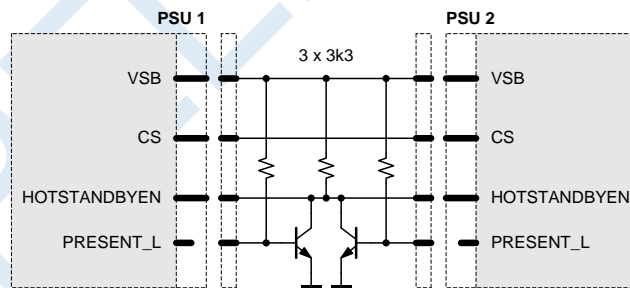

Figure 14. Recommended hot-standby configuration

In order to prevent voltage dips when the active power supply is unplugged while the other is in hot-standby mode, it is strongly recommended to add the external circuit as shown in 15. If the PRESENT_L pin status needs also to be read by the system controller, it is recommended to exchange the bipolar transistors with small signal MOS transistors or with digital transistors.

8.12 I2C / SMBUS COMMUNICATION

The interface driver in the PFS supply is referenced to the V1 Return. The PFS supply is a communication Slave device only; it never initiates messages on the I2C/SMBus by itself. The communication bus voltage and timing is defined in Table 7 further characterized through:

- There are no internal pull-up resistors
- The SDA/SCL IOs are 3.3/5 V tolerant
- Full SMBus clock speed of 100 kbps
- Clock stretching limited to 1 ms
- SCL low time-out of >25 ms with recovery within 10 ms
- Recognizes any time Start/Stop bus conditions

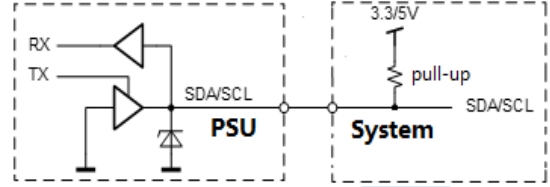

Figure 15. Physical layer of communication interface

The SMB_ALERT_L signal indicates that the power supply is experiencing a problem that the system agent should investigate. This is a logical OR of the Shutdown and Warning events. The power supply responds to a read command on the general SMB_ALERT_L call address 25(0x19) by sending its status register.

Communication to the DSP or the EEPROM will be possible as long as the input AC voltage is provided. If no AC is present, communication to the unit is possible as long as it is connected to a life V1 output (provided e.g. by the redundant unit). If only VSB is provided, communication is not possible.

PARAMETER	DESCRIPTION / CONDITION	MIN	NOM	MAX	UNIT
V_{IL}	Input low voltage	-0.5		1.0	V
V_{IH}	Input high voltage	2.3		5.5	V
V_{hys}	Input hysteresis	0.15			V
V_{oL}	Output low voltage	3 mA sink current	0	0.4	V
t_r	Rise time for SDA and SCL ($V_{iLmax}-0.15V$ to $V_{iHmin}+0.15V$)	0.65V to 2.25V $f_{SCL} \leq 100$ kHz	$20+0.1Cb^3$	1000	ns
t_{of}	Output fall time ($V_{iHmin}+0.15V$ to $V_{iLmax}-0.15V$)	2.25V to 0.65V $f_{SCL} \leq 100$ kHz	$20+0.1Cb^3$	300	ns
I_i	Input current SCL/SDA	$0.1 VDD < V_i < 0.9 VDD$	-10	10	μA
C_i	Internal Capacitance for each SCL/SDA			50	pF
f_{SCL}	SCL clock frequency		0	100	kHz
R_{pu}	External pull-up resistor	$f_{SCL} \leq 100$ kHz		1000 ns / Cb	Ω
t_{HDSTA}	Hold time (repeated) START	$f_{SCL} \leq 100$ kHz	4.0		μs
t_{LOW}	Low period of the SCL clock	$f_{SCL} \leq 100$ kHz	4.7		μs
t_{HIGH}	High period of the SCL clock	$f_{SCL} \leq 100$ kHz	4.0		μs
t_{SUSTA}	Setup time for a repeated START	$f_{SCL} \leq 100$ kHz	4.7		μs
t_{HDDAT}	Data hold time	$f_{SCL} \leq 100$ kHz	0	3.45	μs
t_{SUDAT}	Data setup time	$f_{SCL} \leq 100$ kHz	250		ns
t_{SUSTO}	Setup time for STOP condition	$f_{SCL} \leq 100$ kHz	4.0		μs
t_{BUF}	Bus free time between STOP and START	$f_{SCL} \leq 100$ kHz	5		ms

Table 7. I2C / SMBus Specification

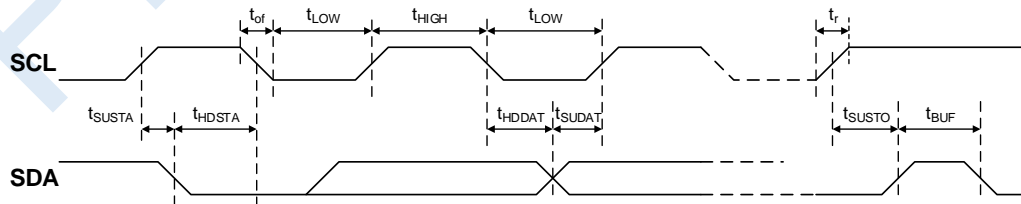

Figure 16. I2C / SMBus Timing

3 Cb = Capacitance of bus line in pF, typically in the range of 10...400 pF

8.13 ADDRESS / PROTOCOL SELECTION (APS)

The APS pin provides the possibility to select the address by connecting a resistor to V1 return (0 V). A fixed addressing offset exists between the Controller and the EEPROM.

NOTES:

- If the APS pin is left open, the supply will operate with the Power Management Bus protocol at controller / EEPROM addresses 0xB6 / 0xA6.
- The APS pin is only read at start-up of the power supply. Therefore, it is not possible to change address dynamically.

R _{APS} (Ω) ⁴	Protocol	I2C Address ⁵	
		Controller	EEPROM
820	Power Management Bus	0xB0	0xA0
2700		0xB2	0xA2
5600		0xB4	0xA4
8200		0xB6	0xA6
15000	PSMI	0xB0	0xA0
27000		0xB2	0xA2
56000		0xB4	0xA4
180000		0xB6	0xA6

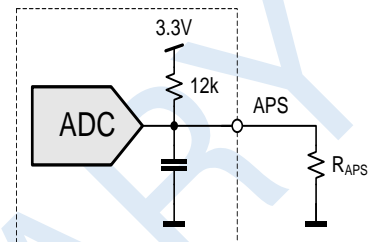

Figure 17. I2C address and protocol setting

8.14 CONTROLLER AND EEPROM ACCESS

The controller and the EEPROM in the power supply share the same I2C bus physical layer, see Figure 16. An I2C driver device assures logic level shifting (3.3/5 V) and a glitch-free clock stretching. The driver also pulls the SDA/SCL line to nearly 0 V when driven low by the DSP or the EEPROM providing maximum flexibility when additional external bus repeaters are needed. Such repeaters usually encode the low state with different voltage levels depending on the transmission direction.

The DSP will automatically set the I2C address of the EEPROM with the necessary offset when its own address is changed / set. In order to write to the EEPROM, first the write protection needs to be disabled by sending the appropriate command to the DSP. By default, the write protection is on.

The EEPROM provides 256 bytes of user memory. None of the bytes are used for the operation of the power supply.

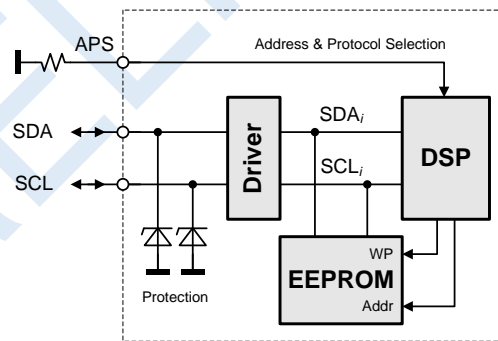

Figure 18. I2C Bus to DPS and EEPROM

⁴ E12 resistor values, use max 5% resistors, see also Figure 14
⁵ The LSB of the address byte is the R/W bit

8.15 EEPROM PROTOCOL

The EEPROM follows the industry communication protocols used for this type of device. Even though page write / read commands are defined, it is recommended to use the single byte write / read commands.

WRITE

The write command follows the SMBus 1.1 Write Byte protocol. After the device address with the write bit cleared a first byte with the data address to write to is sent followed by the data byte and the STOP condition. A new START condition on the bus should only occur after 5ms of the last STOP condition to allow the EEPROM to write the data into its memory.



READ

The read command follows the SMBus 1.1 Read Byte protocol. After the device address with the write bit cleared the data address byte is sent followed by a repeated start, the device address and the read bit set. The EEPROM will respond with the data byte at the specified location.

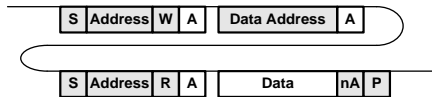

8.16 POWER MANAGEMENT BUS PROTOCOL

The Power Management Bus is an open standard protocol that defines means of communicating with power conversion and other devices. For more information, please see the System Management Interface Forum web site at www.powerSIG.org.

Power Management Bus command codes are not register addresses. They describe a specific command to be executed. The PFS1200-12-054NAH supply supports the following basic command structures:

- Clock stretching limited to 1 ms
- SCL low time-out of >25 ms with recovery within 10 ms
- Recognized any time Start/Stop bus conditions

WRITE

The write protocol is the SMBus 1.1 Write Byte/Word protocol. Note that the write protocol may end after the command byte or after the first data byte (Byte command) or then after sending 2 data bytes (Word command).

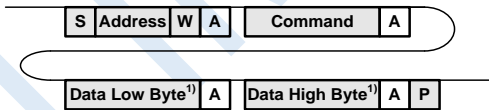

¹⁾ Optional

In addition, Block write commands are supported with a total maximum length of 255 bytes. See PFS Programming Manual for further information.

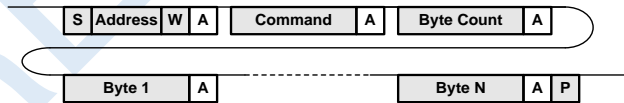

READ

The read protocol is the SMBus 1.1 Read Byte/Word protocol. Note that the read protocol may request a single byte or word.

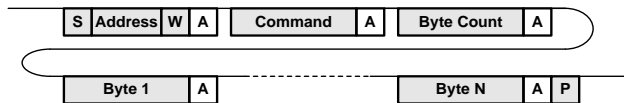

In addition, Block read commands are supported with a total maximum length of 255 bytes. See PFS Programming Manual BCA.00006 for further information.

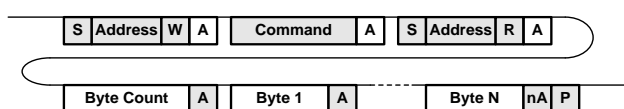

8.17 PSMI PROTOCOL

New power management features in computer systems require the system to communicate with the power supply to access current, voltage, fan speed, and temperature information. Current measurements provide data to the system for determining potential system configuration limitations and provide actual system power consumption for facility planning. Temperature and fan monitoring allow the system to better manage fan speeds and temperatures for optimizing system acoustics. Voltage monitoring allows the system to calculate input wattage and warning of system voltage regulation problems. The Power Supply Management Interface (PSMI) supports diagnostic capabilities and allows managing of redundant power supplies. The communication method is SMBus. The current design guideline is version 2.12.

The communication protocol is register based and defines a read and write communication protocol to read / write to a single register address. All registers are accessed via the same basic command given below. No PEC (Packet Error Code) is used.

WRITE

The write protocol used is the SMBus 2.0 Write Word protocol. All writes are 16-bit words; byte reads are not supported nor allowed. The shaded areas in the figure indicate bits and bytes written by the PSMI master device. See PFS Programming Manual for further information.

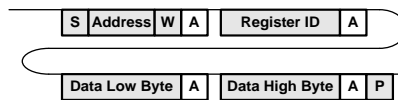

READ

The read protocol used is the SMBus 2.0 Read Word protocol. All reads are 16-bit words; byte reads are not supported nor allowed. The shaded areas in the figure indicate bits and bytes written by the PSMI master device. See PFS Programming Manual for further information.

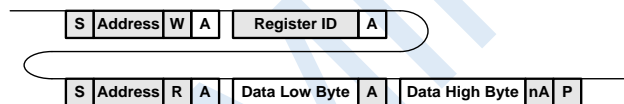

8.18 GRAPHICAL USER INTERFACE

Bel Power Solutions provides with its “Bel Power Solutions I2C Utility” a Windows® XP/Vista/Win7 compatible graphical user interface allowing the programming and monitoring of the PFS1200-12-054NAH Front-End. The utility can be downloaded on: belfuse.com/power-solutions and supports Power Management Bus protocols.

The GUI allows automatic discovery of the units connected to the communication bus and will show them in the navigation tree. In the monitoring view the power supply can be controlled and monitored.

If the GUI is used in conjunction with the SNP-OP-BOARD-01 or YTM.G1Q01.0 Evaluation Kit it is also possible to control the PSON_L pin(s) of the power supply.

Further there is a button to disable the internal fan for approximately 10 seconds. This allows the user to take input power measurements without fan consumptions to check efficiency compliance to the Climate Saver Computing Platinum specification.

The monitoring screen also allows to enable the hot-standby mode on the power supply. The mode status is monitored and by changing the load current it can be monitored when the power supply is being disabled for further energy savings. This obviously requires 2 power supplies being operated as a redundant system (as in the evaluation kit).

NOTE: The user of the GUI needs to ensure that only one of the power supplies have the hot-standby mode enabled.



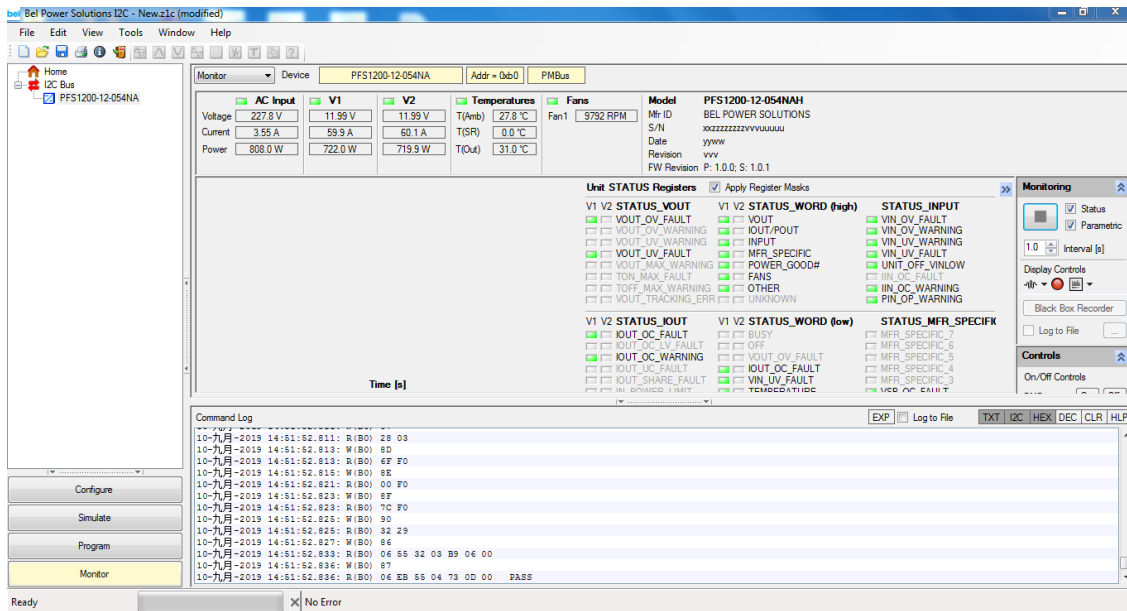

Figure 19. Monitoring dialog of the I2C Utility

9. TEMPERATURE AND FAN CONTROL

To achieve best cooling results sufficient airflow through the supply must be ensured. Do not block or obstruct the airflow at the rear of the supply by placing large objects directly at the output connector. The PFS1200-12-054NAH is provided with normal airflow, which means the air enters through the DC-output of the supply and leaves at the AC-inlet. PFS supplies have been designed for horizontal operation.

The fan inside of the supply is controlled by a microprocessor. The RPM of the fan is adjusted to ensure optimal supply cooling and is a function of output power and the inlet temperature.

For the normal airflow version additional constraints apply because of the AC-connector. In a normal airflow unit, the hot air is exiting the power supply unit at the AC-inlet.

The IEC connector on the unit is rated 105°C. If 70°C mating connector is used then end user must derated the input power to meet a maximum 70°C temperature at the front.

NOTE: It is the responsibility of the user to check the front temperature in such cases. The unit is not limiting its power automatically to meet such a temperature limitation.



Figure 20. Airflow direction

10. ELECTROMAGNETIC COMPATIBILITY

10.1 IMMUNITY

NOTE: Most of the immunity requirements are derived from EN 55024:1998/A2:2003.

PARAMETER	DESCRIPTION / CONDITION	CRITERION
ESD Contact Discharge	IEC / EN 61000-4-2, ± 8 kV, 25+25 discharges per test point (metallic case, LEDs, connector body)	A
ESD Air Discharge	IEC / EN 61000-4-2, ± 15 kV, 25+25 discharges per test point (non-metallic user accessible surfaces)	A
Radiated Electromagnetic Field	IEC / EN 61000-4-3, 10 V/m, 1 kHz/80% Amplitude Modulation, 1 μ s Pulse Modulation, 10 kHz...2 GHz	A
Burst	IEC / EN 61000-4-4, level 3 AC port ± 2 kV, 1 minute DC port ± 1 kV, 1 minute	A
Surge	IEC / EN 61000-4-5 Line to earth: level 3, ± 2 kV Line to line: level 2, ± 1 kV	A
RF Conducted Immunity	IEC/EN 61000-4-6, Level 3, 10 Vrms, CW, 0.1 ... 80 MHz	A
Voltage Dips and Interruptions	IEC/EN 61000-4-11 1: V_i 230 V, 100% Load, Phase 0°, Dip 100%, Duration 10 ms 2: V_i 230 V, 100% Load, Phase 0°, Dip 100%, Duration 20 ms 3: V_i 230 V, 100% Load, Phase 0°, Dip 100%, Duration >20 ms	A V _{SB} : A, V _I : B B

10.2 EMISSION

PARAMETER	DESCRIPTION / CONDITION	CRITERION
Conducted Emission	EN55022 / CISPR 22: 0.15 ... 30 MHz, QP and AVG, single unit	Class A
	EN55022 / CISPR 22: 0.15 ... 30 MHz, QP and AVG, 2 units in rack system	Class A
Radiated Emission	EN55022 / CISPR 22: 30 MHz ... 1 GHz, QP, single unit	Class A
	EN55022 / CISPR 22: 30 MHz ... 1 GHz, QP, 2 units in rack system	Class A
Harmonic Emissions	IEC61000-3-2, $V_{in} = 115$ VAC / 60 Hz, & $V_{in} = 230$ VAC/ 50 Hz, 100% Load	Class A
AC Flicker	IEC61000-3-3, $V_{in} = 230$ VAC / 60 Hz, 100% Load	Pass

11. SAFETY APPROVALS

Maximum electric strength testing is performed in the factory according to IEC/EN 60950, and UL 60950. Input-to-output electric strength tests should not be repeated in the field. Bel Power Solutions will not honor any warranty claims resulting from electric strength field tests.

PARAMETER	DESCRIPTION / CONDITION	MIN	NOM	MAX	UNIT
Agency Approvals	UL 60950-1 Second Edition CAN/CSA-C22.2 No. 60950-1-07 Second Edition IEC 60950-1:2005 EN 60950-1:2006		Approved by independent body (see CE Declaration)		
Isolation Strength	Input (L/N) to case (PE)		Basic		
	Input (L/N) to output		Reinforced		
	Output to case (PE)		Functional		
α Creepage / Clearance	Primary (L/N) to protective earth (PE) Primary to secondary		According to safety standard		mm
Electrical Strength Test	Input to case		According to safety standard		kVAC
	Input to output				
	Output and Signals to case				



Asia-Pacific
+86 755 298 85888

Europe, Middle East
+353 61 225 977

North America
+1 408 785 5200

12. ENVIRONMENTAL SPECIFICATIONS

PARAMETER	DESCRIPTION / CONDITION	MIN	NOM	MAX	UNIT		
T_A	Ambient Temperature	V_{min} to V_{max} , I_{nom} , $S_{B nom}$ below 1800m Altitude (< 1800m, keep maximum operation temperature. $\geq 1800m$, decrease 1° C per 300m)			-5	+50	°C
T_{Aext}	Extended Temp. Range	Derating output			+50	+70	°C
T_S	Storage Temperature	Non-operational			-40	+70	°C
	Altitude	Operational, above Sea Level, refer derating to T_A			-	3000	m
N_A	Audible Noise	V_{nom} , 50% I_{nom} , $T_A = 25^\circ C$				60	dBA

13. MECHANICAL SPECIFICATIONS

PARAMETER	DESCRIPTION / CONDITION	MIN	NOM	MAX	UNIT	
	Dimensions	Width			54.5	
		Height			40.0	mm
		Depth			228.6	
M	Weight				0.87	kg

PFS1200-12-054NAH

Input AC connector Anderson 2006G1-BK

NOTE: A 3D step file of the power supply casing is available on request.

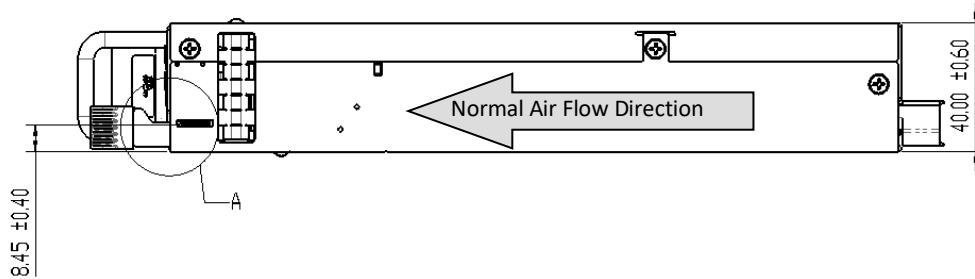

Figure 18. Side View

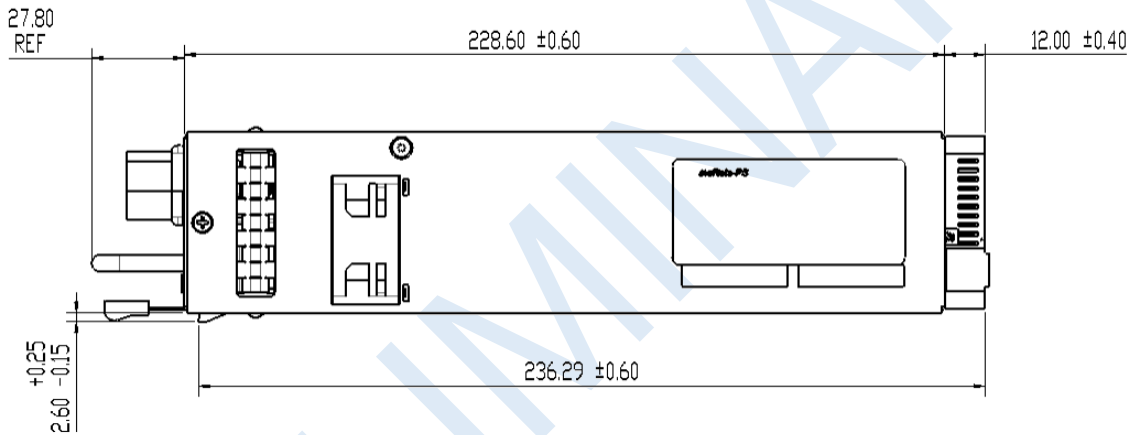

Figure 21. Top View

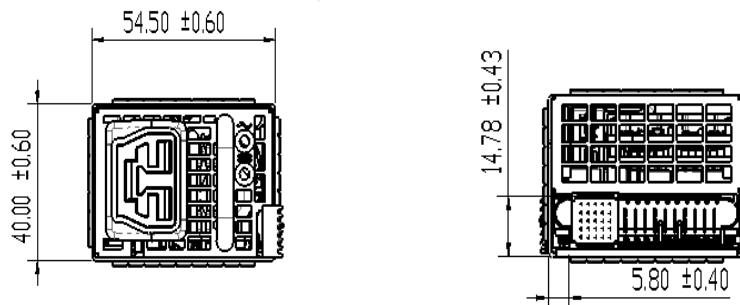

Figure 22. Front and Rear View

14. CONNECTIONS

AC INPUT CONNECTOR:

PFS1200-12-054NAH: Power supplier connector: Anderson P/N 2006G1-BK

Mating connector:

BizLink, type: BC-326, <http://www.bizlinktech.com/>

LongWell, type: LS-26, <http://www.longwell.com/cn/>

LINETEK, type: LS-24, http://w3.linetek.com.tw/html/F2_E.htm

DC OUTPUT CONNECTOR:

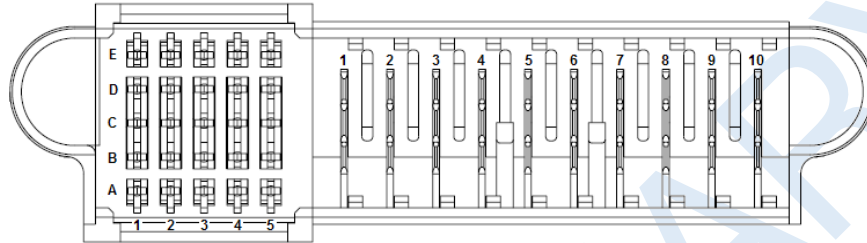



Power Supply Connector: Tyco Electronics P/N 2-1926736-3 (NOTE: Column 5 is recessed (short pins))

Mating Connector: Tyco Electronics P/N 2-1926739-5 or FCI 10108888-R10253SLF

PIN	NAME	DESCRIPTION
Output		
6, 7, 8, 9, 10	V1	+12 VDC main output
1, 2, 3, 4, 5	PGND	Power ground (return)
Control Pins		
A1	VSB	Standby positive output
B1	VSB	Standby positive output
C1	VSB	Standby positive output
D1	VSB	Standby positive output
E1	VSB	Standby positive output
A2	SGND	Signal ground (VSB Return)
B2	SGND	Signal ground (VSB Return)
C2	HOTSTANDBYEN_H	Hot standby enable signal: active-high
D2	N/C	Reserved
E2	N/C	Reserved
A3	APS	I ² C address and protocol selection (select by a pull down resistor)
B3	N/C	Reserved
C3	SDA	I ² C data signal line
D3	V1_SENSE_R	Main output negative sense
E3	V1_SENSE	Main output positive sense
A4	SCL	I ² C clock signal line
B4	PSON_L	Power supply on input (connect to A2/B2 to turn unit on): active-low
C4	SMB_ALERT_L	SMB Alert signal output: active-low
D4	N/C	Reserved
E4	ACOK_H	AC input OK signal: active-high
A5	PSKILL_H	Power supply kill (lagging pin): active-high
B5	ISHARE	Current share bus (lagging pin)
C5	PWOK_H	Power OK signal output (lagging pin): active-high
D5	N/C	Reserved
E5	PRESENT_L	Power supply present (lagging pin): active-low

15. ACCESSORIES

ITEM	DESCRIPTION	ORDERING PART NUMBER	SOURCE
	<p>Bel Power Solutions I²C Utility</p> <p>Windows XP/Vista/7 compatible GUI to program, control and monitor PFS Front-Ends (and other I²C units)</p>	N/A	belfuse.com/power-solutions
	<p>Dual Connector Board</p> <p>Connector board to operate 2 PFS units in parallel. Includes an on-board USB to I²C converter (use <i>Bel Power Solutions I²C Utility</i> as desktop software).</p>	SNP-OP-BOARD-01 or YTM.G1Q01.0	belfuse.com/power-solutions

16. REVISION HISTORY

DATE	REVISION	CHANGE	PREPARED BY	APPROVED BY	ECO / MCO REF. NO.
2019/10/21	1	Initial release	Mike Chen	Mike Chen	C92902
2019/10/21	2	General update throughout the whole datasheet	Steven Ling	Mike Chen	C96518

For more information on these products consult: tech.support@psbel.com

NUCLEAR AND MEDICAL APPLICATIONS - Products are not designed or intended for use as critical components in life support systems, equipment used in hazardous environments, or nuclear control systems.

TECHNICAL REVISIONS - The appearance of products, including safety agency certifications pictured on labels, may change depending on the date manufactured. Specifications are subject to change without notice.



Asia-Pacific
+86 755 298 85888

Europe, Middle East
+353 61 225 977

North America
+1 408 785 5200