



Shielded Power Inductors – PFL1005



Continuing in our long tradition of innovation and leadership, Coilcraft introduces the industry's first true 0402 size shielded power inductor.

Core material Composite

Weight 1.3 – 1.8 mg

Environmental RoHS compliant, halogen free

Terminations RoHS compliant matte tin over nickel over silver-palladium-glass frit.

Ambient temperature –40°C to +85°C with Irms current, +85°C to +125°C with derated current

Storage temperature Component: –40°C to +125°C.

Tape and reel packaging: –40°C to +80°C

Resistance to soldering heat Max three 40 second reflows at +260°C, parts cooled to room temperature between cycles

Moisture Sensitivity Level (MSL) 1 (unlimited floor life at <30°C / 85% relative humidity)

Failures in Time (FIT) / Mean Time Between Failures (MTBF)

38 per billion hours / 26,315,789 hours, calculated per Telcordia SR-332

Packaging 2000 per 7" reel Paper tape: 8 mm wide, 0.68 mm thick, 2 mm pocket spacing

PCB washing Tested with pure water or alcohol only. For other solvents, see Doc787_PCB_Washing.pdf

Part number ¹	Inductance ² ±20% (nH)	DCR (Ohms) ³		SRF typ ⁴ (MHz)	Isat (mA) ⁵			Irms (mA) ⁶	
		typ	max		10% drop	20% drop	30% drop	20°C rise	40°C rise
PFL1005-36NMR_	36	0.034	0.043	2500	1500	2400	2800	1400	2000
PFL1005-60NMR_	60	0.042	0.050	2100	1300	1900	2100	1200	1600
PFL1005-101MR_	100	0.059	0.075	2200	1000	1500	1900	1100	1500
PFL1005-181MR_	180	0.19	0.21	1250	700	880	1100	900	1200
PFL1005-271MR_	270	0.22	0.24	920	450	650	740	700	910
PFL1005-391MR_	390	0.45	0.51	770	380	510	550	450	570
PFL1005-561MR_	560	0.48	0.54	620	300	440	490	410	530
PFL1005-721MR_	720	0.62	0.68	560	280	400	450	370	470
PFL1005-102MR_	1000	0.97	1.08	460	270	350	380	310	400

1. When ordering, please specify **packaging** codes:

↓
PFL1005-102MRW

Packaging: **W** = 7" machine-ready reel. EIA-481 punched paper tape (2000 parts per full reel).

U = Less than full reel. In tape, but not machine ready. To have a leader and trailer added (\$25 charge), use code letter W instead.

2. Inductance tested at 7.9 MHz, 0.1 Vrms using a Coilcraft SMD-F test fixture and Coilcraft-provided correlation pieces with an Agilent/HP 4286 impedance analyzer.

3. DCR measured on a micro-ohmmeter.

4. SRF measured using an Agilent/HP 8753D network analyzer and a Coilcraft SMD-D test fixture.

5. DC current that causes the specified inductance drop from its value without current.

6. Current that causes the specified temperature rise from 25°C ambient.

7. Electrical specifications at 25°C.

Refer to Doc 362 "Soldering Surface Mount Components" before soldering.

COILCRAFT ACCURATE
PRECISION REPEATABLE
MEASUREMENTS
SEE WEB SITE **TEST FIXTURES**



www.coilcraft.com

US +1-847-639-6400 sales@coilcraft.com

UK +44-1236-730595 sales@coilcraft-europe.com

Taiwan +886-2-2264 3646 sales@coilcraft.com.tw

China +86-21-6218 8074 sales@coilcraft.com.cn

Singapore + 65-6484 8412 sales@coilcraft.com.sg

Document 739-1 Revised 04/03/13

© Coilcraft Inc. 2013

This product may not be used in medical or high risk applications without prior Coilcraft approval. Specification subject to change without notice. Please check web site for latest information.



PFL1005 Series (0402)

Typical L vs Current

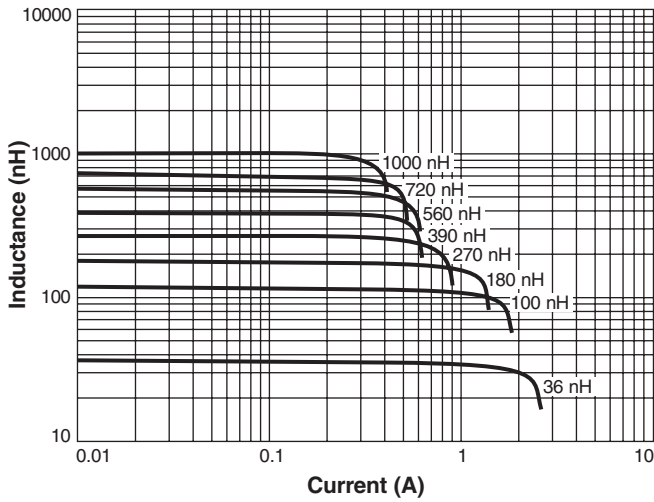

Typical L vs Frequency

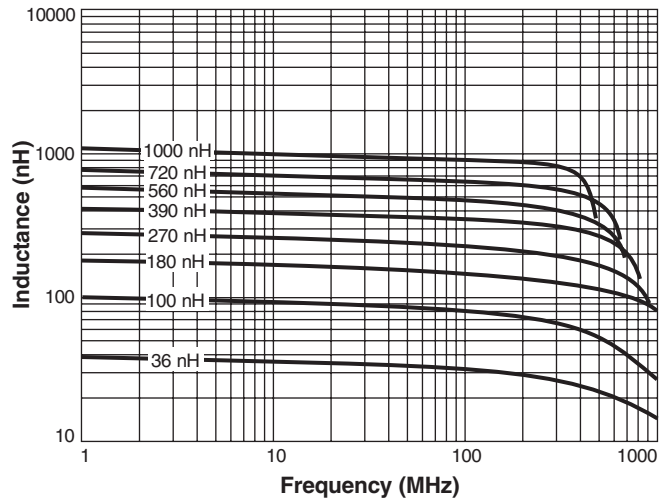

Irms Derating

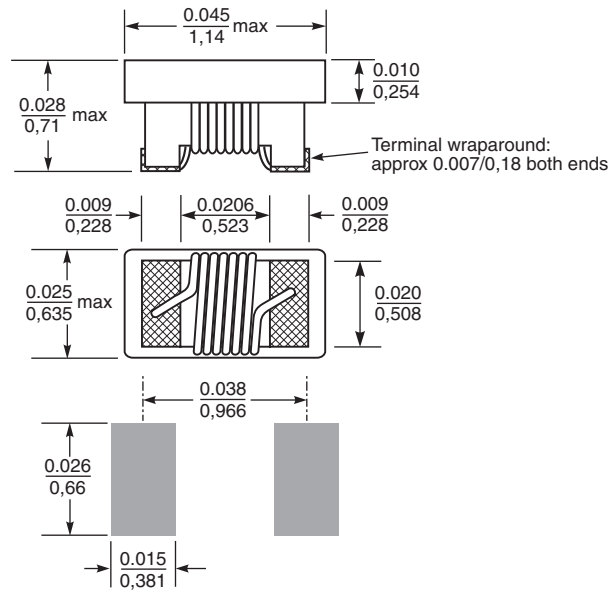
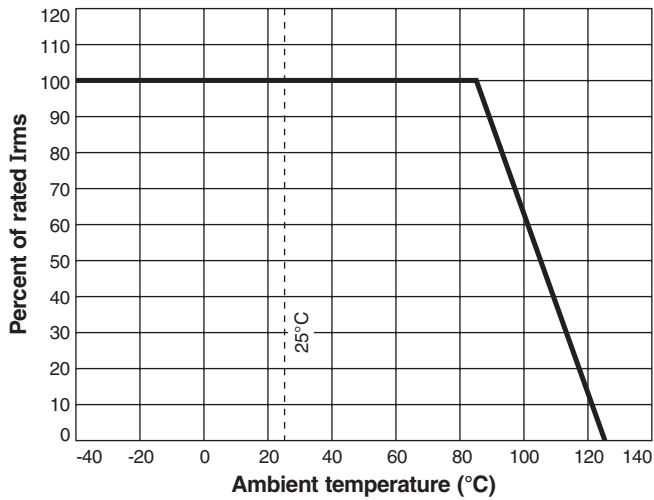

Recommended Land Pattern

Dimensions are in $\frac{\text{inches}}{\text{mm}}$