

UltraCMOS[®] Digitally Tunable Capacitor (DTC)
100 - 3000 MHz

Features

- 3-wire (SPI compatible) serial interface with built-in bias voltage generation and ESD protection
- DuNE™ technology enhanced
- 5-bit 32-state digitally tunable capacitor
- Shunt configuration $C = 0.9 \text{ pF}$ to 4.6 pF (5.1:1 tuning ratio) in discrete 119 fF steps
- High RF power handling (30 V_{pk} RF) and linearity
- Wide power supply range (2.3V to 4.8V) and low current consumption (typ. $140 \mu\text{A}$ at 2.75V)
- High ESD tolerance of 2 kV HBM on all pins
- Applications include:
 - Tunable antennas
 - Tunable matching networks
 - Tunable filter networks

Product Description

PE64906 is a DuNE™ technology-enhanced digitally tunable capacitor (DTC) based on pSemi's UltraCMOS[®] technology. This highly versatile product supports a wide variety of tuning circuit topologies with emphasis on impedance matching and aperture tuning applications.

PE64906 offers high RF power handling and ruggedness while meeting challenging harmonic and linearity requirements enabled by pSemi's HaRP™ technology. The device is controlled through the widely supported 3-wire (SPI compatible) interface. All decoding and biasing is integrated on-chip and no external bypassing or filtering components are required.

DuNE devices feature ease of use while delivering superior RF performance in the form of tuning accuracy, monotonicity, tuning ratio, power handling, size, and quality factor. With built-in bias voltage generation and ESD protection, DTC products provide a monolithically integrated tuning solution for demanding RF applications.

Figure 1. Functional Diagram

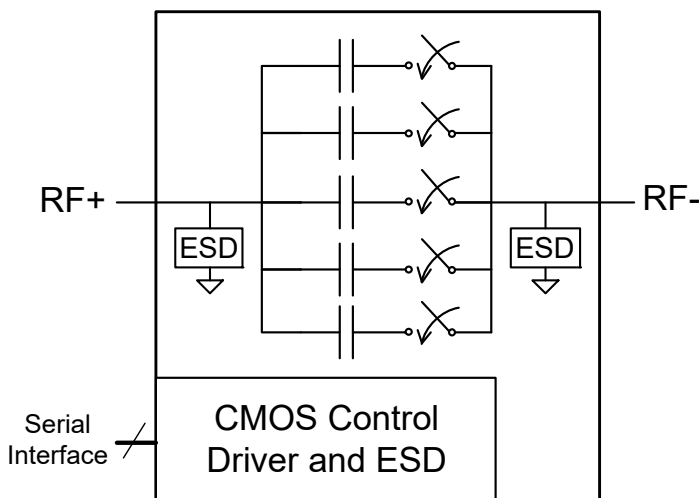

DOC-02169

Figure 2. Package Type

10-lead 2 x 2 x 0.55 mm QFN

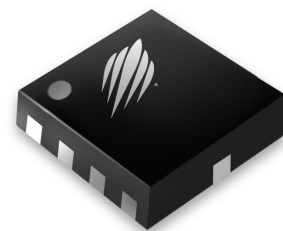

Table 1. Electrical Specifications @ 25 °C, V_{DD} = 2.75V (In shunt configuration, RF- connected to GND)

Parameter	Condition	Min	Typ	Max	Unit
Operating frequency		100		3000	MHz
Minimum capacitance (C _{min})	State = 00000, 100 MHz	0.81	0.9	0.99	pF
Maximum capacitance (C _{max})	State = 11111, 100 MHz	3.68	4.6	5.52	pF
Tuning ratio	C _{max} /C _{min} , 100 MHz		5.1:1		
Step size	5 bits (32 states), 100 MHz		0.119		pF
Quality factor at C _{min} ¹	698–960 MHz, with L _S removed 1710–2170 MHz, with L _S removed		40 40		
Quality factor at C _{max} ¹	698–960 MHz, with L _S removed 1710–2170 MHz, with L _S removed		29 13		
Self resonant frequency	State 00000 State 11111		7.9 2.8		GHz
Harmonics ²	2fo, 3fo: 698–915 MHz; P _{IN} = +34 dBm, 50Ω 2fo, 3fo: 1710–1910 MHz; P _{IN} = +32 dBm, 50Ω			-36 -36	dBm dBm
IMD3	Bands I,II,V/VIII, +20 dBm CW @ TX freq, -15 dBm CW @ 2TX-RX freq, 50Ω			-105	dBm
Third order intercept point (IP3)	Shunt configuration derived from IMD3 spec IP3 = (2P _{TX} + P _{block} - IMD3) / 2		65		dBm
Switching time ^{3,4}	State change to 10/90% delta capacitance between any two states			12	μs
Start-up time ³	Time from V _{DD} within specification to all performances within specification			70	μs
Wake-up time ^{3,4}	State change from Standby mode to RF state to all performances within specification			70	μs

- Notes: 1. Q for a shunt DTC based on a series RLC equivalent circuit
 $Q = X_C / R = (X - X_L) / R$, where $X = X_L + X_C$, $X_L = 2\pi f L$, $X_C = -1 / (2\pi f C)$, which is equal to removing the effect of parasitic inductance L_S
 2. In shunt between 50Ω ports. Pulsed RF input with 4620 μS period, 50% duty cycle, measured per 3GPP TS 45.005
 3. DC path to ground at RF- must be provided to achieve specified performance

Figure 3. Pin Configuration (Top View)

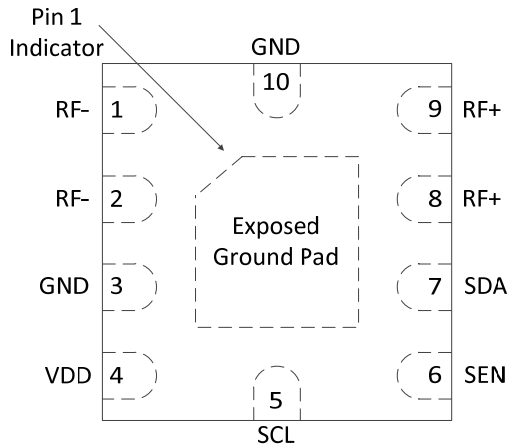

Table 2. Pin Descriptions

Pin #	Pin Name	Description
1	RF-	Negative RF port ¹
2	RF-	Negative RF port ¹
3	GND	Ground ²
4	V _{DD}	Power supply pin
5	SCL	Serial interface clock input
6	SEN	Serial interface latch enable input
7	SDA	Serial interface data input
8	RF+	Positive RF port ¹
9	RF+	Positive RF port ¹
10	GND	Ground ²
Pad	GND	Exposed pad: ground for proper operation ²

Notes: 1. For optimal performance, recommend tying Pins 1-2 and Pins 8-9 together on PCB
2. For optimal performance, recommend tying Pins 3, 10 and exposed ground pad together on PCB

Moisture Sensitivity Level

The Moisture Sensitivity Level rating for the PE64906 in the 10-lead 2 x 2 x 0.55 mm QFN package is MSL1.

Table 3. Operating Ranges

Parameter	Symbol	Min	Typ	Max	Unit
Supply voltage	V _{DD}	2.30	2.75	4.80	V
Supply current (V _{DD} = 2.75V)	I _{DD}		140	200	μA
Standby current (V _{DD} = 2.75V)	I _{DD}		25		μA
Digital input high	V _{IH}	1.2	1.8	3.1	V
Digital input low	V _{IL}	0	0	0.57	V
RF input power (50Ω) ¹ 698–915 MHz 1710–1910 MHz				+34 +32	 dBm dBm
Peak operating RF voltage ² V _P to V _M V _P to RFGND				30 30	 V _{pk} V _{pk}
Operating temperature range	T _{OP}	-40	+25	+85	°C
Storage temperature range	T _{ST}	-65	+25	+150	°C

Notes: 1. Maximum power available from 50Ω source. Pulsed RF input with 4620 μs period, 50% duty cycle, measured per 3GPP TS 45.005 measured in shunt between 50Ω ports, RF- connected to GND
2. Node voltages defined per Equivalent Circuit Model Schematic (Figure 13). When DTC is used as a part of reactive network, impedance transformation may cause the internal RF voltages (V_P, V_M) to exceed peak operating RF voltage even with specified RF input power levels. For operation above about +20 dBm (100 mW), the complete RF circuit must be simulated using actual input power and load conditions, and internal node voltages (V_P, V_M in Figure 13) monitored to not exceed 30 V_{pk}

Table 4. Absolute Maximum Ratings

Parameter/Condition	Symbol	Min	Max	Unit
ESD Voltage HBM*	V _{ESD}		2000	V

Note: * Human Body Model (MIL-STD-883 Method 3015.7)

Exceeding absolute maximum ratings may cause permanent damage. Operation should be restricted to the limits in the Operating Ranges table. Operation between operating range maximum and absolute maximum for extended periods may

Electrostatic Discharge (ESD) Precautions

When handling this UltraCMOS device, observe the same precautions that you would use with other ESD-sensitive devices. Although this device contains circuitry to protect it from damage due to ESD, precautions should be taken to avoid exceeding the specified rating.

Latch-Up Avoidance

Unlike conventional CMOS devices, UltraCMOS® devices are immune to latch-up.

Performance Plots @ 25 °C and 2.75V, unless otherwise specified

Figure 4. Measured Shunt C (@ 100 MHz) vs State

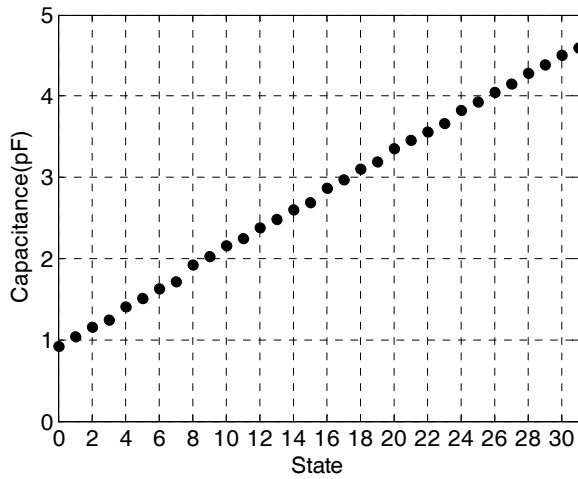

Figure 5. Measured Shunt S₁₁ (major states)

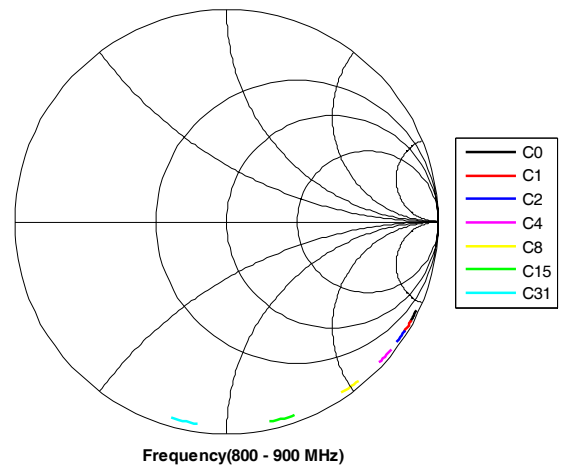

Figure 6. Measured Step Size vs State (frequency)

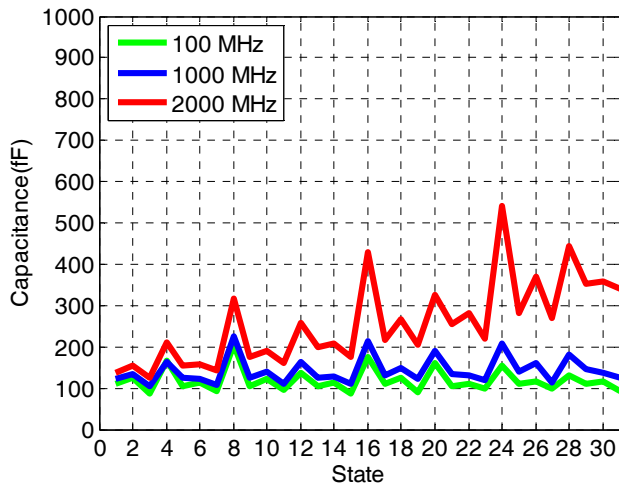

Figure 7. Measured Shunt C vs Frequency

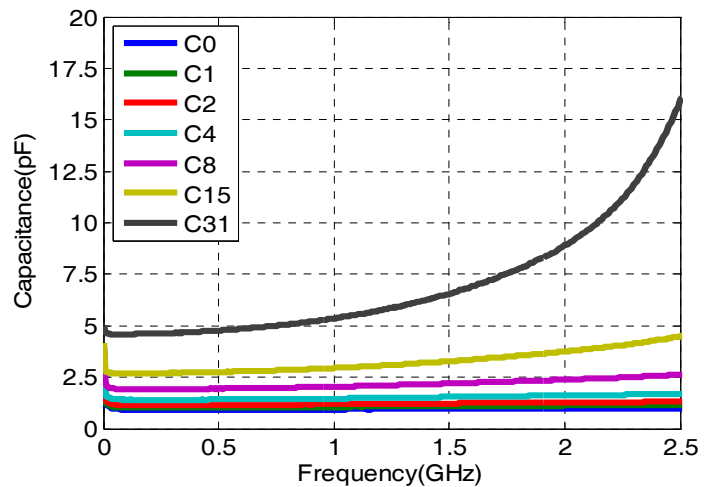

Figure 8. Measured Shunt Q vs Frequency (major states)

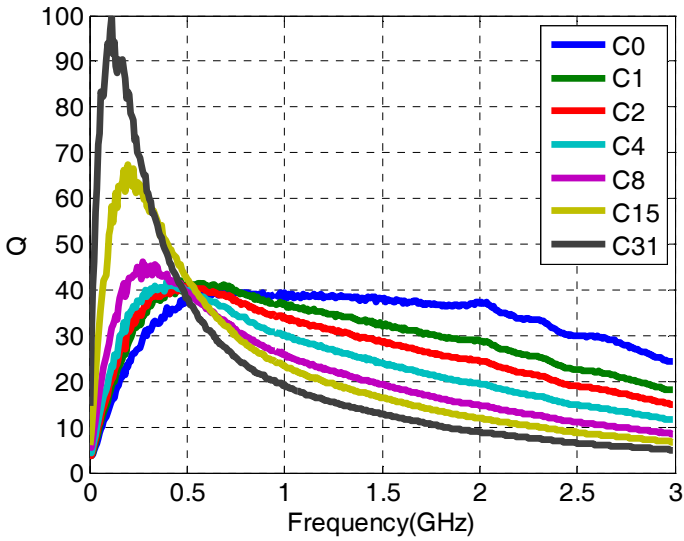

Figure 9. Measured Shunt Q vs State

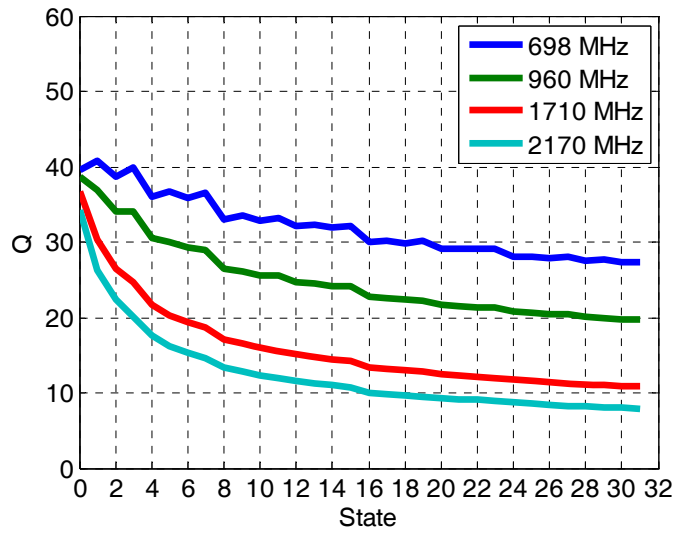
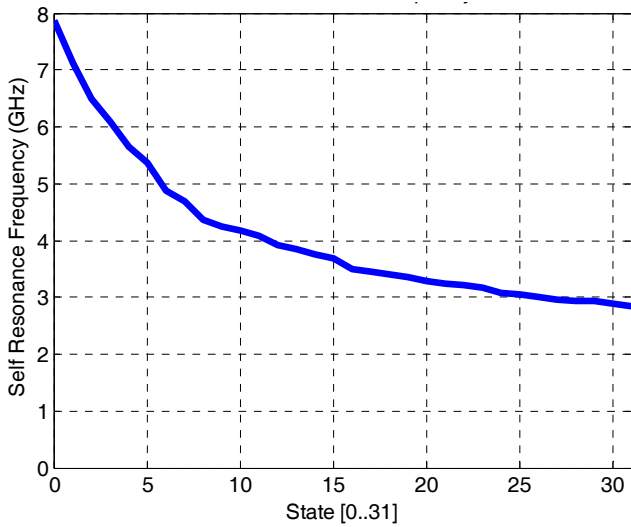

Figure 10. Measured Self Resonance Frequency



Serial Interface Operation and Sharing

The PE64906 is controlled by a three wire SPI-compatible interface. As shown in *Figure 11*, the serial master initiates the start of a telegram by driving the SEN (Serial Enable) line high. Each bit of the 8-bit telegram is clocked in on the rising edge of the SCL (Serial Clock) line. SDA bits are clocked by most significant bit (MSB) first, as shown in *Table 5* and *Figure 11*. Transactions on SDA (Serial Data) are allowed on the falling edge of SCL. The DTC activates the data on the falling edge of SEN. The DTC does not count how many bits are clocked and only maintains the last 8 bits it received.

More than 1 DTC can be controlled by one interface by utilizing a dedicated enable (SEN) line for each DTC. SDA, SCL, and V_{DD} lines may be shared as shown in *Figure 12*. Dedicated SEN lines act as a chip select such that each DTC will only respond to serial transactions intended for them. This makes each DTC change states sequentially as they are programmed.

Alternatively, a dedicated SDA line with common SEN can be used. This allows all DTCs to change states simultaneously, but requires all DTCs to be programmed even if the state is not changed.

Figure 11. Serial Interface Timing Diagram (oscilloscope view)

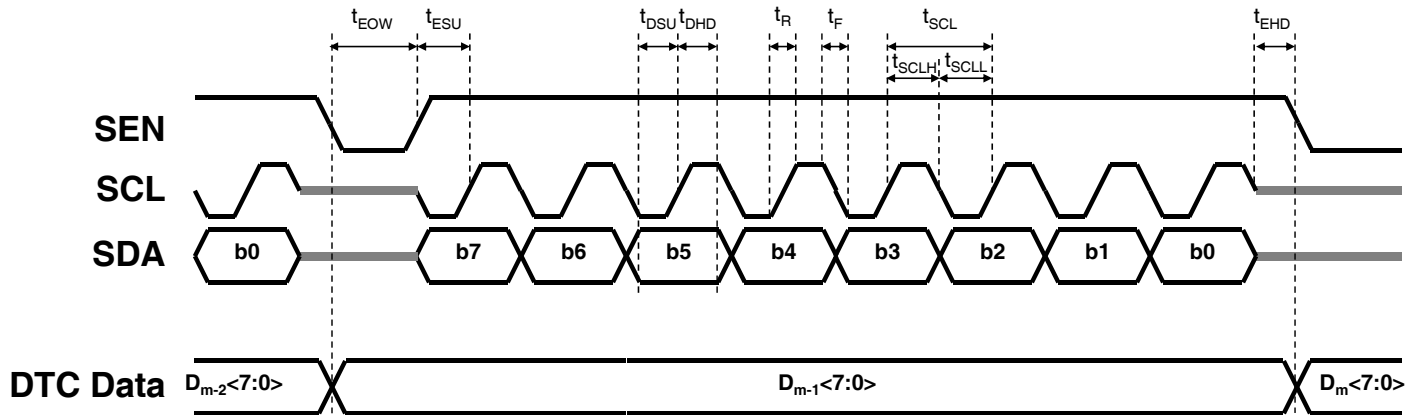

Table 5. Register Map

b7	b6	b5	b4	b3	b2	b1	b0
0 ¹	0 ¹	STB ²	d4	d3	d2	d1	d0

MSB (first in)

LSB (last in)

- Notes: 1. These bits are reserved and must be written to 0 for proper operation
2. The DTC is active when low (set to 0) and in low-current stand-by mode when high (set to 1)

Table 6. Serial Interface Timing Characteristics

V_{DD} = 2.75V, -40 °C < T_A < +85 °C, unless otherwise specified

Symbol	Parameter	Min	Max	Unit
t _{SCL}	Serial clock period	38.4		ns
t _{SCLL}	SCL low time	13.2		ns
t _{SCLH}	SCL high time	13.2		ns
t _R	SCL, SDA, SEN rise time		6.5	ns
t _F	SCL, SDA, SEN fall time		6.5	ns
t _{ESU}	SEN rising edge to SCL rising edge	19.2		ns
t _{EHD}	SCL rising edge to SEN falling edge	19.2		ns
t _{DSU}	SDA valid to SCL rising edge	13.2		ns
t _{DHD}	SDA valid after SCL rising edge	13.2		ns
t _{EOW}	SEN falling edge to SEN rising edge	38.4		ns

Figure 12. Recommended Bus sharing

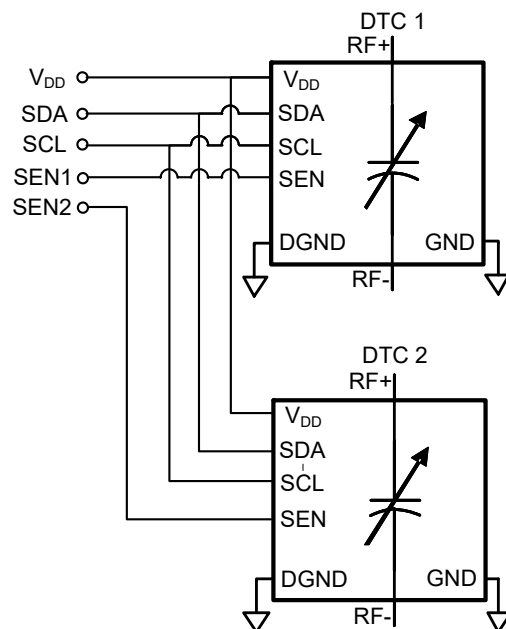

Equivalent Circuit Model Description

The DTC Equivalent Circuit Model includes all parasitic elements and is accurate in both series and shunt configurations, reflecting physical circuit behavior accurately and providing very close correlation to measured data. It can easily be used in circuit simulation programs.

For V_P and V_M max operating limits, refer to *Table 3*.

Figure 13. Equivalent Circuit Model Schematic

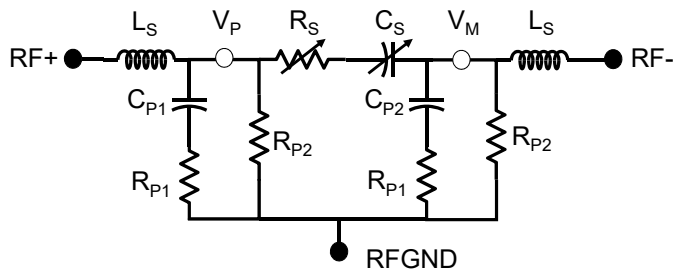

Table 7. Equivalent Circuit Model Parameters

Variable	Equation (state = 0, 1, 2...31)	Units
C_S	$0.127 \cdot \text{state} + 0.38$	pF
R_S	$20 / [\text{state} + 20 / (\text{state} + 0.7)] + 0.7$	Ω
R_{P1}	$8 + 3 \cdot \text{state}$	Ω
R_{P2}	$25000 + 3 \cdot \text{state}^3$	Ω
C_{P1}	$-0.0075 \cdot \text{state} + 0.52$	pF
C_{P2}	$0.0096 \cdot \text{state} + 0.61$	pF
L_S	0.35	nH

Table 8. Equivalent Circuit Data

State			DTC Core		Parasitic Elements			
Hex	Bin	Dec	C_S [pF]	R_S [Ω]	C_{P1} [pF]	C_{P2} [pF]	R_{P1} [Ω]	R_{P2} [k Ω]
0x00	00000	0	0.38	1.40	0.52	0.61	8.0	25.0
0x01	00001	1	0.51	2.27	0.51	0.62	11.0	25.0
0x02	00010	2	0.63	2.83	0.51	0.63	14.0	25.0
0x03	00011	3	0.76	3.08	0.50	0.64	17.0	25.1
0x04	00100	4	0.89	3.12	0.49	0.65	20.0	25.2
0x05	00101	5	1.02	3.05	0.48	0.66	23.0	25.4
0x06	00110	6	1.14	2.93	0.48	0.67	26.0	25.6
0x07	00111	7	1.27	2.78	0.47	0.68	29.0	26.0
0x08	01000	8	1.40	2.64	0.46	0.69	32.0	26.5
0x09	01001	9	1.52	2.51	0.45	0.70	35.0	27.2
0x0A	01010	10	1.65	2.39	0.45	0.71	38.0	28.0
0x0B	01011	11	1.78	2.27	0.44	0.72	41.0	29.0
0x0C	01100	12	1.90	2.17	0.43	0.73	44.0	30.2
0x0D	01101	13	2.03	2.08	0.42	0.73	47.0	31.6
0x0E	01110	14	2.16	2.00	0.42	0.74	50.0	33.2
0x0F	01111	15	2.29	1.93	0.41	0.75	53.0	35.1
0x10	10000	16	2.41	1.86	0.40	0.76	56.0	37.3
0x11	10001	17	2.54	1.80	0.39	0.77	59.0	39.7
0x12	10010	18	2.67	1.75	0.39	0.78	62.0	42.5
0x13	10011	19	2.79	1.70	0.38	0.79	65.0	45.6
0x14	10100	20	2.92	1.65	0.37	0.80	68.0	49.0
0x15	10101	21	3.05	1.61	0.36	0.81	71.0	52.8
0x16	10110	22	3.17	1.57	0.36	0.82	74.0	56.9
0x17	10111	23	3.30	1.54	0.35	0.83	77.0	61.5
0x18	11000	24	3.43	1.51	0.34	0.84	80.0	66.5
0x19	11001	25	3.56	1.48	0.33	0.85	83.0	71.9
0x1A	11010	26	3.68	1.45	0.33	0.86	86.0	77.7
0x1B	11011	27	3.81	1.42	0.32	0.87	89.0	84.0
0x1C	11100	28	3.94	1.40	0.31	0.88	92.0	90.9
0x1D	11101	29	4.06	1.37	0.30	0.89	95.0	98.2
0x1E	11110	30	4.19	1.35	0.30	0.90	98.0	106.0
0x1F	11111	31	4.32	1.33	0.29	0.91	101.0	114.4

Series Operation

In series configuration, the effective capacitance between RF+ and RF- ports is represented by C_S

Figure 14. Effective Capacitance Diagram

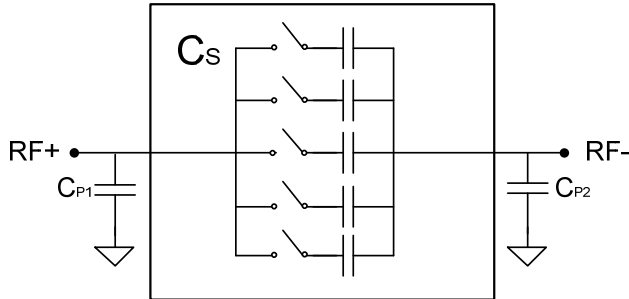

Shunt configuration (looking into RF+ when RF- is grounded) will have higher total capacitance at RF+ due to parallel combination of C_S with parasitic capacitance C_{P1} ($C_S + C_{P1}$), as demonstrated in Figure 15 and Table 9.

Figure 15. Typical Capacitance vs. State

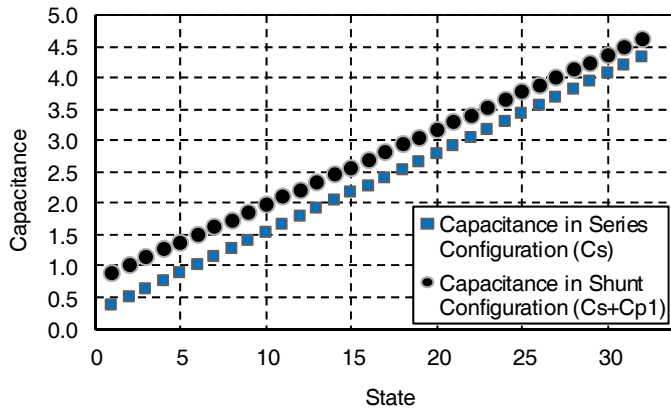

Table 9. Effective Capacitance Summary

Configuration	Effective Capacitance	C_{min} (state 0)	C_{max} (state 31)	Tuning Ratio
Series (RF+ to RF-)	C_S	0.38	4.32	11.4:1
Shunt (RF+ to GND)	$C_S + C_{P1}$	0.90	4.6	5.1:1

S_{11} and S_{21} for series configuration is illustrated in Figures 16 and 17. S_{21} includes mismatch and dissipative losses and is not indicative of tuning network loss. Equivalent Circuit Model can be used for simulation of tuning network loss.

Figure 16. Measured Series S_{11}/S_{22} (major states)

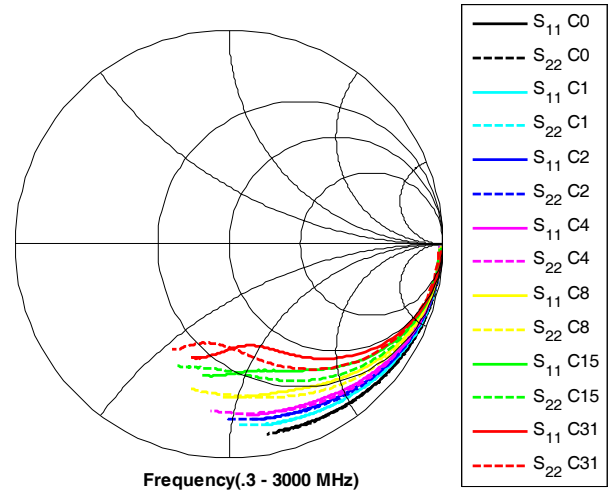
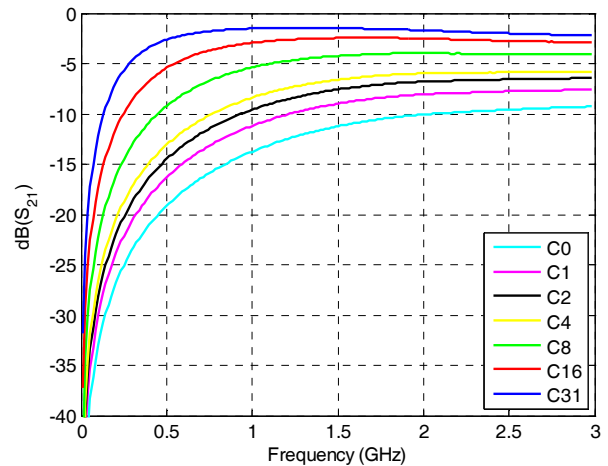

Figure 17. Measured Series S_{21} vs. Frequency



When the DTC is used as a part of a reactive network, impedance transformation may cause the internal RF voltages (V_P and V_M in Figure 13) to exceed peak operating RF voltage. The complete RF circuit must be simulated using actual input power and load conditions to ensure neither V_P nor V_M exceeds $30 V_{PK}$.

Layout Recommendations

For optimal results, place a ground fill directly under the DTC package on the PCB. Layout isolation is desired between all control and RF lines. When using the DTC in a shunt configuration, it is important to make sure the RF-pin is solidly grounded to a filled ground plane. Ground traces should be as short as possible to minimize inductance. A continuous ground plane is preferred on the top layer of the PCB. When multiple DTCs are used together, the physical distance between them should be minimized and the connection should be as wide as possible to minimize series

Figure 18. Recommended Schematic of Multiple DTCs

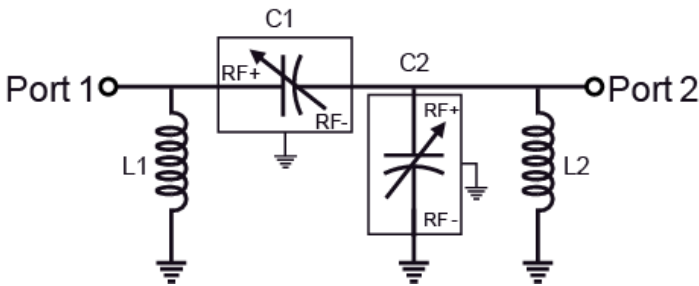
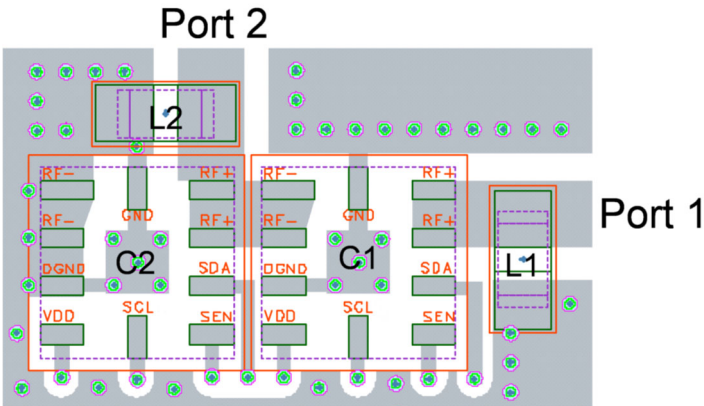

Figure 19. Recommended Layout of Multiple DTCs



Evaluation Board

The 101-0675 Evaluation Board (EVB) was designed for accurate measurement of the DTC impedance and loss. Two configurations are available: 1 Port Shunt (J3) and 2 Port Shunt (J4, J5). Three calibration standards are provided. The open (J2) and short (J1) standards (104 ps delay) are used for performing port extensions and accounting for electrical length and transmission line loss. The Thru (J9, J10) standard can be used to estimate PCB transmission line losses for scalar de-embedding of the 2 Port Series configuration (J4, J5).

The board consists of a 4 layer stack with 2 outer layers made of Rogers 4350B ($\epsilon_r = 3.48$) and 2 inner layers of FR4 ($\epsilon_r = 4.80$). The total thickness of this board is 62 mils (1.57 mm). The inner layers provide a ground plane for the transmission lines. Each transmission line is designed using a coplanar waveguide with ground plane (CPWG) model using a trace width of 32 mils (0.813 mm), gap of 15 mils (0.381 mm), and a metal thickness of 1.4 mils

Figure 20. Evaluation Board Layout

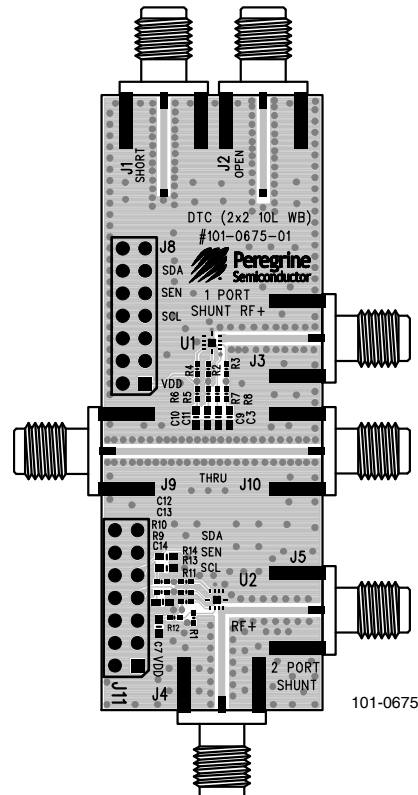

Figure 21. Package Drawing
10-lead 2 x 2 x 0.55 mm QFN

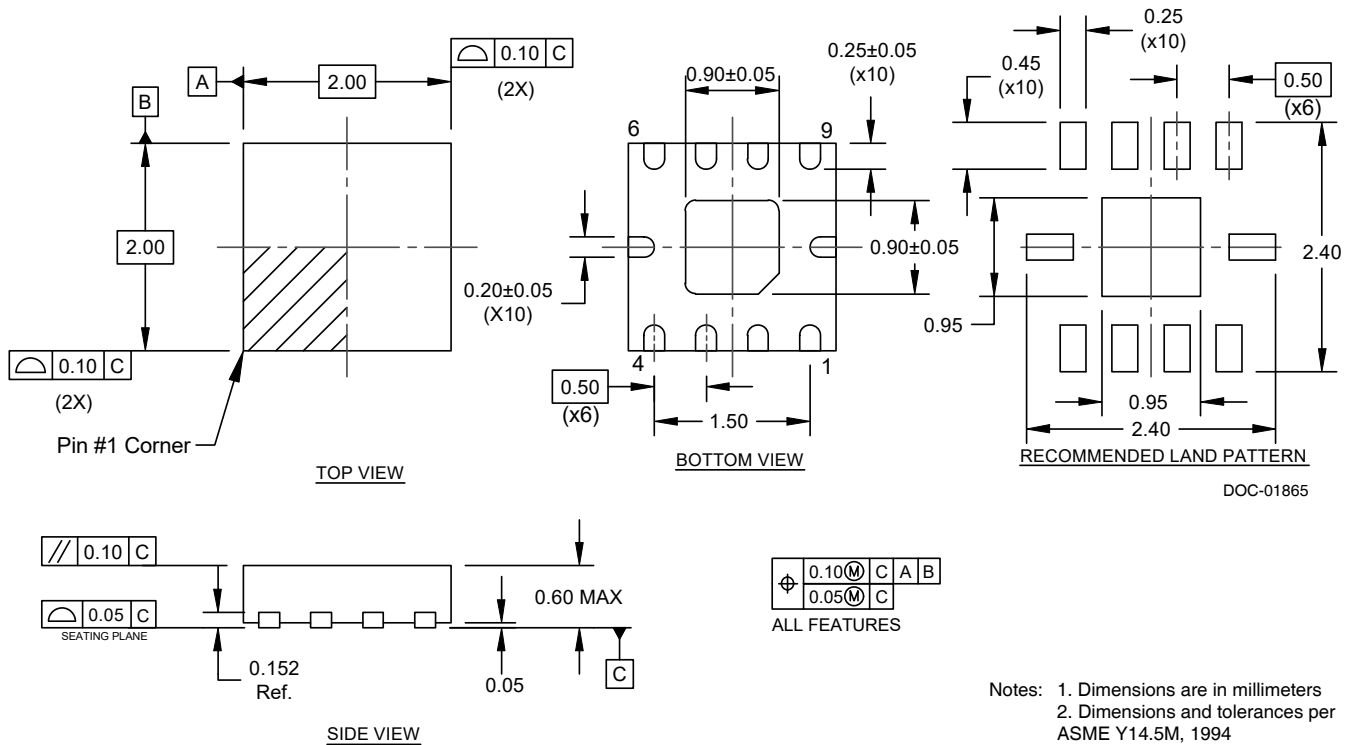
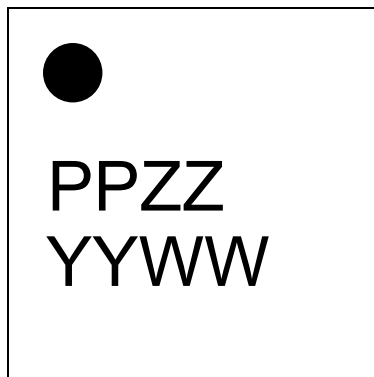

Figure 22. Top Marking Specifications



17-0112

Marking Spec Symbol	Package Marking	Definition
PP	DG*	Part number marking for PE64906
ZZ	00-99	Last two digits of assembly lot code
YY	0-9	Last two digits of assembly year, starting from 2010 (10 for 2010, 11 for 2011, etc.)
WW	01-52	Work week of assembly lot start (01, ..., 52)

* Note: (PP), the package marking specific to the PE64906, is shown in the figure instead of the standard pSemi package marking symbol (P)

Figure 23. Tape and Reel Specifications

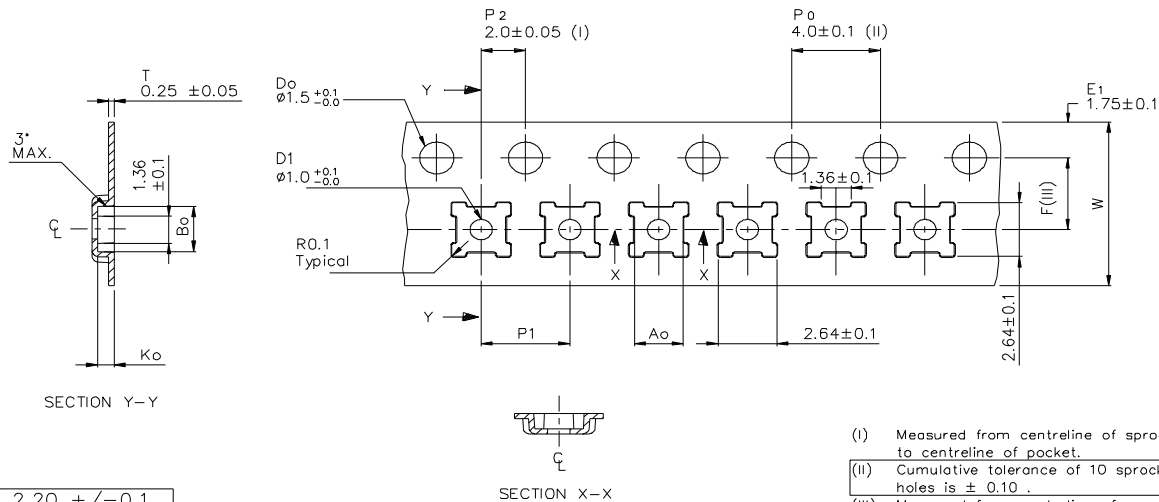

A ₀	2.20 +/−0.1
B ₀	2.20 +/−0.1
K ₀	0.75 +/−0.1
F	3.50 +/−0.05
P ₁	4.00 +/−0.1
W	8.00 +/−0.3

- (I) Measured from centreline of sprocket hole to centreline of pocket.
- (II) Cumulative tolerance of 10 sprocket holes is ± 0.10 .
- (III) Measured from centreline of sprocket hole to centreline of pocket.
- (IV) Other material available.

This part shall not contain any banned substance as Sony standard SS-00259

ALL DIMENSIONS IN MILLIMETRES UNLESS OTHERWISE STATED.

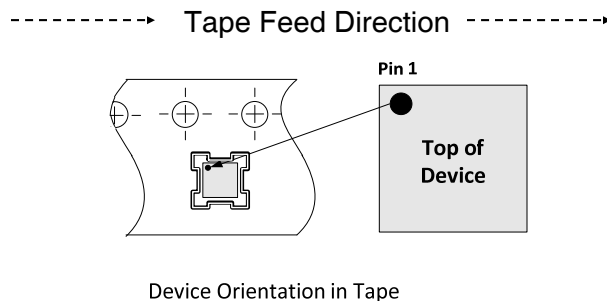

Table 10. Ordering Information

Order Code	Description	Package	Shipping Method
PE64906B-Z	PE64906 DTC	10-lead 2x2 mm QFN	3,000 units/T&R
EK64906-12	PE64906 Evaluation kit	Evaluation kit	1 set/box

Sales Contact and Information

For sales and contact information please visit www.psemi.com.

Advance Information: The product is in a formative or design stage. The datasheet contains design target specifications for product development. Specifications and features may change in any manner without notice.

Preliminary Specification: The datasheet contains preliminary data. Additional data may be added at a later date. pSemi reserves the right to change specifications at any time without notice in order to supply the best possible product. **Product Specification:** The datasheet contains final data. In the event pSemi decides to change the specifications, pSemi will notify customers of the intended changes by issuing a CNF (Customer Notification Form).

The information in this document is believed to be reliable. However, pSemi assumes no liability for the use of this information. Use shall be entirely at the user's own risk.

No patent rights or licenses to any circuits described in this document are implied or granted to any third party. pSemi's products are not designed or intended for use in devices or systems intended for surgical implant, or in other applications intended to support or sustain life, or in any application in which the failure of the pSemi product could create a situation in which personal injury or death might occur. pSemi assumes no liability for damages, including consequential or incidental damages, arising out of the use of its products in such applications.

The Peregrine Semiconductor name, Peregrine Semiconductor logo and UltraCMOS are registered trademarks and the pSemi name, pSemi logo, HaRP and DuNE are trademarks of pSemi Corporation in the U.S. and other countries.

pSemi products are protected under one or more of the following U.S. patents: patents.psemi.com.