



TNC Male Connector Crimp/Crimp Attachment for RG55, RG142, RG223, RG400

RF Connectors Technical Data Sheet

PE4047

Configuration

- TNC Male Connector
- MIL-STD-348A
- 50 Ohms
- Straight Body Geometry
- Connector Interface Types: RG55, RG142, RG223, RG400

Features

- Max. Operating Frequency 6 GHz
- Good VSWR of 1.5:1
- Gold Plated Brass Contact
- 30 µin minimum contact plating

Applications

- General Purpose Test
- Custom Cable Assemblies

Description

Pasternack's PE4047 TNC male connector with crimp/crimp attachment for RG55, RG142, RG223 and RG400 is part of our full line of RF components available for same-day shipping. Our TNC male connector operates up to a maximum frequency of 6 GHz and offers good VSWR of 1.5:1.

Our TNC male connector PE4047 datasheet specifications and drawing with dimensions are shown below in this PDF. Pasternack's broad catalog of RF, microwave and millimeter wave connectors allows designers to configure and customize their signal connections however they like. Whether the need is to provide an I/O for a board design, or simply create a custom cable assembly configuration, Pasternack has the right connector for the job. Pasternack can also expertly build your custom cable assemblies for you and ship same-day.

Electrical Specifications

| Description | Minimum | Typical | Maximum | Units |
|------------------------|---------|---------|---------|-------|
| Frequency Range | DC | | 6 | GHz |
| VSWR | | | 1.5:1 | |
| Operating Voltage (AC) | | | 500 | Vrms |

Mechanical Specifications

Size

| | |
|------------|---------------------|
| Length | 1.097 in [27.86 mm] |
| Width/Dia. | 0.571 in [14.50 mm] |
| Weight | 0.033 lbs [14.97 g] |

Click the following link (or enter part number in "SEARCH" on website) to obtain additional part information including price, inventory and certifications: [TNC Male Connector Crimp/Crimp Attachment for RG55, RG142, RG223, RG400 PE4047](#)



TNC Male Connector Crimp/Crimp Attachment for RG55, RG142, RG223, RG400

RF Connectors Technical Data Sheet

PE4047

Material Specifications

| Description | Material | Plating |
|--------------|----------|---------------------------|
| Contact | Brass | Gold 30 µin minimum |
| Insulation | PTFE | |
| Body | Brass | Nickel 100 µin minimum |
| Coupling Nut | Brass | Nickel 100 µin minimum |
| Crimp Sleeve | Brass | Nickel |

Environmental Specifications

Temperature

Operating Range -65 to +165 deg C

Compliance Certifications (see [product page](#) for current document)

Plotted and Other Data

Notes:

TNC Male Connector Crimp/Crimp Attachment for RG55, RG142, RG223, RG400 from Pasternack Enterprises has same day shipment for domestic and International orders. Our RF, microwave and millimeter wave products maintain a 99.4% availability and are part of the broadest selection in the industry.

Click the following link (or enter part number in "SEARCH" on website) to obtain additional part information including price, inventory and certifications: [TNC Male Connector Crimp/Crimp Attachment for RG55, RG142, RG223, RG400 PE4047](#)

URL: <https://www.pasternack.com/tnc-male-rg55-rg142-rg223-rg400-connector-pe4047-p.aspx>

The information contained in this document is accurate to the best of our knowledge and representative of the part described herein. It may be necessary to make modifications to the part and/or the documentation of the part, in order to implement improvements. Pasternack reserves the right to make such changes as required. Unless otherwise stated, all specifications are nominal. Pasternack does not make any representation or warranty regarding the suitability of the part described herein for any particular purpose, and Pasternack does not assume any liability arising out of the use of any part or documentation.

PE4047 CAD Drawing

TNC Male Connector Crimp/Crimp Attachment for RG55, RG142, RG223, RG400

| REVISIONS | | | |
|-----------|-------------|-----------|----------|
| REV. | DESCRIPTION | DATE | APPROVED |
| A | PCR PE4047 | 6/15/2020 | S.ELLIS |

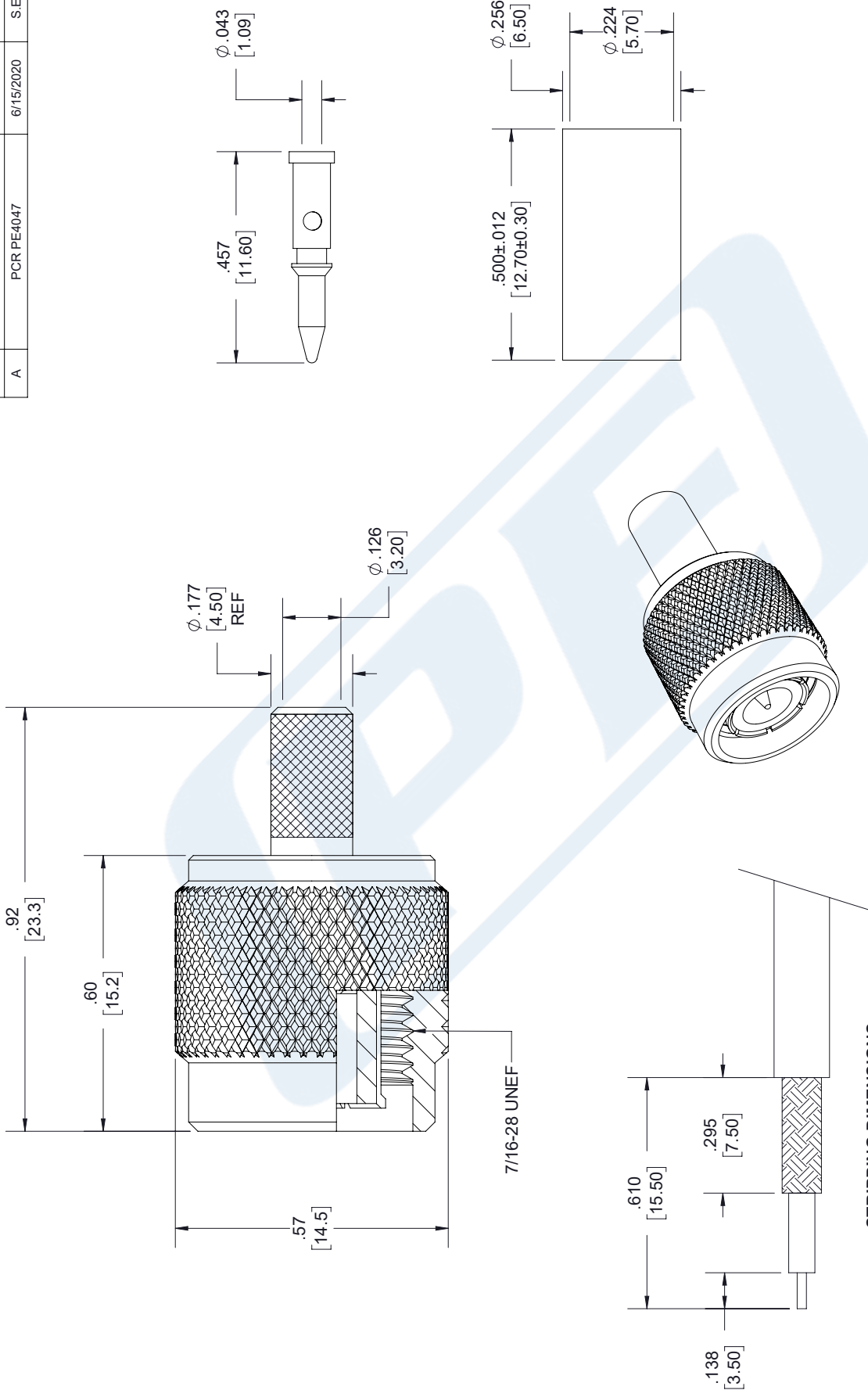

STRIPPING DIMENSIONS

NOTES:

- CABLE ATTACHMENT:
 • OUTER: CRIMP.
 • INNER: SOLDER/CRIMP.
- CRIMP SIZE REQUIRED:
 • FERRULE: .213 [5.41] HEX. CRIMP TOOL.
 • CONTACT: .068 [1.73] HEX. CRIMP TOOL.

UNLESS OTHERWISE SPECIFIED
 LEADING DIMENSIONS ARE INCHES
 DIMENSIONS IN [] ARE MILLIMETERS

TOLERANCES:
 .X = ±.2 [5.08] FRACTIONS ± 1/32
 .XX = ±.02 [.51] ANGLES ± 1°
 .XXX = ±.005 [.13] CABLE LENGTH (L) TOLERANCES:
 L ≤ 12 [305] = +1 [25] / -0
 12 [305] < L ≤ 60 [1524] = +2 [51] / -0
 60 [1524] < L ≤ 120 [3048] = +4 [102] / -0
 120 [3048] < L ≤ 300 [7620] = +6 [152] / -0
 300 [7620] < L = +5% / L / -0
 ALL DIMENSIONS SHOWN
 ARE FOR REFERENCE ONLY.



THE INFORMATION AND
 DESIGN IN THIS DOCUMENT
 IS THE PROPERTY OF
 PASTERNAK CORPORATION
 ALL RIGHTS RESERVED.

SHEET 1 OF 1
 SCALE N/A

REV A



Pasternack Enterprises, Inc.
 P. O. Box 16759, Irvine, CA 92623.
 Phone: 1.949.261.1920 | 1.866.727.8376
 Fax: 1.949.261.7451
 Website: www.pasternack.com
 E-mail: sales@pasternack.com

ITEM NO. PE4047
 DRAWN BY K.DANG
 CAGE CODE A 53919

THESE COMMODITIES, TECHNOLOGY OR SOFTWARE WERE EXPORTED FROM THE UNITED STATES IN ACCORDANCE WITH THE EXPORT ADMINISTRATION REGULATIONS. DIVERSION CONTRARY TO U.S. LAW PROHIBITED.