

IDEAS GENERATED DRAWING, DO NOT CHANGE BY HAND.

D	BC-11-0035559	D.Huang	REV.	ECN. NO.	APPD.
E	BC-11-0064449	D.Huang	A	BC-10-0086220	D. Huang
			B	BC-10-0128464	D. Huang
			C	BC-11-0006981	Tony Hou

NOTES:

1. DIMENSIONING AND TOLERANCING PER ASME Y14.5M-1994.
2. MATERIAL : SOCKET BODY LCP, UL94V-0, BLACK;
CONTACT Cu Ni ALLOY, 15u" MIN. Au PLATING OVER 50u" MIN. Ni UNDERPLATING ON CONTACT AREA;
PICK-UP CAP LCP, UL94V-0, BLACK;
SOLDERBALL LEAD FREE Sn/Ag/Cu BALL;
3. THICKNESS OF SOCKET (FROM SEATING PLANE TO THE BOTTOM OF SOLDER BALLS):
3.4±0.20mm AFTER SOLDERING PROCESS
4. DATE CODE & SOCKET NAME IS LOCATED APPROXIMATELY.
5. FOXCONN LOGO IS LOCATED APPROXIMATELY.
6. HARMFUL MATERIAL CONTROL PLEASE FOLLOWS DOC. NO. "EPI12";
(COMPLIANT TO RoHS)
7. PLEASE CONTACT FOXCONN SALES REPRESENTATIVE TO VERIFY PRODUCT DETAILS & AVAILABILITY.

A
B
C
D
E

A
B
C
D
E

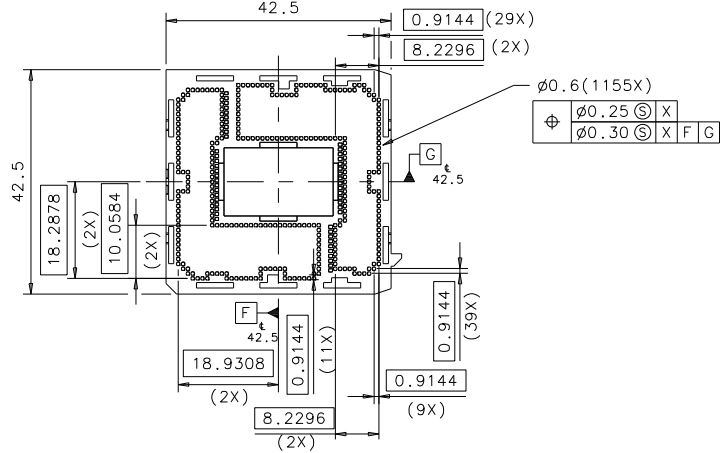
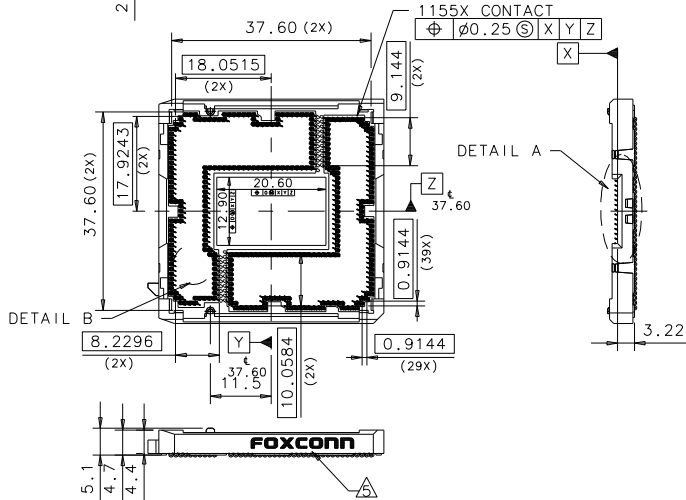
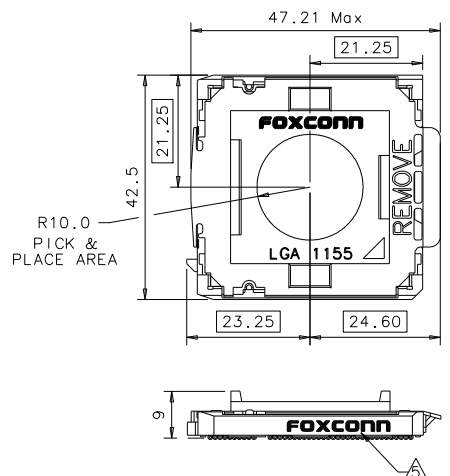
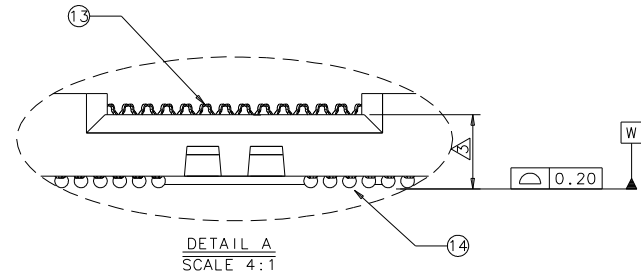
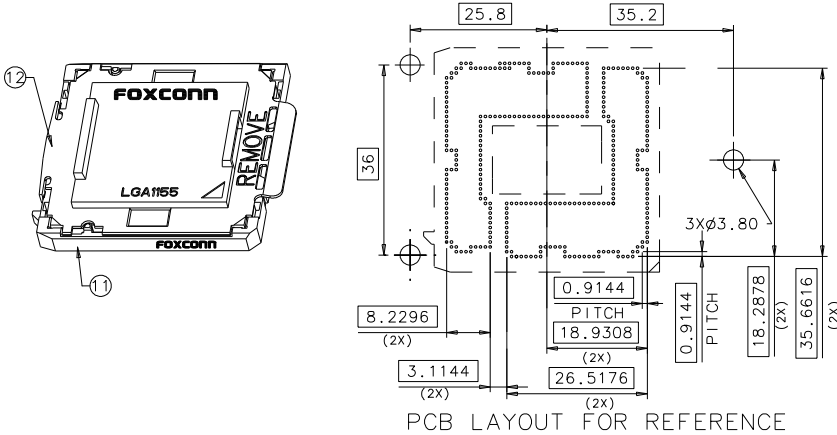

COMPONENT LIST (PE115527-4041-01F)		
ITEM	DESCRIPTION	Q' TY
①	SOCKET BODY	1
②	PICK & PLACE CAP	1
③	CONTACT	1155
④	SOLDER BALL	1155

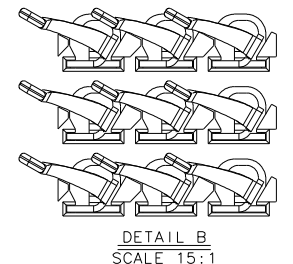

X. ± 0.30	X. ° ± 1°	UNITS	mm	NAME (INTENDED USE) SOCKET OF LGA 1155 SOCKET H2	FOXCONN HON HAI PRECISION IND. CO., LTD. TAIPEI, TAIWAN, R.O.C.
.X ± 0.20	.X ° ±	MAT'L	△		
.XX ± 0.10	.XX ° ±	FINISH		PART NO. (INTENDED USE) PE115527-4041-01F	TITLE: CUSTOMER DRAWING FOR LGA 1155 SOCKET H2
.XXX ±	.XXX ° ±	Q' TY		APPD: Dickie Huang	DWG NO.: 351-0000-1122
THESE DRAWINGS AND SPECIFICATIONS ARE THE PROPERTY OF HON HAI PRECISION IND. CO., LTD. AND SHALL NOT BE REPRODUCED, COPIED OR USED IN ANY MANNER WITHOUT THE PRIOR WRITTEN CONSENT OF HON HAI PRECISION IND. CO., LTD.				CHKD: Mac Peng	SCALE SHEET REV. 2/1 1/1 E
				DR: Terry Liu 06/10'11	