

# PC852 Series PC853/PC853H

\* Lead forming type (I type) and taping reel type (P type) are also available. (PC852I/PC852P/PC853I/PC853P)

## ■ Features

- High collector-emitter voltage  
**PC852 Series, PC853** ( $V_{CEO} : 300V$ )  
**PC853H** ( $V_{CEO} : 350V$ )
- High current transfer ratio  
(CTR: MIN. 1 000% at  $I_F = 1mA, V_{CE} = 2V$ )
- High isolation voltage between input and output ( $V_{iso} : 5\ 000V_{rms}$ )
- Compact dual-in-line package  
**PC852, PC853, PC853H** (1-channel type)

# High Collector-emitter Voltage Type Photocouplers

- PC852I/PC852P/PC853I/PC853P**  
**PC8D52** (2-channel type)  
**PC8Q52** (4-channel type)
- Large collector power dissipation.  
**PC853, PC853H** ( $P_c : 300mW$ )
- Recognized by UL (NO. E64380)

## ■ Applications

- Telephone sets
- Copiers, facsimiles
- Interface with various power supply circuits, power distribution boards
- Numerical control machines

## ■ Outline Dimensions

(Unit : mm)

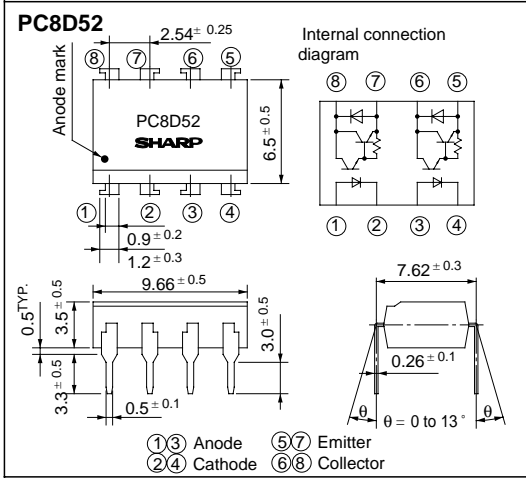
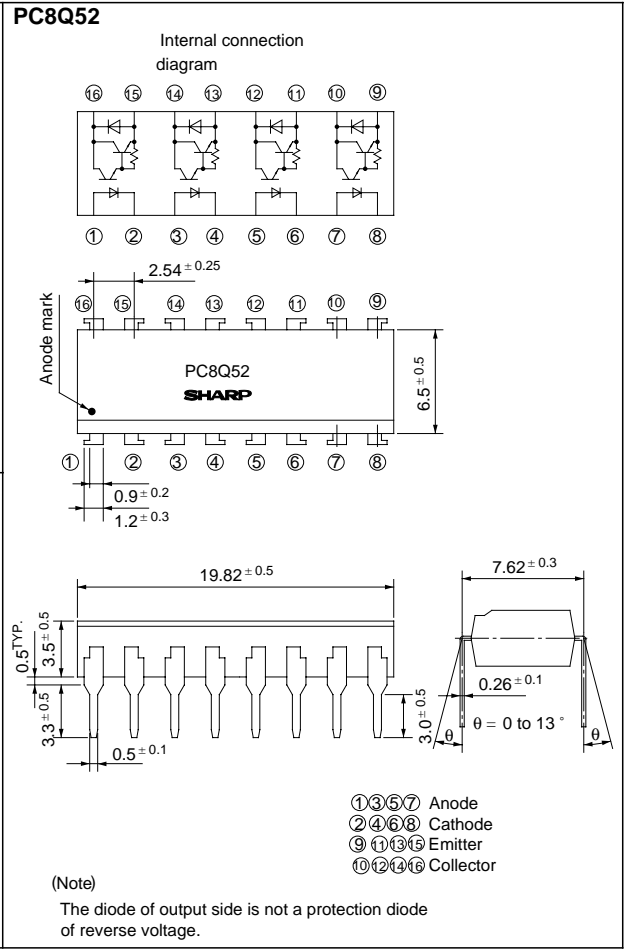
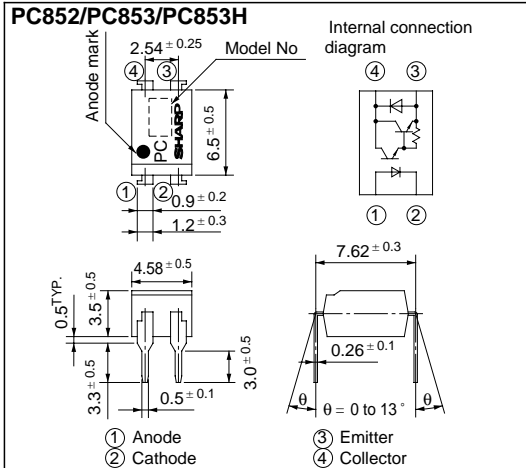

## Absolute Maximum Ratings

(Ta= 25°C)

Parameter	Symbol	Rating			Unit
		PC852 Series	PC853	PC853H	
Input	Forward current	I <sub>F</sub>	50	50	mA
	*1Peak forward current	I <sub>FM</sub>	1	1	A
	Reverse voltage	V <sub>R</sub>	6	6	V
	Power dissipation	P	70	70	mW
Output	Collector-emitter voltage	V <sub>CEO</sub>	300	300   350	V
	Emitter-collector voltage	V <sub>ECO</sub>	0.1	0.1	V
	Collector current	I <sub>C</sub>	150	150	mA
	Collector power dissipation	P <sub>C</sub>	150	300	mW
	Total power dissipation	P <sub>tot</sub>	200	320	mW
*2Isolation voltage	V <sub>iso</sub>	5 000	5 000	V <sub>rms</sub>	
Operating temperature	T <sub>opr</sub>	- 30 to + 100	- 30 to + 100	°C	
Storage temperature	T <sub>stg</sub>	- 55 to + 125	- 55 to + 125	°C	
*3Soldering temperature	T <sub>sol</sub>	260	260	°C	

\*1 Pulse width&lt;=100μs, Duty ratio : 0.001

\*2 40 to 60% RH, AC for 1 minute

\*3 For 10 seconds

## Electro-optical Characteristics

(Ta= 25°C)

Parameter	Symbol	Conditions	MIN.	TYP.	MAX.	Unit	
Input	Forward voltage	V <sub>F</sub>	I <sub>F</sub> = 10mA	-	1.2	1.4	V
	Reverse current	I <sub>R</sub>	V <sub>R</sub> = 4V	-	-	10	μA
	Terminal capacitance	C <sub>t</sub>	V = 0, f = 1kHz	-	30	250	pF
Output	Collector dark current	I <sub>CEO</sub>	V <sub>CE</sub> = 200V, I <sub>F</sub> = 0	-	-	2 x 10 <sup>-7</sup>	A
	Current transfer ratio	CTR	I <sub>F</sub> = 1mA, V <sub>CE</sub> = 2V	1 000	4 000	15 000	%
Transfer characteristics	Collector-emitter saturation voltage	V <sub>CE(sat)</sub>	I <sub>F</sub> = 20mA, I <sub>C</sub> = 100mA	-	-	1.2	V
	Isolation resistance	R <sub>ISO</sub>	DC500V, 40 to 60% RH	5 x 10 <sup>10</sup>	10 <sup>11</sup>	-	Ω
	Floating capacitance	C <sub>f</sub>	V = 0, f = 1MHz	-	0.6	1.0	pF
	Cut-off frequency	f <sub>c</sub>	V <sub>CE</sub> = 2V, I <sub>C</sub> = 20mA, R <sub>L</sub> = 100Ω, - 3dB	1	7	-	kHz
	Response time	Rise time	t <sub>r</sub>	V <sub>CE</sub> = 2V, I <sub>C</sub> = 20mA	-	100	300
Fall time		t <sub>f</sub>	R <sub>L</sub> = 100Ω	-	20	100	μs

**Fig. 1 Forward Current vs. Ambient Temperature**

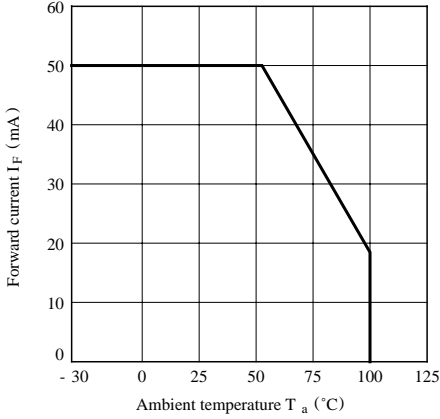

**Fig. 2-a Collector Power Dissipation vs. Ambient Temperature (PC852 Series)**

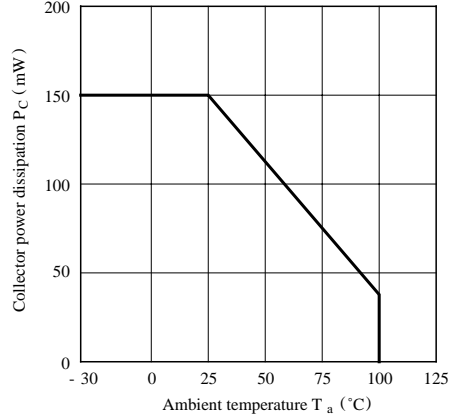

**Fig. 2-b Collector Power Dissipation vs. Ambient Temperature (PC853/PC853H)**

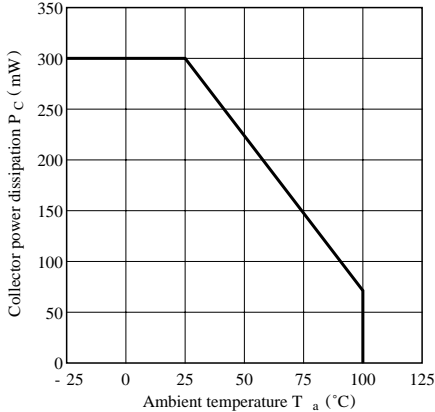

**Fig. 3 Peak Forward Current vs. Duty Ratio**

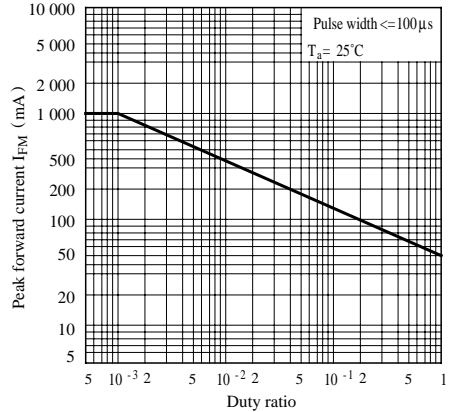

**Fig. 4 Forward Current vs. Forward Voltage**

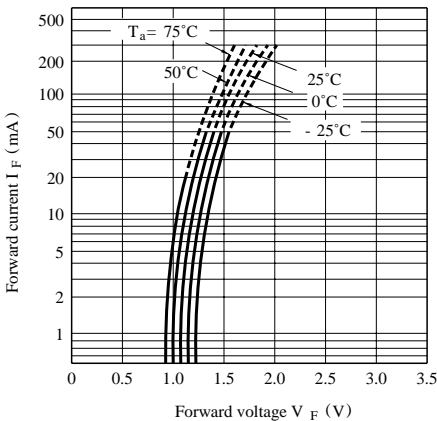

**Fig. 5-a Current Transfer Ratio vs. Forward Current (PC852 Series)**

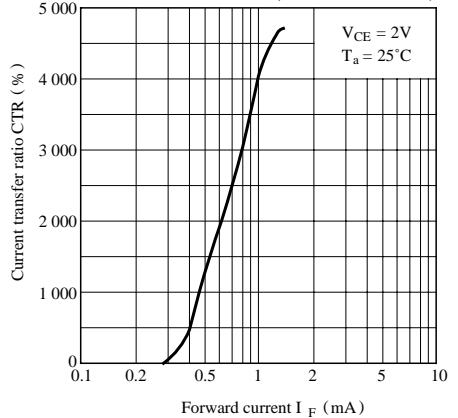

**Fig. 5-b Current Transfer Ratio vs. Forward Current**

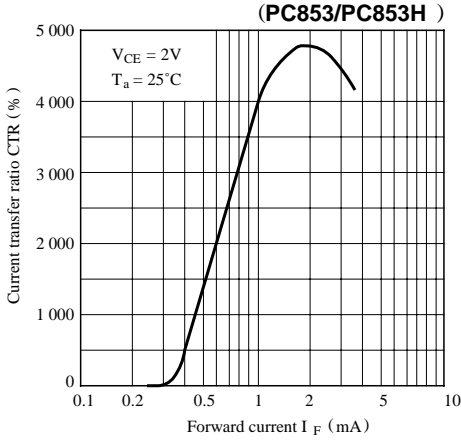

**Fig. 6-a Collector Current vs. Collector-emitter Voltage**  
(PC852 Series)

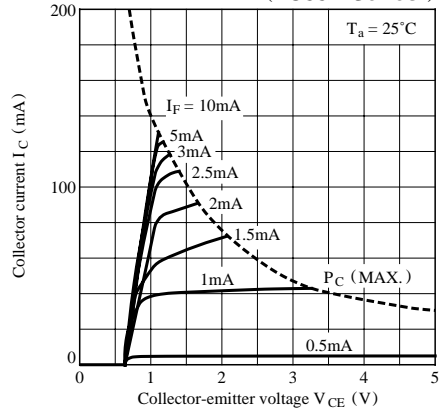

**Fig. 6-b Collector Current vs. Collector-emitter Voltage**  
(PC853 / PC853H)

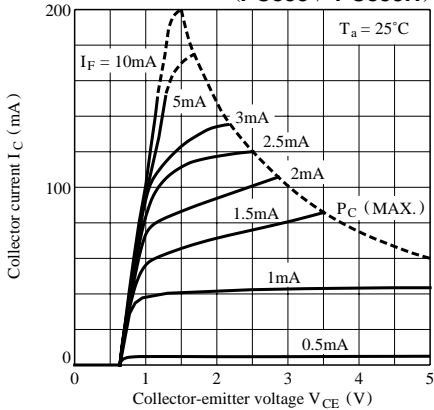

**Fig. 7 Relative Current Transfer Ratio vs. Ambient Temperature**

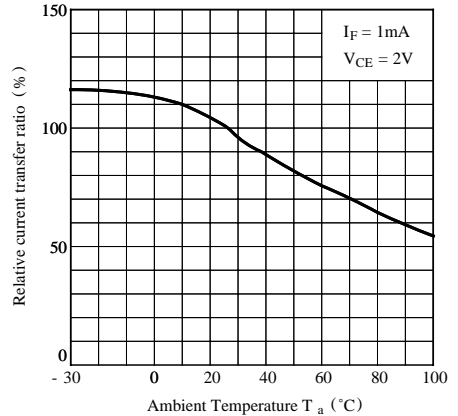

**Fig. 8 Collector-emitter Saturation Voltage vs. Ambient Temperature**

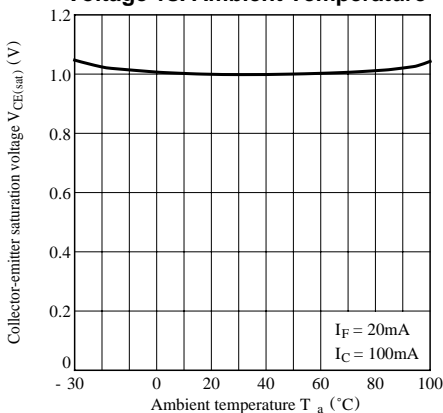

**Fig. 9 Collector Dark Current vs. Ambient Temperature**

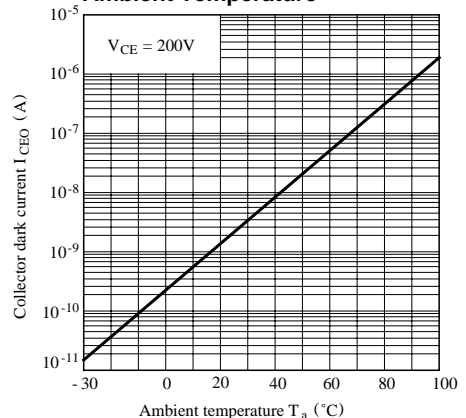

**Fig.10 Response Time vs. Load Resistance**

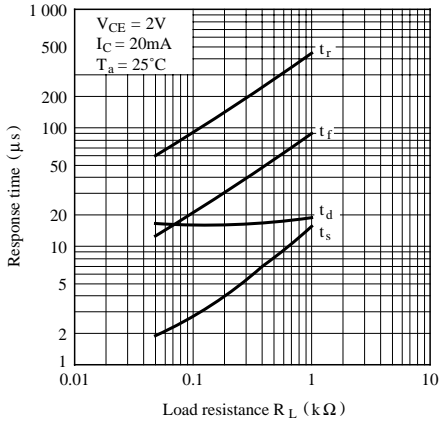

**Fig.11 Frequency Response**

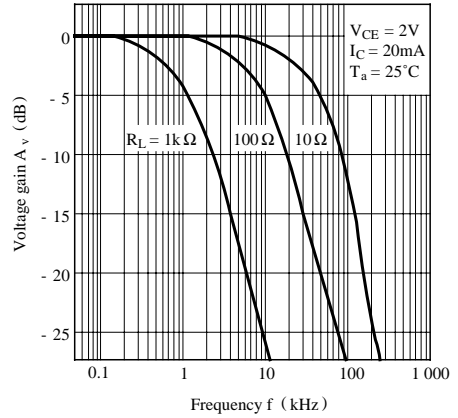

**Fig.12 Collector-emitter Saturation Voltage vs. Forward Current**

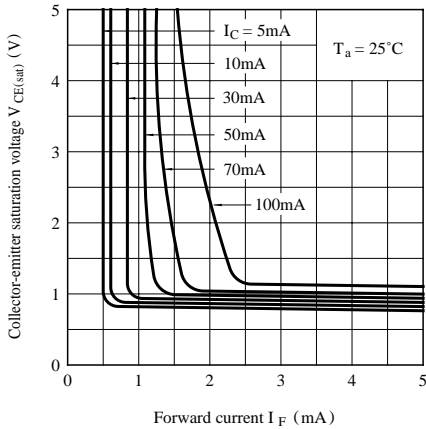

● Please refer to the chapter “Precautions for Use”

### NOTICE

- The circuit application examples in this publication are provided to explain representative applications of SHARP devices and are not intended to guarantee any circuit design or license any intellectual property rights. SHARP takes no responsibility for any problems related to any intellectual property right of a third party resulting from the use of SHARP's devices.
- Contact SHARP in order to obtain the latest device specification sheets before using any SHARP device. SHARP reserves the right to make changes in the specifications, characteristics, data, materials, structure, and other contents described herein at any time without notice in order to improve design or reliability. Manufacturing locations are also subject to change without notice.
- Observe the following points when using any devices in this publication. SHARP takes no responsibility for damage caused by improper use of the devices which does not meet the conditions and absolute maximum ratings to be used specified in the relevant specification sheet nor meet the following conditions:
  - (i) The devices in this publication are designed for use in general electronic equipment designs such as:
    - Personal computers
    - Office automation equipment
    - Telecommunication equipment [terminal]
    - Test and measurement equipment
    - Industrial control
    - Audio visual equipment
    - Consumer electronics
  - (ii) Measures such as fail-safe function and redundant design should be taken to ensure reliability and safety when SHARP devices are used for or in connection with equipment that requires higher reliability such as:
    - Transportation control and safety equipment (i.e., aircraft, trains, automobiles, etc.)
    - Traffic signals
    - Gas leakage sensor breakers
    - Alarm equipment
    - Various safety devices, etc.
  - (iii) SHARP devices shall not be used for or in connection with equipment that requires an extremely high level of reliability and safety such as:
    - Space applications
    - Telecommunication equipment [trunk lines]
    - Nuclear power control equipment
    - Medical and other life support equipment (e.g., scuba).
- Contact a SHARP representative in advance when intending to use SHARP devices for any "specific" applications other than those recommended by SHARP or when it is unclear which category mentioned above controls the intended use.
- If the SHARP devices listed in this publication fall within the scope of strategic products described in the Foreign Exchange and Foreign Trade Control Law of Japan, it is necessary to obtain approval to export such SHARP devices.
- This publication is the proprietary product of SHARP and is copyrighted, with all rights reserved. Under the copyright laws, no part of this publication may be reproduced or transmitted in any form or by any means, electronic or mechanical, for any purpose, in whole or in part, without the express written permission of SHARP. Express written permission is also required before any use of this publication may be made by a third party.
- Contact and consult with a SHARP representative if there are any questions about the contents of this publication.