

# Photoelectrics

## Through-beam, Transistor Output

### Type PB10CNT15..

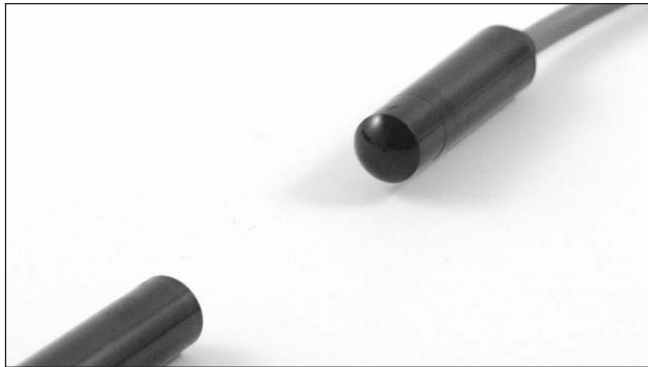

- Elevators, Escalators and Entrance control
- Range 15 m
- Modulated, infrared light
- Supply voltage: 10 to 30 VDC
- Output: 100 mA, NPN or PNP type
- Make or break switching
- LED for output indication or power supply
- Protection: reverse polarity, short circuit, transients
- Cable versions with or without connector
- Emitter mute and power adjustment



### Product Description

The PB10CNT. is a through beam sensor set specially designed for Elevators, Escalators, Entrance control to meet the requirements in the door market. The housing is very robust and is

known for its high long term reliability mute. The emitter has a mute input to turn it off for evaluation of the sensor function. Available in 10-30 VDC version.

### Ordering Key

**PB10CNT15NO-C1**

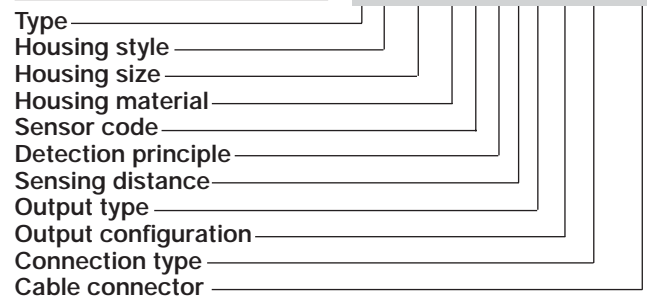

### Type Selection

Housing diameter	Range S <sub>n</sub>	Con- nec- tor	Ordering no. Receiver NPN, NO	Ordering no. Receiver NPN, NC	Ordering no. Receiver PNP, NO	Ordering no. Receiver PNP, NC	Ordering no. Emitter
Ø 10 mm	15 m	NO	PB10CNT15NO	PB10CNT15NC	PB10CNT15PO	PB10CNT15PC	PB10CNT15
Ø 10 mm	15 m	YES	PB10CNT15NO-C1	PB10CNT15NC-C1	PB10CNT15PO-C1	PB10CNT15PC-C1	PB10CNT15-C1

Note: Please order emitter and receiver separately

### Specifications Emitter

Rated operational volt. (U <sub>B</sub> )	10 to 30 VDC	Light source	LED, 880 nm
Ripple (U <sub>rip</sub> )	≤ 10%	Light type	Infrared, modulated
Supply current	≤ 20 mA	Optical angle	± 2°
Protection	Reverse polarity, transients	Indication function	Power supply ON Mute input ON
Control input		Power adjustment	R <sub>x</sub> ~ 3 kΩ - 10 kΩ
Normal oper.	> 1.5 VDC		0 - 100%, in 20 steps
Mute	< 1.2 VDC		

## Specifications Receiver

Rated operating dist. ( $S_n$ )	15 m	Optical angle	$\pm 2^\circ$
Blind zone	None	OFF-state current ( $I_r$ )	$\leq 100 \mu\text{A}$
Temperature drift	$\leq 0.4\%/^\circ\text{C}$	Voltage drop ( $U_d$ )	$\leq 1.6 \text{ VDC @ } 100 \text{ mA}$
Hysteresis (H)	3 - 20%	Protection	Short-circuit, reverse polarity, transients
Rated operational volt. ( $U_B$ )	10 to 30 VDC (ripple included)	Operating frequency (f)	100 Hz
Ripple ( $U_{rp}$ )	$\leq 10\%$	Response time	OFF-ON ( $t_{ON}$ ) $\approx 3.5 \text{ ms}$ ON-OFF ( $t_{OFF}$ ) $\approx 6.5 \text{ ms}$
Output current		Power ON delay ( $t_v$ )	$\leq 300 \text{ ms}$
Continuous ( $I_o$ )	$\leq 100 \text{ mA}$	Output function	NPN or PNP
Short-time (I)	$\leq 100 \text{ mA}$ , (max. load capacity 100 nF)	Indication function	Output ON
No load supply current ( $I_o$ )	$\leq 13 \text{ mA}$		LED, yellow
Minimum operational current ( $I_m$ )	0.5 mA		
Ambient light	$>20.000 \text{ LUX}$		

## General Specifications

Environment		Rated insulation voltage	50 VDC
Overvoltage category	II (IEC 60664/60664A, 60947-1)	Housing material	
Pollution degree	3 (IEC 60664/60664A, 60947-1)	Body	PC black
Degree of protection	IP 67 (IEC 60529, 60947-1)	Connection	
Temperature		Cable	PVC, grey, 5 m, 3 x 0.12 mm <sup>2</sup> , $\varnothing 3.2 \text{ mm}$
Operating	-20° to +50°C (-4° to +122°F)	Weight	
Storage	-25° to +80°C (-13° to +176°F)	Emitter	80 g
Vibration	10 to 150 Hz, 0.5 mm/7.5 g (IEC 60068-2-6)	Receiver	80 g
Shock	2 x 1 m & 100 x 0.5 m (IEC 60068-2-32)	CE-marking	EN12445, EN12453, EN12978

## Operation Diagram

$t_v$  = Power ON delay

Power supply

Target emitter present

Object present

Break (NC) Output ON

Make (NO) Output ON

Mute active  $\leq 1.2 \text{ VDC}$

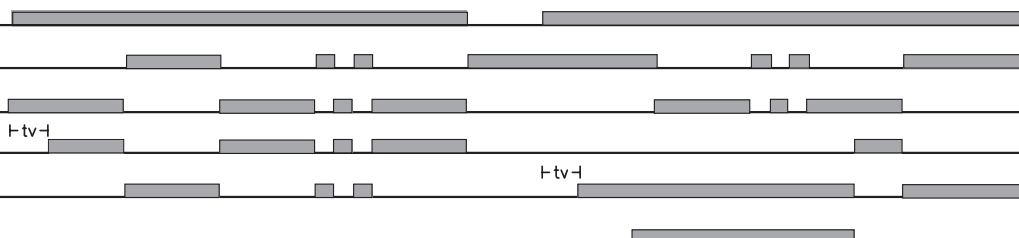

## Installation Hints

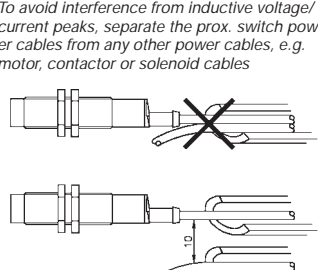
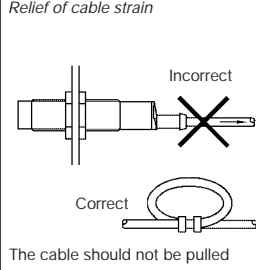
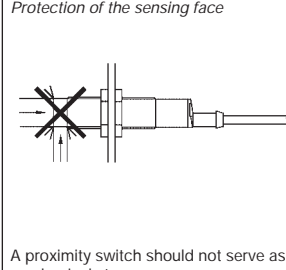
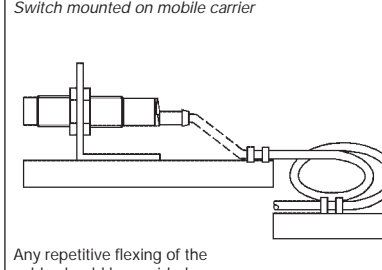
<p>To avoid interference from inductive voltage/current peaks, separate the prox. switch power cables from any other power cables, e.g. motor, contactor or solenoid cables</p> 	<p>Relief of cable strain</p>  <p>The cable should not be pulled</p>	<p>Protection of the sensing face</p>  <p>A proximity switch should not serve as mechanical stop</p>	<p>Switch mounted on mobile carrier</p>  <p>Any repetitive flexing of the cable should be avoided</p>
--------------------------------------------------------------------------------------------------------------------------------------------------------------------------------------------------------------------------------------------------------------------	---------------------------------------------------------------------------------------------------------------------------------------------------------	-----------------------------------------------------------------------------------------------------------------------------------------------------------------------------------------	--------------------------------------------------------------------------------------------------------------------------------------------------------------------------------------------

## Dimensions

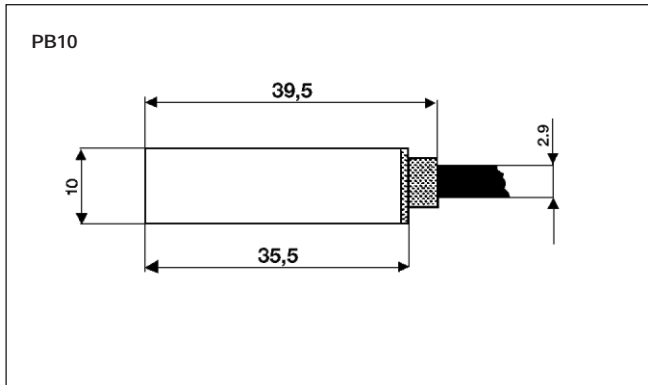

## Detection Diagram

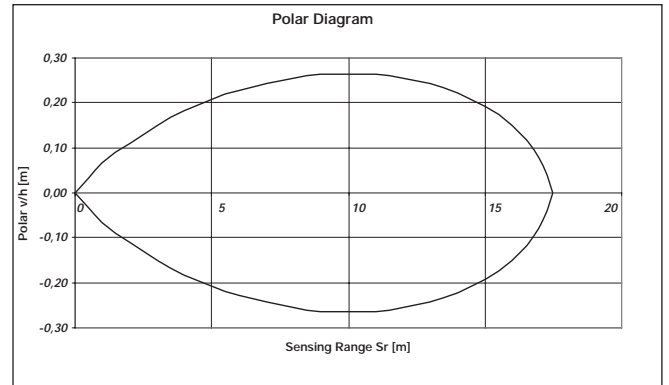

## Wiring Diagram

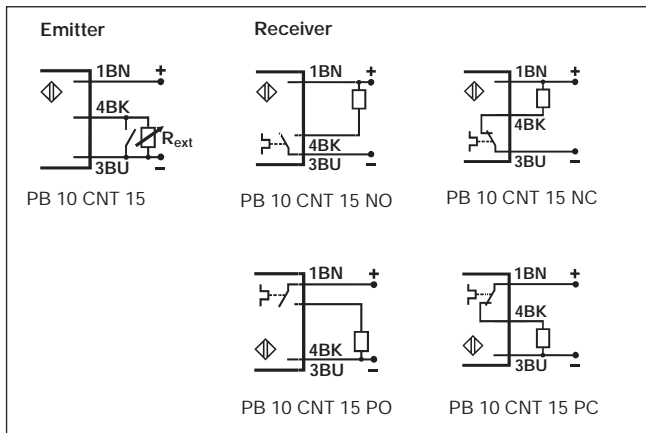

## Excess Gain

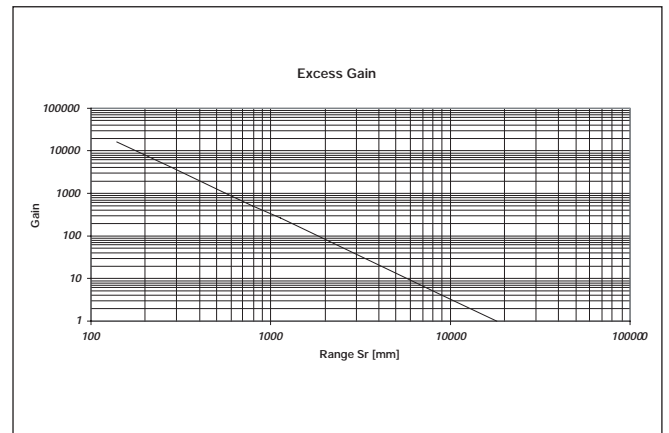

## Delivery Contents

- PB10
- Installation instruction
- **Packaging:** plastic bag