

# Fiber Optic Detector

## OPF430



### Features:

- Electrically isolated metal can package
- High speed, low capacitance
- Metal can for improved noise immunity
- 100MHz operation minimum

### Description:

The OPF430 is a low noise silicon PIN photodiode mounted in a low cost package for fiber optic applications. It offers fast response at moderate bias and is compatible with LED and laser diode sources in the 800-1000 nm wavelength region. Low capacitance improves signal to noise performance in typical short haul LAN applications.

The OPF430 is designed to be compatible with multimode optical fibers from 50/125 to 200/300 microns.

### Applications:

- Industrial Ethernet equipment
- Copper-to-fiber media conversion
- Intra system fiber optic links
- Video surveillance systems

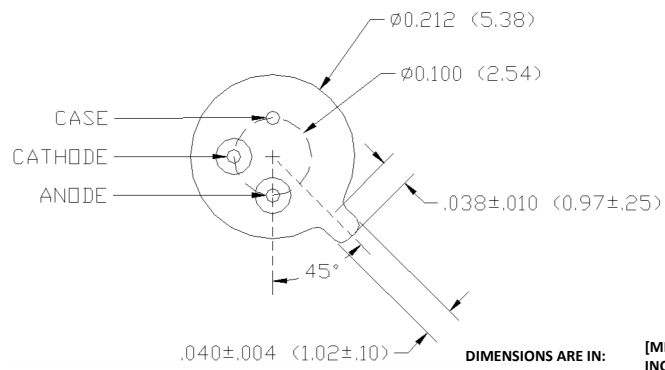
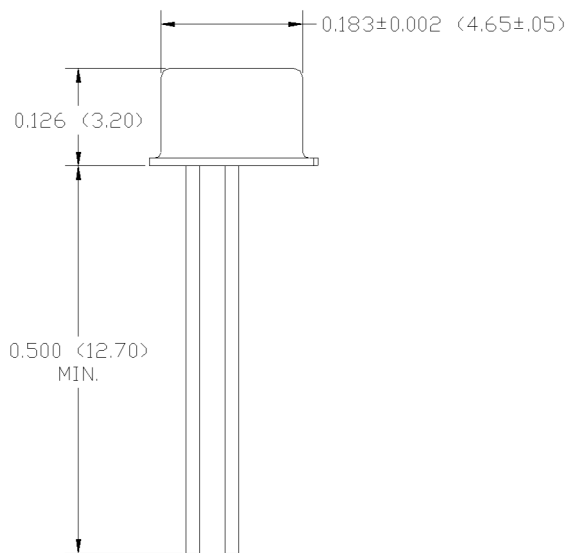

### General Note

TT Electronics reserves the right to make changes in product specification without notice or liability. All information is subject to TT Electronics' own data and is considered accurate at time of going to print.

### Electrical Specifications

#### Absolute Maximum Ratings ( $T_A = 25\text{ °C}$ unless otherwise noted)

Storage Temperature Range	-65 °C to +150 °C
Operating Temperature Range	-55 °C to +125 °C
Lead Soldering Temperature <sup>(1)</sup>	260 °C
Continuous Power Dissipation <sup>(2)</sup>	200 mW
Maximum Reverse Voltage	100 VDC

#### Electrical Characteristics ( $T_A = 25\text{ °C}$ unless otherwise noted)

SYMBOL	PARAMETER	MIN	TYP	MAX	UNITS	TEST CONDITIONS
R	Responsivity	0.45	0.55		A/W	$V_R = 5.0\text{ V}$ ; 50/125 $\mu\text{m}$ fiber; $\lambda = 850\text{ nm}$
$I_D$	Dark Current		0.1	5.0	nA	$V_R = 5.0\text{ V}$
$\lambda_p$	Peak Response Wavelength		905		nm	
$t_r$	Output Rise Time		2.0		ns	$V_R = 5\text{ V}$ ; $R_L = 50\ \Omega$ , 10%-90%
$C_T$	Total Capacitance		1.5	2.0	pF	$V_R = 5\text{ V}$
FoV	Field of View		80		deg	

#### Notes:

1. Maximum of 5 seconds with soldering iron. Duration can be extended to 10 seconds when flow soldering. RMA flux is recommended.
2. De-rate linearly at 1.60 mW/°C above 25 °C.

#### General Note

TT Electronics reserves the right to make changes in product specification without notice or liability. All information is subject to TT Electronics' own data and is considered accurate at time of going to print.

### Performance

#### Typical Responsivity

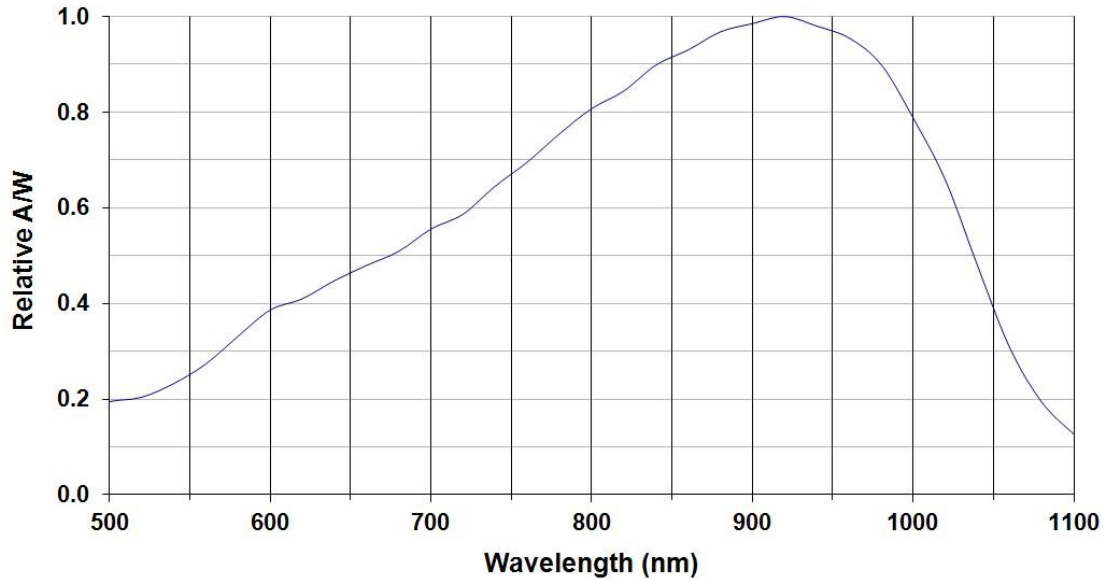

#### Dark Current vs. Temperature

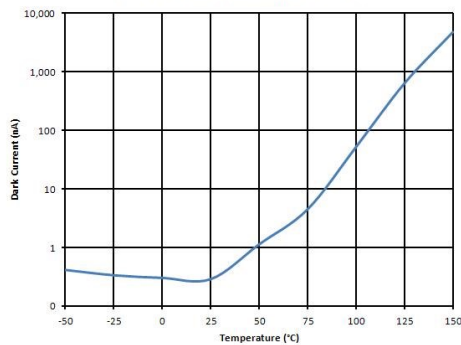

#### Capacitance vs. Bias Voltage

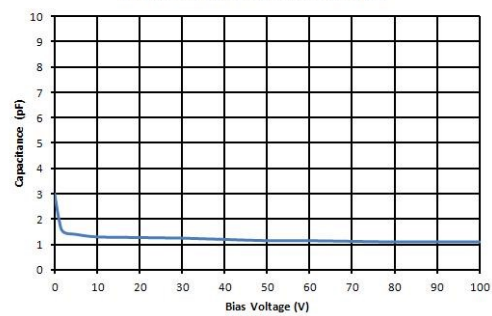

#### Dark Current vs. Bias Voltage

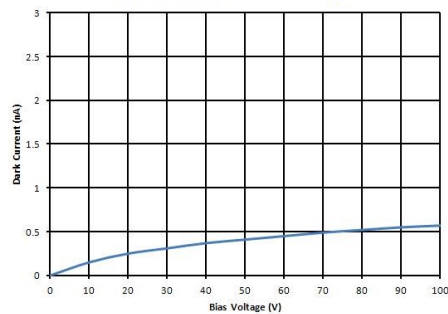

#### General Note

TT Electronics reserves the right to make changes in product specification without notice or liability. All information is subject to TT Electronics' own data and is considered accurate at time of going to print.

TT Electronics | OPTEK Technology  
1645 Wallace Drive, Carrollton, TX 75006 | Ph: +1 972 323 2200  
www.ttelectronics.com | sensors@ttelectronics.com