

OGP280

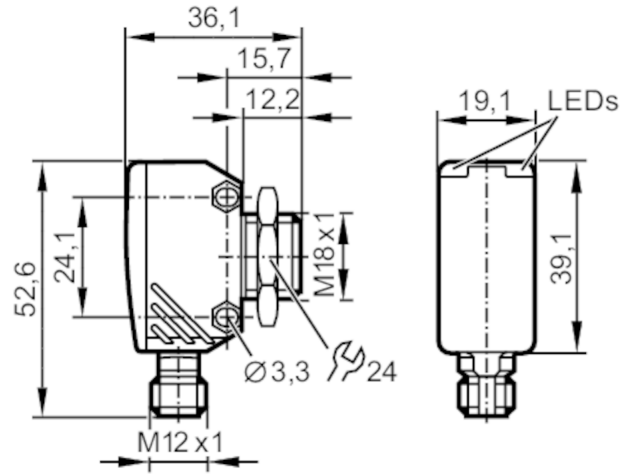

Retro-reflective sensor

OGP-DPKG/US/CUBE



transmitter in lower lens
Receiver in upper lens



Product characteristics

Type of light	red light
Communication interface	IO-Link
Housing	rectangular
Dimensions [mm]	M18 x 1

Application

System	polarization filter
Function principle	Retro-reflective sensor

Electrical data

Operating voltage [V]	10...30 DC; (cULus - Class 2 source required)
Rated insulation voltage [V]	32
Current consumption [mA]	21
Protection class	III
Reverse polarity protection	yes
Max. power-on delay time [ms]	300
Type of light	red light
Wave length [nm]	662

Outputs

Electrical design	PNP
Output function	dark-on mode
Max. voltage drop switching output DC [V]	2.5
Permanent current rating of switching output DC [mA]	200
Switching frequency DC [Hz]	1000
Short-circuit protection	yes
Type of short-circuit protection	yes (non-latching)



Retro-reflective sensor

OGP-DPKG/US/CUBE

Monitoring range		
Range referred to prismatic reflector	[m]	0.1...4; (Prismatic reflector Ø 80 E20005)
Max. light spot diameter	[mm]	160
Light spot dimensions refer to		at maximum range
Polarization filter available		yes
Interfaces		
Communication interface		IO-Link
Transmission type		COM2 (38,4 kBaud)
IO-Link revision		1.1
SDCI standard		IEC 61131-9
IO-Link device ID		1134 d / 00 04 6E h
Profiles		Smart Sensor: Device Identification; Device Diagnosis; Teach Channel; Switching Channel
SIO mode		yes
Required master port class		A
Min. process cycle time	[ms]	2.5
IO-Link process data (cyclical)	Function	bit length
	device status	4
	binary switching information	1
IO-Link functions (acyclical)		application specific tag; operating hours counter; switching cycles counter
Note		For further information please see the IODD PDF file at "Downloads"
Operating conditions		
Ambient temperature	[°C]	-25...60
Storage temperature	[°C]	-40...60
Protection		IP 67
Tests / approvals		
EMC		EN 60947-5-2
MTTF	[years]	905
UL approval	Ta	-25...60 °C
	Enclosure type	Type 1
	voltage supply	Class 2
	File number UL	E174191
Mechanical data		
Weight	[g]	68.8
Housing		rectangular
Dimensions	[mm]	M18 x 1
Thread designation		M18 x 1
Material		diecast zinc; PEI
Lens material		PMMA
Displays / operating elements		
Display	Switching status	1 x LED, yellow
	Power	1 x LED, green
Accessories		
Accessories (supplied)		lock nut: 1 x

OGP280



Retro-reflective sensor

OGP-DPKG/US/CUBE

Remarks

Remarks	cULus - Class 2 source required
Pack quantity	1 pcs.

Electrical connection

Connector: 1 x M12



Connection

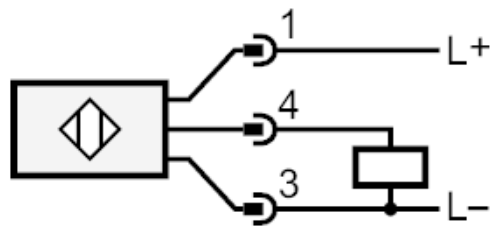

OGP280



Retro-reflective sensor

OGP-DPKG/US/CUBE

Diagrams and graphs

excess gain graph

