

O5H200

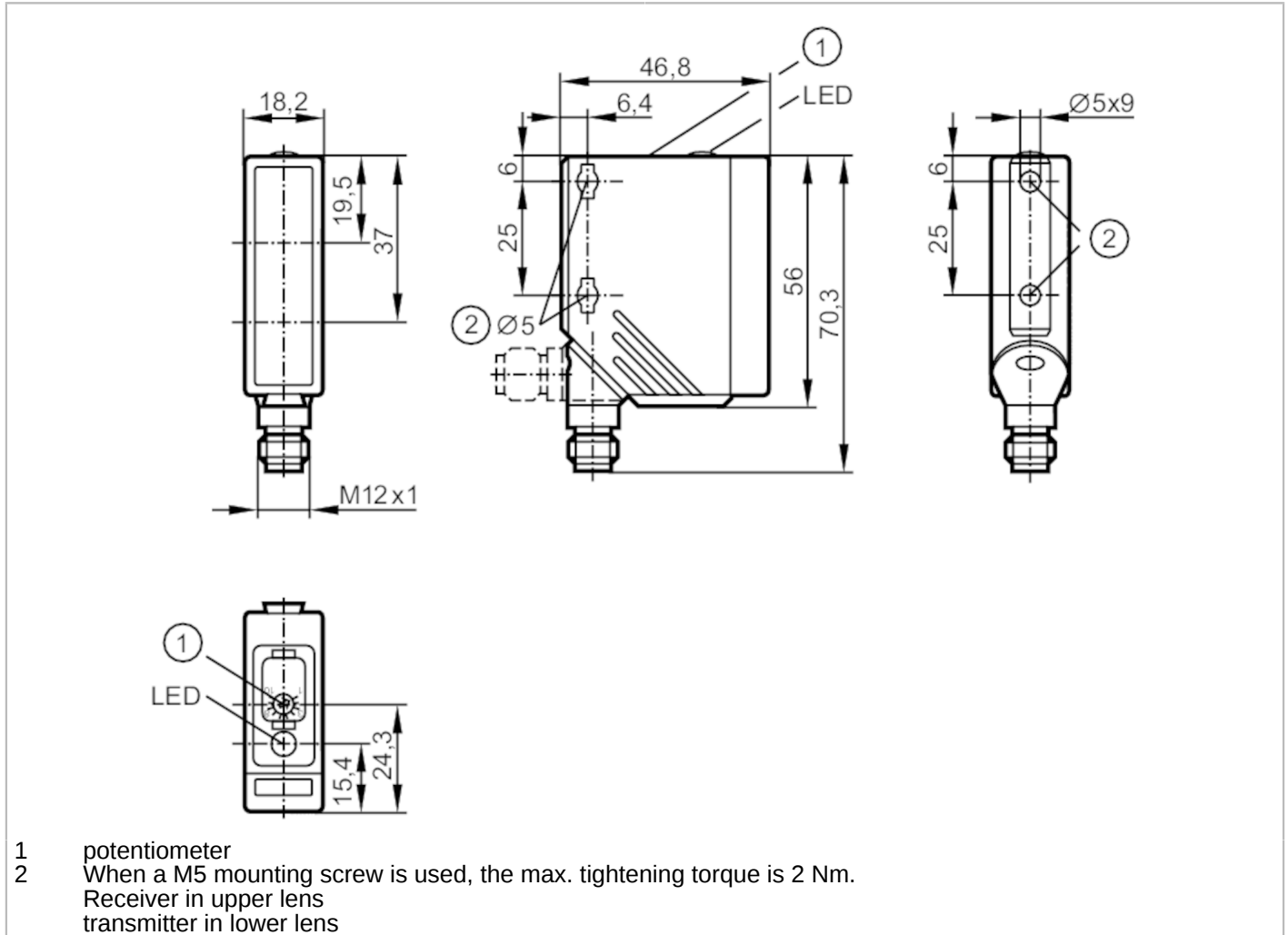

Diffuse reflection sensors with background suppression

O5H-HPKG/US100



Product characteristics

Type of light	red light
Housing	rectangular
Dimensions [mm]	56 x 18.2 x 46.8

Application

System	Background suppression
Function principle	Diffuse reflection sensor

Electrical data

Operating voltage [V]	10...36 DC
Current consumption [mA]	25
Protection class	II
Reverse polarity protection	yes
Type of light	red light
Wave length [nm]	624

O5H200



Diffuse reflection sensors with background suppression

O5H-HPKG/US100

Outputs		
Electrical design		PNP
Output function		light-on mode
Max. voltage drop switching output DC	[V]	2.5
Permanent current rating of switching output DC	[mA]	200
Switching frequency DC	[Hz]	1000
Short-circuit protection		yes
Type of short-circuit protection		yes (non-latching)
Overload protection		yes
Monitoring range		
Range	[mm]	50...1400; (white paper 200 x 200 mm 90 % remission)
Range on white object (90 % remission)	[mm]	50...1400
Range on grey object (18 % remission)	[mm]	50...800
Range on black object (6 % remission)	[mm]	50...550
Range adjustable		yes
Max. light spot diameter	[mm]	50
Light spot dimensions refer to		Range
Background suppression available		yes
Operating conditions		
Ambient temperature	[°C]	-25...60
Protection		IP 65
Tests / approvals		
EMC		EN 60947-5-2
MTTF	[years]	331
Mechanical data		
Weight	[g]	62.5
Housing		rectangular
Dimensions	[mm]	56 x 18.2 x 46.8
Material		housing: PA; Front framework: stainless steel; operator interface: TPE
Lens material		PMMA
Lens alignment		Side sensing
Displays / operating elements		
Display	Switching status	1 x LED, yellow
Operating elements		potentiometer
Remarks		
Remarks		cULus - Class 2 source required
Pack quantity		1 pcs.
Electrical connection		
Connector: 1 x M12		

O5H200



Diffuse reflection sensors with background suppression

O5H-HPKG/US100



Connection

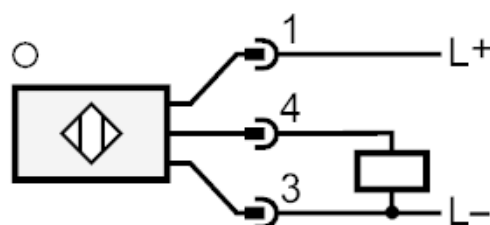

Diagrams and graphs

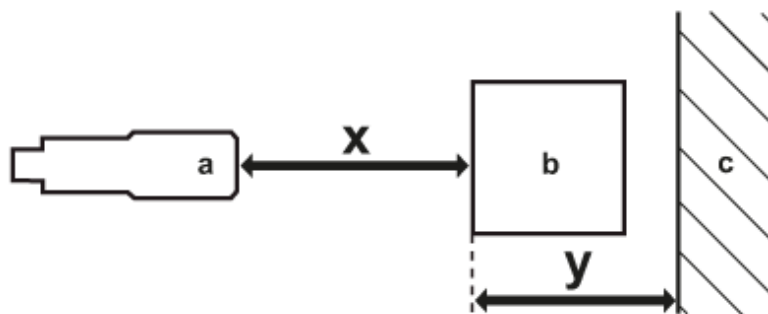

- a: sensor
- b: object
- c: background
- x: distance sensor/object [mm]
- y: min. distance object/background [mm]



Diffuse reflection sensors with background suppression

O5H-HPKG/US100

Background suppression chart

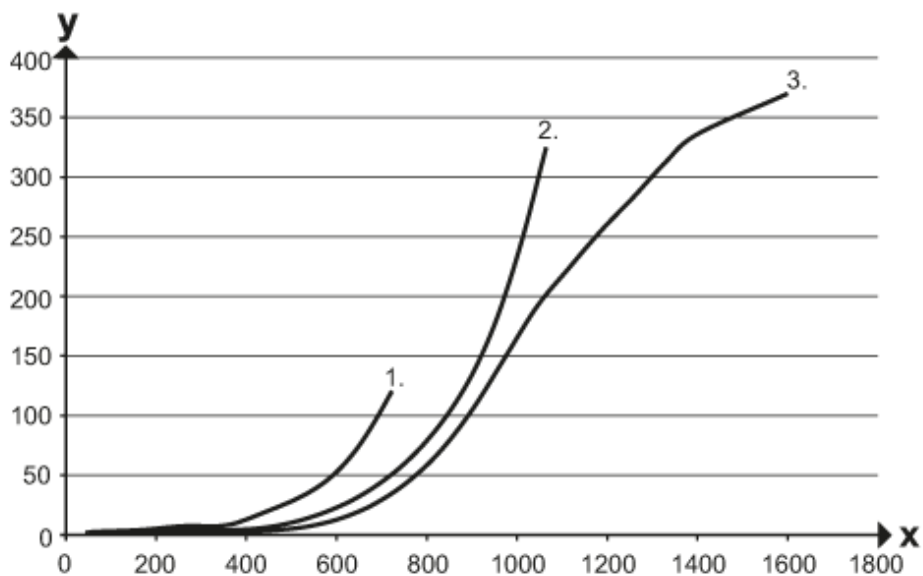

x: distance sensor/object [mm]

y: min. distance object/background [mm]

1 = object black (6 % remission) , background (white 90 % remission)

2 = object grey (18 % remission) , background (white 90 % remission)

3 = object white (90 % remission) , background (white 90 % remission)