

NXB0106

Dual supply translating transceiver; auto direction sensing;
3-state

Rev. 1 — 2 August 2023

Product data sheet

1. General description

The NXB0106 is an 6-bit, dual supply translating transceiver with auto direction sensing, that enables bidirectional voltage level translation. It features two 6-bit input-output ports (An and Bn), one output enable input (OE) and two supply pins ($V_{CC(A)}$ and $V_{CC(B)}$). $V_{CC(A)}$ can be supplied at any voltage between 1.2 V and 3.6 V and $V_{CC(B)}$ can be supplied at any voltage between 1.65 V and 5.5 V, making the device suitable for translating between any of the low voltage nodes (1.2 V, 1.5 V, 1.8 V, 2.5 V, 3.3 V and 5.0 V).

Pins An and OE are referenced to $V_{CC(A)}$ and pins Bn are referenced to $V_{CC(B)}$. A LOW level at pin OE causes the outputs to assume a high-impedance OFF-state. This device is fully specified for partial power-down applications using I_{OFF} . The I_{OFF} circuitry disables the output, preventing the damaging backflow current through the device when it is powered down.

2. Features and benefits

- Wide supply voltage range:
 - $V_{CC(A)}$: 1.2 V to 3.6 V and $V_{CC(B)}$: 1.65 V to 5.5 V
- I_{OFF} circuitry provides partial Power-down mode operation
- Inputs accept voltages up to 5.5 V
- ESD protection:
 - HBM: ANSI/ESDA/Jedec JS-001 Class 2 exceeds 2500 V for A port
 - HBM: ANSI/ESDA/Jedec JS-001 Class 3B exceeds 15000 V for B port
 - CDM: ANSI/ESDA/Jedec JS-002 Class C3 exceeds 1500 V
- Latch-up performance exceeds 100 mA per JESD 78B Class II
- Specified from $-40\text{ }^{\circ}\text{C}$ to $+85\text{ }^{\circ}\text{C}$ and $-40\text{ }^{\circ}\text{C}$ to $+125\text{ }^{\circ}\text{C}$

3. Ordering information

Table 1. Ordering information

Type number	Package			Version
	Temperature range	Name	Description	
NXB0106PW	$-40\text{ }^{\circ}\text{C}$ to $+125\text{ }^{\circ}\text{C}$	TSSOP16	plastic thin shrink small outline package; 16 leads; body width 4.4 mm	SOT403-1
NXB0106BQ	$-40\text{ }^{\circ}\text{C}$ to $+125\text{ }^{\circ}\text{C}$	DHVQFN16	plastic dual in-line compatible thermal enhanced very thin quad flat package; no leads; 16 terminals; body $2.5 \times 3.5 \times 0.85$ mm	SOT763-1

4. Functional diagram

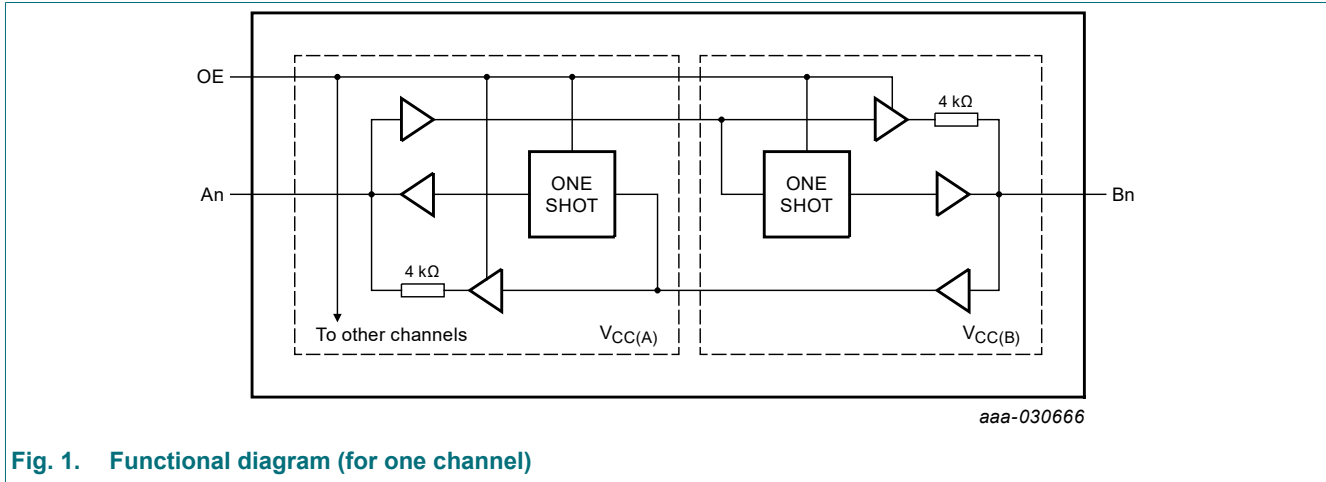
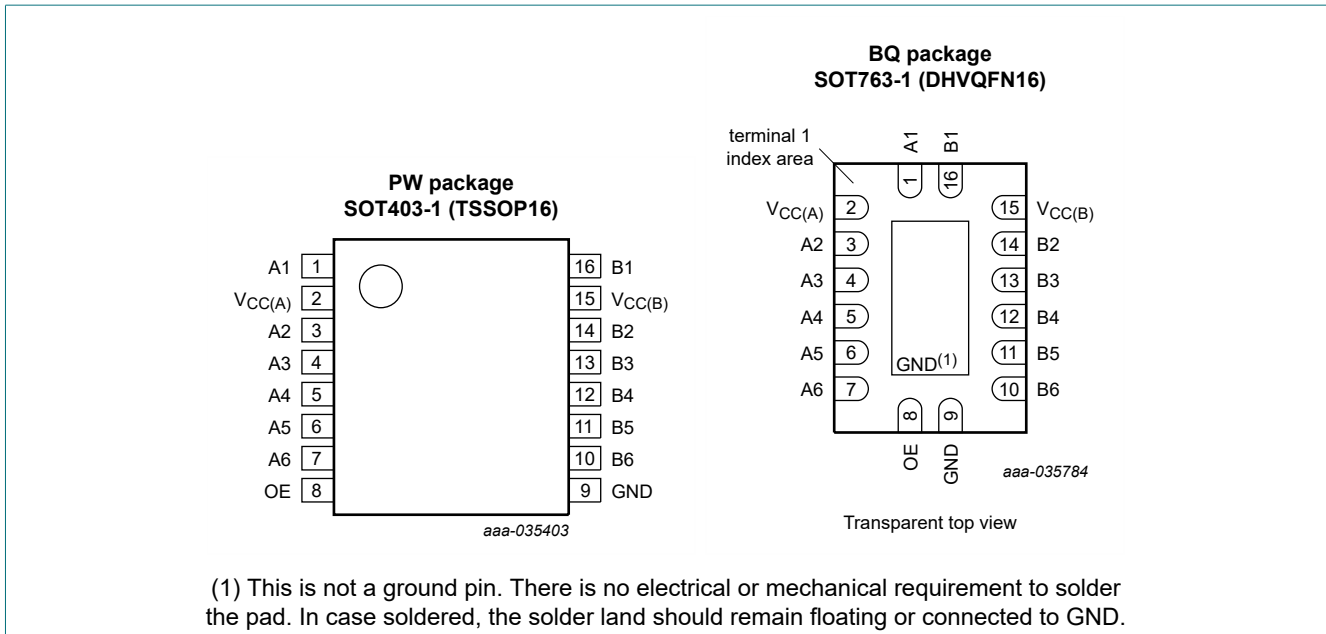

Fig. 1. Functional diagram (for one channel)

5. Pinning information

5.1. Pinning



5.2. Pin description

Table 2. Pin description

Symbol	Pin	Description
A1, A2, A3, A4, A5, A6	1, 3, 4, 5, 6, 7	data input or output (referenced to $V_{CC(A)}$)
$V_{CC(A)}$	2	supply voltage A
OE	8	output enable input (active HIGH; referenced to $V_{CC(A)}$)
GND	9	ground (0 V)
B1, B2, B3, B4, B5, B6	16, 14, 13, 12, 11, 10	data input or output (referenced to $V_{CC(B)}$)
$V_{CC(B)}$	15	supply voltage B

6. Functional description

Table 3. Function table

H = HIGH voltage level; L = LOW voltage level; X = don't care; Z = high-impedance OFF-state.

Supply voltage		Input	Input/output	
$V_{CC(A)}$	$V_{CC(B)}$	OE	An	Bn
1.2 V to $V_{CC(B)}$	1.65 V to 5.5 V	L	Z	Z
1.2 V to $V_{CC(B)}$	1.65 V to 5.5 V	H	input or output	output or input
GND[1]	GND[1]	X	Z	Z

[1] When either $V_{CC(A)}$ or $V_{CC(B)}$ is at GND level, the device goes into power-down mode.

7. Limiting values

Table 4. Limiting values

In accordance with the Absolute Maximum Rating System (IEC 60134). Voltages are referenced to GND (ground = 0 V).

Symbol	Parameter	Conditions	Min	Max	Unit
$V_{CC(A)}$	supply voltage A		-0.5	+6.5	V
$V_{CC(B)}$	supply voltage B		-0.5	+6.5	V
V_I	input voltage		-0.5	+6.5	V
V_O	output voltage	Active mode	-0.5	$V_{CCO} + 0.5$	V
		Power-down or 3-state mode	-0.5	+6.5	V
I_{IK}	input clamping current	$V_I < 0$ V	-50	-	mA
I_{OK}	output clamping current	$V_O < 0$ V	-50	-	mA
I_O	output current	$V_O = 0$ V to V_{CCO}	-	± 50	mA
I_{CC}	supply current	$I_{CC(A)}$ or $I_{CC(B)}$	-	100	mA
I_{GND}	ground current		-100	-	mA
T_{stg}	storage temperature		-65	+150	°C
P_{tot}	total power dissipation	$T_{amb} = -40$ °C to +125 °C	-	500	mW

[1] The minimum input and minimum output voltage ratings may be exceeded if the input and output current ratings are observed.

[2] V_{CCO} is the supply voltage associated with the output.

[3] $V_{CCO} + 0.5$ V should not exceed 6.5 V.

[4] For SOT403-1 (TSSOP16) package: P_{tot} derates linearly with 8.5 mW/K above 91 °C.

For SOT763-1 (DHVQFN16) package: P_{tot} derates linearly with 11.2 mW/K above 106 °C.

8. Recommended operating conditions

Table 5. Recommended operating conditions [1] [2]

Symbol	Parameter	Conditions	Min	Max	Unit
$V_{CC(A)}$	supply voltage A		1.2	3.6	V
$V_{CC(B)}$	supply voltage B		1.65	5.5	V
V_I	input voltage		0	5.5	V
V_O	output voltage	Power-down or 3-state mode; $V_{CC(A)} = 1.2\text{ V to }3.6\text{ V};$ $V_{CC(B)} = 1.65\text{ V to }5.5\text{ V}$			
		A port	0	3.6	V
		B port	0	5.5	V
T_{amb}	ambient temperature		-40	+125	°C
$\Delta t/\Delta V$	input transition rise and fall rate	$V_{CC(A)} = 1.2\text{ V to }3.6\text{ V};$ $V_{CC(B)} = 1.65\text{ V to }5.5\text{ V}$	-	40	ns/V

[1] The A and B sides of an unused I/O pair must be held in the same state, both at V_{CCI} or both at GND.

[2] $V_{CC(A)}$ must be less than or equal to $V_{CC(B)}$.

9. Static characteristics

Table 6. Typical static characteristics

At recommended operating conditions; voltages are referenced to GND (ground = 0 V); $T_{amb} = 25\text{ °C}$.

Symbol	Parameter	Conditions	Min	Typ	Max	Unit
V_{OH}	HIGH-level output voltage	A port; $V_{CC(A)} = 1.2\text{ V}; I_O = -20\text{ }\mu\text{A}$	-	1.1	-	V
V_{OL}	LOW-level output voltage	A port; $V_{CC(A)} = 1.2\text{ V}; I_O = 20\text{ }\mu\text{A}$	-	0.09	-	V
I_I	input leakage current	OE input; $V_I = 0\text{ V to }3.6\text{ V}; V_{CC(A)} = 1.2\text{ V to }3.6\text{ V};$ $V_{CC(B)} = 1.65\text{ V to }5.5\text{ V}$	-	-	± 1	μA
I_{OZ}	OFF-state output current	A or B port; $V_O = 0\text{ V to }V_{CCO}; V_{CC(A)} = 1.2\text{ V to }3.6\text{ V};$ $V_{CC(B)} = 1.65\text{ V to }5.5\text{ V}$	[1]	-	± 1	μA
I_{OFF}	power-off leakage current	A port; V_I or $V_O = 0\text{ V to }3.6\text{ V}; V_{CC(A)} = 0\text{ V};$ $V_{CC(B)} = 0\text{ V to }5.5\text{ V}$	-	-	± 1	μA
		B port; V_I or $V_O = 0\text{ V to }5.5\text{ V}; V_{CC(B)} = 0\text{ V};$ $V_{CC(A)} = 0\text{ V to }3.6\text{ V}$	-	-	± 1	μA
C_I	input capacitance	OE input; $V_{CC(A)} = 1.2\text{ V to }3.6\text{ V}; V_{CC(B)} = 1.65\text{ V to }5.5\text{ V}$	-	5	-	pF
$C_{I/O}$	input/output capacitance	A port; $V_{CC(A)} = 1.2\text{ V to }3.6\text{ V}; V_{CC(B)} = 1.65\text{ V to }5.5\text{ V}$	-	5	-	pF
		B port; $V_{CC(A)} = 1.2\text{ V to }3.6\text{ V}; V_{CC(B)} = 1.65\text{ V to }5.5\text{ V}$	-	8	-	pF

[1] V_{CCO} is the supply voltage associated with the output.

Dual supply translating transceiver; auto direction sensing; 3-state

Table 7. Typical supply current

At recommended operating conditions; voltages are referenced to GND (ground = 0 V); $T_{amb} = 25\text{ }^{\circ}\text{C}$.

$V_{CC(A)}$	$V_{CC(B)}$								Unit
	1.8 V		2.5 V		3.3 V		5.0 V		
	$I_{CC(A)}$	$I_{CC(B)}$	$I_{CC(A)}$	$I_{CC(B)}$	$I_{CC(A)}$	$I_{CC(B)}$	$I_{CC(A)}$	$I_{CC(B)}$	
1.2 V	10	10	10	10	10	20	10	1050	nA
1.5 V	10	10	10	10	10	10	10	650	nA
1.8 V	10	10	10	10	10	10	10	350	nA
2.5 V	-	-	10	10	10	10	10	40	nA
3.3 V	-	-	-	-	10	10	10	10	nA

Table 8. Static characteristics

At recommended operating conditions; voltages are referenced to GND (ground = 0 V).

Symbol	Parameter	Conditions	-40 °C to +85 °C		-40 °C to +125 °C		Unit
			Min	Max	Min	Max	
V_{IH}	HIGH-level input voltage	A or B port and OE input [1]					
		$V_{CC(A)} = 1.2\text{ V to }3.6\text{ V};$ $V_{CC(B)} = 1.65\text{ V to }5.5\text{ V}$	$0.65V_{CCI}$	-	$0.65V_{CCI}$	-	V
V_{IL}	LOW-level input voltage	A or B port and OE input [1]					
		$V_{CC(A)} = 1.2\text{ V to }3.6\text{ V};$ $V_{CC(B)} = 1.65\text{ V to }5.5\text{ V}$	-	$0.35V_{CCI}$	-	$0.35V_{CCI}$	V
V_{OH}	HIGH-level output voltage	A or B port; $I_O = -20\text{ }\mu\text{A}$ [2]					
		A port; $V_{CC(A)} = 1.4\text{ V to }3.6\text{ V}$	$V_{CCO} - 0.4$	-	$V_{CCO} - 0.4$	-	V
		B port; $V_{CC(B)} = 1.65\text{ V to }5.5\text{ V}$	$V_{CCO} - 0.4$	-	$V_{CCO} - 0.4$	-	V
V_{OL}	LOW-level output voltage	A or B port; $I_O = 20\text{ }\mu\text{A}$ [2]					
		A port; $V_{CC(A)} = 1.4\text{ V to }3.6\text{ V}$	-	0.4	-	0.4	V
		B port; $V_{CC(B)} = 1.65\text{ V to }5.5\text{ V}$	-	0.4	-	0.4	V
I_I	input leakage current	OE input; $V_I = 0\text{ V to }3.6\text{ V};$ $V_{CC(A)} = 1.2\text{ V to }3.6\text{ V};$ $V_{CC(B)} = 1.65\text{ V to }5.5\text{ V}$	-	± 2	-	± 5	μA
I_{OZ}	OFF-state output current	A or B port; $V_O = 0\text{ V or }V_{CCO};$ [2] $V_{CC(A)} = 1.2\text{ V to }3.6\text{ V};$ $V_{CC(B)} = 1.65\text{ V to }5.5\text{ V}$	-	± 2	-	± 10	μA
I_{OFF}	power-off leakage current	A port; V_I or $V_O = 0\text{ V to }3.6\text{ V};$ $V_{CC(A)} = 0\text{ V}; V_{CC(B)} = 0\text{ V to }5.5\text{ V}$	-	± 2	-	± 10	μA
		B port; V_I or $V_O = 0\text{ V to }5.5\text{ V};$ $V_{CC(B)} = 0\text{ V}; V_{CC(A)} = 0\text{ V to }3.6\text{ V}$	-	± 2	-	± 10	μA

Dual supply translating transceiver; auto direction sensing; 3-state

Symbol	Parameter	Conditions	-40 °C to +85 °C		-40 °C to +125 °C		Unit
			Min	Max	Min	Max	
I _{CC}	supply current	V _I = 0 V or V _{CCI} ; I _O = 0 A [1]					
		I _{CC(A)}					
		OE = LOW; V _{CC(A)} = 1.4 V to 3.6 V; V _{CC(B)} = 1.65 V to 5.5 V	-	4.3	-	15	μA
		OE = HIGH; V _{CC(A)} = 1.4 V to 3.6 V; V _{CC(B)} = 1.65 V to 5.5 V	-	4.3	-	20	μA
		V _{CC(A)} = 3.6 V; V _{CC(B)} = 0 V	-	1.7	-	15	μA
		V _{CC(A)} = 0 V; V _{CC(B)} = 5.5 V	-	-1.7	-	-15	μA
		I _{CC(B)}					
		OE = LOW; V _{CC(A)} = 1.4 V to 3.6 V; V _{CC(B)} = 1.65 V to 5.5 V	-	4.3	-	20	μA
		OE = HIGH; V _{CC(A)} = 1.4 V to 3.6 V; V _{CC(B)} = 1.65 V to 5.5 V	-	11.1	-	65	μA
		V _{CC(A)} = 3.6 V; V _{CC(B)} = 0 V	-	-1.7	-	-15	μA
		V _{CC(A)} = 0 V; V _{CC(B)} = 5.5 V	-	1.7	-	15	μA
		I _{CC(A)} + I _{CC(B)}					
		V _{CC(A)} = 1.4 V to 3.6 V; V _{CC(B)} = 1.65 V to 5.5 V	-	12.8	-	70	μA

[1] V_{CCI} is the supply voltage associated with the input.

[2] V_{CCO} is the supply voltage associated with the output.

10. Dynamic characteristics

Table 9. Typical dynamic characteristics for temperature 25 °C [1]

Voltages are referenced to GND (ground = 0 V); for test circuit see Fig. 4; for waveforms see Fig. 2 and Fig. 3.

Symbol	Parameter	Conditions	V _{CC(B)}				Unit
			1.8 V	2.5 V	3.3 V	5.0 V	
V_{CC(A)} = 1.2 V; T_{amb} = 25 °C							
t _{pd}	propagation delay	A to B	6.9	5.6	5.1	4.9	ns
		B to A	7.1	5.8	5.0	5.1	ns
t _{en}	enable time	OE to A, B	500	500	500	500	ns
t _{dis}	disable time	OE to A; no external load [2]	14.5	14.5	14.5	14.5	ns
		OE to B; no external load [2]	12.2	10.1	9.3	8.7	ns
		OE to A; see Fig. 3	87	87	87	87	ns
		OE to B; see Fig. 3	98	71	101	68	ns
t _t	transition time	A port	4.2	4.2	4.2	4.2	ns
		B port	2.7	2.0	1.7	1.5	ns
t _{sk(o)}	output skew time	between channels [3]	1.4	0.7	0.6	0.5	ns
t _W	pulse width	data inputs	13	13	13	13	ns
f _{data}	data rate		60	60	60	60	Mbps

[1] t_{pd} is the same as t_{PLH} and t_{PHL}.

t_{en} is the same as t_{PZL} and t_{PZH}.

t_{dis} is the same as t_{PLZ} and t_{PHZ}.

t_t is the same as t_{THL} and t_{TLH}.

[2] These values are guaranteed by design.

[3] Skew between any two outputs of the same package switching in the same direction.

Table 10. Dynamic characteristics for temperature range -40 °C to +85 °C [1]

Voltages are referenced to GND (ground = 0 V); for test circuit see Fig. 4; for waveforms see Fig. 2 and Fig. 3.

Symbol	Parameter	Conditions	V _{CC(B)}								Unit
			1.8 V ± 0.15 V		2.5 V ± 0.2 V		3.3 V ± 0.3 V		5.0 V ± 0.5 V		
			Min	Max	Min	Max	Min	Max	Min	Max	
V_{CC(A)} = 1.5 V ± 0.1 V											
t _{pd}	propagation delay	A to B	1.4	11.4	1.2	8.0	1.1	6.7	0.8	6.2	ns
		B to A	0.9	10.8	0.7	8.3	0.4	7.8	0.3	7.2	ns
t _{en}	enable time	OE to A, B	-	1.0	-	1.0	-	1.0	-	1.0	µs
t _{dis}	disable time	OE to A; no external load [2]	3.4	18.0	3.4	18.0	3.4	18.0	3.4	18.0	ns
		OE to B; no external load [2]	3.4	19.5	3.4	15.0	2.8	13.0	1.6	11.5	ns
		OE to A; see Fig. 3	-	100	-	100	-	100	-	100	ns
		OE to B; see Fig. 3	-	150	-	105	-	150	-	105	ns
t _t	transition time	A port	0.8	6.5	0.8	6.3	0.8	6.3	0.8	6.3	ns
		B port	1.0	7.3	0.7	4.9	0.7	4.6	0.6	4.6	ns
t _{sk(o)}	output skew time	between channels [3]	-	2.6	-	1.9	-	1.6	-	1.3	ns
t _W	pulse width	data inputs	20	-	20	-	20	-	20	-	ns
f _{data}	data rate		-	50	-	50	-	50	-	50	Mbps

Dual supply translating transceiver; auto direction sensing; 3-state

Symbol	Parameter	Conditions	$V_{CC(B)}$								Unit
			$1.8\text{ V} \pm 0.15\text{ V}$		$2.5\text{ V} \pm 0.2\text{ V}$		$3.3\text{ V} \pm 0.3\text{ V}$		$5.0\text{ V} \pm 0.5\text{ V}$		
			Min	Max	Min	Max	Min	Max	Min	Max	
$V_{CC(A)} = 1.8\text{ V} \pm 0.15\text{ V}$											
t_{pd}	propagation delay	A to B	1.6	10.8	1.4	7.9	1.3	6.2	1.2	5.3	ns
		B to A	1.5	9.2	1.3	7.2	0.8	6.3	0.5	5.8	ns
t_{en}	enable time	OE to A, B	-	1.0	-	1.0	-	1.0	-	1.0	μs
t_{dis}	disable time	OE to A; no external load [2]	2.7	13.0	2.7	13.0	2.7	13.0	2.7	13.0	ns
		OE to B; no external load [2]	3.7	18.0	2.8	13.0	2.3	11.5	1.4	9.5	ns
		OE to A; see Fig. 3	-	120	-	120	-	120	-	120	ns
		OE to B; see Fig. 3	-	150	-	105	-	150	-	105	ns
t_t	transition time	A port	0.7	5.1	0.7	5.0	1.0	5.0	0.7	5.0	ns
		B port	1.0	7.3	0.7	5.0	0.7	3.9	0.6	3.8	ns
$t_{sk(o)}$	output skew time	between channels [3]	-	0.8	-	0.7	-	0.6	-	0.6	ns
t_W	pulse width	data inputs	19	-	17	-	17	-	17	-	ns
f_{data}	data rate		-	52	-	60	-	60	-	60	Mbps
$V_{CC(A)} = 2.5\text{ V} \pm 0.2\text{ V}$											
t_{pd}	propagation delay	A to B	-	-	1.1	7.5	1.0	5.2	0.9	4.2	ns
		B to A	-	-	1.0	5.6	0.6	5.0	0.3	4.2	ns
t_{en}	enable time	OE to A, B	-	-	-	1.0	-	1.0	-	1.0	μs
t_{dis}	disable time	OE to A; no external load [2]	-	-	2.3	8.0	2.3	8.0	2.3	8.0	ns
		OE to B; no external load [2]	-	-	1.8	11.5	2.5	9.5	1.1	8.0	ns
		OE to A; see Fig. 3	-	-	-	85	-	85	-	85	ns
		OE to B; see Fig. 3	-	-	-	105	-	150	-	100	ns
t_t	transition time	A port	-	-	0.8	3.6	0.6	3.6	0.5	3.5	ns
		B port	-	-	0.6	4.9	0.7	3.9	0.6	3.2	ns
$t_{sk(o)}$	output skew time	between channels [3]	-	-	-	0.4	-	0.3	-	0.3	ns
t_W	pulse width	data inputs	-	-	13	-	10	-	10	-	ns
f_{data}	data rate		-	-	-	80	-	100	-	100	Mbps

Dual supply translating transceiver; auto direction sensing; 3-state

Symbol	Parameter	Conditions	$V_{CC(B)}$								Unit
			1.8 V \pm 0.15 V		2.5 V \pm 0.2 V		3.3 V \pm 0.3 V		5.0 V \pm 0.5 V		
			Min	Max	Min	Max	Min	Max	Min	Max	
$V_{CC(A)} = 3.3 \text{ V} \pm 0.3 \text{ V}$											
t_{pd}	propagation delay	A to B	-	-	-	-	0.9	4.8	0.8	3.9	ns
		B to A	-	-	-	-	0.5	4.3	0.2	3.7	ns
t_{en}	enable time	OE to A, B	-	-	-	-	-	1.0	-	1.0	μs
t_{dis}	disable time	OE to A; no external load [2]	-	-	-	-	1.9	6.5	1.8	6.5	ns
		OE to B; no external load [2]	-	-	-	-	0.9	8.5	1.6	7.0	ns
		OE to A; see Fig. 3	-	-	-	-	-	125	-	125	ns
		OE to B; see Fig. 3	-	-	-	-	-	150	-	100	ns
t_t	transition time	A port	-	-	-	-	0.5	3.0	0.5	3.0	ns
		B port	-	-	-	-	0.7	3.9	0.6	3.2	ns
$t_{sk(o)}$	output skew time	between channels [3]	-	-	-	-	-	0.4	-	0.3	ns
t_W	pulse width	data inputs	-	-	-	-	9.0	-	9.0	-	ns
f_{data}	data rate		-	-	-	-	-	110	-	110	Mbps

[1] t_{pd} is the same as t_{PLH} and t_{PHL} .

t_{en} is the same as t_{PZL} and t_{PZH} .

t_{dis} is the same as t_{PLZ} and t_{PHZ} .

t_t is the same as t_{THL} and t_{TLH} .

[2] These values are guaranteed by design.

[3] Skew between any two outputs of the same package switching in the same direction.

Table 11. Dynamic characteristics for temperature range -40 °C to +125 °C [1]

Voltages are referenced to GND (ground = 0 V); for test circuit see Fig. 4; for waveforms see Fig. 2 and Fig. 3.

Symbol	Parameter	Conditions	$V_{CC(B)}$								Unit
			1.8 V \pm 0.15 V		2.5 V \pm 0.2 V		3.3 V \pm 0.3 V		5.0 V \pm 0.5 V		
			Min	Max	Min	Max	Min	Max	Min	Max	
$V_{CC(A)} = 1.5 \text{ V} \pm 0.1 \text{ V}$											
t_{pd}	propagation delay	A to B	1.4	11.9	1.2	9.0	1.1	7.3	0.8	6.5	ns
		B to A	0.9	10.9	0.7	8.8	0.4	7.9	0.3	7.7	ns
t_{en}	enable time	OE to A, B	-	1.0	-	1.0	-	1.0	-	1.0	μs
t_{dis}	disable time	OE to A; no external load [2]	3.4	19.0	3.4	19.0	3.4	19.0	3.4	19.0	ns
		OE to B; no external load [2]	3.4	22.0	3.4	16.0	2.8	14.0	1.6	12.5	ns
		OE to A; see Fig. 3	-	105	-	105	-	105	-	105	ns
		OE to B; see Fig. 3	-	155	-	110	-	155	-	105	ns
t_t	transition time	A port	0.8	8.1	0.8	7.9	0.8	7.9	0.8	7.9	ns
		B port	1.0	9.1	0.7	6.1	0.7	5.8	0.6	5.8	ns
$t_{sk(o)}$	output skew time	between channels [3]	-	2.6	-	1.9	-	1.6	-	1.3	ns
t_W	pulse width	data inputs	25	-	25	-	25	-	25	-	ns
f_{data}	data rate		-	40	-	40	-	40	-	40	Mbps

Dual supply translating transceiver; auto direction sensing; 3-state

Symbol	Parameter	Conditions	$V_{CC(B)}$								Unit
			$1.8\text{ V} \pm 0.15\text{ V}$		$2.5\text{ V} \pm 0.2\text{ V}$		$3.3\text{ V} \pm 0.3\text{ V}$		$5.0\text{ V} \pm 0.5\text{ V}$		
			Min	Max	Min	Max	Min	Max	Min	Max	
$V_{CC(A)} = 1.8\text{ V} \pm 0.15\text{ V}$											
t_{pd}	propagation delay	A to B	1.6	11.1	1.4	8.1	1.3	6.5	1.2	5.5	ns
		B to A	1.5	9.6	1.2	7.8	0.8	6.6	0.5	6.3	ns
t_{en}	enable time	OE to A, B	-	1.0	-	1.0	-	1.0	-	1.0	μs
t_{dis}	disable time	OE to A; no external load [2]	2.7	14.0	2.7	14.0	2.7	14.0	2.7	14.0	ns
		OE to B; no external load [2]	3.7	20.5	2.8	14.5	2.3	12.5	1.4	10.5	ns
		OE to A; see Fig. 3	-	125	-	125	-	125	-	125	ns
		OE to B; see Fig. 3	-	150	-	105	-	150	-	105	ns
t_t	transition time	A port	0.8	6.4	0.7	6.3	1.0	6.3	0.7	6.3	ns
		B port	1.0	9.1	0.7	6.3	0.7	4.9	0.6	4.8	ns
$t_{sk(o)}$	output skew time	between channels [3]	-	0.8	-	0.7	-	0.6	-	0.6	ns
t_W	pulse width	data inputs	22	-	18	-	18	-	18	-	ns
f_{data}	data rate		-	45	-	55	-	55	-	55	Mbps
$V_{CC(A)} = 2.5\text{ V} \pm 0.2\text{ V}$											
t_{pd}	propagation delay	A to B	-	-	1.1	7.6	1.0	5.8	0.9	4.4	ns
		B to A	-	-	1.0	7.1	0.6	5.1	0.3	4.8	ns
t_{en}	enable time	OE to A, B	-	-	-	1.0	-	1.0	-	1.0	μs
t_{dis}	disable time	OE to A; no external load [2]	-	-	2.3	9.0	2.3	9.0	2.3	9.0	ns
		OE to B; no external load [2]	-	-	1.8	13.0	2.6	10.5	1.1	8.5	ns
		OE to A; see Fig. 3	-	-	-	85	-	85	-	85	ns
		OE to B; see Fig. 3	-	-	-	105	-	150	-	100	ns
t_t	transition time	A port	-	-	0.8	4.5	0.6	4.5	0.5	4.4	ns
		B port	-	-	0.6	6.1	0.7	4.9	0.6	4.0	ns
$t_{sk(o)}$	output skew time	between channels [3]	-	-	-	0.4	-	0.3	-	0.3	ns
t_W	pulse width	data inputs	-	-	13	-	13	-	13	-	ns
f_{data}	data rate		-	-	-	75	-	80	-	80	Mbps

Dual supply translating transceiver; auto direction sensing; 3-state

Symbol	Parameter	Conditions	V _{CC(B)}								Unit
			1.8 V ± 0.15 V		2.5 V ± 0.2 V		3.3 V ± 0.3 V		5.0 V ± 0.5 V		
			Min	Max	Min	Max	Min	Max	Min	Max	
V_{CC(A)} = 3.3 V ± 0.3 V											
t _{pd}	propagation delay	A to B	-	-	-	-	0.9	5.3	0.8	4.2	ns
		B to A	-	-	-	-	0.5	4.4	0.2	4.0	ns
t _{en}	enable time	OE to A, B	-	-	-	-	-	1.0	-	1.0	µs
t _{dis}	disable time	OE to A; no external load [2]	-	-	-	-	1.9	7.0	1.8	7.0	ns
		OE to B; no external load [2]	-	-	-	-	0.9	9.5	1.6	7.5	ns
		OE to A; see Fig. 3	-	-	-	-	-	125	-	125	ns
		OE to B; see Fig. 3	-	-	-	-	-	150	-	100	ns
t _t	transition time	A port	-	-	-	-	0.5	3.8	0.5	3.8	ns
		B port	-	-	-	-	0.7	4.9	0.6	4.0	ns
t _{sk(o)}	output skew time	between channels [3]	-	-	-	-	-	0.4	-	0.3	ns
t _W	pulse width	data inputs	-	-	-	-	10	-	10	-	ns
f _{data}	data rate		-	-	-	-	-	100	-	100	Mbps

- [1] t_{pd} is the same as t_{PLH} and t_{PHL}.
t_{en} is the same as t_{PZL} and t_{PZH}.
t_{dis} is the same as t_{PLZ} and t_{PHZ}.
t_t is the same as t_{THL} and t_{TLH}.
- [2] These values are guaranteed by design.
- [3] Skew between any two outputs of the same package switching in the same direction.

Table 12. Typical power dissipation capacitance [1] [2]

Voltages are referenced to GND (ground = 0 V).

Symbol	Parameter	Conditions	V _{CC(A)}								Unit
			1.2 V	1.2 V	1.5 V	1.8 V	2.5 V	2.5 V	3.3 V		
			V _{CC(B)}								
1.8 V	5.0 V	1.8 V	1.8 V	2.5 V	5.0 V	3.3 V to 5.0 V					
T_{amb} = 25 °C											
C _{PD}	power dissipation capacitance	outputs enabled; OE = V _{CC(A)}									
		A port: (direction A to B)	7.0	6.5	7.2	7.6	7.6	7.0	8.0	pF	
		A port: (direction B to A)	9.6	10.0	9.8	10.1	10.5	10.3	10.8	pF	
		B port: (direction A to B)	23.3	28.7	23.1	23.1	23.7	25.9	25.9	pF	
		B port: (direction B to A)	17.8	25.5	17.1	16.8	17.4	21.0	20.5	pF	
		outputs disabled; OE = GND									
		A port: (direction A to B)	0.2	0.2	0.2	0.3	0.3	0.3	0.3	pF	
		A port: (direction B to A)	0.01	0.01	0.01	0.01	0.01	0.01	0.01	pF	
B port: (direction A to B)	0.01	0.02	0.01	0.01	0.01	0.01	0.01	pF			
B port: (direction B to A)	0.2	0.3	0.2	0.2	0.3	0.3	0.3	pF			

- [1] C_{PD} is used to determine the dynamic power dissipation (P_D in µW). P_D = C_{PD} × V_{CC}² × f_i × N + Σ(C_L × V_{CC}² × f_o) where:
f_i = input frequency in MHz; f_o = output frequency in MHz;
C_L = load capacitance in pF; V_{CC} = supply voltage in V;
N = number of inputs switching; Σ(C_L × V_{CC}² × f_o) = sum of the outputs.
- [2] f_i = 10 MHz; V_i = GND to V_{CC}; t_r = t_f = 1 ns; C_L = 0 pF; R_L = ∞ Ω.

10.1. Waveforms and test circuit

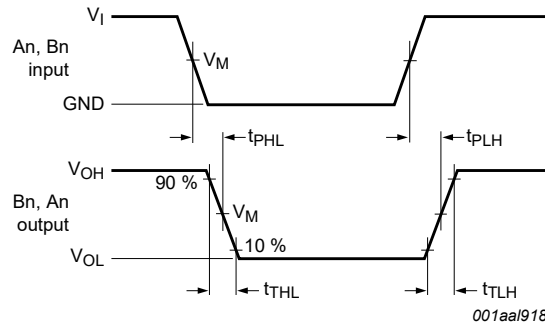

Measurement points are given in Table 13.

V_{OL} and V_{OH} are typical output voltage levels that occur with the output load.

Fig. 2. The data input (An, Bn) to data output (Bn, An) propagation delay times

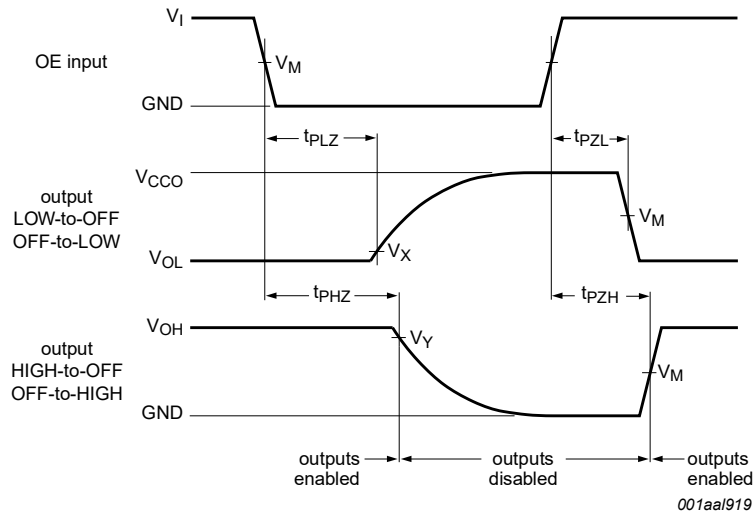

Measurement points are given in Table 13.

V_{OL} and V_{OH} are typical output voltage levels that occur with the output load.

Fig. 3. 3-state enable and disable times

Table 13. Measurement points [1]

Supply voltage	Input	Output		
V_{CCO}	V_M	V_M	V_X	V_Y
1.2 V	$0.5V_{CCI}$	$0.5V_{CCO}$	$V_{OL} + 0.1 V$	$V_{OH} - 0.1 V$
$1.5 V \pm 0.1 V$	$0.5V_{CCI}$	$0.5V_{CCO}$	$V_{OL} + 0.1 V$	$V_{OH} - 0.1 V$
$1.8 V \pm 0.15 V$	$0.5V_{CCI}$	$0.5V_{CCO}$	$V_{OL} + 0.15 V$	$V_{OH} - 0.15 V$
$2.5 V \pm 0.2 V$	$0.5V_{CCI}$	$0.5V_{CCO}$	$V_{OL} + 0.15 V$	$V_{OH} - 0.15 V$
$3.3 V \pm 0.3 V$	$0.5V_{CCI}$	$0.5V_{CCO}$	$V_{OL} + 0.3 V$	$V_{OH} - 0.3 V$
$5.0 V \pm 0.5 V$	$0.5V_{CCI}$	$0.5V_{CCO}$	$V_{OL} + 0.3 V$	$V_{OH} - 0.3 V$

[1] V_{CCI} is the supply voltage associated with the input and V_{CCO} is the supply voltage associated with the output.

Dual supply translating transceiver; auto direction sensing; 3-state

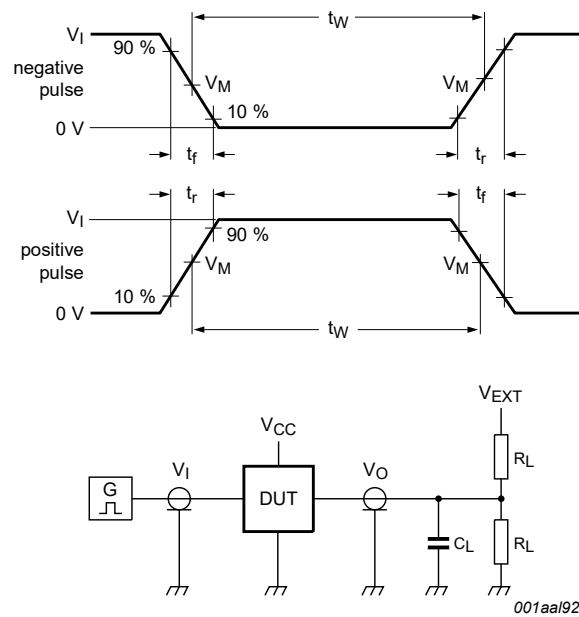

Test data is given in [Table 14](#).

All input pulses are supplied by generators having the following characteristics:

PRR ≤ 10 MHz; Z_O = 50 Ω; dV/dt ≥ 1.0 V/ns;

R_L = Load resistance;

C_L = Load capacitance including jig and probe capacitance;

V_{EXT} = External voltage for measuring switching times.

Fig. 4. Test circuit for measuring switching times

Table 14. Test data

Supply voltage		Input		Load		V _{EXT}		
V _{CC(A)}	V _{CC(B)}	V _I [1]	Δt/ΔV	C _L	R _L [2]	t _{PLH} , t _{PHL}	t _{PZH} , t _{PHZ}	t _{PZL} , t _{PLZ} [3]
1.2 V to 3.6 V	1.65 V to 5.5 V	V _{CCI}	≤ 1.0 ns/V	15 pF	50 kΩ, 1 MΩ	open	open	2V _{CCO}

[1] V_{CCI} is the supply voltage associated with the input.

[2] For measuring data rate, pulse width, propagation delay and output rise and fall measurements, R_L = 1 MΩ; for measuring enable and disable times, R_L = 50 kΩ.

[3] V_{CCO} is the supply voltage associated with the output.

11. Application information

11.1. Applications

Voltage level-translation applications. The NXB0106 can be used to interface between devices or systems operating at different supply voltages. See Fig. 5 for a typical operating circuit using the NXB0106.

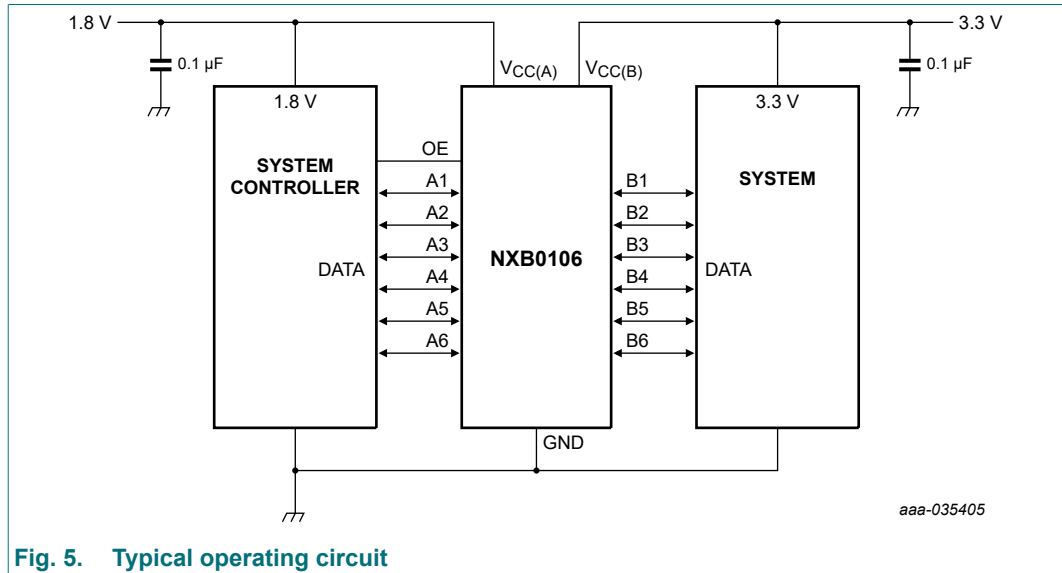

Fig. 5. Typical operating circuit

11.2. Architecture

The architecture of the NXB0106 is shown in Fig. 6. The device does not require an extra input signal to control the direction of data flow from A to B or from B to A. In a static state, the output drivers of the NXB0106 can maintain a defined output level, but the output architecture is designed to be weak, so that they can be overdriven by an external driver when data on the bus starts flowing in the opposite direction. The output one shots detect rising or falling edges on the A or B ports. During a rising edge, the one shots turn on the PMOS transistors (T1, T3) for a short duration, accelerating the low-to-high transition. Similarly, during a falling edge, the one shots turn on the NMOS transistors (T2, T4) for a short duration, accelerating the high-to-low transition. During output transitions the typical output impedance is 70 Ω at $V_{CCO} = 1.2\text{ V to }1.8\text{ V}$, 50 Ω at $V_{CCO} = 1.8\text{ V to }3.3\text{ V}$ and 40 Ω at $V_{CCO} = 3.3\text{ V to }5.0\text{ V}$.

Dual supply translating transceiver; auto direction sensing; 3-state

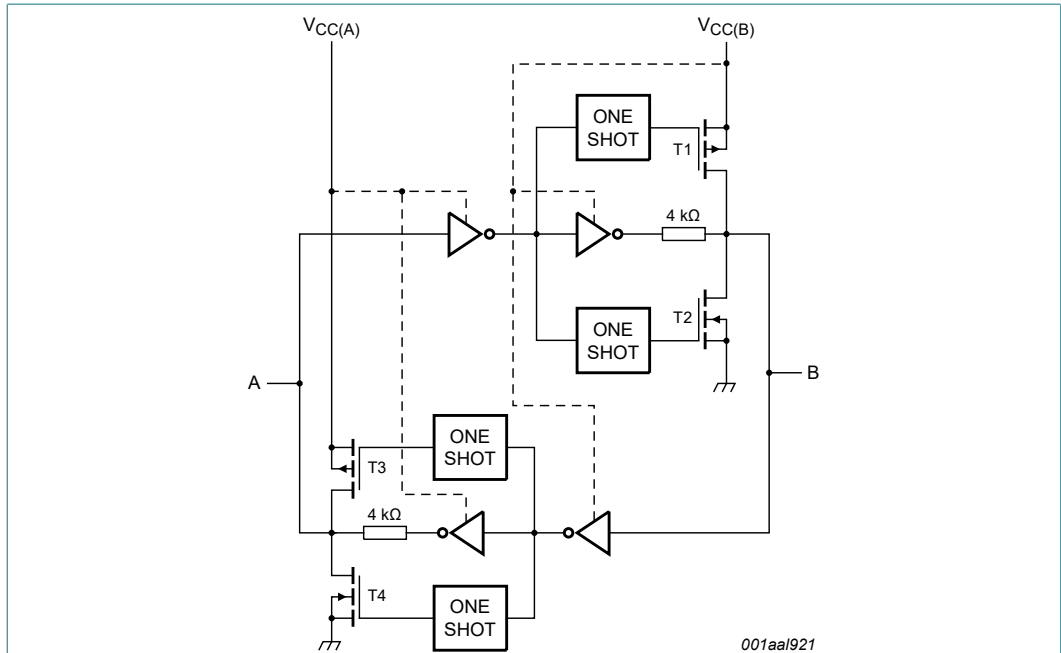
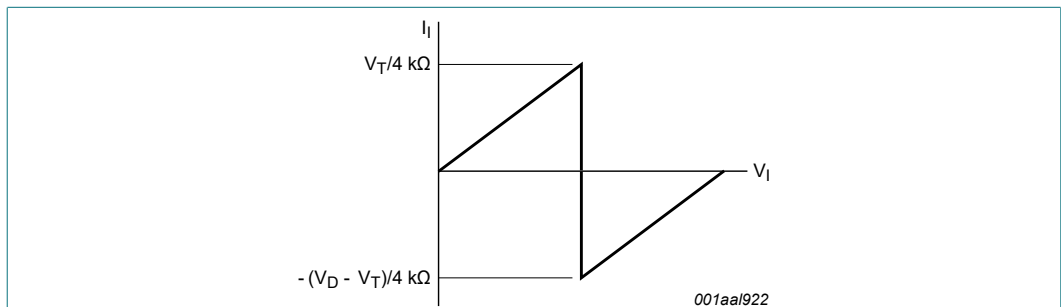

Fig. 6. Architecture of NXB0106 I/O cell (one channel)

11.3. Input driver requirements

For correct operation, the device driving the data I/Os of the NXB0106 must have a minimum drive capability of ± 2 mA. See Fig. 7 for a plot of typical input current versus input voltage.



V_T : input threshold voltage of the NXB0106 (typically $V_{CC1} / 2$).
 V_D : supply voltage of the external driver.

Fig. 7. Typical input current versus input voltage graph

11.4. Power up

During operation $V_{CC(A)}$ must never be higher than $V_{CC(B)}$, however during power-up $V_{CC(A)} \geq V_{CC(B)}$ does not damage the device, so either power supply can be ramped up first. There is no special power-up sequencing required. The NXB0106 includes circuitry that disables all output ports when either $V_{CC(A)}$ or $V_{CC(B)}$ is switched off.

11.5. Enable and disable

An output enable input (OE) is used to disable the device. Setting OE = LOW causes all I/Os to assume the high-impedance OFF-state. The disable time (t_{dis} with no external load) indicates the delay between when OE goes LOW and when outputs actually become disabled. The enable time (t_{en}) indicates the amount of time the user must allow for one one-shot circuitry to become operational after OE is taken HIGH. To ensure the high-impedance OFF-state during power-up or power-down, pin OE should be tied to GND through a pull-down resistor, the minimum value of the resistor is determined by the current-sourcing capability of the driver.

11.6. Pull-up or pull-down resistors on I/O lines

As mentioned previously the NXB0106 is designed with low static drive strength to drive capacitive loads of up to 70 pF. To avoid output contention issues, any pull-up or pull-down resistors used must be kept higher than 50 k Ω . For this reason the NXB0106 is not recommended for use in open drain driver applications such as 1-Wire or I²C. For these applications, the NXS0106 level translator is recommended.

12. Package outline

TSSOP16: plastic thin shrink small outline package; 16 leads; body width 4.4 mm

SOT403-1

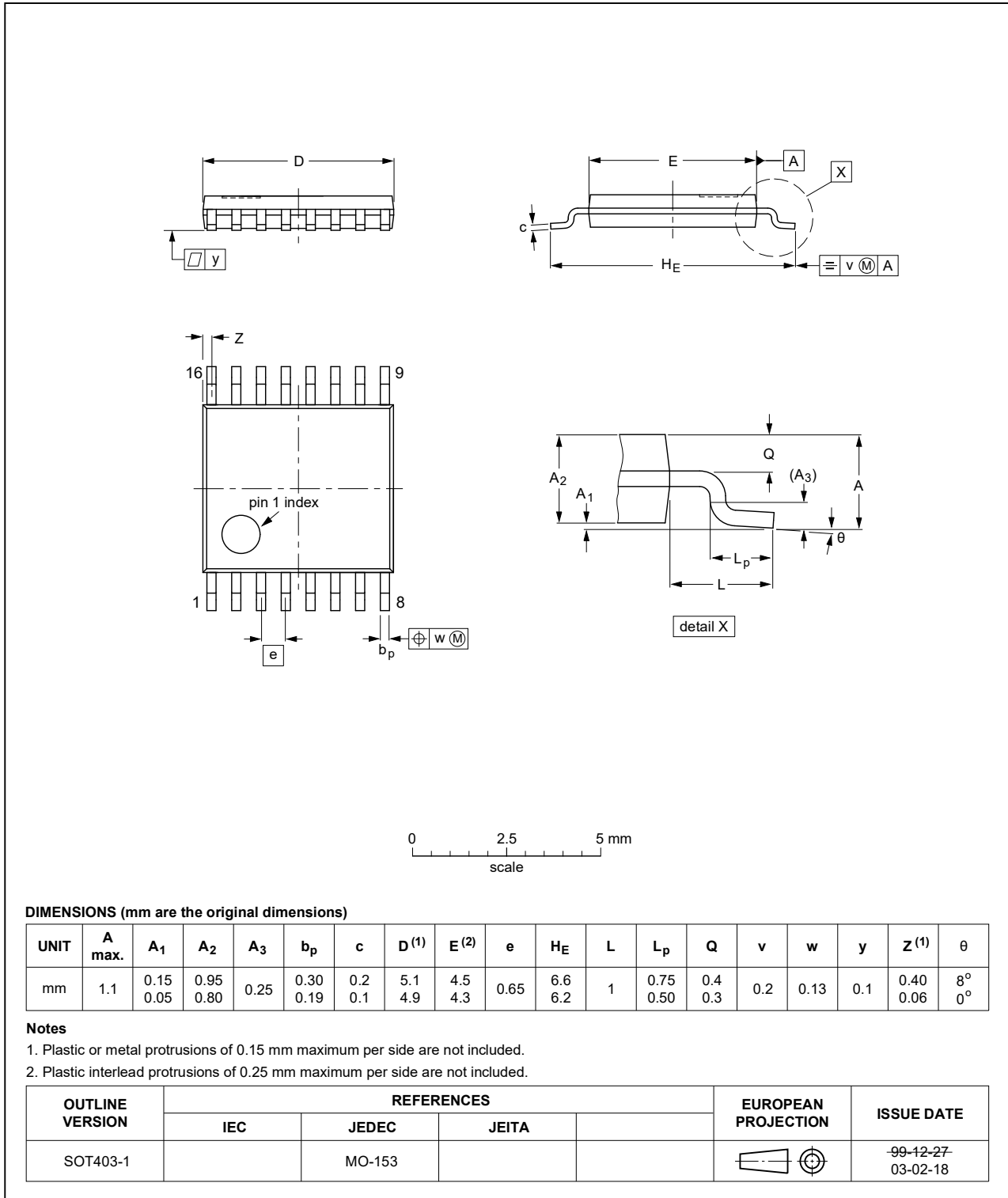

Fig. 8. Package outline SOT403-1 (TSSOP16)

DHVQFN16: plastic dual in-line compatible thermal enhanced very thin quad flat package; no leads; 16 terminals; body 2.5 x 3.5 x 0.85 mm

SOT763-1

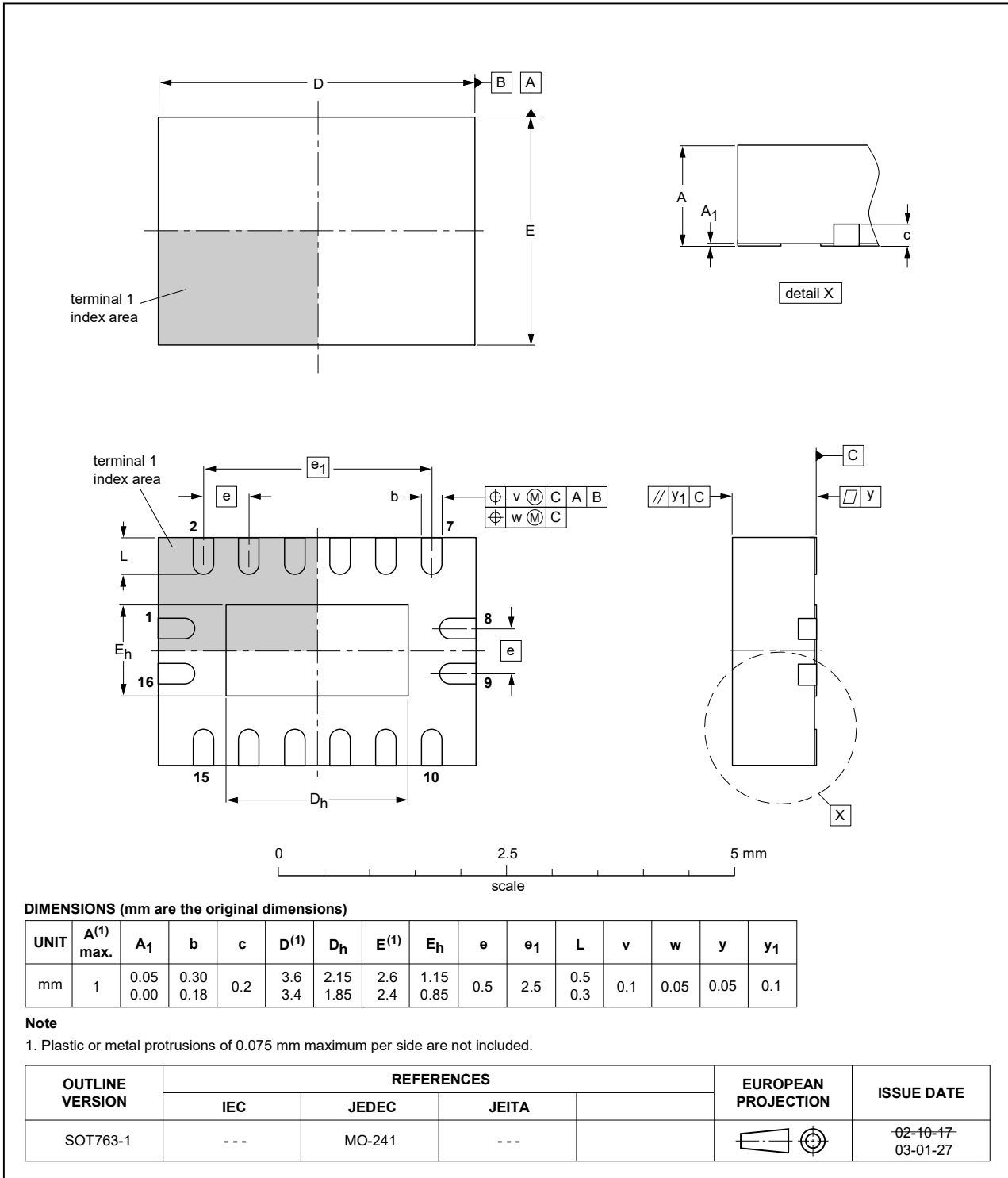

Fig. 9. Package outline SOT763-1 (DHVQFN16)

13. Abbreviations

Table 15. Abbreviations

Acronym	Description
CDM	Charged Device Model
CMOS	Complementary Metal Oxide Semiconductor
DUT	Device Under Test
ESD	Electro Static Discharge
HBM	Human Body Model
MM	Machine Model

14. Revision history

Table 16. Revision history

Document ID	Release date	Data sheet status	Change notice	Supersedes
NXB0106 v.1	20230802	Product data sheet	-	-

15. Legal information

Data sheet status

Document status [1][2]	Product status [3]	Definition
Objective [short] data sheet	Development	This document contains data from the objective specification for product development.
Preliminary [short] data sheet	Qualification	This document contains data from the preliminary specification.
Product [short] data sheet	Production	This document contains the product specification.

- [1] Please consult the most recently issued document before initiating or completing a design.
- [2] The term 'short data sheet' is explained in section "Definitions".
- [3] The product status of device(s) described in this document may have changed since this document was published and may differ in case of multiple devices. The latest product status information is available on the internet at <https://www.nexperia.com>.

Definitions

Draft — The document is a draft version only. The content is still under internal review and subject to formal approval, which may result in modifications or additions. Nexperia does not give any representations or warranties as to the accuracy or completeness of information included herein and shall have no liability for the consequences of use of such information.

Short data sheet — A short data sheet is an extract from a full data sheet with the same product type number(s) and title. A short data sheet is intended for quick reference only and should not be relied upon to contain detailed and full information. For detailed and full information see the relevant full data sheet, which is available on request via the local Nexperia sales office. In case of any inconsistency or conflict with the short data sheet, the full data sheet shall prevail.

Product specification — The information and data provided in a Product data sheet shall define the specification of the product as agreed between Nexperia and its customer, unless Nexperia and customer have explicitly agreed otherwise in writing. In no event however, shall an agreement be valid in which the Nexperia product is deemed to offer functions and qualities beyond those described in the Product data sheet.

Disclaimers

Limited warranty and liability — Information in this document is believed to be accurate and reliable. However, Nexperia does not give any representations or warranties, expressed or implied, as to the accuracy or completeness of such information and shall have no liability for the consequences of use of such information. Nexperia takes no responsibility for the content in this document if provided by an information source outside of Nexperia.

In no event shall Nexperia be liable for any indirect, incidental, punitive, special or consequential damages (including - without limitation - lost profits, lost savings, business interruption, costs related to the removal or replacement of any products or rework charges) whether or not such damages are based on tort (including negligence), warranty, breach of contract or any other legal theory.

Notwithstanding any damages that customer might incur for any reason whatsoever, Nexperia's aggregate and cumulative liability towards customer for the products described herein shall be limited in accordance with the Terms and conditions of commercial sale of Nexperia.

Right to make changes — Nexperia reserves the right to make changes to information published in this document, including without limitation specifications and product descriptions, at any time and without notice. This document supersedes and replaces all information supplied prior to the publication hereof.

Suitability for use — Nexperia products are not designed, authorized or warranted to be suitable for use in life support, life-critical or safety-critical systems or equipment, nor in applications where failure or malfunction of an Nexperia product can reasonably be expected to result in personal

injury, death or severe property or environmental damage. Nexperia and its suppliers accept no liability for inclusion and/or use of Nexperia products in such equipment or applications and therefore such inclusion and/or use is at the customer's own risk.

Quick reference data — The Quick reference data is an extract of the product data given in the Limiting values and Characteristics sections of this document, and as such is not complete, exhaustive or legally binding.

Applications — Applications that are described herein for any of these products are for illustrative purposes only. Nexperia makes no representation or warranty that such applications will be suitable for the specified use without further testing or modification.

Customers are responsible for the design and operation of their applications and products using Nexperia products, and Nexperia accepts no liability for any assistance with applications or customer product design. It is customer's sole responsibility to determine whether the Nexperia product is suitable and fit for the customer's applications and products planned, as well as for the planned application and use of customer's third party customer(s). Customers should provide appropriate design and operating safeguards to minimize the risks associated with their applications and products.

Nexperia does not accept any liability related to any default, damage, costs or problem which is based on any weakness or default in the customer's applications or products, or the application or use by customer's third party customer(s). Customer is responsible for doing all necessary testing for the customer's applications and products using Nexperia products in order to avoid a default of the applications and the products or of the application or use by customer's third party customer(s). Nexperia does not accept any liability in this respect.

Limiting values — Stress above one or more limiting values (as defined in the Absolute Maximum Ratings System of IEC 60134) will cause permanent damage to the device. Limiting values are stress ratings only and (proper) operation of the device at these or any other conditions above those given in the Recommended operating conditions section (if present) or the Characteristics sections of this document is not warranted. Constant or repeated exposure to limiting values will permanently and irreversibly affect the quality and reliability of the device.

Terms and conditions of commercial sale — Nexperia products are sold subject to the general terms and conditions of commercial sale, as published at <http://www.nexperia.com/profile/terms>, unless otherwise agreed in a valid written individual agreement. In case an individual agreement is concluded only the terms and conditions of the respective agreement shall apply. Nexperia hereby expressly objects to applying the customer's general terms and conditions with regard to the purchase of Nexperia products by customer.

No offer to sell or license — Nothing in this document may be interpreted or construed as an offer to sell products that is open for acceptance or the grant, conveyance or implication of any license under any copyrights, patents or other industrial or intellectual property rights.

Export control — This document as well as the item(s) described herein may be subject to export control regulations. Export might require a prior authorization from competent authorities.

Non-automotive qualified products — Unless this data sheet expressly states that this specific Nexperia product is automotive qualified, the product is not suitable for automotive use. It is neither qualified nor tested in accordance with automotive testing or application requirements. Nexperia accepts no liability for inclusion and/or use of non-automotive qualified products in automotive equipment or applications.

In the event that customer uses the product for design-in and use in automotive applications to automotive specifications and standards, customer (a) shall use the product without Nexperia's warranty of the product for such automotive applications, use and specifications, and (b) whenever customer uses the product for automotive applications beyond Nexperia's specifications such use shall be solely at customer's own risk, and (c) customer fully indemnifies Nexperia for any liability, damages or failed product claims resulting from customer design and use of the product for automotive applications beyond Nexperia's standard warranty and Nexperia's product specifications.

Translations — A non-English (translated) version of a document is for reference only. The English version shall prevail in case of any discrepancy between the translated and English versions.

Trademarks

Notice: All referenced brands, product names, service names and trademarks are the property of their respective owners.

Contents

1. General description	1
2. Features and benefits	1
3. Ordering information	1
4. Functional diagram	2
5. Pinning information	2
5.1. Pinning.....	2
5.2. Pin description.....	3
6. Functional description	3
7. Limiting values	3
8. Recommended operating conditions	4
9. Static characteristics	4
10. Dynamic characteristics	7
10.1. Waveforms and test circuit.....	12
11. Application information	14
11.1. Applications.....	14
11.2. Architecture.....	14
11.3. Input driver requirements.....	15
11.4. Power up.....	15
11.5. Enable and disable.....	16
11.6. Pull-up or pull-down resistors on I/O lines.....	16
12. Package outline	17
13. Abbreviations	19
14. Revision history	19
15. Legal information	20

© Nexperia B.V. 2023. All rights reserved

For more information, please visit: <http://www.nexperia.com>

For sales office addresses, please send an email to: salesaddresses@nexperia.com

Date of release: 2 August 2023