

# MOSFET - N-Channel Silicon Carbide

## 650 V, 25.2 mΩ, 108 A

### Product Preview

## NTHL025N065SC1



ON Semiconductor®

[www.onsemi.com](http://www.onsemi.com)

#### MAXIMUM RATINGS

Parameter	Symbol	Value	Unit
Drain-to-Source Voltage	$V_{DSS}$	650	V
Gate-to-Source Voltage	$V_{GS}$	+23/-10	V
Continuous Drain Current $R_{\theta JC}$	$T_C = 25^\circ\text{C}$	$I_{DC}$	108 A
Power Dissipation $R_{\theta JC}$		$P_{DC}$	528 W
Continuous Drain Current $R_{\theta JC}$	$T_C = 100^\circ\text{C}$	$I_{DC}$	84.8 A
Power Dissipation $R_{\theta JC}$		$P_{DC}$	264 W
Continuous Drain Current $R_{\theta JA}$	$T_A = 25^\circ\text{C}$	$I_{DA}$	TBD A
Power Dissipation $R_{\theta JA}$		$P_{DA}$	TBD W
Continuous Drain Current $R_{\theta JA}$	$T_A = 100^\circ\text{C}$	$I_{DA}$	TBD A
Power Dissipation $R_{\theta JA}$		$P_{DA}$	TBD W
Pulsed Drain Current $R_{\theta JC}$	$T_C = 25^\circ\text{C}$ , $t_P = 10 \mu\text{s}$	$I_{DM}$	514 A
Operating Junction and Storage Temperature Range	$T_J, T_{stg}$	-55 to +175	$^\circ\text{C}$
Source Current (Body Diode)	$I_S$	118	A
Single Pulse Drain-to-Source Avalanche Energy ( $T_J = 25^\circ\text{C}$ , $V_{GS} = 18 \text{ V}$ , $I_{L(pk)} = 1 \text{ A}$ , $L = 0.1 \text{ mH}$ , $R_G = 25 \Omega$ )	$E_{AS}$	TBD	mJ
Lead Temperature for Soldering Purposes	$T_L$	TBD	$^\circ\text{C}$

Stresses exceeding those listed in the Maximum Ratings table may damage the device. If any of these limits are exceeded, device functionality should not be assumed, damage may occur and reliability may be affected.

#### THERMAL RESISTANCE

Parameter	Symbol	Value	Unit
Junction-to-Case (Note 1)	$R_{\theta JC}$	0.284	$^\circ\text{C}/\text{W}$
Junction-to-Ambient (Note 1)	$R_{\theta JA}$	TBD	

- The entire application environment impacts the thermal resistance values shown, they are not constants and are only valid for the particular conditions noted.

This document contains information on a product under development. ON Semiconductor reserves the right to change or discontinue this product without notice.

$V_{(BR)DSS}$	$R_{DS(on)}$ TYP	$I_D$ MAX
650 V	25.2 mΩ @ $V_{GS} = 18 \text{ V}$	108 A

#### N-CHANNEL MOSFET

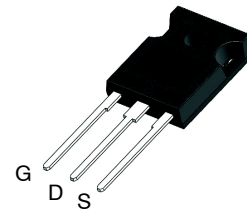
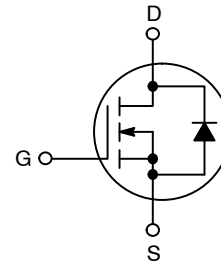

TO-247-3LD  
CASE 340CH

#### MARKING DIAGRAM



&Z = Assembly Plant Code  
 &3 = Date Code (Year & Week)  
 &K = Lot  
 NTHL025N065SC1 = Specific Device Code

#### ORDERING INFORMATION

See detailed ordering and shipping information on page 2 of this data sheet.

# NTHL025N065SC1

## ELECTRICAL CHARACTERISTICS

Parameter	Symbol	Test Conditions	Min	Typ	Max	Unit
-----------	--------	-----------------	-----	-----	-----	------

### OFF CHARACTERISTICS

Drain-to-Source Breakdown Voltage	$V_{(BR)DSS}$	$V_{GS} = 0\text{ V}, I_D = 2.50\text{e} - 04\text{A}, T_C = 25^\circ\text{C}$	650			V
Drain-to-Source Breakdown Voltage Temperature Coefficient	$V_{(BR)DSS}/T_J$	$V_{GS} = 0\text{ V}, I_D = 2.50\text{e} - 04\text{A}, T_{Jmax} = 175^\circ\text{C}$		-0.012		V/°C
Zero Gate Voltage Drain Current	$I_{DSS}$	$V_{DS} = 650\text{ V}, T_C = 25^\circ\text{C}$			100	$\mu\text{A}$
		$V_{DS} = 650\text{ V}, T_C = 175^\circ\text{C}$			1	mA
Gate-to-Source Leakage Current	$I_{GSS}$	$V_{GS} = +18/-8\text{ V}, V_{DS} = 0\text{ V}$			$\pm 1$	$\mu\text{A}$

### ON CHARACTERISTICS

Drain-to-Source On Resistance	$R_{DS(on)}$	$V_G = 18\text{ V}, I_D = 48\text{ A}, T_C = 25^\circ\text{C}$		25.24		m $\Omega$
		$V_G = 18\text{ V}, I_D = 48\text{ A}, T_C = 175^\circ\text{C}$		29.58		
Gate Threshold Voltage	$V_{GS(th)}$	$V_G = V_D, I_D = 9.58 - 03\text{A}$		3.19		V
Gate Threshold Voltage Temperature Coefficient	$V_{GS(th)}/T_J$			-6.42		mV/°C
Forward Transconductance	$g_{FS}$	$V_D = 10\text{ V}, I_D = 48\text{ A}$		23.97		S

### CHARGES, CAPACITANCES & GATE RESISTANCE

Gate Resistance	$R_G$	$V_D = 325\text{ V}, V_G = 0\text{ V}, f = 1\text{e}6$		1.33		$\Omega$	
Input Capacitance	$C_{ISS}$			3479			pF
Output Capacitance	$C_{OSS}$			265			
Reverse Transfer Capacitance	$C_{RSS}$			25.11			
Effective Output Capacitance	$C_{OSSef}$	$V_{DS} = 0\text{ to }325\text{ V}, V_G = 0\text{ V}, f = 1\text{e}6$		512			
Energy Related Output Capacitance	$C_{OSSer}$			348			
Coss Stored Energy	$E_{OSS}$			18.38			$\mu\text{J}$
Total Gate Charge	$Q_{G(tot)}$	$V_D = 520\text{ V}, I_D = 48\text{ A}, V_G = -5/18\text{ V}$		155		nC	
Gate-to-Source Charge	$Q_{GS}$			52.3			
Gate-to-Drain Charge	$Q_{GD}$			48.62			

### SWITCHING CHARACTERISTICS

Turn-On Delay Time	$t_{d(on)}$	$V_{GS} = -5/18\text{ V}, V_D = 520\text{ V}, I_D = 48\text{ A}, R_G = 6\ \Omega$		62.4		ns
Turn-Off Delay Time	$t_{d(off)}$			43.85		
Rise Time	$t_r$			11.93		
Fall Time	$t_f$			11.74		
Turn-On Switching Loss	$E_{ON}$			1.03		mJ
Turn-Off Switching Loss	$E_{OFF}$			0.208		
Total Switching Loss	$E_{TOT}$			1.24		

### SOURCE-TO-DRAIN DIODE CHARACTERISTICS

Forward Diode Voltage	$V_{SD}$	$V_{GS} = -5\text{ V}, I_D = 48\text{ A}, T_C = 25^\circ\text{C}$		4.53		V
		$V_{GS} = -5\text{ V}, I_D = 48\text{ A}, T_C = 175^\circ\text{C}$		4.13		
Reverse Recovery Time	$t_{RR}$	$V_{GS} = -5\text{ V}, I_S = 48\text{ A}, dl/dt = 1000\text{ A}/\mu\text{s}, V_{DS} = 520\text{ V}$		40.34		ns
Reverse Recovery Charge	$Q_{RR}$			359		nC
Reverse Recovery Energy	$E_{REC}$			42.14		$\mu\text{J}$
Peak Reverse Recovery Current	$I_{RRM}$			14.30		A

Product parametric performance is indicated in the Electrical Characteristics for the listed test conditions, unless otherwise noted. Product performance may not be indicated by the Electrical Characteristics if operated under different conditions.

# NTHL025N065SC1

## TYPICAL CHARACTERISTICS

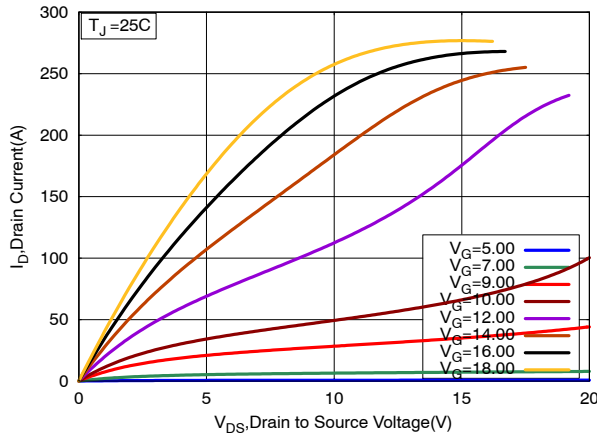

Figure 1. On-Region Characteristics

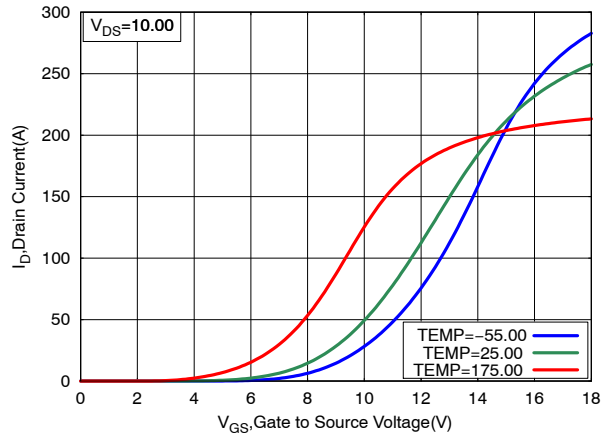

Figure 2. Transfer Characteristics

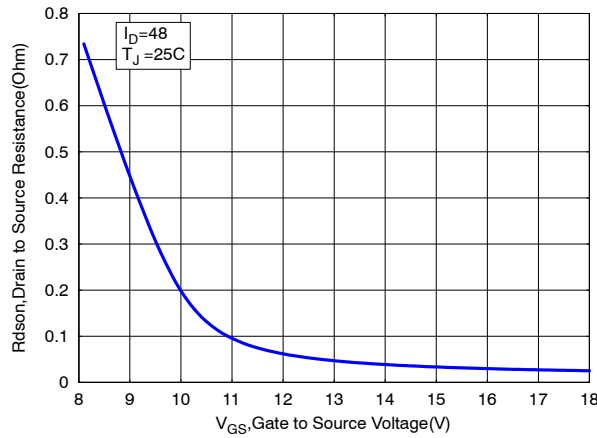

Figure 3. On-Resistance vs. VGS

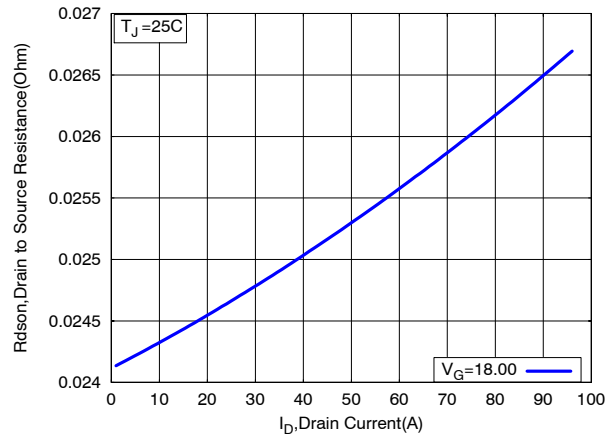

Figure 4. On-Resistance vs. Drain Current and Gate Voltage

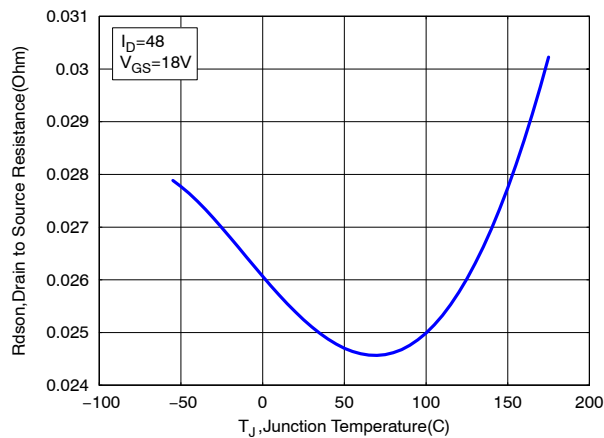

Figure 5. On-Resistance Variation with Temperature

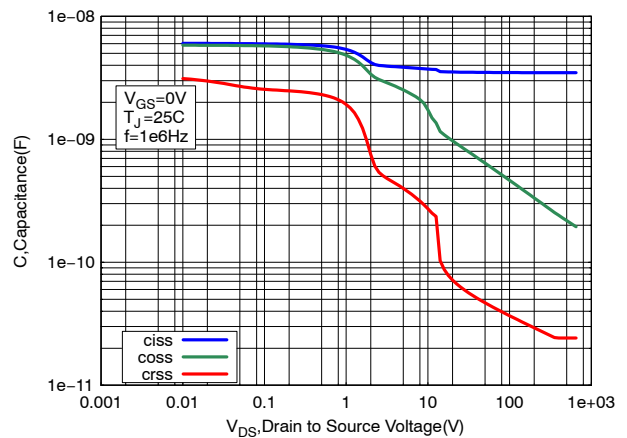

Figure 6. Capacitance Variation

# NTHL025N065SC1

## TYPICAL CHARACTERISTICS

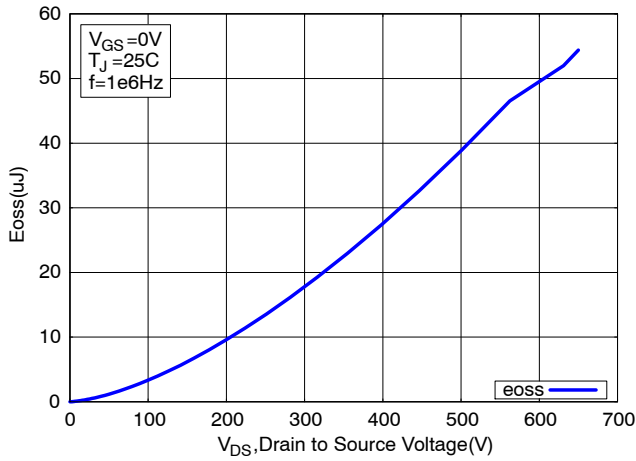

Figure 7. Eoss vs. Drain-to-Source Voltage

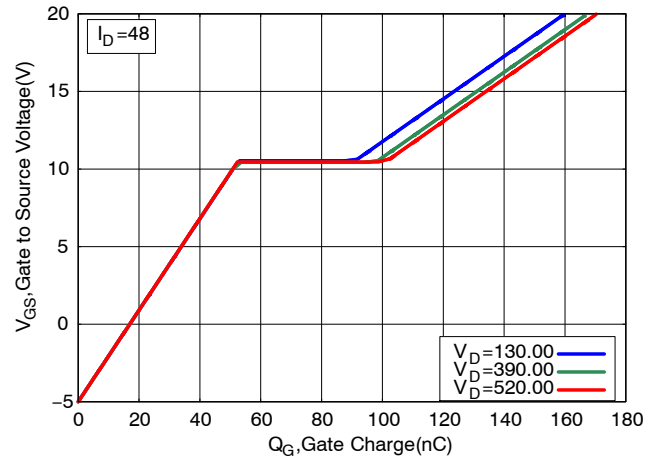

Figure 8. Gate-to-Source Voltage vs. Total Charge

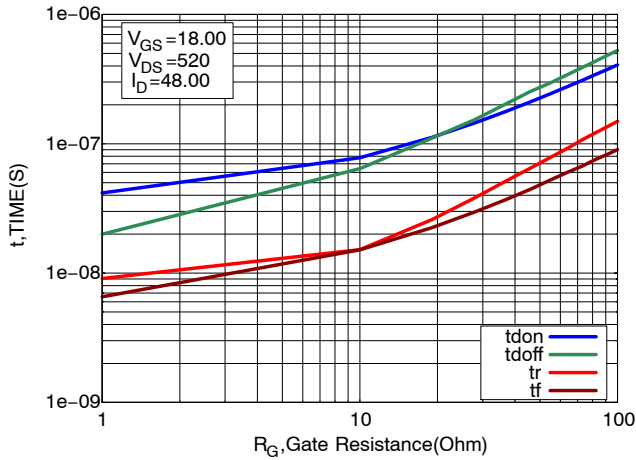

Figure 9. Resistive Switching Time Variation vs. Gate Resistance

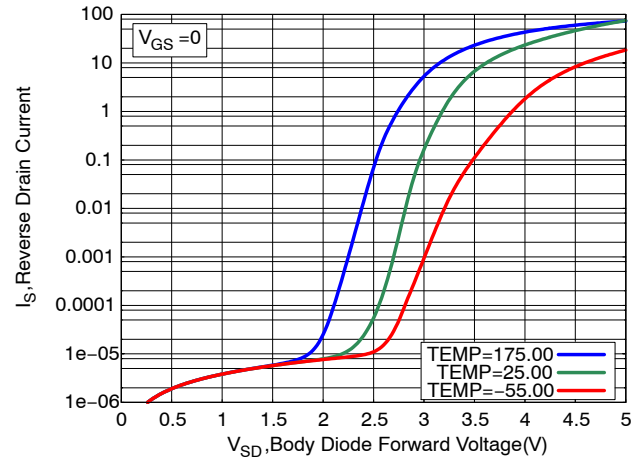

Figure 10. Diode Forward Voltage vs. Current

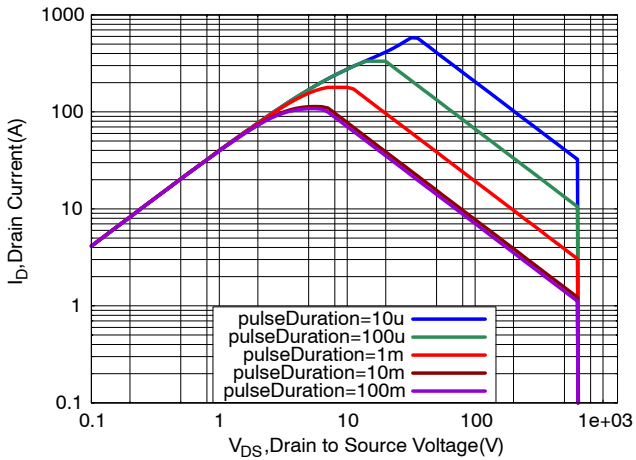

Figure 11. Maximum Rated Forward Biased Safe Operating Area

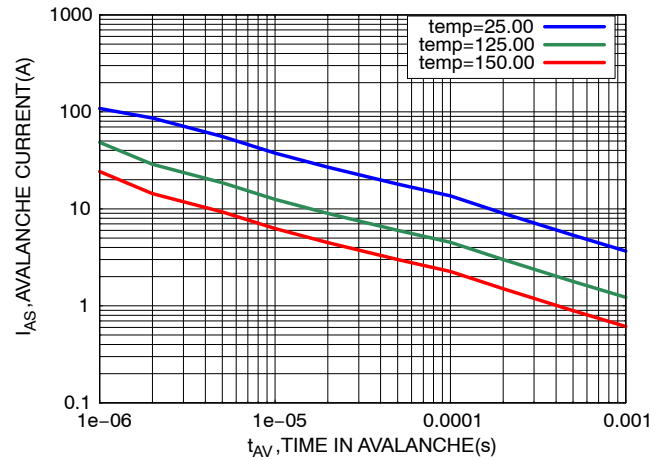

Figure 12. Ipeak vs. Time in Avalanche

# NTHL025N065SC1

## TYPICAL CHARACTERISTICS

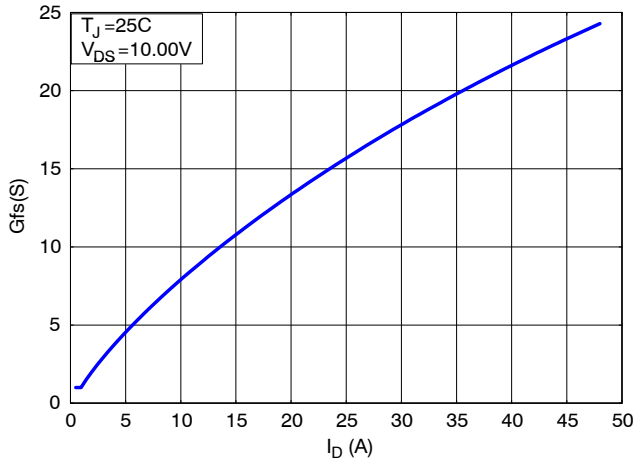

Figure 13. GFS vs. ID

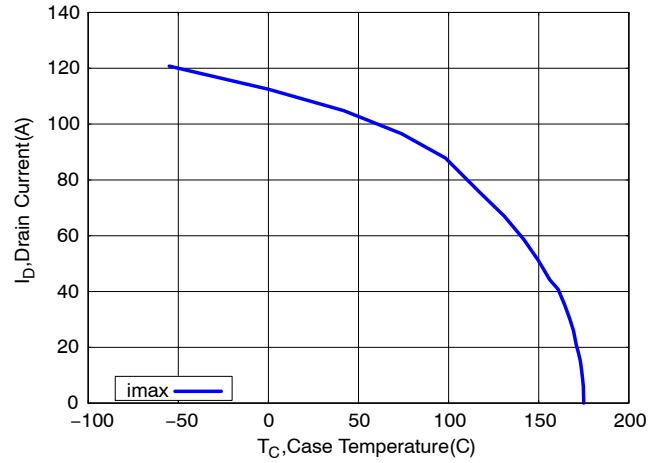

Figure 14. Maximum Current vs. Case Temperature

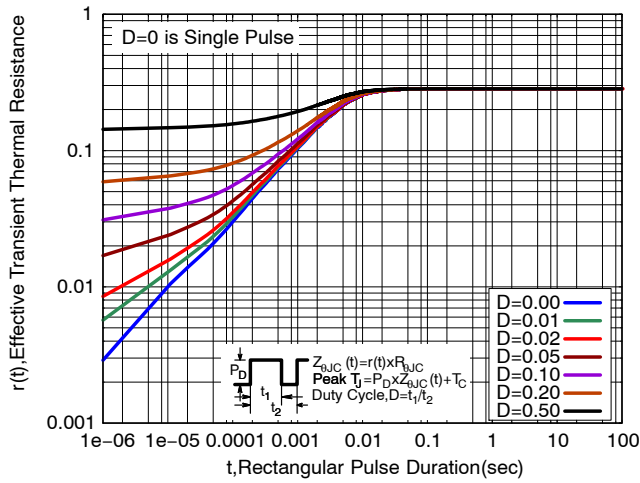

Figure 15. Thermal Response

### PACKAGE MARKING AND ORDERING INFORMATION

Part Number	Top Marking	Package	Packing Method	Reel Size	Tape Width	Quantity
NTHL025N065SC1	NTHL025N065SC1	TO-247 Long Lead	Tube	N/A	N/A	30 Units

# NTHL025N065SC1

## PACKAGE DIMENSIONS

TO-247-3LD  
CASE 340CH  
ISSUE A

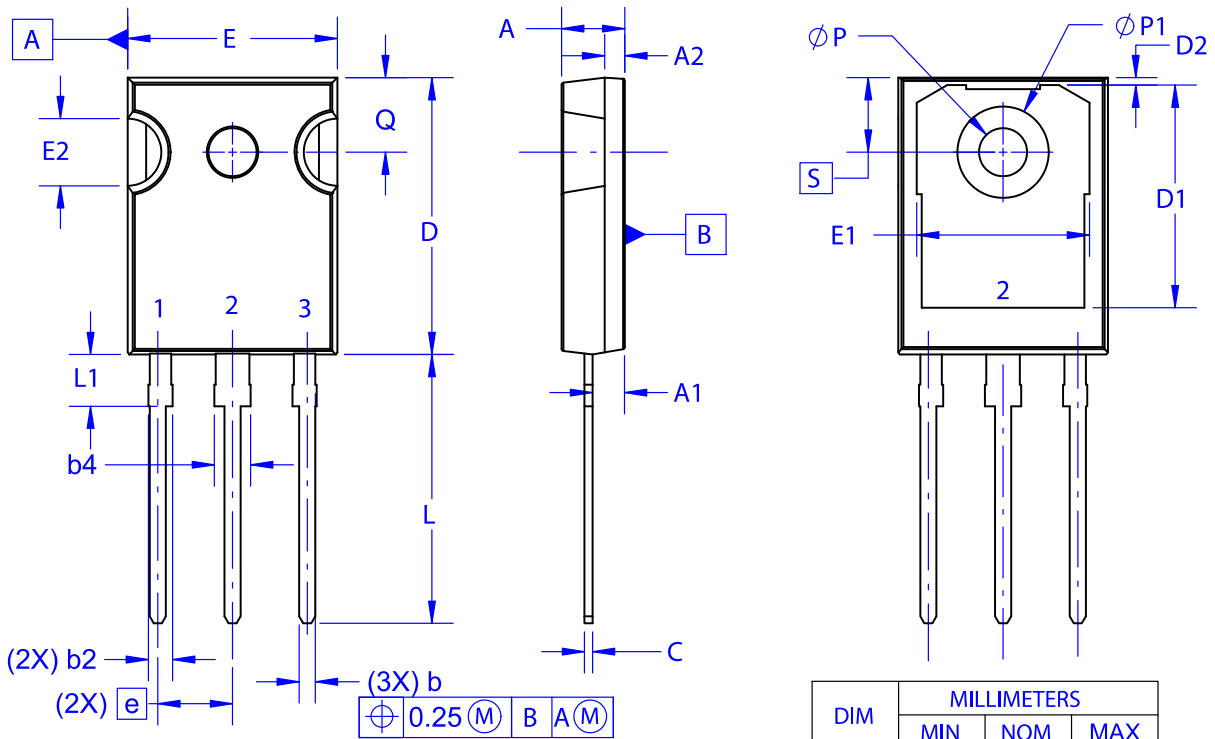

NOTES: UNLESS OTHERWISE SPECIFIED.

- A. DIMENSIONS ARE EXCLUSIVE OF BURRS, MOLD FLASH, AND TIE BAR EXTRUSIONS.
- B. ALL DIMENSIONS ARE IN MILLIMETERS.
- C. DRAWING CONFORMS TO ASME Y14.5 - 2009.
- D. DIMENSION A1 TO BE MEASURED IN THE REGION DEFINED BY L1.
- E. LEAD FINISH IS UNCONTROLLED IN THE REGION DEFINED BY L1.

DIM	MILLIMETERS		
	MIN	NOM	MAX
A	4.58	4.70	4.82
A1	2.29	2.475	2.66
A2	1.40	1.50	1.60
D	20.32	20.57	20.82
E	15.37	15.62	15.87
E2	4.96	5.08	5.20
e	~	5.56	~
L	19.75	20.00	20.25
L1	3.69	3.81	3.93
ØP	3.51	3.58	3.65
Q	5.34	5.46	5.58
S	5.34	5.46	5.58
b	1.17	1.26	1.35
b2	1.53	1.65	1.77
b4	2.42	2.54	2.66
c	0.51	0.61	0.71
D1	13.08	~	~
D2	0.51	0.93	1.35
E1	12.81	~	~
ØP1	6.61	6.73	6.85

ON Semiconductor and  are trademarks of Semiconductor Components Industries, LLC dba ON Semiconductor or its subsidiaries in the United States and/or other countries. ON Semiconductor owns the rights to a number of patents, trademarks, copyrights, trade secrets, and other intellectual property. A listing of ON Semiconductor's product/patent coverage may be accessed at [www.onsemi.com/site/pdf/Patent-Marking.pdf](http://www.onsemi.com/site/pdf/Patent-Marking.pdf). ON Semiconductor reserves the right to make changes without further notice to any products herein. ON Semiconductor makes no warranty, representation or guarantee regarding the suitability of its products for any particular purpose, nor does ON Semiconductor assume any liability arising out of the application or use of any product or circuit, and specifically disclaims any and all liability, including without limitation special, consequential or incidental damages. Buyer is responsible for its products and applications using ON Semiconductor products, including compliance with all laws, regulations and safety requirements or standards, regardless of any support or applications information provided by ON Semiconductor. "Typical" parameters which may be provided in ON Semiconductor data sheets and/or specifications can and do vary in different applications and actual performance may vary over time. All operating parameters, including "Typicals" must be validated for each customer application by customer's technical experts. ON Semiconductor does not convey any license under its patent rights nor the rights of others. ON Semiconductor products are not designed, intended, or authorized for use as a critical component in life support systems or any FDA Class 3 medical devices or medical devices with a same or similar classification in a foreign jurisdiction or any devices intended for implantation in the human body. Should Buyer purchase or use ON Semiconductor products for any such unintended or unauthorized application, Buyer shall indemnify and hold ON Semiconductor and its officers, employees, subsidiaries, affiliates, and distributors harmless against all claims, costs, damages, and expenses, and reasonable attorney fees arising out of, directly or indirectly, any claim of personal injury or death associated with such unintended or unauthorized use, even if such claim alleges that ON Semiconductor was negligent regarding the design or manufacture of the part. ON Semiconductor is an Equal Opportunity/Affirmative Action Employer. This literature is subject to all applicable copyright laws and is not for resale in any manner.

## PUBLICATION ORDERING INFORMATION

### LITERATURE FULFILLMENT:

Email Requests to: [orderlit@onsemi.com](mailto:orderlit@onsemi.com)

ON Semiconductor Website: [www.onsemi.com](http://www.onsemi.com)

### TECHNICAL SUPPORT

North American Technical Support:  
Voice Mail: 1 800-282-9855 Toll Free USA/Canada  
Phone: 011 421 33 790 2910

Europe, Middle East and Africa Technical Support:

Phone: 00421 33 790 2910

For additional information, please contact your local Sales Representative