

NTC Thermistors, Flex Foil Sensors



LINKS TO ADDITIONAL RESOURCES



- NTC curve computation:
www.vishay.com/thermistors/ntc-curve-list/

QUICK REFERENCE DATA		
PARAMETER	VALUE	UNIT
Resistance value at 25 °C	10K to 122K	Ω
Tolerance on R_{25} -value	± 1; ± 2; ± 3	%
$B_{25/85}$ -value	3435 to 3960	K
Tolerance on $B_{25/85}$ -value	± 1	%
Operating temperature range at zero power	-40 to +125	°C
Thermal time constant by heating ^{(1) (3)}	2	s
Thermal gradient ⁽³⁾	< 0.02	K/K
Minimum dielectric withstanding voltage ⁽²⁾	500	V _{AC}
Minimum insulation resistance	10	MΩ
Maximum dissipation at 25 °C	60	mW
Weight (without connector)	0.06	g

Notes

- (1) Measured from 25 °C air to 125 °C heated plate, pressed on the surface
- (2) Withstanding voltage up to 4 kV_{AC} between the NTC and the bottom stiffener
- (3) Thermal time constant and thermal gradient are dependent on the way of mounting

FEATURES

- Rapid response time on surface down to 2 s
- Suitable for narrow space applications
- High flexibility of the foil
- Insulated and humidity resistant
- A strain relief hole is included in the flex design to avoid traction to the sensor head
- Gold plated terminations
- AEC-Q200 qualified
- Material categorization: for definitions of compliance please see www.vishay.com/doc?99912

RoHS
COMPLIANT

APPLICATIONS

- Consumer appliances and white goods
- Power supply (heat-sinks)
- Battery, displays, LED
- Industrial applications, robotics
- Boilers
- EV and HV batteries

DESCRIPTION

- Miniature NTC thermistor body mounted on an insulated flex foil and topped with an insulating epoxy glob top
- For flat surface temperature sensing with low thermal mass and rapid response time

MOUNTING

- The stiff flat sensing area can be pressed against a flat surface by means of insulating material (silicone foam), by spring force or by taping it with a double sided temperature resistant adhesive
- The sensor contacts can be connected to a PCB counter-connector or wire-to-wire connector or soldered to conductors, or crimped with FFC connectors and ZIF connectors
- A mating connector can be for example a 0.5 mm pitch 7 poles connector for FPC, with top contacts, accepting 4 mm FPC width, ZIF or non-ZIF versions. The poles (1 + 2) and (6 + 7) can be used for the electrical connection. For example in SMT versions: TE 1734839-7, Molex 054550-0771, Molex 052745-0797
- Consult Vishay for other screw sizes, lead length, insulation, connector crimping or other features

Note

- FFC/FPC = Flexible Film Circuit/Flexible Printed Circuit

ELECTRICAL DATA AND ORDERING INFORMATION					
R_{25} (Ω)	R_{25} -TOL. (± %)	$B_{25/85}$ (K)	$B_{25/85}$ -TOL (± %)	DESCRIPTION	SAP MATERIAL AND ORDERING NUMBER
10 000	2	3435	1	NTC Flex05 10K 2 % 3435K 25 mm	NTCAFLEX05103GL
10 000	3	3960	1	NTC Flex05 10K 3 % 3960K 25 mm	NTCAFLEX05103HH
47 000	3	3960	1	NTC Flex05 47K 3 % 3960K 25 mm	NTCAFLEX05473HH
122 000	1	3590	1	NTC Flex05 122K 1 % 3590 K 25 mm	NTCAFLEX05124FM

SAP CODIFICATION																
Part Number: NTCAFLEX05473HH																
	N	T	C	A	F	L	E	X	0	5	4	7	3	H	H	
MODEL	ASSEMBLY	FLEX SENSOR	MECHANICAL EXECUTION	RESISTANCE VALUE		TOLERANCE ON R_{25}		B-VALUE RANGE			OPTION					
NTC	A	FLEX	05	103 = $10 \times 10^3 \Omega$	473 = $47 \times 10^3 \Omega$	124 = $12.2 \times 10^4 \Omega$	F = $\pm 1\%$ G = $\pm 2\%$ H = $\pm 3\%$	L (low) = $3000 \leq B_{25/85} < 3500$	M (medium) = $3500 \leq B_{25/85} < 3750$	H (high) = $3750 \leq B_{25/85} < 4000$	X (very high) = $4000 \leq B_{25/85} < 4250$	Blank				

MECHANICAL DATA

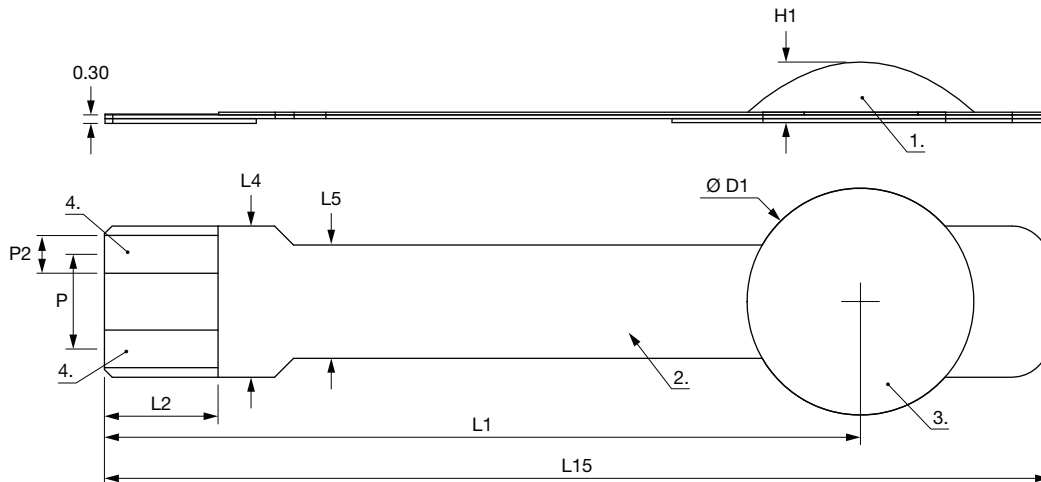

DIMENSIONS in millimeters								
L1	L15	L2	Ø D1	L4	L5	H1	P	P2
20 ± 1	25 ± 1	3 ± 0.5	6 ± 0.5	4 ± 1	3 ± 1	1.40 ± 0.2	2.50	1

1. NTC on flex foil circuit, sensing area on the flat bottom side
2. Flex foil circuit
3. High quality modified epoxy glob top
4. Conductive tracks, gold plated

RELIABILITY TEST (following IEC 60068 test methods)		
TEST	PROCEDURE	REQUIREMENT
Dry heat, steady state	125 °C; 1000 h	$\Delta R/R \leq 3\%$
Damp heat, steady state	56 days at 40 °C 90 % to 95 % RH	$\Delta R/R \leq 3\%$
Rapid change of temperature	-40 °C to +125 °C; 100 cycles	$\Delta R/R \leq 3\%$



Disclaimer

ALL PRODUCT, PRODUCT SPECIFICATIONS AND DATA ARE SUBJECT TO CHANGE WITHOUT NOTICE TO IMPROVE RELIABILITY, FUNCTION OR DESIGN OR OTHERWISE.

Vishay Intertechnology, Inc., its affiliates, agents, and employees, and all persons acting on its or their behalf (collectively, "Vishay"), disclaim any and all liability for any errors, inaccuracies or incompleteness contained in any datasheet or in any other disclosure relating to any product.

Vishay makes no warranty, representation or guarantee regarding the suitability of the products for any particular purpose or the continuing production of any product. To the maximum extent permitted by applicable law, Vishay disclaims (i) any and all liability arising out of the application or use of any product, (ii) any and all liability, including without limitation special, consequential or incidental damages, and (iii) any and all implied warranties, including warranties of fitness for particular purpose, non-infringement and merchantability.

Statements regarding the suitability of products for certain types of applications are based on Vishay's knowledge of typical requirements that are often placed on Vishay products in generic applications. Such statements are not binding statements about the suitability of products for a particular application. It is the customer's responsibility to validate that a particular product with the properties described in the product specification is suitable for use in a particular application. Parameters provided in datasheets and / or specifications may vary in different applications and performance may vary over time. All operating parameters, including typical parameters, must be validated for each customer application by the customer's technical experts. Product specifications do not expand or otherwise modify Vishay's terms and conditions of purchase, including but not limited to the warranty expressed therein.

Hyperlinks included in this datasheet may direct users to third-party websites. These links are provided as a convenience and for informational purposes only. Inclusion of these hyperlinks does not constitute an endorsement or an approval by Vishay of any of the products, services or opinions of the corporation, organization or individual associated with the third-party website. Vishay disclaims any and all liability and bears no responsibility for the accuracy, legality or content of the third-party website or for that of subsequent links.

Except as expressly indicated in writing, Vishay products are not designed for use in medical, life-saving, or life-sustaining applications or for any other application in which the failure of the Vishay product could result in personal injury or death. Customers using or selling Vishay products not expressly indicated for use in such applications do so at their own risk. Please contact authorized Vishay personnel to obtain written terms and conditions regarding products designed for such applications.

No license, express or implied, by estoppel or otherwise, to any intellectual property rights is granted by this document or by any conduct of Vishay. Product names and markings noted herein may be trademarks of their respective owners.