

FEATURES

- STACKED METALLIZED POLYETHYLENE NAPHTHALATE (PEN) FILM
- STANDARD EIA 1206, 1210, 1913, 2416, 2820, 3022 AND 3925 SIZES
- WIDE TEMPERATURE RANGE UP TO +125°C*
- HIGH HEAT AND MOISTURE RESISTANT
- VERY STABLE TEMPERATURE, FREQUENCY AND VOLTAGE BIAS CHARACTERISTICS
- REFLOW SOLDERING ONLY
- TAPE AND REEL PACKAGING

NSWC IS RECOMMENDED FOR NEW DESIGNS



RoHS Compliant
includes all homogeneous materials

*See Part Number System for Details

SPECIFICATIONS	Case Sizes						
	1206	1210	1913	2416	2820	3022	3925
Capacitance Range	0.001 ~ 0.0047μF	0.0056 ~ 0.01μF	0.012 ~ 0.082μF	0.1 ~ 0.15μF	0.18 ~ 0.33μF	0.39 ~ 0.47μF	0.56 ~ 1.0μF
Voltage Ratings	100Vdc						
Capacitance Tolerance	0.001 ~ 0.01μF 5% (J) only, 0.012 ~ 0.15μF 5% (J) or 10% (K), 0.18 ~ 1.0μF 10% (K) only						
Temperature Range	-55°C ~ +105°C (0.001μF ~ 0.01μF) -55°C ~ +125°C (0.012μF ~ 1.0μF with derating above +85°C)						
Dissipation factor (20°C)	1.0% max. @ 1KHz						
Insulation resistance (20°C)	3 Gigohms or 1000Ω/F whichever is lower						
Dielectric Withstanding Voltage	150% of Rated Voltage 60 Seconds						

ENVIRONMENTAL CHARACTERISTICS

Life Test At +105°C 1,000 Hours at 125% of Rated Voltage (125°C for 0.012μF ~ 1.0μF)	Capacitance Change	Within +1%/-6% of Initial Value	
	Dissipation Factor	1.1% Maximum	
	Insulation Resistance	1 Gigohm Minimum or 300Ω/F whichever is lower	
Resistance to Soldering Heat: +250°C Peak	Capacitance Change	Within ±5% for 0.012 ~ 1.0μF or ±3% for 0.001 ~ 0.01μF of initial value	
	Dissipation Factor	1.1% Max. for 0.012 ~ 1.0μF or 0.66% Max. for 0.001 ~ 0.01μF	
	Insulation Resistance	1 Gigohm Minimum or 300Ω/F whichever is lower	
Humidity Load Life (90% ~ 95% RH) (1) 1,000 Hours, +40°C 500 Hours for 0.012μF ~ 1.0μF (2) 500 Hours, +60°C for 0.001 ~ 0.01μF	Capacitance Change	(1) +8%/-5%	(2) ±10% of Initial Value
	Dissipation Factor	(1) 1.5% Max.	(2) 2.0% Max.
	Insulation Resistance	(1) 100 Megohm Min. or 30Ω/F (2) 10 Megohm Min. or 3Ω/F whichever is lower	
Solderability with 25% Wt Rosin-Methanol Flux	90% Minimum Coverage After 2.5 Second Dip Into 245°C Solder Pot		

RECOMMENDED LAND PATTERN (mm)

EIA Size	A	B	C
1206	1.8	3.6	1.4
1210	1.8	3.6	2.3
1913	2.6	6.6	3.0
2416	3.8	7.8	3.8
2820	4.5	9.0	4.6
3022	5.1	9.7	5.0
3925	7.2	11.9	5.7

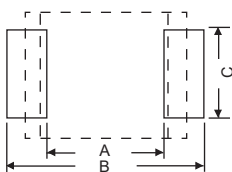

RECOMMENDED REFLOW PROFILE

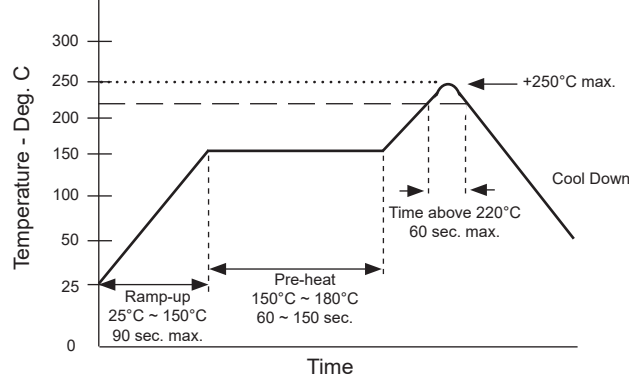

PART NUMBER SYSTEM

NSWC 823 J 100 TR D4 F

Series
Capacitance in pF, 1st two digits are significant, 3rd digit is no. of zeros
Tolerance Code: J = ±5%
Voltage
Tape & Reel
Size Code
RoHS Compliant
*Special packaging and handling required.



TAPE DIMENSIONS (mm)

Case Code	A±0.1	B±0.1	C±0.2	t	W±0.3	F	P±0.1	D+0.2/-0	Qty/Reel
B2	1.9	3.5	1.5	0.25	8.0	3.5	4.0	1.0	3,000
B3			1.9						2,000
C2	1.9		2,000						
C3	2.8	2.5	2,000						
D1	3.8	5.1	2.0	0.3 ±0.05	12.0	5.5 ±0.05	8.0	1.5	3,000
D2			2.6						3,000
D3, D4	3.4		2,000						
E1, E2	4.6	6.3	2.7	-	-	-	-	-	3,000
E3, E4			3.5						2,000
G1 ~ G5	5.5	7.4	4.7	0.343 ±0.013	16.0	7.5 ±0.1	12.0	1.5	1,500
Q1, Q2	6.91	8.43	5.685						1,000
R1 ~ R8	8.94	10.54	5.795	1,000					

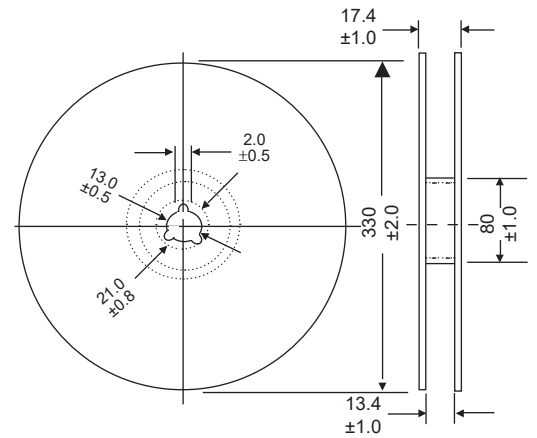

EMBOSED PLASTIC CARRIER

