

Hybrid Aluminum Electrolytic Capacitors

NSPE-H Series

- CYLINDRICAL V-CHIP CONSTRUCTION FOR SURFACE MOUNTING
- EXTENDED LOAD LIFE AT HIGH TEMPERATURE (2000 ~ 10,000 HOURS @ +105°C)
- HIGH VOLTAGE RATINGS (16 ~ 125VDC)
- LOW ESR AND HIGH RIPPLE CURRENT RATINGS
- 6.3x6.3mm ~ 10x12.8mm CASE SIZES
- REFLOW SOLDERING RATED UP TO +260°C
- MEETS THE REQUIREMENTS OF AEC-Q200*

Available with Wide
Anti-Vibration, Terminations

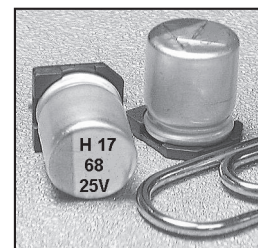

CHARACTERISTICS

Rated Voltage Range	16 ~ 125Vdc		
Rated Capacitance Range	2.7 ~ 560μF		
Operating Temp. Range	-55 ~ +105°C		
Capacitance Tolerance	±20% (M)		
Max. Leakage Current After 2 Minutes @ 20°C	16 ~ 63Vdc	Less than 0.01CV or 3μA whichever is greater	
	80 ~ 125Vdc	Less than 0.05CV or 100μA whichever is greater	
Working and Surge Voltage Ratings	W.V. (Vdc)	16 25 35 40 50 63 80 100 125	
	S.V. (Vdc)	20 32 44 50 63 79 100 125 157	
Tan δ @ 120Hz/20°C		0.16	
Impedance Ratio	Z -55°C/Z +20°C	1 ~ 2.5	
	Z +105°C/Z +20°C	0.6 ~ 1.0	
Load Life Test @ 105°C and Rated Voltage	W.V. (Vdc)	16 25 35 40 50 63 80 100 125	
	Case Dia.	φ6.3mm	3000 hrs. 5000 hrs. - - -
		φ8 & 10mm	7000 hrs. 10000 hrs.
	Capacitance Change	Within ±30% of initial measured value	
	Tan δ and ESR	Less than 200% of specified max. value	
Leakage Current	Less than specified max. value		

STANDARD PRODUCTS AND CASE SIZES Dφ x L (mm)

PART NUM __ER	Cap. (μF)	Working Voltage	Case Size (D X L) mm	Max. Tan δ 120Hz/20°C	Max. ESR (mΩ) AT 100KHz/20°C	Max. Ripple Current (mA rms) AT 100KHz/105°C	Load Life Hours (+105°C)
NSPE-H820M16V6.3X6.3N__F	82	16	6.3X6.3	0.16	55	1330	3000
NSPE-H121M16V6.3X8N__F	120		6.3X8	0.16	40	1500	3000
NSPE-H271M16V8X10.8N__F	270		8X10.8	0.16	26	2000	7000
NSPE-H471M16V10X10.8N__F	470		10X10.8	0.16	21	2600	7000
NSPE-H561M16V10X12.8N__F	560		10X12.8	0.16	15	3000	7000
NSPE-H470M25V6.3X6.3N__F	47	25	6.3X6.3	0.16	60	1270	5000
NSPE-H680M25V6.3X8N__F	68		6.3X8	0.16	45	1400	5000
NSPE-H151M25V8X10.8N__F	150		8X10.8	0.16	27	1900	10000
NSPE-H271M25V10X10.8N__F	270		10X10.8	0.16	22	2530	10000
NSPE-H331M25V10X12.8N__F	330		10X12.8	0.16	16	2900	10000
NSPE-H270M35V6.3X6.3N__F	27	35	6.3X6.3	0.16	100	1080	5000
NSPE-H470M35V6.3X8N__F	47		6.3X8	0.16	60	1300	5000
NSPE-H101M35V8X10.8N__F	100		8X10.8	0.16	30	1800	10000
NSPE-H151M35V10X10.8N__F	150		10X10.8	0.16	23	2470	10000
NSPE-H221M35V10X12.8N__F	220		10X12.8	0.16	17	2830	10000
NSPE-H180M40V6.3X6.3N__F	18	40	6.3X6.3	0.16	110	1030	5000
NSPE-H270M40V6.3X8N__F	27		6.3X8	0.16	70	1250	5000
NSPE-H560M40V8X10.8N__F	56		8X10.8	0.16	32	1750	10000
NSPE-H101M40V10X10.8N__F	100		10X10.8	0.16	24	2400	10000
NSPE-H121M40V10X12.8N__F	120		10X12.8	0.16	18	2750	10000
NSPE-H5R6M50V6.3X6.3N__F	5.6	50	6.3X6.3	0.16	120	980	5000
NSPE-H100M50V6.3X6.3N__F	10		6.3X6.3	0.16	120	980	5000

Part Number Suffix Where __ : Preferred (15" reel) = LB, Legacy (13" reel) = B (check with NIC for availability)

For Automotive Applications See Part Numbering System



STANDARD PRODUCTS AND CASE SIZES D ϕ x L (mm)

PART NUMBER	Cap. (μ F)	Working Voltage	Case Size (D X L) mm	Max. Tan δ 120Hz/20°C	Max. ESR (m Ω) AT 100KHz/20°C	Max. Ripple Current (mA rms) AT 100KHz/105°C	Load Life Hours (+105°C)	
NSPE-H100M50V6.3X8N__F	10	50	6.3X8	0.16	80	1200	5000	
NSPE-H150M50V6.3X8N__F	15		6.3X8	0.16	80	1200	5000	
NSPE-H330M50V8X10.8N__F	33		8X10.8	0.16	35	1670	10000	
NSPE-H560M50V10X10.8N__F	56		10X10.8	0.16	25	2320	10000	
NSPE-H820M50V10X12.8N__F	82		10X12.8	0.16	19	2650	10000	
NSPE-H2R7M63V6.3X6.3N__F	2.7		63	6.3X6.3	0.16	150	960	5000
NSPE-H3R9M63V6.3X8N__F	3.9	6.3X8		0.16	100	1060	5000	
NSPE-H6R8M63V6.3X6.3N__F	6.8	6.3X6.3		0.16	150	960	5000	
NSPE-H100M63V6.3X8N__F	10	6.3X8		0.16	100	1060	5000	
NSPE-H220M63V8X10.8N__F	22	8X10.8		0.16	40	1560	10000	
NSPE-H330M63V8X10.8N__F	33	8X10.8		0.16	40	1560	10000	
NSPE-H330M63V10X10.8N__F	33	10X10.8		0.16	30	2100	10000	
NSPE-H470M63V10X10.8N__F	47	10X10.8		0.16	30	2100	10000	
NSPE-H560M63V10X12.8N__F	56	10X12.8		0.16	22	2400	10000	
NSPE-H120M80V10X10.8L__F	12	80		10X10.8	0.16	70	1600	10000
NSPE-H150M80V10X10.8L__F	15			10X10.8	0.16	70	1600	10000
NSPE-H180M80V10X12.8L__F	18			10X12.8	0.16	50	1830	10000
NSPE-H100M100V10X10.8L__F	10	100	10X10.8	0.16	80	1450	10000	
NSPE-H120M100V10X10.8L__F	12		10X10.8	0.16	80	1450	10000	
NSPE-H150M100V10X12.8L__F	15		10X12.8	0.16	60	1660	10000	
NSPE-H100M125V10X10.8L__F	10		125	10X10.8	0.16	90	1250	10000

Part Number Suffix Where __ : Preferred (15" reel) = LB, Legacy (13" reel) = B (check with NIC for availability)

For Automotive Applications See Part Numbering System

RIPPLE CURRENT FREQUENCY CORRECTION FACTORS

Cap. μ F	100Hz	1KHz	10KHz	100KHz
C \leq 4.7	0.03	0.30	0.65	1.00
5.6 ~ 33	0.05	0.32	0.67	1.00
> 33	0.10	0.35	0.70	1.00

PRECAUTIONS

Please review the notes on correct use, safety and precautions found at <https://www.niccomp.com/resource/files/aluminum/AlumApplInfoCautions.pdf>
If in doubt or uncertainty, please review your specific application - process details with NIC's technical support personnel: tpmg@niccomp.com



PART NUMBER SYSTEM

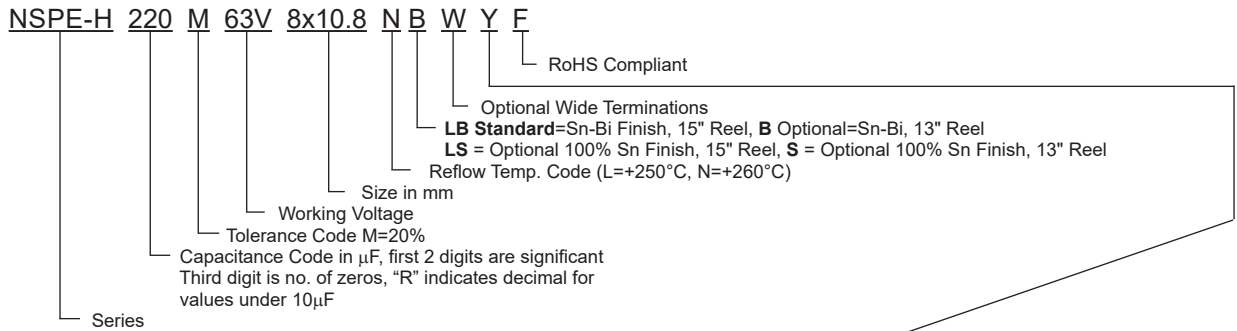

Optional: Suitable for automotive equipment, sourced to special production and inspection at IATF-16949 certified production site

Code	Plating	Termination Type	Automotive	Reel Size
LB	Sn-Bi	Standard	No	Standard 15" Reel
LBW	Sn-Bi	Wide Terminations	No	Standard 15" Reel
LBY	Sn-Bi	Standard	Yes	Standard 15" Reel
LBWY	Sn-Bi	Wide Terminations	Yes	Standard 15" Reel
B	Sn-Bi	Standard	No	Optional 13" Reel
BW	Sn-Bi	Wide Terminations	No	Optional 13" Reel
BY	Sn-Bi	Standard	Yes	Optional 13" Reel
BWY	Sn-Bi	Wide Terminations	Yes	Optional 13" Reel
LS	100% Sn	Standard	No	Standard 15" Reel
LSW	100% Sn	Wide Terminations	No	Standard 15" Reel
LSY	100% Sn	Standard	Yes	Standard 15" Reel
LSWY	100% Sn	Wide Terminations	Yes	Standard 15" Reel
S	100% Sn	Standard	No	Optional 13" Reel
SW	100% Sn	Wide Terminations	No	Optional 13" Reel
SY	100% Sn	Standard	Yes	Optional 13" Reel
SWY	100% Sn	Wide Terminations	Yes	Optional 13" Reel

COMPONENT DIMENSIONS (mm)

Case Size	$D\phi \pm 0.5$	L max.	A, B ± 0.2	W	$l \pm 0.2$	$P \pm 0.2$
6.3X6.3	6.3	6.3	6.6	0.5 ~ 0.8	2.5	2.2
6.3X8	6.3	8.0	6.6	0.5 ~ 0.8	2.5	2.2
8X10.8	8.0	10.8	8.3	0.7 ~ 1.0	2.9	3.2
10X10.8	10	10.8	10.3	1.0 ~ 1.4	3.2	4.6
10X12.8	10	12.8	10.3	1.0 ~ 1.4	3.2	4.6

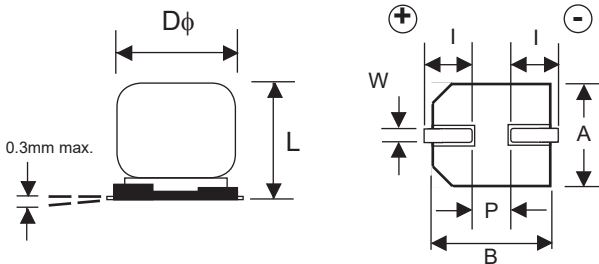

STANDARD TERMINATION LAND PATTERN DIM. (mm)

Case Dia.	A	B	P
6.3	3.6	1.8	1.8
8	4.1	2.1	2.8
10	4.4	2.5	4.3

Part Marking

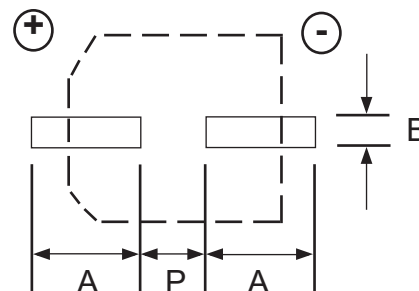
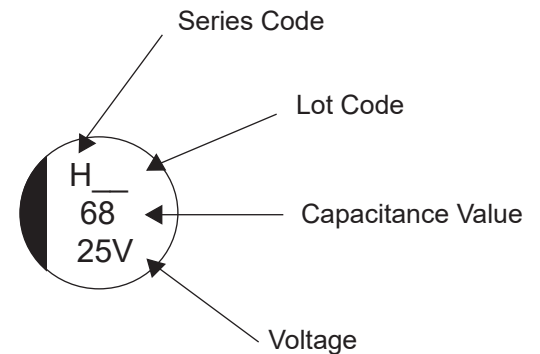

W (Wide Terminations) Anti-Vibration Test	
Test Method	Direction: X, Y, Z axis Frequency & Duration: 5 to 2000Hz reciprocation for 20 minutes, 2 hours each direction Peak to Peak Amplitude: 5mm Peak Acceleration: 30G Sweep Type: Log
Δ Capacitance	Within ± 10% of initial value
Tangent of Loss	≤ Specified value
Leakage Current	≤ Specified value

WIDE TERMINATION DIM. (mm)

Case Size	Dφ ±0.5	L max.	A, B	C ±0.2	P ±0.2	W	R	T
6.3x6.3WT	6.3	6.5	6.6 ± 0.2	7.3	(2.2)	0.5 ~ 0.8	(1.7)	(0.7)
6.3x8WT	6.3	8.2	6.6 ± 0.2	7.8	(2.2)	0.5 ~ 0.8	(1.7)	(0.7)
8 x 10.8WT	8.0	11.0	8.3 ± 0.2	9.0	3.2	0.7 ~ 1.0	(0.7)	(1.3)
10 x 10.8WT	10.0	11.0	10.3 ± 0.2	11.0	4.6	1.0 ~ 1.4	(0.7)	(1.3)
10 x 12.8WT	10.0	13.5	10.3 ± 0.2	11.0	4.6	1.0 ~ 1.4	(0.7)	(1.3)

WIDE TERMINATION LAND PATTERN DIM. (mm)

Case Size	a	b	c
6.3x6.3	1.6	4.0	3.0
6.3x8	1.6	4.0	3.0
8x10.8	2.5	4.5	4.7
10x10.8	3.8	4.8	4.7
10x12.8	3.8	4.8	4.7

WT STYLE TERMINATION

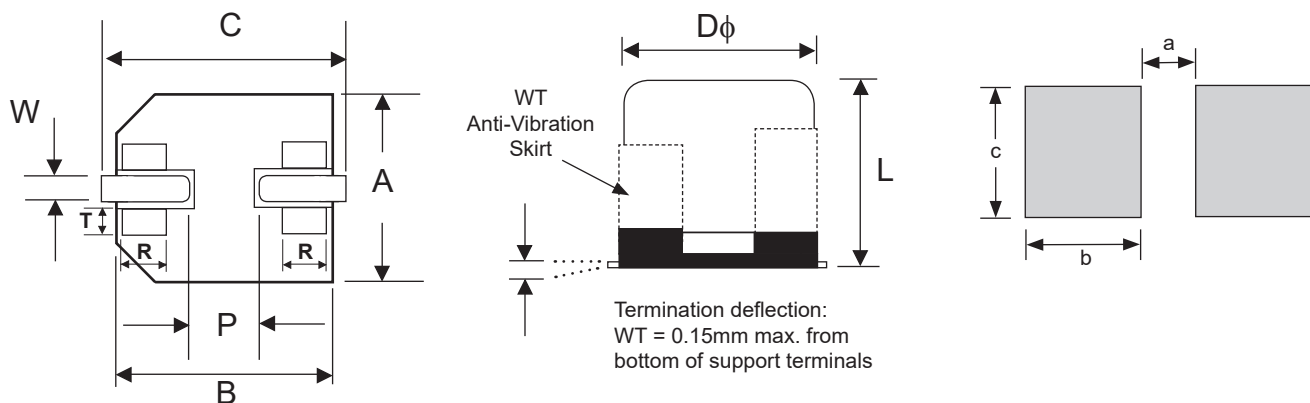

Review & Compare Reflow Soldering Heat Limits
V-chip SMT Aluminum Electrolytic Capacitors
www.niccomp.com/RSL



RECOMMENDED REFLOW SOLDERING PROFILE*

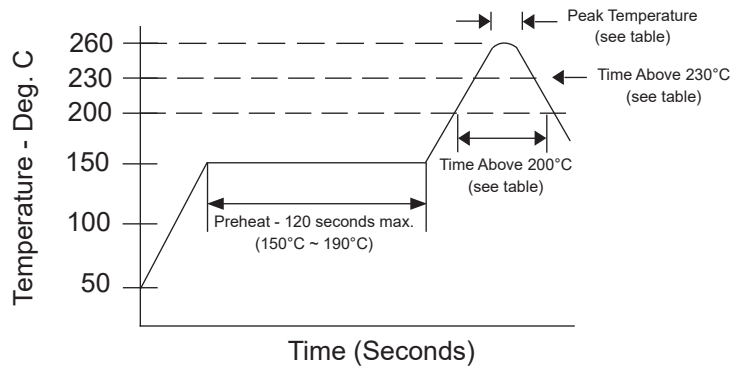

PEAK TEMPERATURE AND DURATION (16V ~ 63V)

Diameter	Time above 200°C	Time above 217°C	Time above 230°C	Peak Temperature
6.3 ~ 10mm	100 sec. max.	80 sec. max.	40 sec. max.	260°C/5 sec.

PEAK TEMPERATURE AND DURATION (80V ~ 125V)

Diameter	Time above 200°C	Time above 217°C	Time above 230°C	Peak Temperature
10mm	100 sec. max.	80 sec. max.	40 sec. max.	250°C/5 sec.

*Two reflow passes are permissible with a cool down to room temperature required between the first and second pass.

TAPING SPECIFICATIONS (mm)

- Both Leader and Trailer tape: Minimum 40mm (1.57") empty carrier tape pockets.
- Leader tape: Approximately 20cm of cover tape at leader.
- Connection: Maximum 3 connections (slices) per reel.

Case Size	A ±0.5	B ±0.5	C ±0.3	D ±0.1	P ±0.1	T ±0.2	t max.
6.3X6.3	7.0	7.0	16.0	7.5	12.0	6.5	0.6
6.3X8	7.0	7.0	16.0	7.5	12.0	8.2	0.6
8X10.8	8.7	8.7	24.0	11.5	16.0	11.0	0.6
10X10.8	10.7	10.7	24.0	11.5	16.0	11.0	0.6
10X12.8	10.7	10.7	24.0	11.5	16.0	13.3	0.6

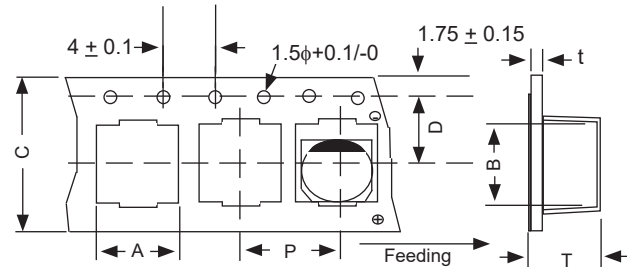

Standard V-Chip 15" (380mm) Reels (LB suffix)

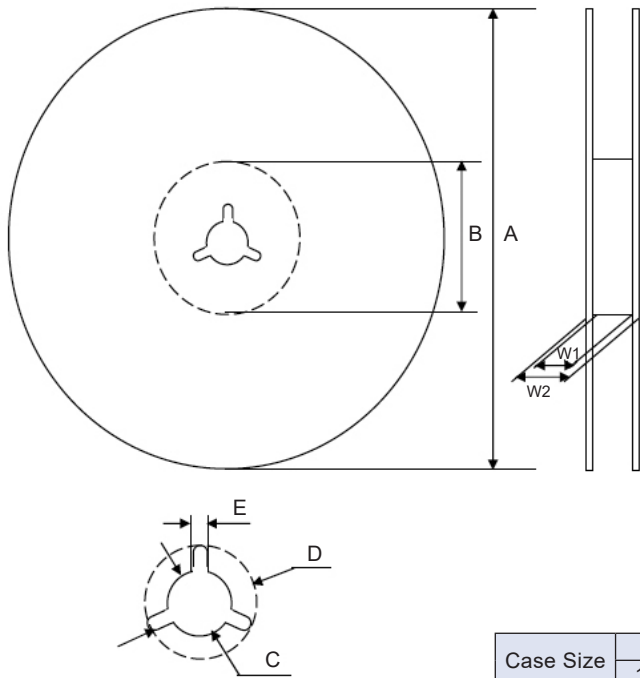

Dimensions (mm)

Case Size	Tape Width	W1	W2
6.3x6.3, 6.3x8	16.0	16.5 ~ 18.5	19.5 ~ 24.0
8x10.8, 10x10.8, 10x12.8	24.0	24.5 ~ 26.5	27.5 ~ 32.0

Case Size	Tape Width	A	B	C	D	E
6.3x6.3, 6.3x8	16.0	$\phi 380 \pm 2$	$\phi 80 \sim 105$	$\phi 13 \pm 0.5$	$\phi 21 \pm 1.0$	2.0 ± 0.5
8x10.8, 10x10.8, 10x12.8	24.0					

Color
Black

Case Size	Qty per Reel	
	13" (330mm)	15" (380mm)
6.3X6.3	800	1000
6.3X8	500	900
8X10.8	300	500
10X10.8	300	500
10X12.8	300	400

Optional V-Chip 13" (330mm) Reels (B suffix)

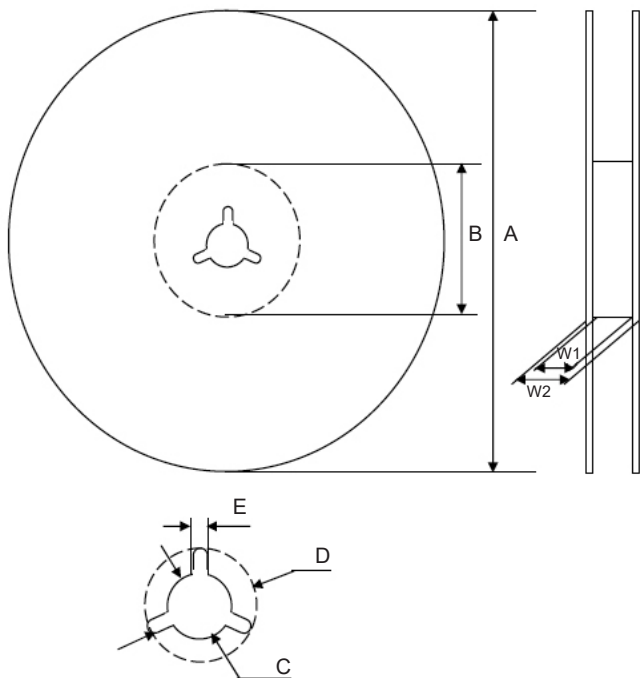

Dimensions (mm)

Case Size	Tape Width	W1	W2
6.3x6.3, 6.3x8	16.0	16.4 ~ 18.5	19.5 ~ 24.0
8x10.8, 10x10.8, 10x12.8	24.0	24.4 ~ 26.5	27.5 ~ 32.0

Case Size	Tape Width	A	B	C	D	E
6.3x6.3, 6.3x8	16.0	$\phi 330 \pm 2.0$	$\phi 50 \sim 105$	$\phi 13 \pm 0.5$	$\phi 21 \pm 1.0$	2.0 ± 0.5
8x10.8, 10x10.8, 10x12.8	24.0					

Color
Black