

DS36277

Dominant Mode Multipoint Transceiver

General Description

The DS36277 Dominant Mode Multipoint Transceiver is designed for use on bi-directional differential busses. It is optimal for use on Interfaces that utilize Society of Automotive Engineers (SAE) J1708 Electrical Standard.

The device is similar to standard TIA/EIA-485 transceivers, but differs in enabling scheme. The Driver's Input is normally externally tied LOW, thus providing only two states: Active (LOW), or Disabled (OFF). When the driver is active, the dominant mode is LOW, conversely, when the driver is disabled, the bus is pulled HIGH by external bias resistors.

The receiver provides a FAILSAFE feature that guarantees a known output state when the Interface is in the following conditions: Floating Line, Idle Line (no active drivers), and Line Fault Conditions (open or short). The receiver output is HIGH for the following conditions: Open Inputs, Terminated Inputs (50Ω), or Shorted Inputs. FAILSAFE is a highly desirable feature when the transceivers are used with Asynchronous Controllers such as UARTs.

Features

- FAILSAFE receiver, RO = HIGH for:
 - OPEN inputs
 - Terminated inputs
 - SHORTED inputs
- Optimal for use in SAE J1708 Interfaces
- Compatible with popular interface standards:
 - TIA/EIA-485 and TIA/EIA-422-A
 - CCITT recommendation V.11
- Bi-directional transceiver
 - Designed for multipoint transmission
- Wide bus common mode range
 - (-7V to +12V)
- Available in plastic DIP and SOIC packages

Connection and Logic Diagram

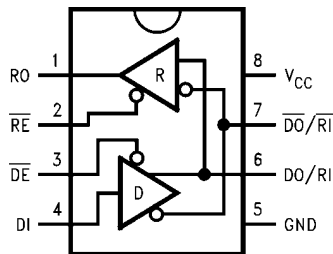

1138401
 Order Number DS36277TM or DS36277TN
 See NS Package Number M08A or N08E

Truth Table

Driver			
Inputs		Outputs	
\overline{DE}	DI	DO/RI	$\overline{DO}/\overline{RI}$
L	L	L	H
L	H	H	L
H	X	Z	Z

Receiver		
Inputs	Output	
\overline{RE}	DO/RI- $\overline{DO}/\overline{RI}$	RO
L	≥ 0 mV	H
L	≤ -500 mV	L
L	SHORTED	H
L	OPEN	H
H	X	Z

Absolute Maximum Ratings (Note 1)

If Military/Aerospace specified devices are required, please contact the National Semiconductor Sales Office/ Distributors for availability and specifications.

Supply Voltage (V_{CC})	7V
Input Voltage (\overline{DE} , RE, and DI)	5.5V
Driver Output Voltage/	
Receiver Input Voltage	-10V to +15V
Receiver Output Voltage (RO)	5.5V
Maximum Package Power Dissipation @ +25°C	
N Package (derate 9.3 mW/°C above +25°C)	1168 mW
M Package (derate 5.8 mW/°C above +25°C)	726 mW

Storage Temperature Range	-65°C to +150°C
Lead Temperature (Soldering 4 sec.)	260°C
ESD Rating (HBM, 1.5 kΩ, 100 pF)	7.0 kV

Recommended Operating Conditions

	Min	Max	Units
Supply Voltage, V_{CC}	4.75	5.25	V
Bus Voltage	-7	+12	V
Operating Temperature (T_A)			
DS36277T	-40	+85	°C

Electrical Characteristics (Notes 2, 4)

Over recommended Supply Voltage and Operating Temperature ranges, unless otherwise specified.

Symbol	Parameter	Conditions	Min	Typ	Max	Units		
DRIVER CHARACTERISTICS								
V_{OD}	Differential Output Voltage	$I_O = 0$ mA (No Load)	1.5	3.6	6	V		
V_{oDO}	Output Voltage	$I_O = 0$ mA (Output to GND)	0		6	V		
$V_{o\overline{DO}}$	Output Voltage		0		6	V		
V_{T1}	Differential Output Voltage (Termination Load)	$R_L = 54\Omega$ (485)	(Figure 1)		1.3	2.2	5.0	V
		$R_L = 100\Omega$ (422)			1.7	2.6	5.0	V
ΔV_{T1}	Balance of V_{T1} $ V_{T1} - \overline{V_{T1}} $	$R_L = 54\Omega$	(Note 3)		-0.2		0.2	V
		$R_L = 100\Omega$			-0.2		0.2	V
V_{OS}	Driver Common Mode Output Voltage	$R_L = 54\Omega$	(Figure 1)		0	2.5	3.0	V
		$R_L = 100\Omega$			0	2.5	3.0	V
ΔV_{OS}	Balance of V_{OS} $ V_{OS} - \overline{V_{OS}} $	$R_L = 54\Omega$	(Note 3)		-0.2		0.2	V
		$R_L = 100\Omega$			-0.2		0.2	V
V_{OH}	Output Voltage High	$I_{OH} = -22$ mA	(Figure 2)		2.7	3.7		V
V_{OL}	Output Voltage Low	$I_{OL} = +22$ mA			1.3	2		V
I_{OSD}	Driver Short-Circuit Output Current	$V_O = +12V$	(Figure 3)			92	290	mA
		$V_O = -7V$				-187	-290	mA
RECEIVER CHARACTERISTICS								
V_{TH}	Differential Input High Threshold Voltage (Note 5)	$V_O = V_{OH}$, $I_O = -0.4$ mA $-7V \leq V_{CM} \leq +12V$			-0.150	0		V
V_{TL}	Differential Input Low Threshold Voltage (Note 5)	$V_O = V_{OL}$, $I_O = 8.0$ mA $-7V \leq V_{CM} \leq +12V$	-0.5		-0.230			V
V_{HST}	Hysteresis (Note 6)	$V_{CM} = 0V$			80			mV
I_{IN}	Line Input Current ($V_{CC} = 4.75V, 5.25V, 0V$)	Other Input = 0V	$V_I = +12V$			0.5	1.5	mA
		$\overline{DE} = V_{IH}$ (Note 7)	$V_I = -7V$			-0.5	-1.5	mA
I_{OSR}	Short Circuit Current	$V_O = 0V$	RO		-15	-32	-85	mA
I_{OZ}	TRI-STATE® Leakage Current	$V_O = 0.4$ to 2.4V			-20	1.4	+20	μA
V_{OH}	Output High Voltage (Figure 12)	$V_{ID} = 0V$, $I_{OH} = -0.4$ mA			2.3	3.7		V
		$V_{ID} = OPEN$, $I_{OH} = -0.4$ mA			2.3	3.7		V
V_{OL}	Output Low Voltage (Figure 12)	$V_{ID} = -0.5V$, $I_{OL} = +8$ mA				0.3	0.7	V
		$V_{ID} = -0.5V$, $I_{OL} = +16$ mA			0.3	0.8	V	
R_{IN}	Input Resistance				10	20		kΩ

Symbol	Parameter	Conditions	Min	Typ	Max	Units
DEVICE CHARACTERISTICS						
V_{IH}	High Level Input Voltage		2.0		V_{CC}	V
V_{IL}	Low Level Input Voltage		GND		0.8	V
I_{IH}	High Level Input Current	$V_{IH} = 2.4V$			20	μA
I_{IL}	Low Level Input Current	$V_{IL} = 0.4V$			-100	μA
V_{CL}	Input Clamp Voltage	$I_{CL} = -18 mA$		-0.7	-1.5	V
I_{CC}	Output Low Voltage	$\overline{DE} = 0V, \overline{RE} = 0V, DI = 0V$		39	60	mA
I_{CCR}	Supply Current	$\overline{DE} = 3V, \overline{RE} = 0V, DI = 0V$		24	50	mA
I_{CCD}	(No Load)	$\overline{DE} = 0V, \overline{RE} = 3V, DI = 0V$		40	75	mA
I_{CCX}		$\overline{DE} = 3V, \overline{RE} = 3V, DI = 0V$		27	45	mA

Switching Characteristics (Note 4)

Over recommended Supply Voltage and Operating Temperature ranges, unless otherwise specified.

Symbol	Parameter	Conditions	Min	Typ	Max	Units
DRIVER CHARACTERISTICS						
t_{PLHD}	Diff. Prop. Delay Low to High	$R_L = 54\Omega$	8	17	60	ns
t_{PHLD}	Diff. Prop. Delay High to Low	$C_L = 50 pF$	8	19	60	ns
t_{SKD}	Diff. Skew ($t_{PLHD} - t_{PHLD}$)	$C_D = 50 pF$		2	10	ns
t_r	Diff. Rise Time	(Figures 4, 5)		11	60	ns
t_f	Diff. Fall Time			11	60	ns
t_{PLH}	Prop. Delay Low to High	$R_L = 27\Omega, C_L = 15 pF$		22	85	ns
t_{PHL}	Prop. Delay High to Low	(Figures 6, 7)		25	85	ns
t_{PZH}	Enable Time Z to High	$R_L = 110\Omega$		25	60	ns
t_{PZL}	Enable Time Z to Low	$C_L = 50 pF$		30	60	ns
t_{PHZ}	Disable Time High to Z	(Figure 8 – Figure 11)		16	60	ns
t_{PLZ}	Disable Time Low to Z			11	60	ns
RECEIVER CHARACTERISTICS						
t_{PLH}	Prop. Delay Low to High	$V_{ID} = -1.5V \text{ to } +1.5V$	15	37	90	ns
t_{PHL}	Prop. Delay High to Low	$C_L = 15 pF$	15	43	90	ns
t_{SK}	Skew ($t_{PLH} - t_{PHL}$)	(Figures 13, 14)		6	15	ns
t_{PZH}	Enable Time Z to High	$C_L = 15 pF$		12	60	ns
t_{PZL}	Enable Time Z to Low	(Figures 15, 16)		28	60	ns
t_{PHZ}	Disable Time High to Z			20	60	ns
t_{PLZ}	Disable Time Low to Z			10	60	ns

Note 1: “Absolute Maximum Ratings” are those values beyond which the safety of the device cannot be guaranteed. They are not meant to imply that the devices should be operated at these limits. The tables of “Electrical Characteristics” specify conditions for device operation.

Note 2: Current into device pins is defined as positive. Current out of device pins is defined as negative. All voltages are referenced to ground unless otherwise specified.

Note 3: ΔIV_{T1} and ΔIV_{OS} are changes in magnitude of V_{T1} and V_{OS} , respectively, that occur when the input changes state.

Note 4: All typicals are given for $V_{CC} = 5.0V$ and $T_A = +25^\circ C$.

Note 5: Threshold parameter limits specified as an algebraic value rather than by magnitude.

Note 6: Hysteresis defined as $V_{HST} = V_{TH} - V_{TL}$.

Note 7: I_{IN} includes the receiver input current and driver TRI-STATE leakage current.

Parameter Measurement Information

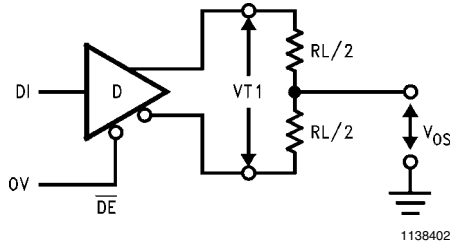

FIGURE 1. Driver V_{T1} and V_{OS} Test Circuit

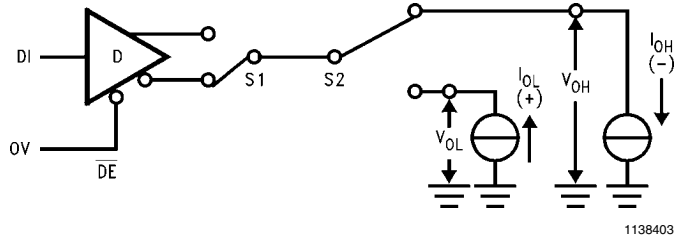

FIGURE 2. Driver V_{OH} and V_{OL} Test Circuit

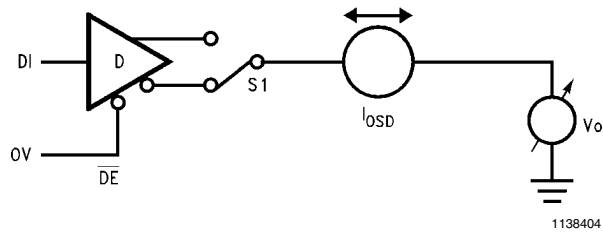

FIGURE 3. Driver Short Circuit Test Circuit

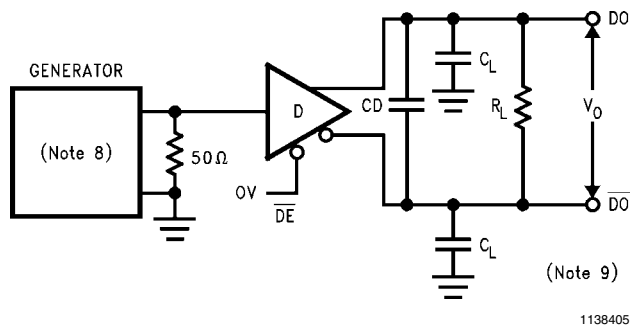

FIGURE 4. Driver Differential Propagation Delay and Transition Time Test Circuit

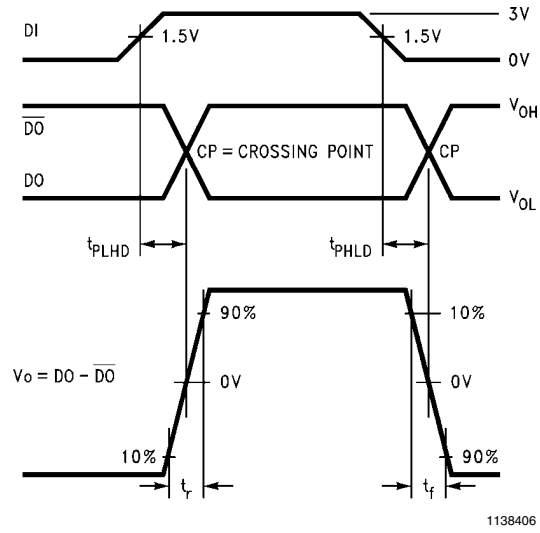

FIGURE 5. Driver Differential Propagation Delays and Transition Times

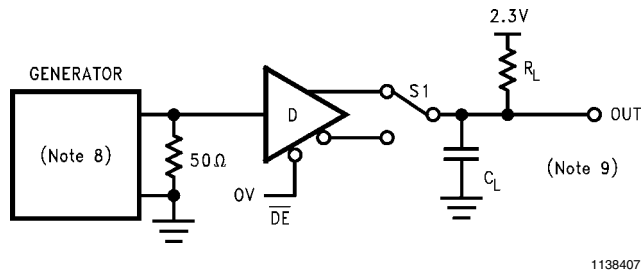

FIGURE 6. Driver Propagation Delay Test Circuit

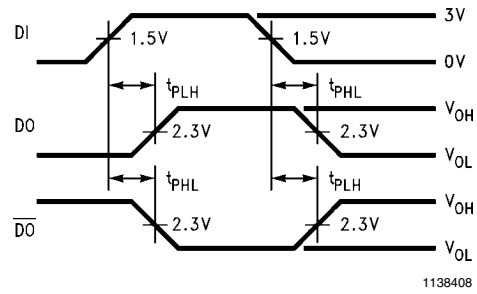
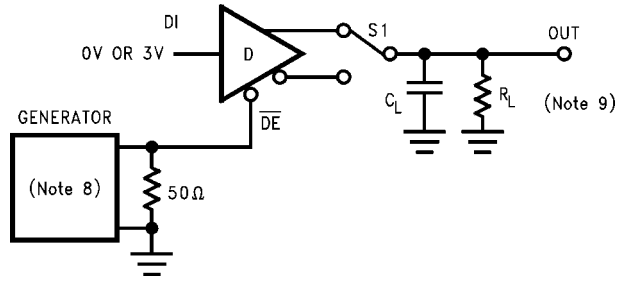

FIGURE 7. Driver Propagation Delays



1138409

S1 to DO for DI = 3V
S1 to \overline{DO} for DI = 0V

FIGURE 8. Driver TRI-STATE Test Circuit (t_{pZH} , t_{pHZ})

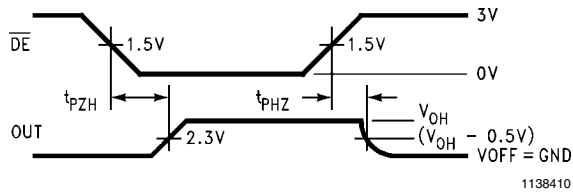

1138410

FIGURE 9. Driver TRI-STATE Delays (t_{pZH} , t_{pHZ})

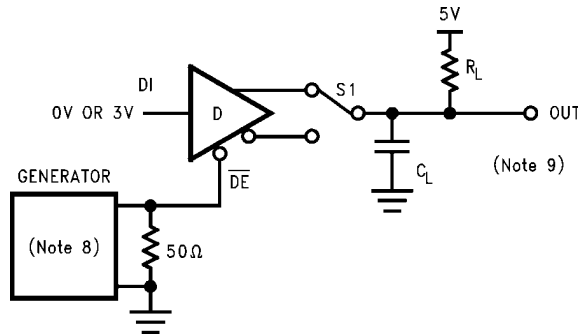

1138411

S1 to DO for DI = 0V
S1 to \overline{DO} for DI = 3V

FIGURE 10. Driver TRI-STATE Test Circuit (t_{pZL} , t_{pLZ})

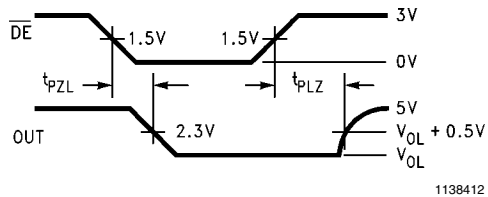

1138412

FIGURE 11. Driver TRI-STATE Delays (t_{pZL} , t_{pLZ})

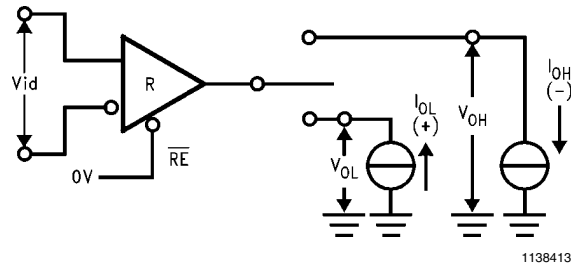

FIGURE 12. Receiver V_{OH} and V_{OL}

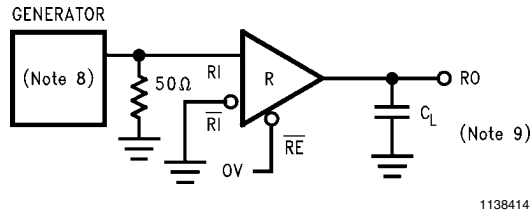

FIGURE 13. Receiver Propagation Delay Test Circuit

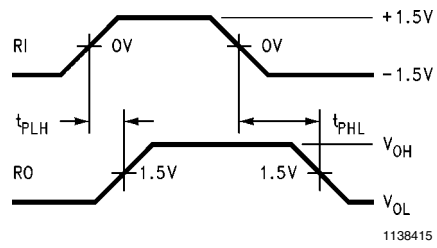

FIGURE 14. Receiver Propagation Delays

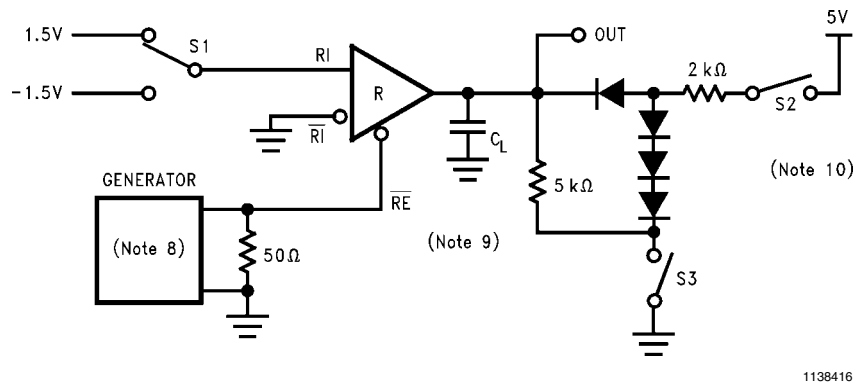
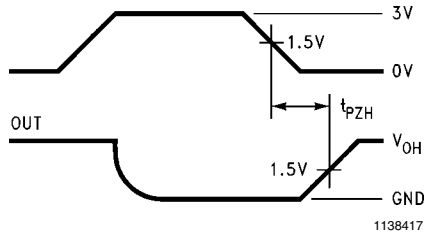
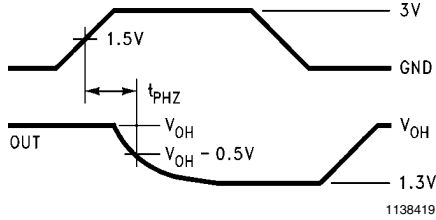

FIGURE 15. Receiver TRI-STATE Delay Test Circuit

S1 1.5V
S2 OPEN
S3 CLOSED



S1 1.5V
S2 CLOSED
S3 CLOSED



S1 -1.5V
S2 CLOSED
S3 OPEN

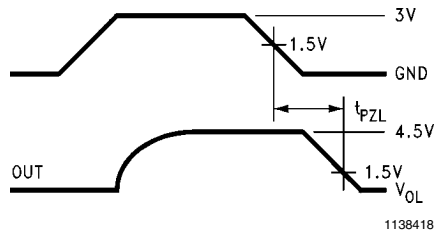

S1 -1.5V
S2 CLOSED
S3 CLOSED

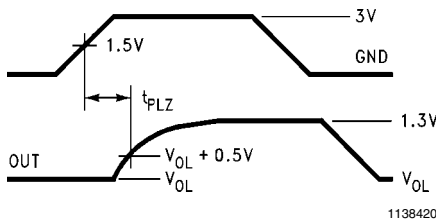

FIGURE 16. Receiver Enable and Disable Timing

Note 8: The input pulse is supplied by a generator having the following characteristics: $f = 1.0 \text{ MHz}$, 50% duty cycle, t_r and $t_f < 6.0 \text{ ns}$, $Z_0 = 50\Omega$.

Note 9: C_L includes probe and stray capacitance.

Note 10: Diodes are 1N916 or equivalent.

Typical Performance Characteristics

Differential Output Voltage vs Output Current

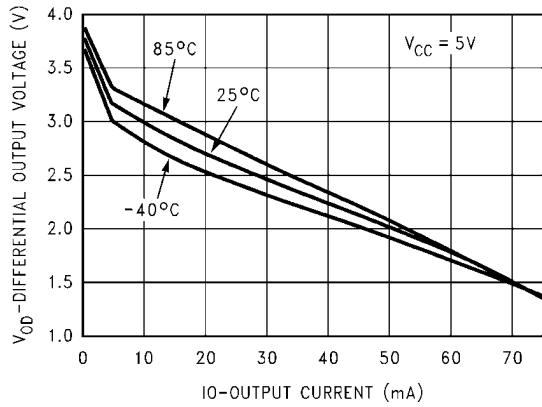

1138422

Differential Output Voltage vs Output Current

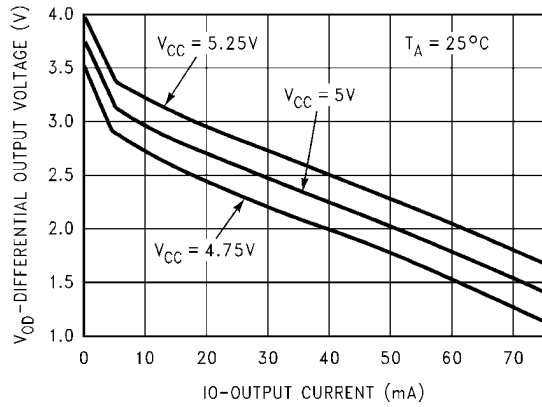

1138423

Driver V_{OH} vs I_{OH} vs V_{CC}

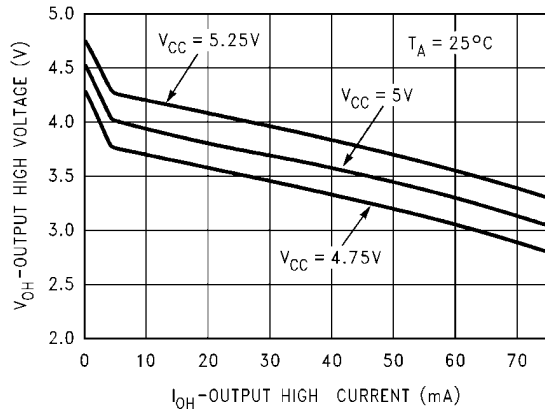

1138424

Driver V_{OH} vs I_{OH} vs Temperature

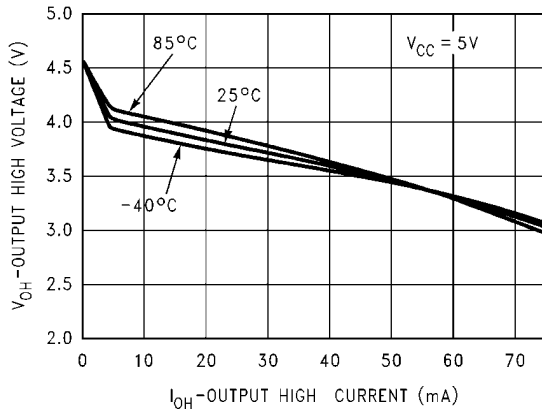

1138425

Driver V_{OL} vs I_{OL} vs V_{CC}

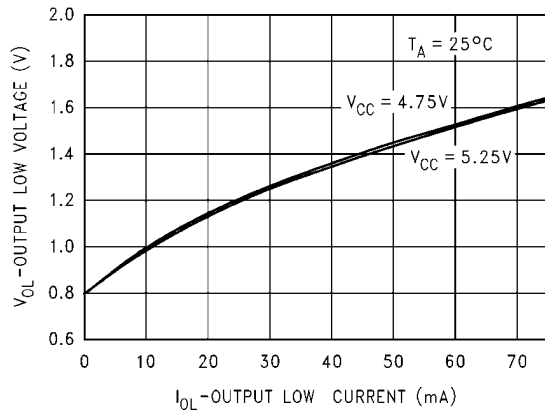

1138426

Driver V_{OL} vs I_{OL} vs Temperature

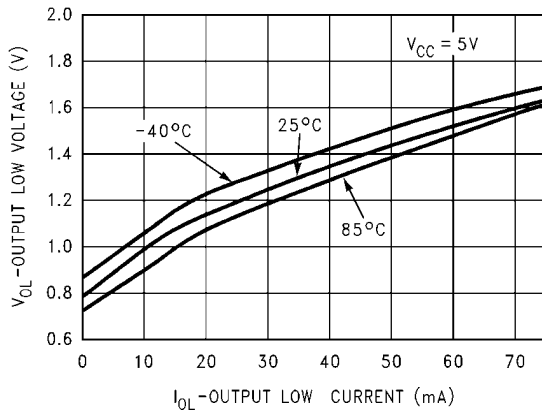

1138427

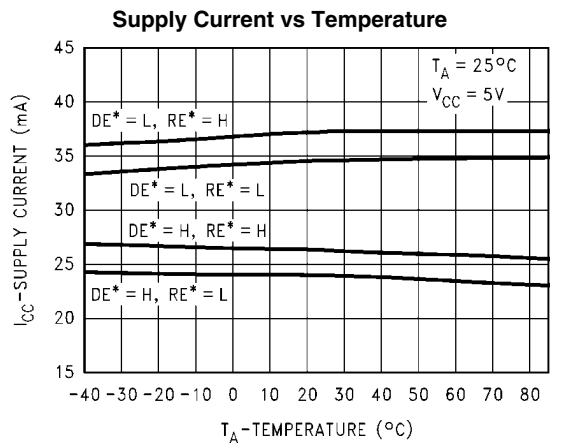
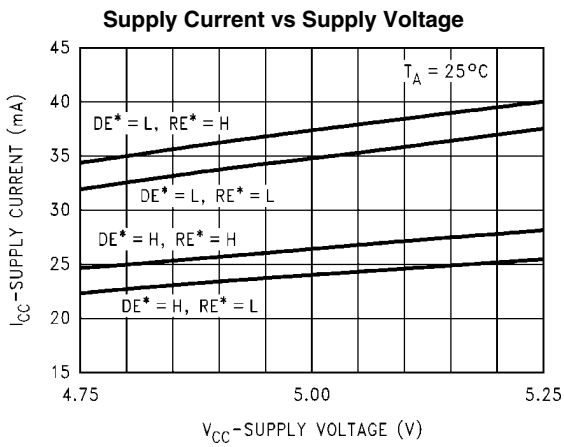
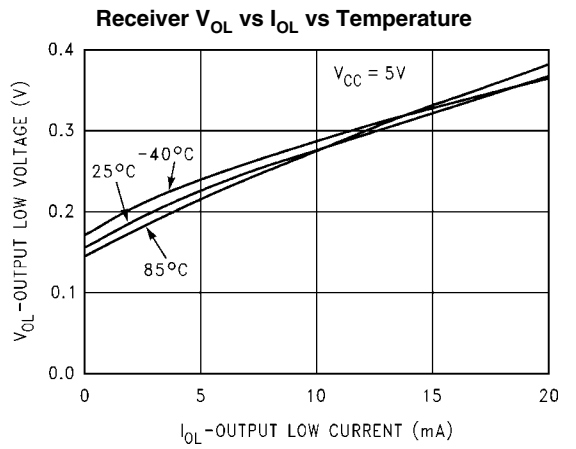
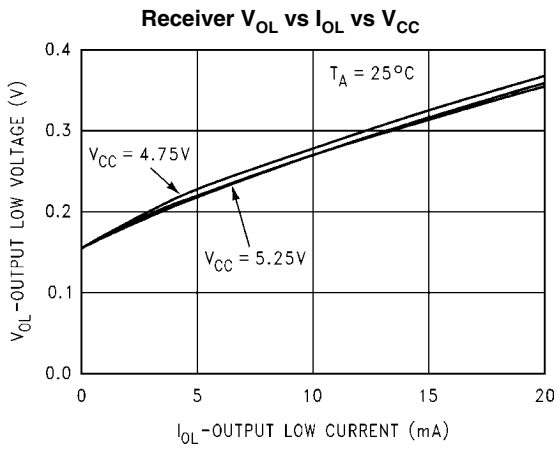
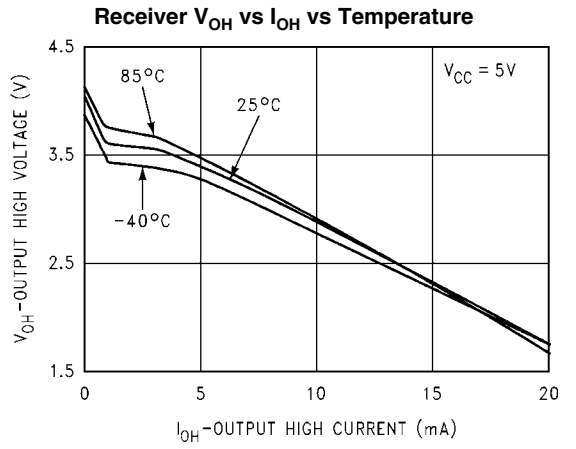
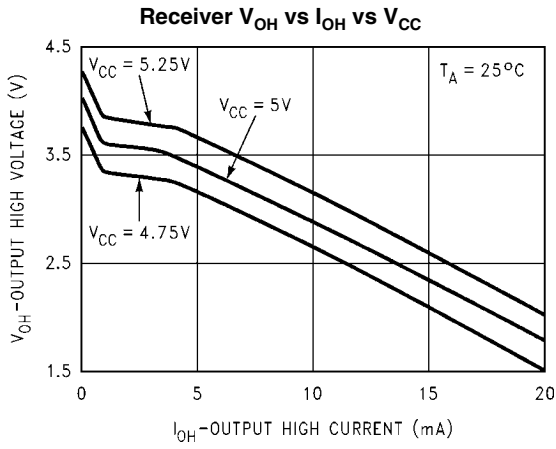

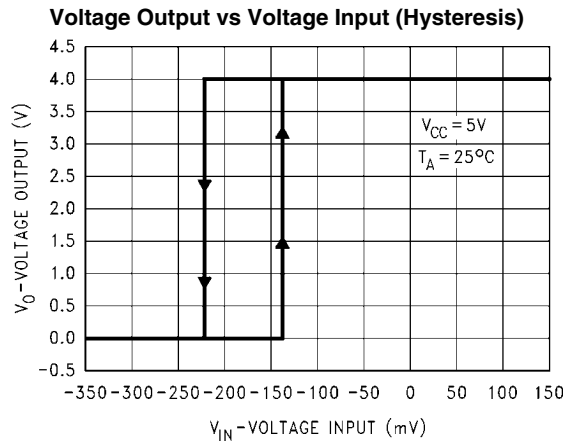

1138434

Typical Applications Information

SAE J1708 Node with External Bias Resistors and Filters

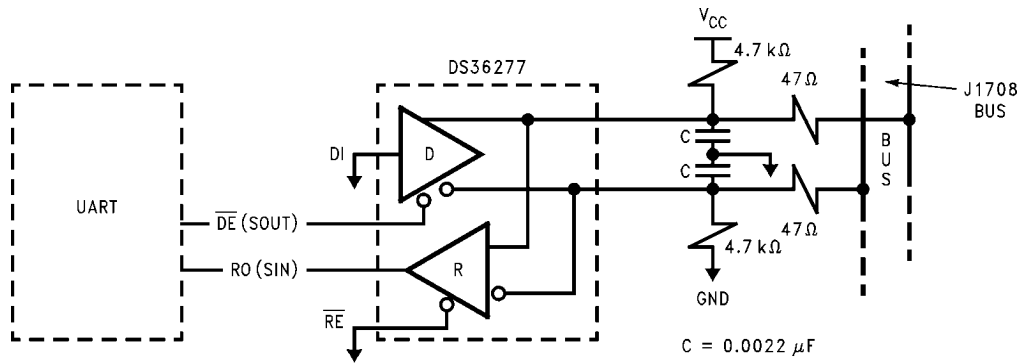

1138421

Physical Dimensions inches (millimeters) unless otherwise noted

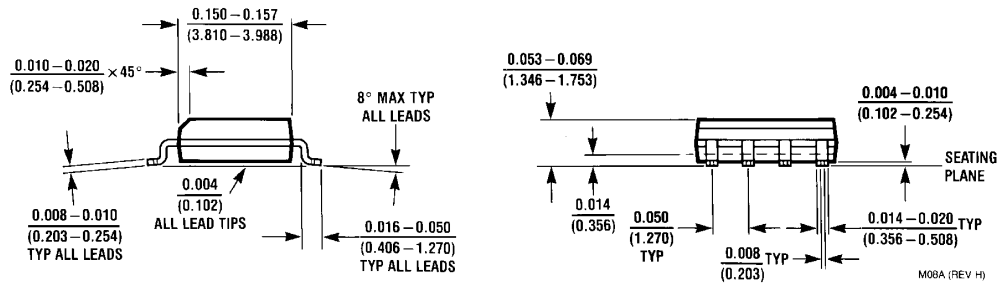
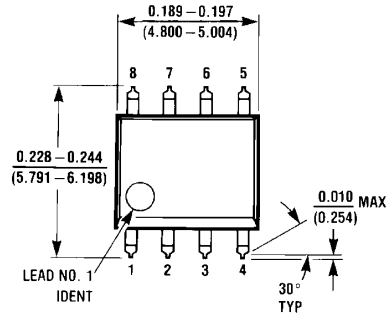

8-Lead Molded Package (SO)
Order Number DS36277TM
NS Package Number M08A

M08A (REV H)

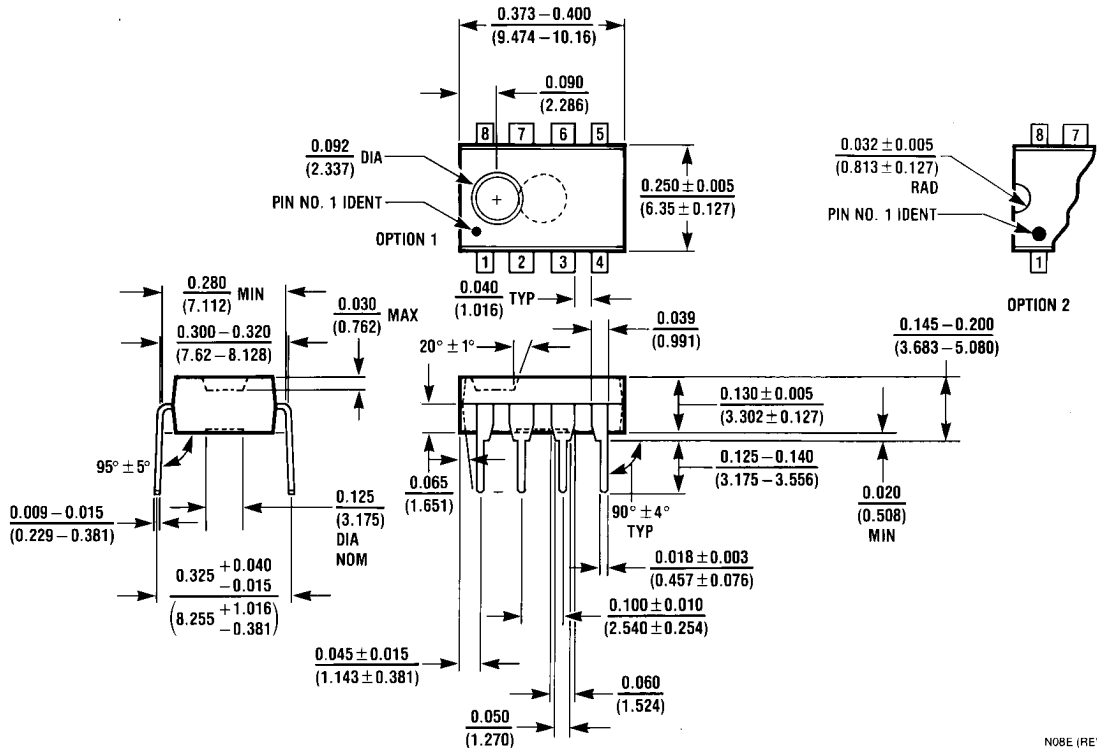

8-Lead Molded Dual-In-Line Package (N)
Order Number DS36277TN
NS Package Number N08E

N08E (REV F)

Notes

DS36277

Notes

For more National Semiconductor product information and proven design tools, visit the following Web sites at:

Products		Design Support	
Amplifiers	www.national.com/amplifiers	WEBENCH	www.national.com/webench
Audio	www.national.com/audio	Analog University	www.national.com/AU
Clock Conditioners	www.national.com/timing	App Notes	www.national.com/appnotes
Data Converters	www.national.com/adc	Distributors	www.national.com/contacts
Displays	www.national.com/displays	Green Compliance	www.national.com/quality/green
Ethernet	www.national.com/ethernet	Packaging	www.national.com/packaging
Interface	www.national.com/interface	Quality and Reliability	www.national.com/quality
LVDS	www.national.com/lvds	Reference Designs	www.national.com/refdesigns
Power Management	www.national.com/power	Feedback	www.national.com/feedback
Switching Regulators	www.national.com/switchers		
LDOs	www.national.com/lido		
LED Lighting	www.national.com/led		
PowerWise	www.national.com/powerwise		
Serial Digital Interface (SDI)	www.national.com/sdi		
Temperature Sensors	www.national.com/tempsensors		
Wireless (PLL/VCO)	www.national.com/wireless		

THE CONTENTS OF THIS DOCUMENT ARE PROVIDED IN CONNECTION WITH NATIONAL SEMICONDUCTOR CORPORATION ("NATIONAL") PRODUCTS. NATIONAL MAKES NO REPRESENTATIONS OR WARRANTIES WITH RESPECT TO THE ACCURACY OR COMPLETENESS OF THE CONTENTS OF THIS PUBLICATION AND RESERVES THE RIGHT TO MAKE CHANGES TO SPECIFICATIONS AND PRODUCT DESCRIPTIONS AT ANY TIME WITHOUT NOTICE. NO LICENSE, WHETHER EXPRESS, IMPLIED, ARISING BY ESTOPPEL OR OTHERWISE, TO ANY INTELLECTUAL PROPERTY RIGHTS IS GRANTED BY THIS DOCUMENT.

TESTING AND OTHER QUALITY CONTROLS ARE USED TO THE EXTENT NATIONAL DEEMS NECESSARY TO SUPPORT NATIONAL'S PRODUCT WARRANTY. EXCEPT WHERE MANDATED BY GOVERNMENT REQUIREMENTS, TESTING OF ALL PARAMETERS OF EACH PRODUCT IS NOT NECESSARILY PERFORMED. NATIONAL ASSUMES NO LIABILITY FOR APPLICATIONS ASSISTANCE OR BUYER PRODUCT DESIGN. BUYERS ARE RESPONSIBLE FOR THEIR PRODUCTS AND APPLICATIONS USING NATIONAL COMPONENTS. PRIOR TO USING OR DISTRIBUTING ANY PRODUCTS THAT INCLUDE NATIONAL COMPONENTS, BUYERS SHOULD PROVIDE ADEQUATE DESIGN, TESTING AND OPERATING SAFEGUARDS.

EXCEPT AS PROVIDED IN NATIONAL'S TERMS AND CONDITIONS OF SALE FOR SUCH PRODUCTS, NATIONAL ASSUMES NO LIABILITY WHATSOEVER, AND NATIONAL DISCLAIMS ANY EXPRESS OR IMPLIED WARRANTY RELATING TO THE SALE AND/OR USE OF NATIONAL PRODUCTS INCLUDING LIABILITY OR WARRANTIES RELATING TO FITNESS FOR A PARTICULAR PURPOSE, MERCHANTABILITY, OR INFRINGEMENT OF ANY PATENT, COPYRIGHT OR OTHER INTELLECTUAL PROPERTY RIGHT.

LIFE SUPPORT POLICY

NATIONAL'S PRODUCTS ARE NOT AUTHORIZED FOR USE AS CRITICAL COMPONENTS IN LIFE SUPPORT DEVICES OR SYSTEMS WITHOUT THE EXPRESS PRIOR WRITTEN APPROVAL OF THE CHIEF EXECUTIVE OFFICER AND GENERAL COUNSEL OF NATIONAL SEMICONDUCTOR CORPORATION. As used herein:

Life support devices or systems are devices which (a) are intended for surgical implant into the body, or (b) support or sustain life and whose failure to perform when properly used in accordance with instructions for use provided in the labeling can be reasonably expected to result in a significant injury to the user. A critical component is any component in a life support device or system whose failure to perform can be reasonably expected to cause the failure of the life support device or system or to affect its safety or effectiveness.

National Semiconductor and the National Semiconductor logo are registered trademarks of National Semiconductor Corporation. All other brand or product names may be trademarks or registered trademarks of their respective holders.

Copyright© 2008 National Semiconductor Corporation

For the most current product information visit us at www.national.com



**National Semiconductor
Americas Technical
Support Center**
Email: support@nsc.com
Tel: 1-800-272-9959

**National Semiconductor Europe
Technical Support Center**
Email: europe.support@nsc.com
German Tel: +49 (0) 180 5010 771
English Tel: +44 (0) 870 850 4288

**National Semiconductor Asia
Pacific Technical Support Center**
Email: ap.support@nsc.com

**National Semiconductor Japan
Technical Support Center**
Email: jpn.feedback@nsc.com