

DS90LV004

DS90LV004 4-Channel LVDS Buffer/Repeater with Pre-Emphasis



Literature Number: SNLS1900

DS90LV004

4-Channel LVDS Buffer/Repeater with Pre-Emphasis

General Description

The DS90LV004 is a four channel 1.5 Gbps LVDS buffer/repeater. High speed data paths and flow-through pinout minimize internal device jitter and simplify board layout, while configurable pre-emphasis overcomes ISI jitter effects from lossy backplanes and cables. The differential inputs interface to LVDS, and Bus LVDS signals such as those on National's 10-, 16-, and 18-bit Bus LVDS SerDes, as well as CML and LVPECL. The differential inputs and outputs are internally terminated with a 100Ω resistor to improve performance and minimize board space. The repeater function is especially useful for boosting signals for longer distance transmission over lossy cables and backplanes.

Features

- 1.5 Gbps data rate per channel
- Configurable pre-emphasis drives lossy backplanes and cables
- Low output skew and jitter
- LVDS/CML/LVPECL compatible input, LVDS output
- On-chip 100Ω input and output termination
- 12 kV ESD protection on LVDS outputs
- Single 3.3V supply
- Very low power consumption
- Industrial -40 to +85°C temperature range
- Small TQFP Package Footprint
- Evaluation Kit Available
- See SCAN90004 for JTAG-enabled version

Typical Application

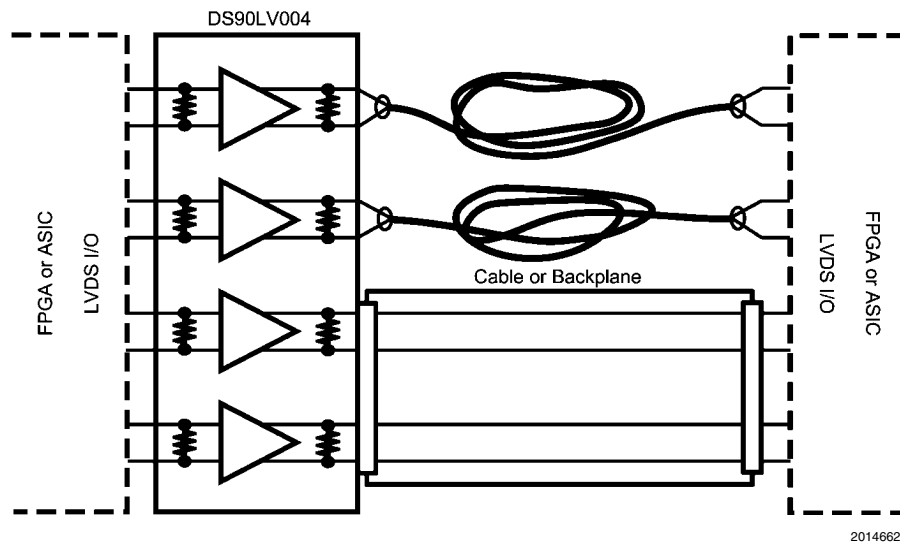

Block and Connection Diagrams

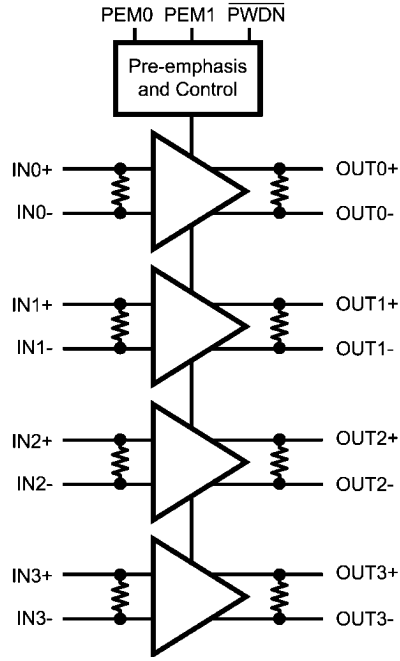

DS90LV004 Block Diagram

20146601

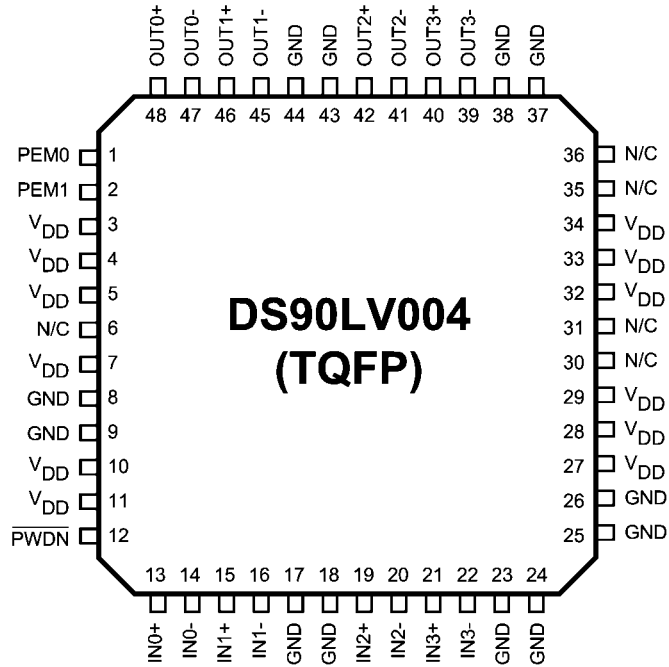

TQFP Pinout - Top View

20146602

Pin Descriptions

Pin Name	TQFP Pin Number	I/O, Type	Description
DIFFERENTIAL INPUTS			
IN0+	13	I, LVDS	Channel 0 inverting and non-inverting differential inputs.
IN0-	14		
IN1+	15	I, LVDS	Channel 1 inverting and non-inverting differential inputs.
IN1-	16		
IN2+	19	I, LVDS	Channel 2 inverting and non-inverting differential inputs.
IN2-	20		
IN3+	21	I, LVDS	Channel 3 inverting and non-inverting differential inputs.
IN3-	22		
DIFFERENTIAL OUTPUTS			
OUT0+	48	O, LVDS	Channel 0 inverting and non-inverting differential outputs. (Note 1)
OUT0-	47		
OUT1+	46	O, LVDS	Channel 1 inverting and non-inverting differential outputs. (Note 1)
OUT1-	45		
OUT2+	42	O, LVDS	Channel 2 inverting and non-inverting differential outputs. (Note 1)
OUT2-	41		
OUT3+	40	O, LVDS	Channel 3 inverting and non-inverting differential outputs. (Note 1)
OUT3-	39		
DIGITAL CONTROL INTERFACE			
PWDN	12	I, LVTTTL	A logic low at $\overline{\text{PWDN}}$ activates the hardware power down mode.
PEM0	1	I, LVTTTL	Pre-emphasis Control Inputs (affects all Channels)
PEM1	2		
POWER			
V _{DD}	3, 4, 5, 7, 10, 11, 27, 28, 29, 32, 33, 34	I, Power	V _{DD} = 3.3V, ±5%
GND	8, 9, 17, 18, 23, 24, 25, 26, 37, 38, 43, 44	I, Power	Ground reference for LVDS and CMOS circuitry.
N/C	6, 30, 31, 35, 36		No Connect

Note 1: The LVDS outputs do not support a multidrop (BLVDS) environment. The LVDS output characteristics of the DS90LV004 device have been optimized for point-to-point backplane and cable applications.

Absolute Maximum Ratings (Note 2)

Supply Voltage (V_{DD})	-0.3V to +4.0V
CMOS Input Voltage	-0.3V to ($V_{DD}+0.3V$)
LVDS Input Voltage (Note 3)	-0.3V to ($V_{DD}+0.3V$)
LVDS Output Voltage	-0.3V to ($V_{DD}+0.3V$)
LVDS Output Short Circuit Current	-90 mA
Junction Temperature	+150°C
Storage Temperature	-65°C to +150°C
Lead Temperature (Solder, 4sec)	260°C
Max Pkg Power Capacity @ 25°C	1.64W
Thermal Resistance (θ_{JA})	76°C/W
Package Derating above +25°C	13.2mW/°C
ESD Last Passing Voltage (LVDS Output pins)	
HBM, 1.5k Ω , 100pF	12 kV
EIAJ, 0 Ω , 200pF	250V
Charged Device Model	1000V

ESD Last Passing Voltage (All other pins)

HBM, 1.5k Ω , 100pF	8 kV
EIAJ, 0 Ω , 200pF	250V
Charged Device Model	1000

Recommended Operating Conditions

Supply Voltage (V_{CC})	3.15V to 3.45V
Input Voltage (V_i) (Note 3)	0V to V_{CC}
Output Voltage (V_o)	0V to V_{CC}
Operating Temperature (T_A)	
Industrial	-40°C to +85°C

Note 2: Absolute maximum ratings are those values beyond which damage to the device may occur. The databook specifications should be met, without exception, to ensure that the system design is reliable over its power supply, temperature, and output/input loading variables. National does not recommend operation of products outside of recommended operation conditions.

Note 3: V_{ID} max < 2.4V

Electrical Characteristics

Over recommended operating supply and temperature ranges unless other specified.

Symbol	Parameter	Conditions	Min	Typ (Note 4)	Max	Units
LVTTL DC SPECIFICATIONS (PWDN, PEM0, PEM1)						
V_{IH}	High Level Input Voltage		2.0		V_{DD}	V
V_{IL}	Low Level Input Voltage		GND		0.8	V
I_{IH}	High Level Input Current	$V_{IN} = V_{DD} = V_{DDMAX}$	-10		+10	μ A
I_{IL}	Low Level Input Current	$V_{IN} = V_{SS}, V_{DD} = V_{DDMAX}$	-10		+10	μ A
C_{IN1}	Input Capacitance	Any Digital Input Pin to V_{SS}		3.5		pF
V_{CL}	Input Clamp Voltage	$I_{CL} = -18$ mA	-1.5	-0.8		V
LVDS INPUT DC SPECIFICATIONS (INn\pm)						
V_{TH}	Differential Input High Threshold (Note 5)	$V_{CM} = 0.8V$ to 3.4V, $V_{DD} = 3.45V$		0	100	mV
V_{TL}	Differential Input Low Threshold (Note 5)	$V_{CM} = 0.8V$ to 3.4V, $V_{DD} = 3.45V$	-100	0		mV
V_{ID}	Differential Input Voltage	$V_{CM} = 0.8V$ to 3.4V, $V_{DD} = 3.45V$	100		2400	mV
V_{CMR}	Common Mode Voltage Range	$V_{ID} = 150$ mV, $V_{DD} = 3.45V$	0.05		3.40	V
C_{IN2}	Input Capacitance	IN+ or IN- to V_{SS}		3.5		pF
I_{IN}	Input Current	$V_{IN} = 3.45V, V_{DD} = V_{DDMAX}$	-10		+10	μ A
		$V_{IN} = 0V, V_{DD} = V_{DDMAX}$	-10		+10	μ A

Symbol	Parameter	Conditions	Min	Typ (Note 4)	Max	Units
LVDS OUTPUT DC SPECIFICATIONS (OUT_{n±})						
V _{OD}	Differential Output Voltage, 0% Pre-emphasis (Note 5)	R _L = 100Ω external resistor between OUT+ and OUT-	250	500	600	mV
ΔV _{OD}	Change in V _{OD} between Complementary States		-35		35	mV
V _{OS}	Offset Voltage (Note 6)		1.05	1.18	1.475	V
ΔV _{OS}	Change in V _{OS} between Complementary States		-35		35	mV
I _{OS}	Output Short Circuit Current	OUT+ or OUT- Short to GND		-60	-90	mA
C _{OUT2}	Output Capacitance	OUT+ or OUT- to GND when TRI-STATE®		5.5		pF
SUPPLY CURRENT (Static)						
I _{CC}	Supply Current	All inputs and outputs enabled and active, terminated with differential load of 100Ω between OUT+ and OUT-, 0% pre-emphasis		117	140	mA
I _{CCZ}	Supply Current - Power Down Mode	PWDN = L, 0% pre-emphasis		2.7	6	mA
SWITCHING CHARACTERISTICS—LVDS OUTPUTS						
t _{LHT}	Differential Low to High Transition Time	Use an alternating 1 and 0 pattern at 200 Mbps, measure between 20% and 80% of V _{OD} . (Note 11)		210	300	ps
t _{HLT}	Differential High to Low Transition Time			210	300	ps
t _{PLHD}	Differential Low to High Propagation Delay	Use an alternating 1 and 0 pattern at 200 Mbps, measure at 50% V _{OD} between input to output.		2.0	3.2	ns
t _{PHLD}	Differential High to Low Propagation Delay			2.0	3.2	ns
t _{SKD1}	Pulse Skew	t _{PLHD} - t _{PHLD} (Note 11)		25	80	ps
t _{SKCC}	Output Channel to Channel Skew	Difference in propagation delay (t _{PLHD} or t _{PHLD}) among all output channels. (Note 11)		50	125	ps
t _{SKP}	Part to Part Skew	Common Edge, parts at same temp and V _{CC} (Note 11)			1.1	ns
t _{JIT}	Jitter (0% Pre-emphasis) (Note 7)	RJ - Alternating 1 and 0 at 750 MHz (Note 8)		1.1	1.5	psrms
		DJ - K28.5 Pattern, 1.5 Gbps (Note 9)		43	62	psp-p
		TJ - PRBS 2 ²³ -1 Pattern, 1.5 Gbps (Note 10)		35	85	psp-p
t _{ON}	LVDS Output Enable Time	Time from PWDN to OUT± change from TRI-STATE to active.			300	ns
t _{OFF}	LVDS Output Disable Time	Time from PWDN to OUT± change from active to TRI-STATE.			12	ns

Note 4: Typical parameters are measured at V_{DD} = 3.3V, T_A = 25°C. They are for reference purposes, and are not production-tested.

Note 5: Differential output voltage V_{OD} is defined as ABS(OUT+ - OUT-). Differential input voltage V_{ID} is defined as ABS(IN+ - IN-).

Note 6: Output offset voltage V_{OS} is defined as the average of the LVDS single-ended output voltages at logic high and logic low states.

Note 7: Jitter is not production tested, but guaranteed through characterization on a sample basis.

Note 8: Random Jitter, or RJ, is measured RMS with a histogram including 1500 histogram window hits. The input voltage = V_{ID} = 500mV, 50% duty cycle at 750MHz, t_r = t_f = 50ps (20% to 80%).

Note 9: Deterministic Jitter, or DJ, is measured to a histogram mean with a sample size of 350 hits. The input voltage = V_{ID} = 500mV, K28.5 pattern at 1.5 Gbps, t_r = t_f = 50ps (20% to 80%). The K28.5 pattern is repeating bit streams of (0011111010 1100000101).

Note 10: Total Jitter, or TJ, is measured peak to peak with a histogram including 3500 window hits. Stimulus and fixture Jitter has been subtracted. The input voltage = V_{ID} = 500mV, 2²³-1 PRBS pattern at 1.5 Gbps, t_r = t_f = 50ps (20% to 80%).

Note 11: Not production tested. Guaranteed by a statistical analysis on a sample basis at the time of characterization.

Feature Descriptions

INTERNAL TERMINATIONS

The DS90LV004 has integrated termination resistors on both the input and outputs. The inputs have a 100Ω resistor across the differential pair, placing the receiver termination as close as possible to the input stage of the device. The LVDS outputs also contain an integrated 100Ω ohm termination resistor, this resistor is used to reduce the effects of Near End Crosstalk (NEXT) and does not take the place of the 100 ohm termination at the inputs to the receiving device. The integrated terminations improve signal integrity and decrease the external component count resulting in space savings.

OUTPUT CHARACTERISTICS

The output characteristics of the DS90LV004 have been optimized for point-to-point backplane and cable applications, and are not intended for multipoint or multidrop signaling.

POWERDOWN MODE

The $\overline{\text{PWN}}$ input activates a hardware powerdown mode. When the powerdown mode is active ($\overline{\text{PWN}}=\text{L}$), all input and output buffers and internal bias circuitry are powered off and disabled. Outputs are tri-stated in powerdown mode. When exiting powerdown mode, there is a delay associated with turning on bandgap references and input/output buffer circuits as indicated in the LVDS Output Switching Characteristics

PRE-EMPHASIS

Pre-emphasis dramatically reduces ISI jitter from long or lossy transmission media. Two pins are used to select the pre-emphasis level for all outputs: off, low, medium, or high.

Pre-Emphasis Control Selection Table

PEM1	PEM0	Pre-Emphasis
0	0	Off
0	1	Low
1	0	Medium
1	1	High

INPUT FAILSAFE BIASING

External pull up and pull down resistors may be used to provide enough of an offset to enable an input failsafe under open-circuit conditions. This configuration ties the positive LVDS input pin to V_{DD} thru a pull up resistor and the negative LVDS input pin is tied to GND by a pull down resistor. The pull up and pull down resistors should be in the 5kΩ to 15kΩ range to minimize loading and waveform distortion to the driver. The common-mode bias point ideally should be set to approximately 1.2V (less than 1.75V) to be compatible with the internal circuitry. Please refer to application note AN-1194 "Failsafe Biasing of LVDS Interfaces" for more information.

INPUT INTERFACING

The DS90LV004 accepts differential signals and allow simple AC or DC coupling. With a wide common mode range, the DS90LV004 can be DC-coupled with all common differential

drivers (i.e. LVPECL, LVDS, CML). The following three figures illustrate typical DC-coupled interface to common differential drivers. Note that the DS90LV004 inputs are internally terminated with a 100Ω resistor.

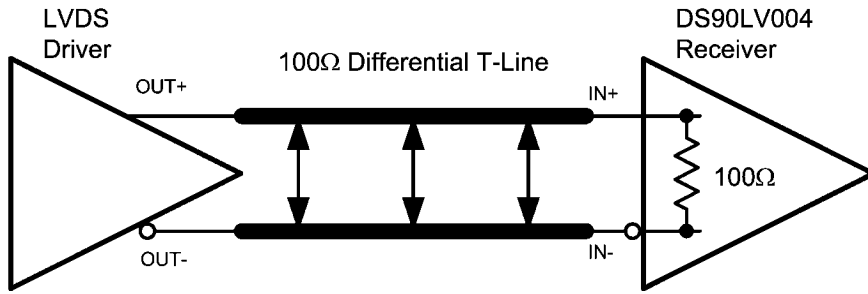

Typical LVDS Driver DC-Coupled Interface to DS90LV004 Input

20146631

CML3.3V or CML2.5V Driver

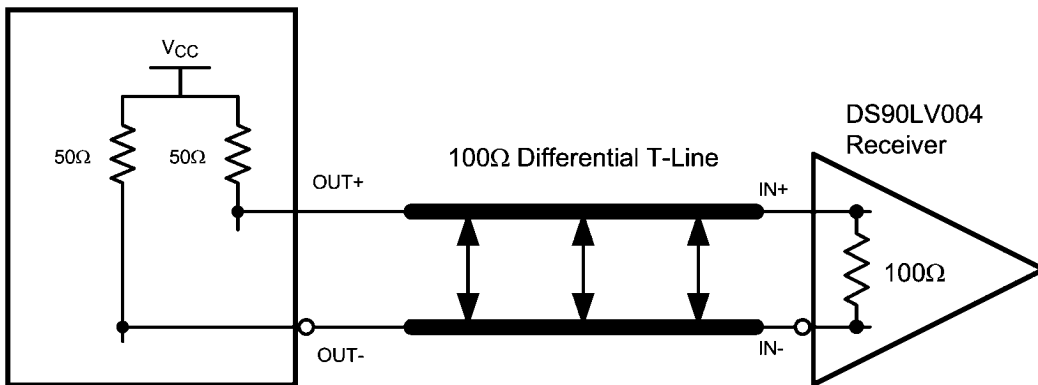

Typical CML Driver DC-Coupled Interface to DS90LV004 Input

20146632

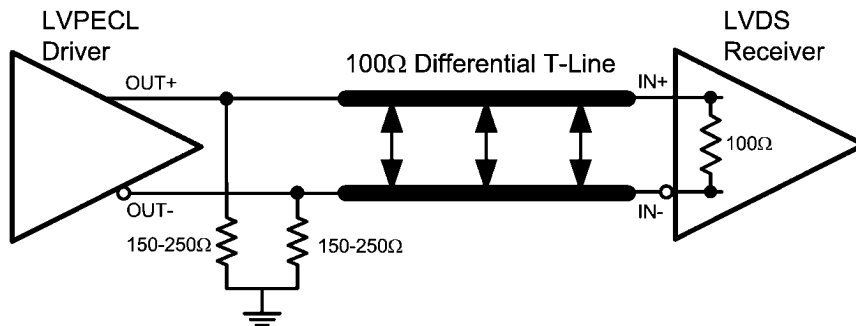

Typical LVPECL Driver DC-Coupled Interface to DS90LV004 Input

20146633

OUTPUT INTERFACING

The DS90LV004 outputs signals that are compliant to the LVDS standard. Their outputs can be DC-coupled to most common differential receivers. The following figure illustrates typical DC-coupled interface to common differential receivers

and assumes that the receivers have high impedance inputs. While most differential receivers have a common mode input range that can accommodate LVDS compliant signals, it is recommended to check respective receiver's data sheet prior to implementing the suggested interface implementation.

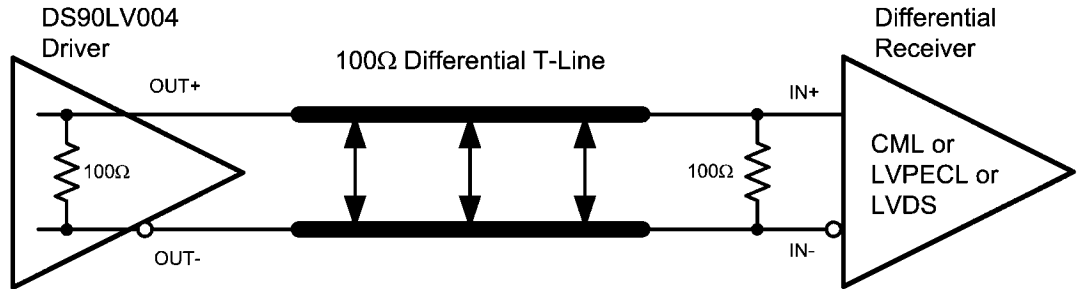

Typical DS90LV004 Output DC-Coupled Interface to an LVDS, CML or LVPECL Receiver

20146634

Typical Performance Characteristics

Power Supply Current vs. Bit Data Rate

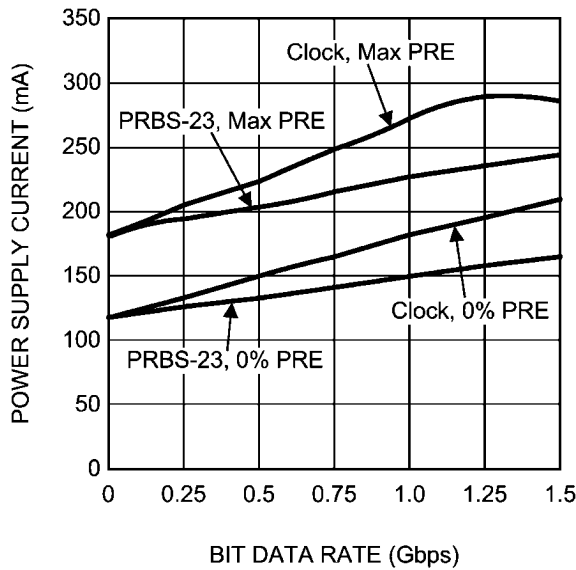

Total Jitter (T_j) vs. Bit Data Rate

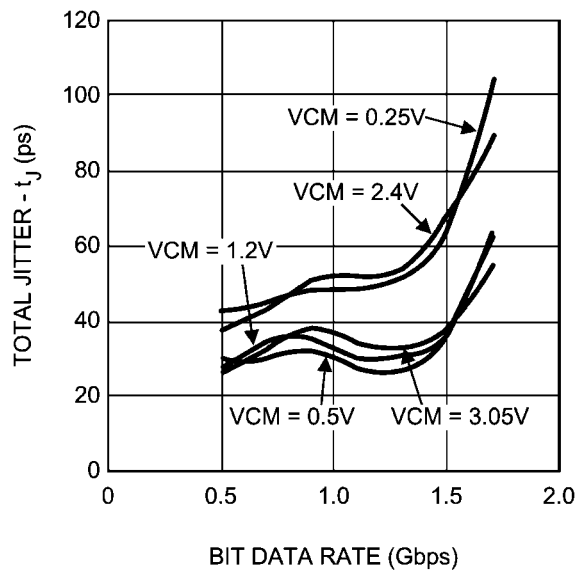

Dynamic power supply current was measured while running a clock or PRBS Total Jitter measured at 0V differential while running a PRBS 2²³-1 pattern with all 4 channels active. $V_{CC} = 3.3V$, $T_A = +25^\circ C$, $V_{ID} = 0.5V$, a single channel active. $V_{CC} = 3.3V$, $T_A = +25^\circ C$, $V_{ID} = 0.5V$, 0% Pre-emphasis $V_{CM} = 1.2V$

Total Jitter (T_j) vs. Temperature

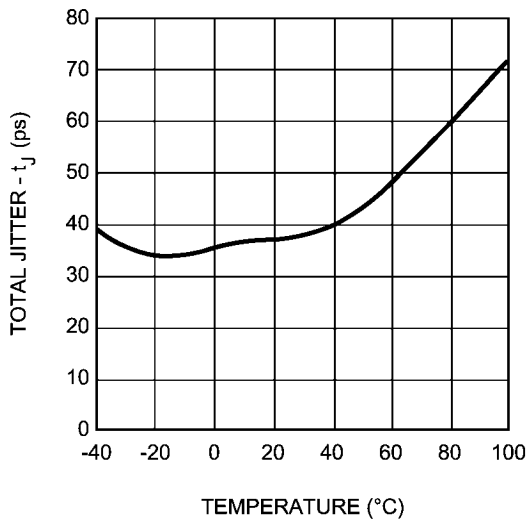

Positive Edge Transition vs. Pre-Emphasis Level

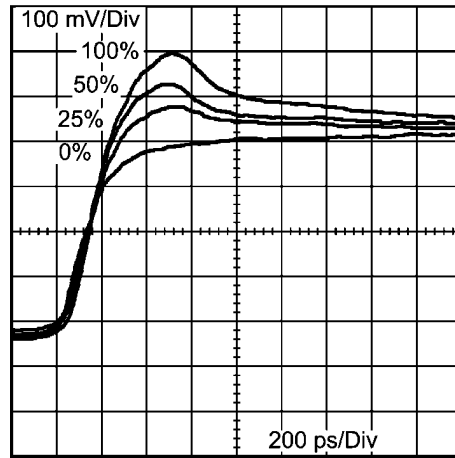

Total Jitter measured at 0V differential while running a PRBS 2²³-1 pattern with a single channel active. $V_{CC} = 3.3V$, $V_{ID} = 0.5V$, $V_{CM} = 1.2V$, 1.5 Gbps data rate, 0% Pre-emphasis

Physical Dimensions inches (millimeters) unless otherwise noted

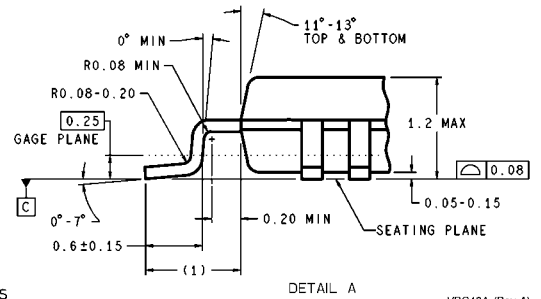
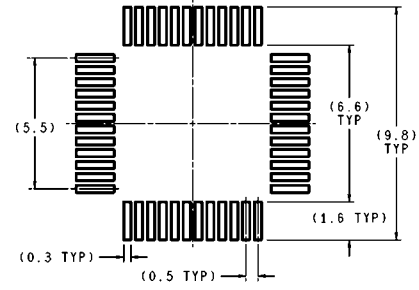
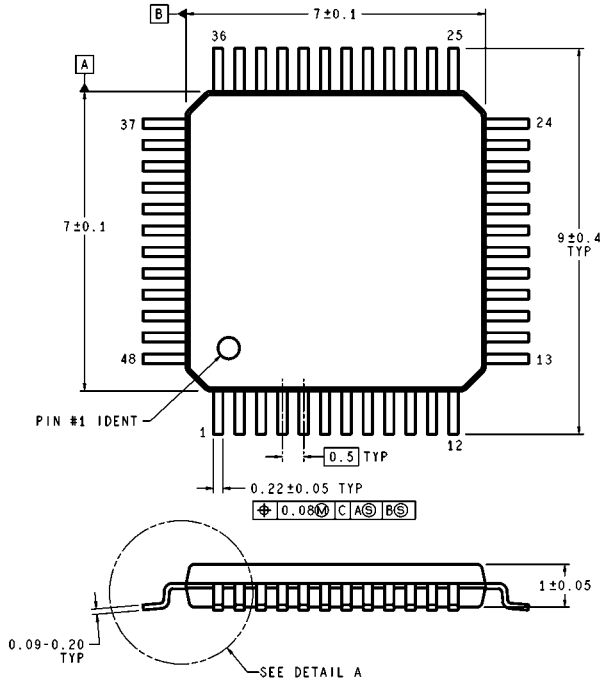

DIMENSIONS ARE IN MILLIMETERS

48-TQFP
NS Package Number VBC48a
Order Number DS90LV004TVS (250 piece Tray)

VBC48A (Rev A)

Notes

Notes

For more National Semiconductor product information and proven design tools, visit the following Web sites at:

Products		Design Support	
Amplifiers	www.national.com/amplifiers	WEBENCH® Tools	www.national.com/webench
Audio	www.national.com/audio	App Notes	www.national.com/appnotes
Clock and Timing	www.national.com/timing	Reference Designs	www.national.com/refdesigns
Data Converters	www.national.com/adc	Samples	www.national.com/samples
Interface	www.national.com/interface	Eval Boards	www.national.com/evalboards
LVDS	www.national.com/lvds	Packaging	www.national.com/packaging
Power Management	www.national.com/power	Green Compliance	www.national.com/quality/green
Switching Regulators	www.national.com/switchers	Distributors	www.national.com/contacts
LDOs	www.national.com/ldo	Quality and Reliability	www.national.com/quality
LED Lighting	www.national.com/led	Feedback/Support	www.national.com/feedback
Voltage Reference	www.national.com/vref	Design Made Easy	www.national.com/easy
PowerWise® Solutions	www.national.com/powerwise	Solutions	www.national.com/solutions
Serial Digital Interface (SDI)	www.national.com/sdi	Mil/Aero	www.national.com/milaero
Temperature Sensors	www.national.com/tempsensors	SolarMagic™	www.national.com/solarmagic
Wireless (PLL/VCO)	www.national.com/wireless	Analog University®	www.national.com/AU

THE CONTENTS OF THIS DOCUMENT ARE PROVIDED IN CONNECTION WITH NATIONAL SEMICONDUCTOR CORPORATION ("NATIONAL") PRODUCTS. NATIONAL MAKES NO REPRESENTATIONS OR WARRANTIES WITH RESPECT TO THE ACCURACY OR COMPLETENESS OF THE CONTENTS OF THIS PUBLICATION AND RESERVES THE RIGHT TO MAKE CHANGES TO SPECIFICATIONS AND PRODUCT DESCRIPTIONS AT ANY TIME WITHOUT NOTICE. NO LICENSE, WHETHER EXPRESS, IMPLIED, ARISING BY ESTOPPEL OR OTHERWISE, TO ANY INTELLECTUAL PROPERTY RIGHTS IS GRANTED BY THIS DOCUMENT.

TESTING AND OTHER QUALITY CONTROLS ARE USED TO THE EXTENT NATIONAL DEEMS NECESSARY TO SUPPORT NATIONAL'S PRODUCT WARRANTY. EXCEPT WHERE MANDATED BY GOVERNMENT REQUIREMENTS, TESTING OF ALL PARAMETERS OF EACH PRODUCT IS NOT NECESSARILY PERFORMED. NATIONAL ASSUMES NO LIABILITY FOR APPLICATIONS ASSISTANCE OR BUYER PRODUCT DESIGN. BUYERS ARE RESPONSIBLE FOR THEIR PRODUCTS AND APPLICATIONS USING NATIONAL COMPONENTS. PRIOR TO USING OR DISTRIBUTING ANY PRODUCTS THAT INCLUDE NATIONAL COMPONENTS, BUYERS SHOULD PROVIDE ADEQUATE DESIGN, TESTING AND OPERATING SAFEGUARDS.

EXCEPT AS PROVIDED IN NATIONAL'S TERMS AND CONDITIONS OF SALE FOR SUCH PRODUCTS, NATIONAL ASSUMES NO LIABILITY WHATSOEVER, AND NATIONAL DISCLAIMS ANY EXPRESS OR IMPLIED WARRANTY RELATING TO THE SALE AND/OR USE OF NATIONAL PRODUCTS INCLUDING LIABILITY OR WARRANTIES RELATING TO FITNESS FOR A PARTICULAR PURPOSE, MERCHANTABILITY, OR INFRINGEMENT OF ANY PATENT, COPYRIGHT OR OTHER INTELLECTUAL PROPERTY RIGHT.

LIFE SUPPORT POLICY

NATIONAL'S PRODUCTS ARE NOT AUTHORIZED FOR USE AS CRITICAL COMPONENTS IN LIFE SUPPORT DEVICES OR SYSTEMS WITHOUT THE EXPRESS PRIOR WRITTEN APPROVAL OF THE CHIEF EXECUTIVE OFFICER AND GENERAL COUNSEL OF NATIONAL SEMICONDUCTOR CORPORATION. As used herein:

Life support devices or systems are devices which (a) are intended for surgical implant into the body, or (b) support or sustain life and whose failure to perform when properly used in accordance with instructions for use provided in the labeling can be reasonably expected to result in a significant injury to the user. A critical component is any component in a life support device or system whose failure to perform can be reasonably expected to cause the failure of the life support device or system or to affect its safety or effectiveness.

National Semiconductor and the National Semiconductor logo are registered trademarks of National Semiconductor Corporation. All other brand or product names may be trademarks or registered trademarks of their respective holders.

Copyright© 2009 National Semiconductor Corporation

For the most current product information visit us at www.national.com



National Semiconductor Americas Technical Support Center
 Email: support@nsc.com
 Tel: 1-800-272-9959

National Semiconductor Europe Technical Support Center
 Email: europe.support@nsc.com

National Semiconductor Asia Pacific Technical Support Center
 Email: ap.support@nsc.com

National Semiconductor Japan Technical Support Center
 Email: jpn.feedback@nsc.com

IMPORTANT NOTICE

Texas Instruments Incorporated and its subsidiaries (TI) reserve the right to make corrections, modifications, enhancements, improvements, and other changes to its products and services at any time and to discontinue any product or service without notice. Customers should obtain the latest relevant information before placing orders and should verify that such information is current and complete. All products are sold subject to TI's terms and conditions of sale supplied at the time of order acknowledgment.

TI warrants performance of its hardware products to the specifications applicable at the time of sale in accordance with TI's standard warranty. Testing and other quality control techniques are used to the extent TI deems necessary to support this warranty. Except where mandated by government requirements, testing of all parameters of each product is not necessarily performed.

TI assumes no liability for applications assistance or customer product design. Customers are responsible for their products and applications using TI components. To minimize the risks associated with customer products and applications, customers should provide adequate design and operating safeguards.

TI does not warrant or represent that any license, either express or implied, is granted under any TI patent right, copyright, mask work right, or other TI intellectual property right relating to any combination, machine, or process in which TI products or services are used. Information published by TI regarding third-party products or services does not constitute a license from TI to use such products or services or a warranty or endorsement thereof. Use of such information may require a license from a third party under the patents or other intellectual property of the third party, or a license from TI under the patents or other intellectual property of TI.

Reproduction of TI information in TI data books or data sheets is permissible only if reproduction is without alteration and is accompanied by all associated warranties, conditions, limitations, and notices. Reproduction of this information with alteration is an unfair and deceptive business practice. TI is not responsible or liable for such altered documentation. Information of third parties may be subject to additional restrictions.

Resale of TI products or services with statements different from or beyond the parameters stated by TI for that product or service voids all express and any implied warranties for the associated TI product or service and is an unfair and deceptive business practice. TI is not responsible or liable for any such statements.

TI products are not authorized for use in safety-critical applications (such as life support) where a failure of the TI product would reasonably be expected to cause severe personal injury or death, unless officers of the parties have executed an agreement specifically governing such use. Buyers represent that they have all necessary expertise in the safety and regulatory ramifications of their applications, and acknowledge and agree that they are solely responsible for all legal, regulatory and safety-related requirements concerning their products and any use of TI products in such safety-critical applications, notwithstanding any applications-related information or support that may be provided by TI. Further, Buyers must fully indemnify TI and its representatives against any damages arising out of the use of TI products in such safety-critical applications.

TI products are neither designed nor intended for use in military/aerospace applications or environments unless the TI products are specifically designated by TI as military-grade or "enhanced plastic." Only products designated by TI as military-grade meet military specifications. Buyers acknowledge and agree that any such use of TI products which TI has not designated as military-grade is solely at the Buyer's risk, and that they are solely responsible for compliance with all legal and regulatory requirements in connection with such use.

TI products are neither designed nor intended for use in automotive applications or environments unless the specific TI products are designated by TI as compliant with ISO/TS 16949 requirements. Buyers acknowledge and agree that, if they use any non-designated products in automotive applications, TI will not be responsible for any failure to meet such requirements.

Following are URLs where you can obtain information on other Texas Instruments products and application solutions:

Products

Audio	www.ti.com/audio
Amplifiers	amplifier.ti.com
Data Converters	dataconverter.ti.com
DLP® Products	www.dlp.com
DSP	dsp.ti.com
Clocks and Timers	www.ti.com/clocks
Interface	interface.ti.com
Logic	logic.ti.com
Power Mgmt	power.ti.com
Microcontrollers	microcontroller.ti.com
RFID	www.ti-rfid.com
OMAP Mobile Processors	www.ti.com/omap
Wireless Connectivity	www.ti.com/wirelessconnectivity

Applications

Communications and Telecom	www.ti.com/communications
Computers and Peripherals	www.ti.com/computers
Consumer Electronics	www.ti.com/consumer-apps
Energy and Lighting	www.ti.com/energy
Industrial	www.ti.com/industrial
Medical	www.ti.com/medical
Security	www.ti.com/security
Space, Avionics and Defense	www.ti.com/space-avionics-defense
Transportation and Automotive	www.ti.com/automotive
Video and Imaging	www.ti.com/video

TI E2E Community Home Page

e2e.ti.com

Mailing Address: Texas Instruments, Post Office Box 655303, Dallas, Texas 75265
Copyright © 2011, Texas Instruments Incorporated