

1 Ω SPDT Switch

NL5S4157A

The NL5S4157A is a low R_{ON} SPDT analog switch. The device is designed for low operating voltage, high current switching of speaker output for mobile applications. It can switch a balanced stereo output. It can handle a balanced microphone/speaker/ringtone generator in monophone mode.

Features

- Wide V_{CC} Operating Range: 1.65 V to 5.5 V
- OVT up to +5.5 V for Control pin
- R_{ON} : Typically $< 1 \Omega$ at $V_{CC} = 4.5 V$
- Rail-to-Rail Input/Output
- This Device is Pb-Free, Halogen Free/BFR Free and is RoHS Compliant

Typical Applications

- Cell Phone Speaker/Microphone Switching
- Ringtone-Chip/Amplifier Switching
- Stereo Balanced (Push-Pull) Switching
- RF PA Routing
- General Switching



ON Semiconductor®

www.onsemi.com



1

SC-88/SC70-6/SOT-363
CASE 419B-02

MARKING DIAGRAM

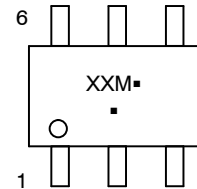

XX = Specific Device Code
M = Date Code*
■ = Pb-Free Package

(Note: Microdot may be in either location)

*Date Code orientation and/or position may vary depending upon manufacturing location.

ORDERING INFORMATION

See detailed ordering and shipping information on page 6 of this data sheet.

NL5S4157A

PIN ASSIGNMENTS

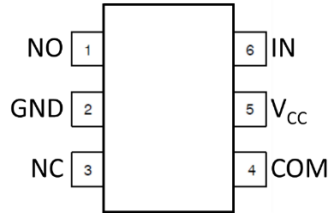

Figure 1. NL5S4157A (Top View)

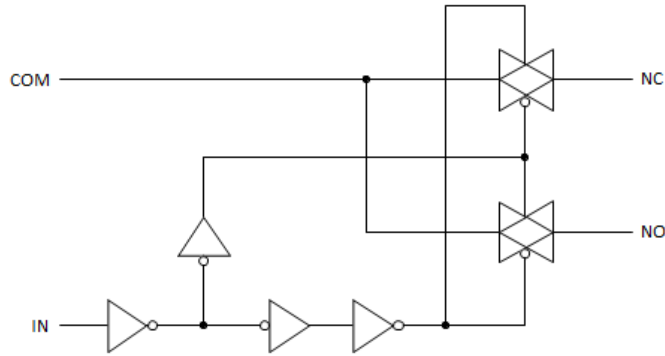

Figure 2. Analog Symbol

PIN DESCRIPTION

Pin	Name	Description
1	NO	Normally-Open Port
2	GND	Supply Ground
3	NC	Normally-Closed Port
4	COM	Common Port
5	V _{CC}	Supply
6	IN	Switch Select Input

FUNCTION TABLE

IN	Switch
L	NC to COM
H	NO to COM

NL5S4157A

MAXIMUM RATINGS

Symbol	Rating	Value	Unit
V_{CC}	Positive DC Supply Voltage	-0.5 to +6.0	V
V_{IS}	Switch Input / Output Voltage	-0.5 to $V_{CC}+0.5$	V
V_{IN}	Digital Select Input Voltage	-0.5 to +6.0	V
I_{OK}	I/O Port Diode Current	± 100	mA
I_{IK}	Select Input Diode Current	-100	mA
$I_{I/O}$	Continuous DC Current Through Analog Switch	± 100	mA
$I_{I/O-pk}$	Peak Current Through Analog Switch, 10% Duty Cycle	± 300	mA
T_s	Storage Temperature	-65 to +150	$^{\circ}C$
ESD	Human Body Model (HBM)	2	kV

Stresses exceeding those listed in the Maximum Ratings table may damage the device. If any of these limits are exceeded, device functionality should not be assumed, damage may occur and reliability may be affected.

RECOMMENDED OPERATING CONDITIONS

Symbol	Parameter	Min	Max	Unit	
V_{CC}	Positive DC Supply Voltage	1.65	5.5	V	
V_{IS}	Switch Input / Output Voltage	GND	V_{CC}	V	
V_{IN}	Digital Select Input Voltage	GND	5.5	V	
T_A	Operating Temperature Range	-40	+125	$^{\circ}C$	
t_r, t_f	Input Transition Rise or Fall Time (Select Input IN)	$V_{CC} \leq 3.0$ V	0	20	ns/V
		$V_{CC} > 3.0$ V	0	10	

Functional operation above the stresses listed in the Recommended Operating Ranges is not implied. Extended exposure to stresses beyond the Recommended Operating Ranges limits may affect device reliability.

NL5S4157A

ELECTRICAL CHARACTERISTICS

Symbol	Parameter	Condition	V _{CC} (V)	Guaranteed Limit						Unit	
				25°C			-40°C to 85°C		-40°C to 125°C		
				Min	Typ	Max	Min	Max	Min		Max
V _{IH}	Input High Voltage		2.7	1.1			1.1		1.1		V
			5.0	1.42			1.42		1.42		
V _{IL}	Input Low Voltage		2.7			0.4		0.4		0.4	V
			5.0			0.7		0.7		0.7	
I _{IN}	Input Leakage Current	V _{IN} = 0 V to 5.5 V	1.65 – 5.5			±0.1		±1		±1	µA
I _{OFF}	Input Leakage Current	V _{IN} = 0 to 5.5 V	0			0.05		1		1	µA
I _{S(ON)}	ON-State Switch Leakage Current	V _{IS} = GND to V _{CC} , V _{OS} = Open	5.5			±10		±200		±600	nA
I _{S(OFF)}	OFF-State Switch Leakage Current	V _{IS} = V _{CC} and V _{OS} = GND, or I _S = GND and V _{OS} = V _{CC}	5.5			±10		±200		±600	nA
I _{CC}	Quiescent Supply Current	V _{IN} = V _{CC} or GND, I _{OS} = 0 mA	5.5			0.5		5		5	µA

NL5S4157A

ANALOG SWITCH CHARACTERISTICS

Symbol	Parameter	Condition	V _{CC} (V)	Guaranteed Limit					Unit
				25°C			-40°C to 125°C		
				Min	Typ	Max	Min	Max	
R _{ON} (Note 1)	Switch ON Resistance	V _{IS} = 0 to V _{CC} , I _O = 100 mA	2.7		0.9	1.2		1.4	Ω
			4.5		0.6	0.8		1.0	
ΔR _{ON} (Notes 1, 2, 3)	ON Resistance Match	V _{IS} = 1.5 V, I _A = 100 mA	2.7		0.05	0.15		0.15	Ω
	Between Channels	V _{IS} = 2.5 V, I _A = 100 mA	4.5		0.04	0.12		0.15	
R _{FLAT} (Notes 1, 2, 4)	ON Resistance Flatness	V _{IS} = 0 to V _{CC} , I _O = 100 mA	2.7		0.3	0.4		0.4	Ω
			4.5		0.2	0.4		0.4	
Q (Note 5)	Charge Injection	C _L = 1 nF, V _{GEN} = 0 V,	2.7		38				pC
		R _{GEN} = 0 Ω	4.5		55				
V _{ISO} (Note 6)	Off-Isolation	R _L = 50 Ω, f = 1 MHz	2.7 – 5.5		-66				dB
V _{CT}	Crosstalk	R _L = 50 Ω, f = 1 MHz	2.7 – 5.5		-66				dB
BW	-3 dB Bandwidth	R _L = 50 Ω	2.7 – 5.5		57				MHz
THD (Note 5)	Total Harmonic Distortion	R _L = 600 Ω, V _{IS} = 0.5 V _{P-P} , f = 20 Hz to 20 kHz	2.7 – 5.5		0.004				%
C _I	Select Input Capacitance	f = 1 MHz	0		3.0				pF
C _{OFF}	NC/NO Port Off Capacitance	f = 1 MHz	4.5		23				pF
C _{ON}	COM Port ON Capacitance	f = 1 MHz	4.5		93				pF

1. Measured by the voltage drop between NC/NO and COM pins at the indicated current through the switch. On Resistance is determined by the lower of the voltages on the two (NO, NC, COM).
2. Parameter is characterized but not tested in production.
3. ΔR_{ON} = R_{ON} max – R_{ON} min measured at identical V_{CC}, temperature and voltage levels.
4. Flatness is defined as the difference between the maximum and minimum value of On Resistance over the specified range of conditions.
5. Guaranteed by Design.
6. V_{ISO} = 20 log₁₀ [V_{COM}/V_{NO,NC}].

NL5S4157A

SWITCHING CHARACTERISTICS

Symbol	Parameter	Condition	V _{CC} (V)	Guaranteed Limit					Unit
				25°C			-40°C to 125°C		
				Min	Typ	Max	Min	Max	
t _{PD} (Note 7)	Propagation Delay	V _{IN} = V _{IH} or V _{IL}	2.7			2.0		2.0	ns
			4.5			0.3		0.3	
t _{ON}	Turn-on Time, (COM to NO or NC)	R _L = 50 Ω, C _L = 35 pF, V _{IS} = 1.5 V							ns
			2.7			30		35	
			4.5			20		25	
			3.3			100		100	
t _{OFF}	Turn-off Time, (COM to NO or NC)	R _L = 50 Ω, C _L = 35 pF, V _{IS} = 1.5 V							ns
			2.7			20		25	
			4.5			15		20	
			3.3			100		100	
T _{BBM} (Note 5)	Break Before Make Time	R _L = 50 Ω, C _L = 35 pF	2.7	0.5			0.5		ns
			4.5	0.5			0.5		

7. This parameter is guaranteed by design but not tested. The bus switch contributes no propagation delay other than the RC delay of the On Resistance of the switch and the 50 pF load capacitance, when driven by an ideal voltage source (zero output impedance).

ORDERING INFORMATION

Device	Package	Marking	Pin 1 Orientation (See below)	Shipping [†]
NL5S4157ADFT2G	SC-88/SC70-6/SOT-363	AT	Q4	3000 / Tape & Reel

[†]For information on tape and reel specifications, including part orientation and tape sizes, please refer to our Tape and Reel Packaging Specifications Brochure, BRD8011/D.

PIN 1 ORIENTATION IN TAPE AND REEL

Pin 1 Orientation in Tape and Reel
Direction of Feed

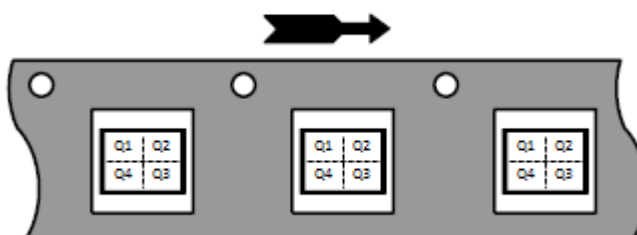

Figure 3.

Test Setups

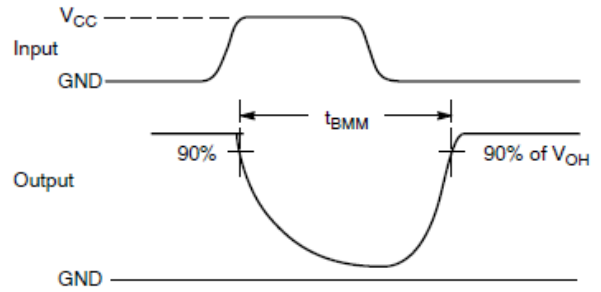
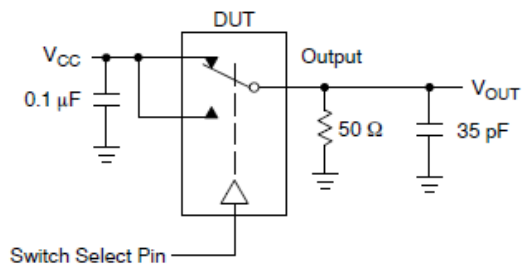

Figure 4. t_{BMM} (Time Break-Before-Make)

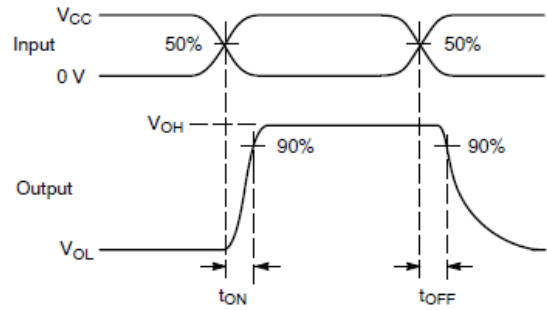
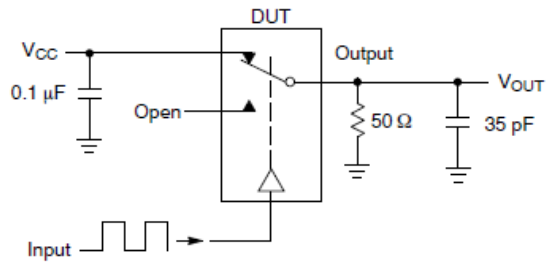

Figure 5. t_{ON}/t_{OFF}

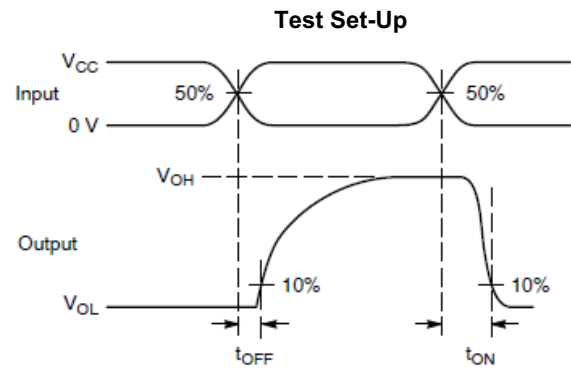
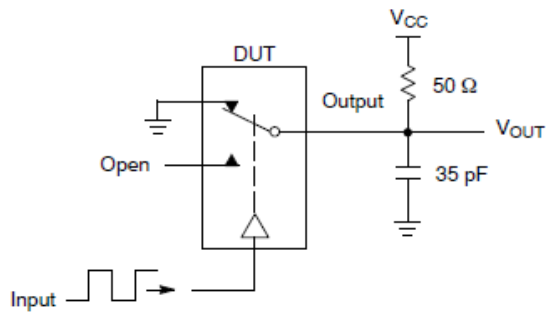
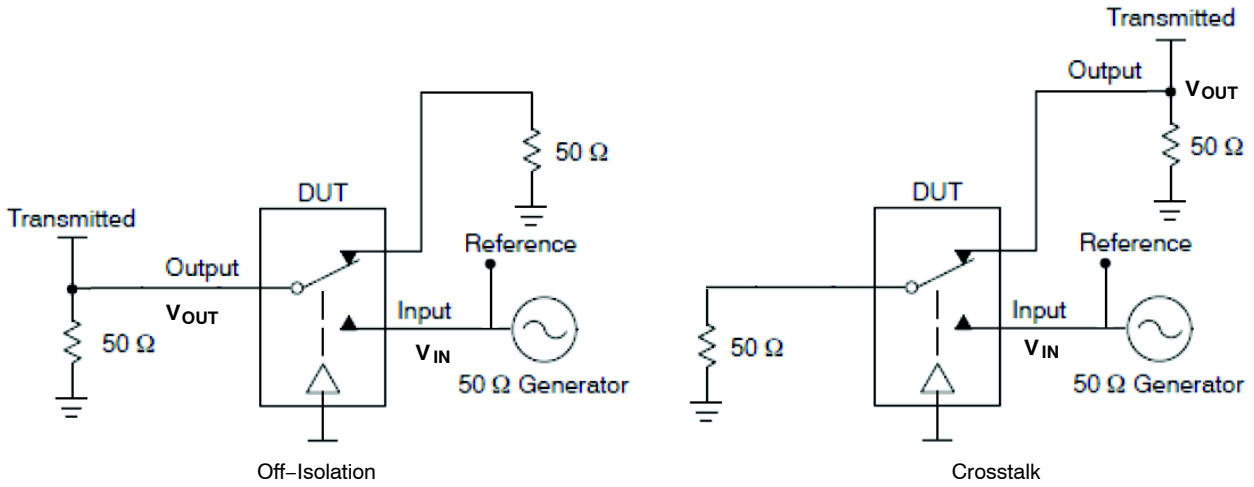

Figure 6. t_{ON}/t_{OFF}



Channel switch control/s test socket is normalized. Off isolation is measured across an off channel. Crosstalk is measured from an off channel to an on channel. On loss is the bandwidth of an On switch. V_{ISO} , V_{CT} , Bandwidth and V_{ONL} are independent of the input signal direction.

$$V_{ISO} \text{ or } V_{CT} = \text{Off Channel Isolation or crosstalk} = 20 \text{ Log for } V_{OUT} / V_{IN}$$

$$V_{ONL} = \text{On Channel Loss} = 20 \text{ Log for } V_{OUT} / V_{IN} \text{ at } 100 \text{ kHz to } 50 \text{ MHz}$$

Bandwidth (BW) = the frequency 3 dB below V_{ONL}

Figure 7. Off Channel Isolation/On Channel Loss (BW)/Crosstalk (On Channel to Off Channel)/ V_{ONL}

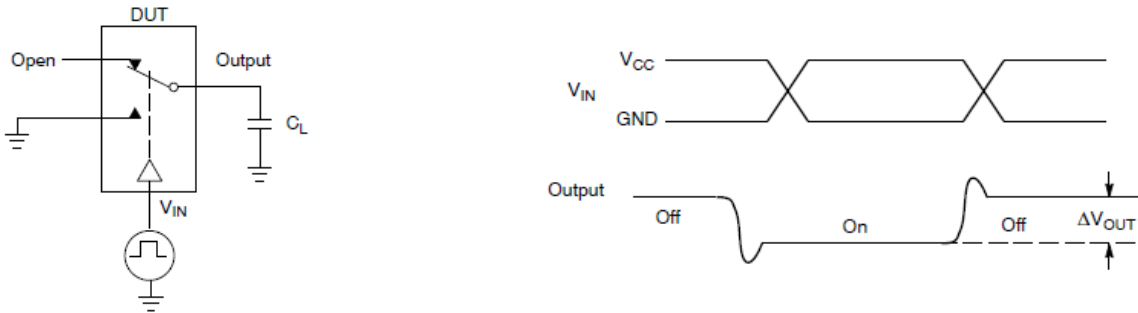

Figure 8. Charge Injection: (Q)

TYPICAL CHARACTERISTICS

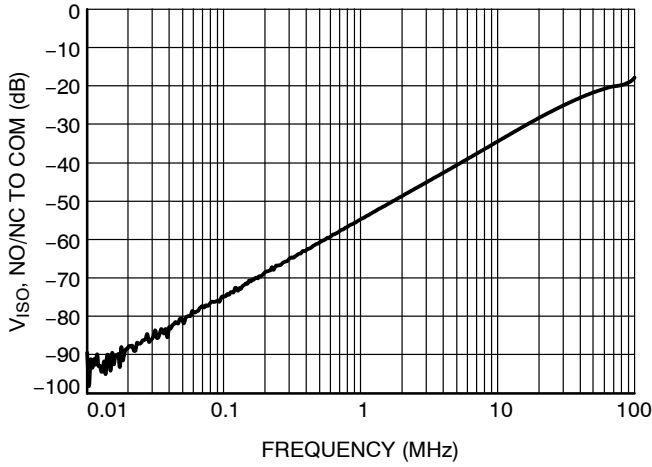

Figure 9. V_{ISO} vs. Frequency
@ $V_{CC} = 4.5\text{ V}$

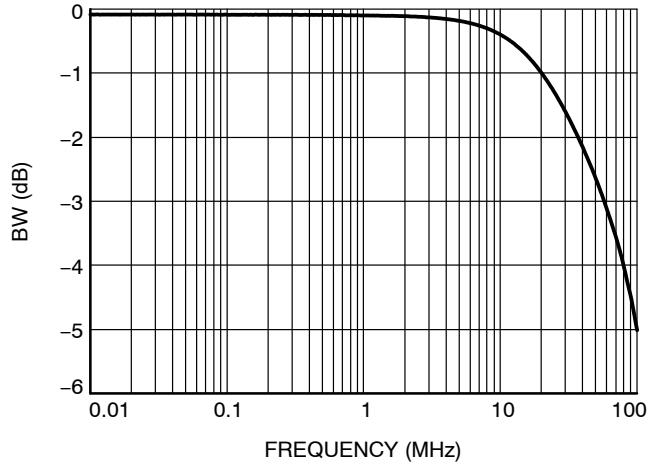

Figure 10. Bandwidth vs. Frequency

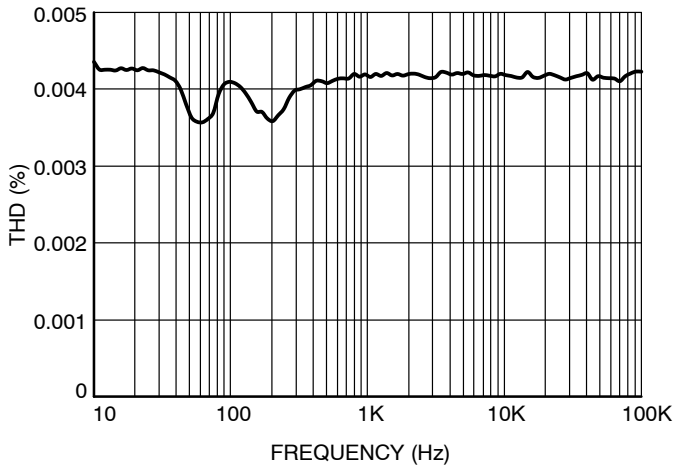

Figure 11. Total Harmonic Distortion

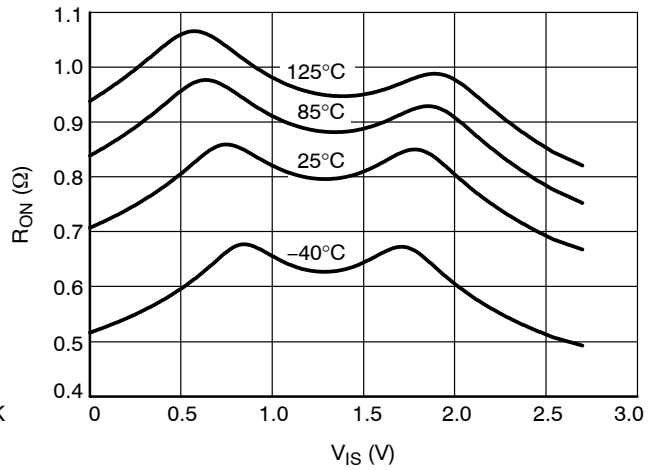

Figure 12. ON Resistance vs. Switch Voltage
@ $V_{CC} = 2.7\text{ V}$

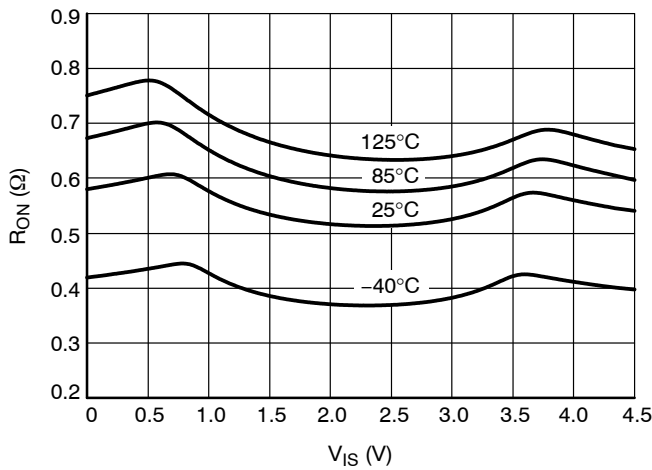

Figure 13. ON Resistance vs. Switch Voltage
@ $V_{CC} = 4.5\text{ V}$

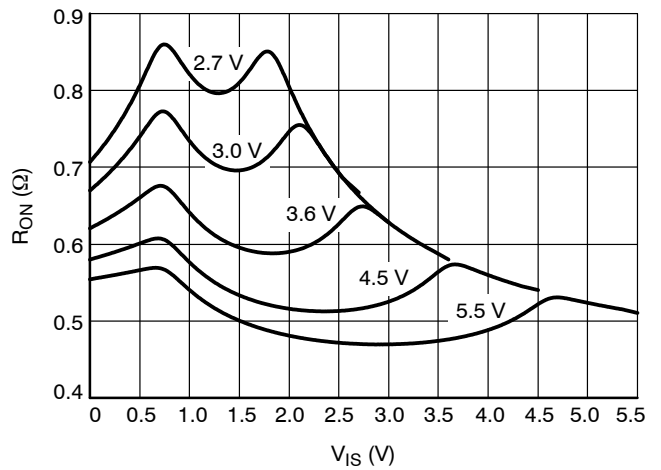

Figure 14. ON Resistance vs. Switch Voltage



1
 SCALE 2:1

SC-88/SC70-6/SOT-363
 CASE 419B-02
 ISSUE Y

DATE 11 DEC 2012

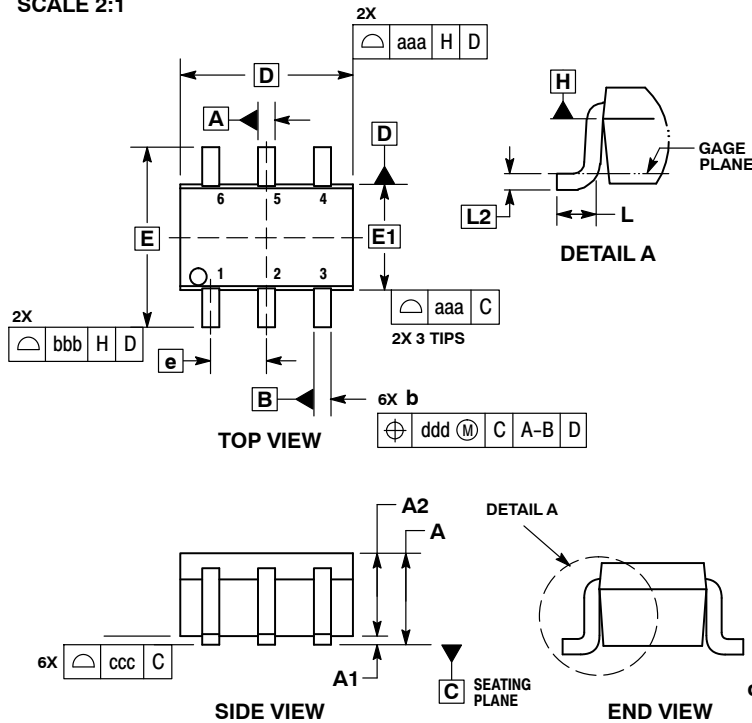

- NOTES:
1. DIMENSIONING AND TOLERANCING PER ASME Y14.5M, 1994.
 2. CONTROLLING DIMENSION: MILLIMETERS.
 3. DIMENSIONS D AND E1 DO NOT INCLUDE MOLD FLASH, PROTRUSIONS, OR GATE BURRS. MOLD FLASH, PROTRUSIONS, OR GATE BURRS SHALL NOT EXCEED 0.20 PER END.
 4. DIMENSIONS D AND E1 AT THE OUTERMOST EXTREMES OF THE PLASTIC BODY AND DATUM H.
 5. DATUMS A AND B ARE DETERMINED AT DATUM H.
 6. DIMENSIONS b AND c APPLY TO THE FLAT SECTION OF THE LEAD BETWEEN 0.08 AND 0.15 FROM THE TIP.
 7. DIMENSION b DOES NOT INCLUDE DAMBAR PROTRUSION. ALLOWABLE DAMBAR PROTRUSION SHALL BE 0.08 TOTAL IN EXCESS OF DIMENSION b AT MAXIMUM MATERIAL CONDITION. THE DAMBAR CANNOT BE LOCATED ON THE LOWER RADIUS OF THE FOOT.

DIM	MILLIMETERS			INCHES		
	MIN	NOM	MAX	MIN	NOM	MAX
A	---	---	1.10	---	---	0.043
A1	0.00	---	0.10	0.000	---	0.004
A2	0.70	0.90	1.00	0.027	0.035	0.039
b	0.15	0.20	0.25	0.006	0.008	0.010
C	0.08	0.15	0.22	0.003	0.006	0.009
D	1.80	2.00	2.20	0.070	0.078	0.086
E	2.00	2.10	2.20	0.078	0.082	0.086
E1	1.15	1.25	1.35	0.045	0.049	0.053
e	0.65 BSC			0.026 BSC		
L	0.26	0.36	0.46	0.010	0.014	0.018
L2	0.15 BSC			0.006 BSC		
aaa	0.15			0.006		
bbb	0.30			0.012		
ccc	0.10			0.004		
ddd	0.10			0.004		

GENERIC MARKING DIAGRAM*

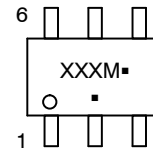

- XXX = Specific Device Code
- M = Date Code*
- = Pb-Free Package

(Note: Microdot may be in either location)

*Date Code orientation and/or position may vary depending upon manufacturing location.

*This information is generic. Please refer to device data sheet for actual part marking. Pb-Free indicator, "G" or microdot "▪", may or may not be present.

RECOMMENDED SOLDERING FOOTPRINT*

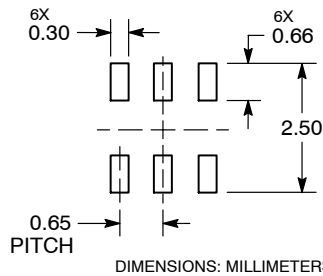

*For additional information on our Pb-Free strategy and soldering details, please download the ON Semiconductor Soldering and Mounting Techniques Reference Manual, SOLDERRM/D.

STYLES ON PAGE 2

DOCUMENT NUMBER:	98ASB42985B	Electronic versions are uncontrolled except when accessed directly from the Document Repository. Printed versions are uncontrolled except when stamped "CONTROLLED COPY" in red.
DESCRIPTION:	SC-88/SC70-6/SOT-363	PAGE 1 OF 2

ON Semiconductor and ON are trademarks of Semiconductor Components Industries, LLC dba ON Semiconductor or its subsidiaries in the United States and/or other countries. ON Semiconductor reserves the right to make changes without further notice to any products herein. ON Semiconductor makes no warranty, representation or guarantee regarding the suitability of its products for any particular purpose, nor does ON Semiconductor assume any liability arising out of the application or use of any product or circuit, and specifically disclaims any and all liability, including without limitation special, consequential or incidental damages. ON Semiconductor does not convey any license under its patent rights nor the rights of others.

SC-88/SC70-6/SOT-363
CASE 419B-02
ISSUE Y

DATE 11 DEC 2012

STYLE 1: PIN 1. EMITTER 2 2. BASE 2 3. COLLECTOR 1 4. EMITTER 1 5. BASE 1 6. COLLECTOR 2	STYLE 2: CANCELLED	STYLE 3: CANCELLED	STYLE 4: PIN 1. CATHODE 2. CATHODE 3. COLLECTOR 4. EMITTER 5. BASE 6. ANODE	STYLE 5: PIN 1. ANODE 2. ANODE 3. COLLECTOR 4. EMITTER 5. BASE 6. CATHODE	STYLE 6: PIN 1. ANODE 2 2. N/C 3. CATHODE 1 4. ANODE 1 5. N/C 6. CATHODE 2
STYLE 7: PIN 1. SOURCE 2 2. DRAIN 2 3. GATE 1 4. SOURCE 1 5. DRAIN 1 6. GATE 2	STYLE 8: CANCELLED	STYLE 9: PIN 1. EMITTER 2 2. EMITTER 1 3. COLLECTOR 1 4. BASE 1 5. BASE 2 6. COLLECTOR 2	STYLE 10: PIN 1. SOURCE 2 2. SOURCE 1 3. GATE 1 4. DRAIN 1 5. DRAIN 2 6. GATE 2	STYLE 11: PIN 1. CATHODE 2 2. CATHODE 2 3. ANODE 1 4. CATHODE 1 5. CATHODE 1 6. ANODE 2	STYLE 12: PIN 1. ANODE 2 2. ANODE 2 3. CATHODE 1 4. ANODE 1 5. ANODE 1 6. CATHODE 2
STYLE 13: PIN 1. ANODE 2. N/C 3. COLLECTOR 4. EMITTER 5. BASE 6. CATHODE	STYLE 14: PIN 1. VREF 2. GND 3. GND 4. IOUT 5. VEN 6. VCC	STYLE 15: PIN 1. ANODE 1 2. ANODE 2 3. ANODE 3 4. CATHODE 3 5. CATHODE 2 6. CATHODE 1	STYLE 16: PIN 1. BASE 1 2. EMITTER 2 3. COLLECTOR 2 4. BASE 2 5. EMITTER 1 6. COLLECTOR 1	STYLE 17: PIN 1. BASE 1 2. EMITTER 1 3. COLLECTOR 2 4. BASE 2 5. EMITTER 2 6. COLLECTOR 1	STYLE 18: PIN 1. VIN1 2. VCC 3. VOUT2 4. VIN2 5. GND 6. VOUT1
STYLE 19: PIN 1. IOUT 2. GND 3. GND 4. V CC 5. V EN 6. V REF	STYLE 20: PIN 1. COLLECTOR 2. COLLECTOR 3. BASE 4. EMITTER 5. COLLECTOR 6. COLLECTOR	STYLE 21: PIN 1. ANODE 1 2. N/C 3. ANODE 2 4. CATHODE 2 5. N/C 6. CATHODE 1	STYLE 22: PIN 1. D1 (i) 2. GND 3. D2 (i) 4. D2 (c) 5. VBUS 6. D1 (c)	STYLE 23: PIN 1. Vn 2. CH1 3. Vp 4. N/C 5. CH2 6. N/C	STYLE 24: PIN 1. CATHODE 2. ANODE 3. CATHODE 4. CATHODE 5. CATHODE 6. CATHODE
STYLE 25: PIN 1. BASE 1 2. CATHODE 3. COLLECTOR 2 4. BASE 2 5. EMITTER 6. COLLECTOR 1	STYLE 26: PIN 1. SOURCE 1 2. GATE 1 3. DRAIN 2 4. SOURCE 2 5. GATE 2 6. DRAIN 1	STYLE 27: PIN 1. BASE 2 2. BASE 1 3. COLLECTOR 1 4. EMITTER 1 5. EMITTER 2 6. COLLECTOR 2	STYLE 28: PIN 1. DRAIN 2. DRAIN 3. GATE 4. SOURCE 5. DRAIN 6. DRAIN	STYLE 29: PIN 1. ANODE 2. ANODE 3. COLLECTOR 4. EMITTER 5. BASE/ANODE 6. CATHODE	STYLE 30: PIN 1. SOURCE 1 2. DRAIN 2 3. DRAIN 2 4. SOURCE 2 5. GATE 1 6. DRAIN 1

DOCUMENT NUMBER:	98ASB42985B	Electronic versions are uncontrolled except when accessed directly from the Document Repository. Printed versions are uncontrolled except when stamped "CONTROLLED COPY" in red.
DESCRIPTION:	SC-88/SC70-6/SOT-363	PAGE 2 OF 2

ON Semiconductor and  are trademarks of Semiconductor Components Industries, LLC dba ON Semiconductor or its subsidiaries in the United States and/or other countries. ON Semiconductor reserves the right to make changes without further notice to any products herein. ON Semiconductor makes no warranty, representation or guarantee regarding the suitability of its products for any particular purpose, nor does ON Semiconductor assume any liability arising out of the application or use of any product or circuit, and specifically disclaims any and all liability, including without limitation special, consequential or incidental damages. ON Semiconductor does not convey any license under its patent rights nor the rights of others.

ON Semiconductor and  are trademarks of Semiconductor Components Industries, LLC dba ON Semiconductor or its subsidiaries in the United States and/or other countries. ON Semiconductor owns the rights to a number of patents, trademarks, copyrights, trade secrets, and other intellectual property. A listing of ON Semiconductor's product/patent coverage may be accessed at www.onsemi.com/site/pdf/Patent-Marking.pdf. ON Semiconductor reserves the right to make changes without further notice to any products herein. ON Semiconductor makes no warranty, representation or guarantee regarding the suitability of its products for any particular purpose, nor does ON Semiconductor assume any liability arising out of the application or use of any product or circuit, and specifically disclaims any and all liability, including without limitation special, consequential or incidental damages. Buyer is responsible for its products and applications using ON Semiconductor products, including compliance with all laws, regulations and safety requirements or standards, regardless of any support or applications information provided by ON Semiconductor. "Typical" parameters which may be provided in ON Semiconductor data sheets and/or specifications can and do vary in different applications and actual performance may vary over time. All operating parameters, including "Typicals" must be validated for each customer application by customer's technical experts. ON Semiconductor does not convey any license under its patent rights nor the rights of others. ON Semiconductor products are not designed, intended, or authorized for use as a critical component in life support systems or any FDA Class 3 medical devices or medical devices with a same or similar classification in a foreign jurisdiction or any devices intended for implantation in the human body. Should Buyer purchase or use ON Semiconductor products for any such unintended or unauthorized application, Buyer shall indemnify and hold ON Semiconductor and its officers, employees, subsidiaries, affiliates, and distributors harmless against all claims, costs, damages, and expenses, and reasonable attorney fees arising out of, directly or indirectly, any claim of personal injury or death associated with such unintended or unauthorized use, even if such claim alleges that ON Semiconductor was negligent regarding the design or manufacture of the part. ON Semiconductor is an Equal Opportunity/Affirmative Action Employer. This literature is subject to all applicable copyright laws and is not for resale in any manner.

PUBLICATION ORDERING INFORMATION

LITERATURE FULFILLMENT:

Email Requests to: orderlit@onsemi.com

ON Semiconductor Website: www.onsemi.com

TECHNICAL SUPPORT

North American Technical Support:
Voice Mail: 1 800-282-9855 Toll Free USA/Canada
Phone: 011 421 33 790 2910

Europe, Middle East and Africa Technical Support:

Phone: 00421 33 790 2910

For additional information, please contact your local Sales Representative