

## VOLTAGE CONVERTER

### ■ GENERAL DESCRIPTION

NJU7660A is a CMOS switched capacitor, voltage converter designed to be an Improved direct replacement of popular 7660/1044.

NJU7660A provides several voltage conversion functions.

The application circuit of negative voltage( $V_{OUT}=-V_{IN}$ ) converter requires only two capacitors, and positive twofold voltage( $V_{OUT}=2V_{IN}$ ) converter requires two capacitors and two diode as external components.

### ■ PACKAGE OUTLINE

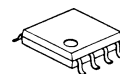

NJU7660AM



NJU7660AV

### ■ FEATURES

- Full Compatible with NJU7660
- Correspond to MLCC and electrolytic capacitor
- Twofold positive Output
- Polarity-converted Negative voltage Output
- Operating voltage range
  - :+1.5V to +10V(for Negative voltage converter)
  - :+3.0V to +10V(for Twofold voltage converter)
- High-efficiency voltage conversion rate
  - :99.9%(No load, Negative voltage converter)
- Few external components
  - :2 capacitors(Negative voltage converter)
  - :2 capacitors, 2diode(Twofold voltage converter)
- Package Outline
  - :DMP8, SSOP8
- CMOS Technology

### ■ PIN CONFIGURATION

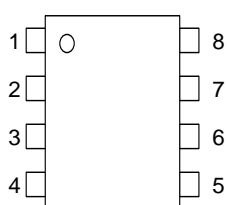

NJU7660AM  
NJU7660AV

#### PIN FUNCTION

1. N.C. :Non Connection
2. C<sup>+</sup> :Charge pump Capacitor(+) Connecting pin
3. GND :Ground pin
4. C<sup>-</sup> :Charge pump Capacitor(-) Connecting pin
5. V<sub>OUT</sub> :Voltage Output pin
6. V<sub>R</sub> :Voltage Regulator Control pin
7. OSC :Oscillation Capacitor Connecting pin
8. V<sup>+</sup> :Power Supply pin

### ■ PRODUCT CLASSIFICATION

Device Name	Oscillation Frequency	Output Resistance	Operating Current	C1/C2 capacitor	Status
NJU7660A	5kHz typ.	55Ω typ.	40μA typ.	10μF	M.P
NJU7660B	200kHz typ.	30Ω typ.	800μA typ.	1μF	PLAN

# NJU7660A

## ■ BLOCK DIAGRAM

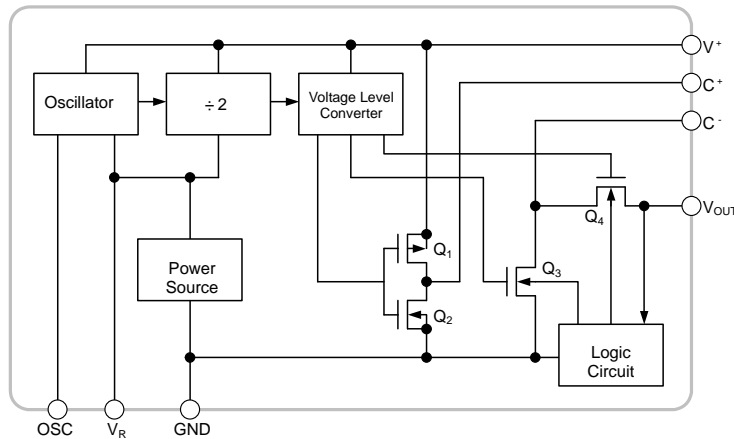

## ■ ABSOLUTE MAXIMUM RATINGS

(Ta=25°C)

PARAMETER	SYMBOL	RATINGS	UNIT	
Supply Voltage	V <sup>+</sup>	10.5	V	
OSC Pin Voltage	V <sub>OSC</sub>	-0.3 ~ (V <sup>+</sup> +0.3) @ V <sup>+</sup> < 5.5 (V <sup>+</sup> -5.5) ~ (V <sup>+</sup> +0.3) @ V <sup>+</sup> > 5.5	V	
V <sub>R</sub> Pin Voltage	V <sub>VR</sub>	-0.3 ~ (V <sup>+</sup> +0.3) @ V <sup>+</sup> < 5.5 (V <sup>+</sup> -5.5) ~ (V <sup>+</sup> +0.3) @ V <sup>+</sup> > 5.5	V	
V <sub>R</sub> Pin Current (*3)	I <sub>VR</sub>	20	μA	
Output Short		CONTINUITY @ V <sup>+</sup> < 5.5		
Power Dissipation	P <sub>D</sub>	DMP8	470(*1) 600(*2)	mW
		SSOP8	410(*1) 510(*2)	
Junction Temperature Range	T <sub>J</sub>	- 40 ~ +150	°C	
Operating Temperature Range	T <sub>opr</sub>	- 40 ~ + 85	°C	
Storage Temperature Range	T <sub>stg</sub>	- 40 ~ +150	°C	

(\*1): Mounted on glass epoxy board. (76.2 × 114.3 × 1.6mm:based on EIA/JDEC standard, 2Layers)

(\*2): Mounted on glass epoxy board. (76.2 × 114.3 × 1.6mm:based on EIA/JDEC standard, 4Layers,internal Cu area: 74.2 × 74.2mm)

(\*3): Connecting any input terminal to voltages greater than V<sup>+</sup> or less than GND may cause destructive latchup. It is recommended that no inputs from sources operating from external supplies be applied prior to "power-up" of the NJU7660A

## ■ INPUT VOLTAGE RANGE

V<sup>+</sup>=1.5V to 10V (for Negative Voltage Converter)

V<sup>+</sup>=3.0V to 10V (for Twofold Voltage Converter)

## ■ ELECTRICAL CHARACTERISTICS

(Unless otherwise noted,  $V^+=5.0V$ ,  $C_{OSC}=0$ ,  $T_a=25^\circ C$ )

PARAMETER	SYMBOL	TEST CONDITION	MIN.	TYP.	MAX.	UNIT	
Operating Current	$I^+$	$R_L=\infty$	-	40	130	$\mu A$	
Operating Voltage 1 (Without Dx)	$V_{H1}^+$	$R_L=10k\Omega$	$V_R=OPEN$	3.0	-	6.5	V
	$V_{L1}^+$		$V_R=GND$	1.5	-	3.5	V
Operating Voltage 2 (With Dx)	$V_{H2}^+$	$R_L=10k\Omega$	$V_R=OPEN$	3.0	-	10	V
	$V_{L2}^+$		$V_R=GND$	1.5	-	3.5	V
Output Resistance	$R_o$	$I_{OUT}=20mA$	-	55	100	$\Omega$	
		$V^+=2V, I_{OUT}=3mA, V_R=GND$	-	-	300	$\Omega$	
Oscillation Frequency	$F_o$		-	5	-	kHz	
Power Conversion Rate	$P_{EF}$	$R_L=5k\Omega$	90	98	-	%	
Voltage Conversion Rate	$V_{EF}$	$R_L=\infty$	97	99.9	-	%	
Oscillation Circuit Impedance	$Z_{OSC}$	$V^+=2V$	-	1.0	-	M $\Omega$	
		$V^+=5V$	-	0.1	-		

(\*4): The twofold voltage converter operates over 3.0V

## ■ POWER DISSIPATION vs. AMBIENT TEMPERATURE

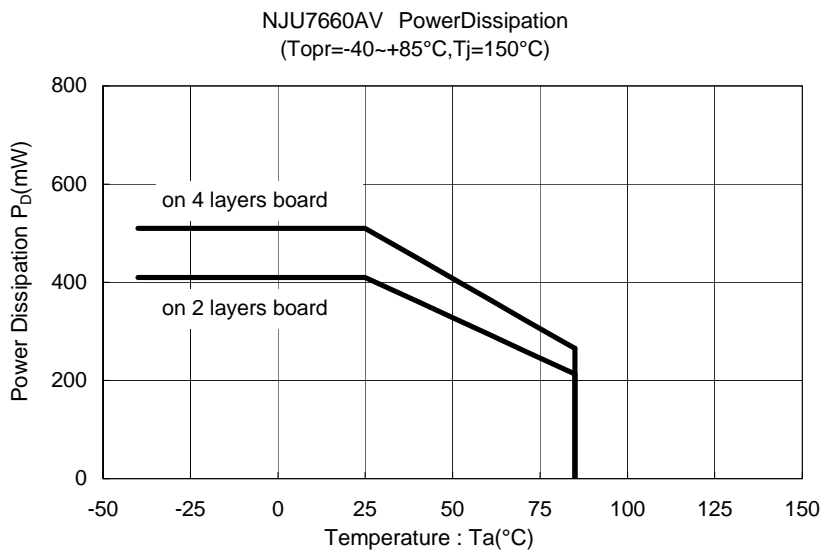
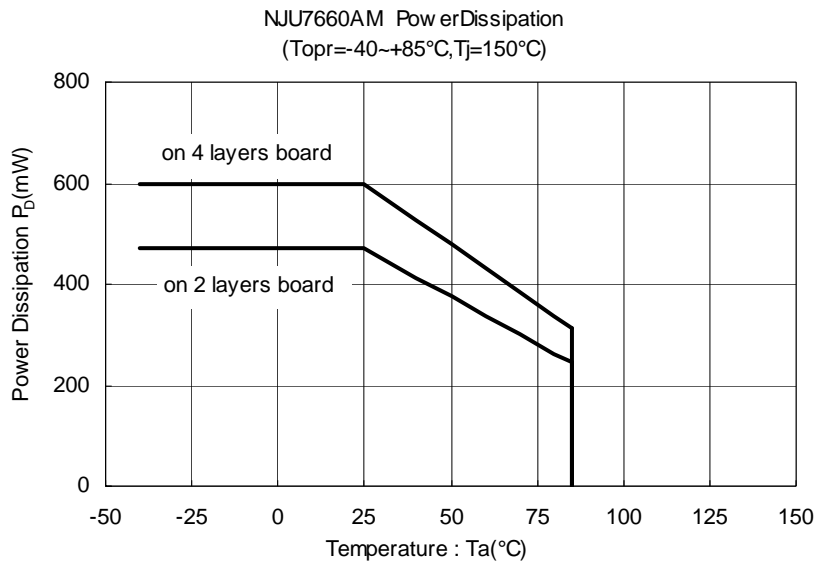

## ■ TEST CIRCUIT

The measurement circuit diagram of negative voltage is shown below.  $V_R$  pin must connect to GND or Open according to the operating voltage as follows:

$V^+ < 3.5V$  :Connected to GND

$V^+ \geq 3.5V$  :OPEN

The oscillation frequency can be lowered by connected external capacitor to the OSC pin, furthermore it can be also driven by external clock generator.

## ■ TYPICAL APPLICATION

### ( 1-1 ) Negative Voltage Output 1 1.5V to 3.5V operation

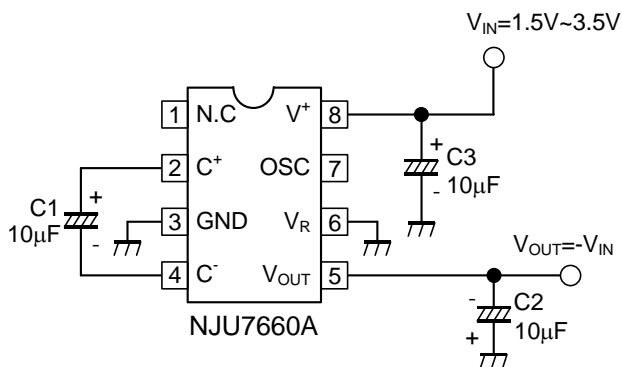

\*Its Can also be used ceramic capacitor. (C1,C2,C3)  
\*Capacitance of C3 is equal to C1,C2 or more.

### ( 1-2 ) Negative Voltage Output 2 3.5V to 10V operation

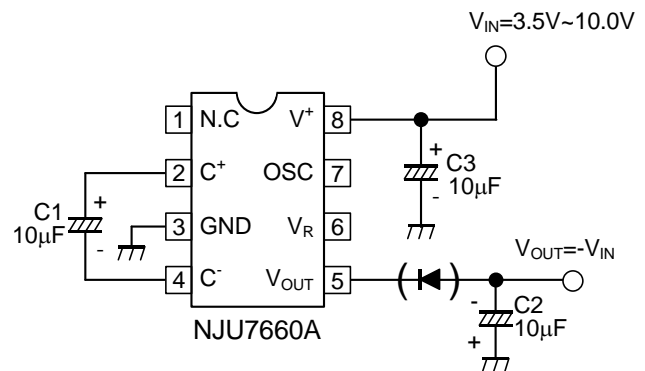

\*Can also be used ceramic capacitor. (C1,C2,C3)  
\*Capacitance of C3 is equal to C1,C2 or more.

(\*6):  $V_R$  pin must connect to GND or Open according to the operating voltage as follows:

$V^+ < 3.5V$  :Connected to GND

$V^+ \geq 3.5V$  :OPEN

(\*7): In case of the operation voltage is 6.5V or more, a Diode must be connected to  $V_{OUT}$  pin. If it is less than 6.5V, the Diode is not required

### ( 2 ) Twofold positive Voltage Output

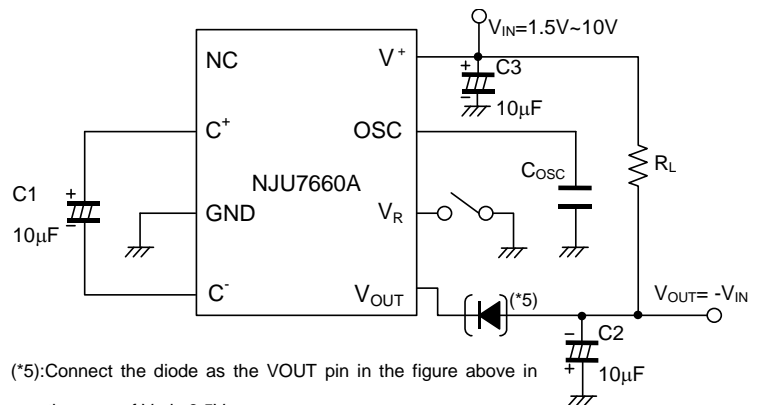

(\*5): Connect the diode as the  $V_{OUT}$  pin in the figure above in the case of  $V^+$  is 6.5V or more.

In the case of less than 6.5V,  $V^+$  does not require this diode.

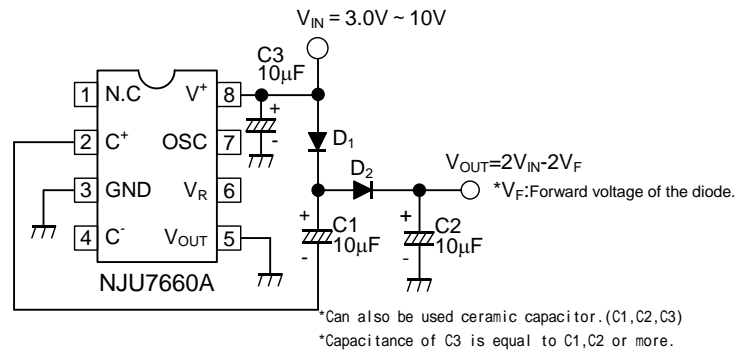

### (3) Cascade Connection (Negative Voltage Output)

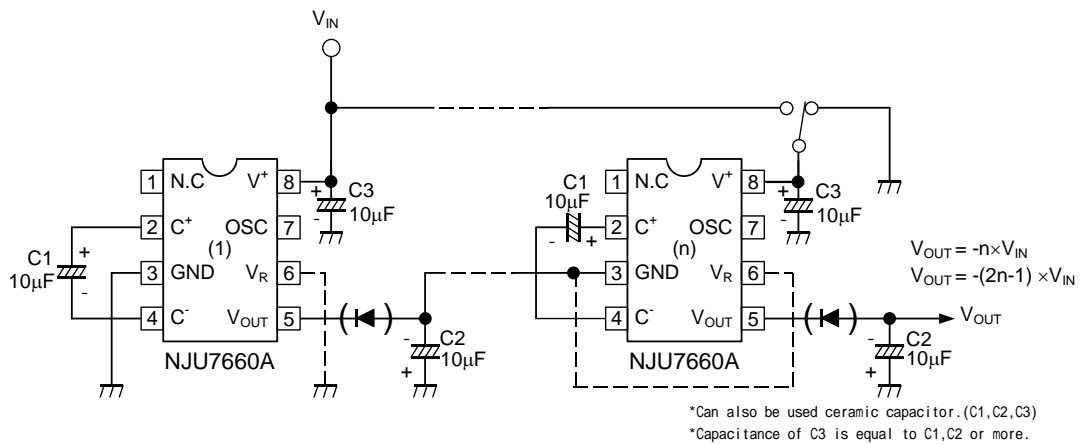

(\*8):  $V_R$  pin must connect to GND or Open according to the operating voltage as follows:

$V^+ < 3.5V$  : Connected to GND

$V^+ \geq 3.5V$  : OPEN

(\*9): In case of the operation voltage is 6.5V or more, a Diode must be connected to  $V_{OUT}$  pin. If it is less than 6.5V, the Diode is not required

(\*10): In case of the cascade connection (Negative Voltage Output),  $V_R$  pins (after second IC's) must connect as follows, according to  $V^+ - GND$  Voltage.

$V^+ - GND < 3.5V$  : Connected to GND

$V^+ - GND \geq 3.5V$  : OPEN

(\*11): Output resistance becomes total of the  $R_o$  of every NJU7660A

■ TYPICAL CHARACTERISTICS (Common)

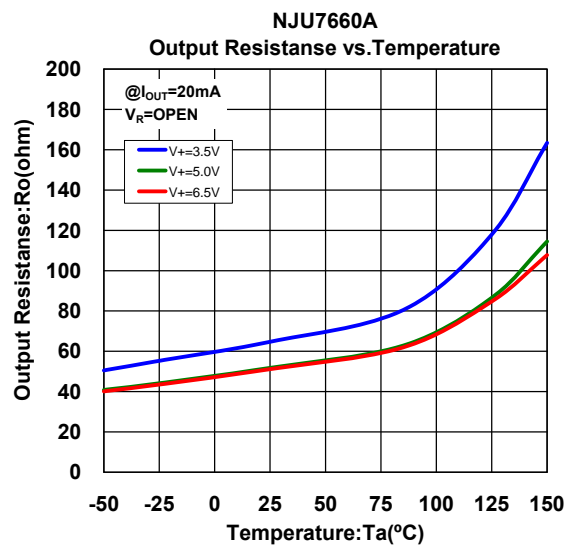
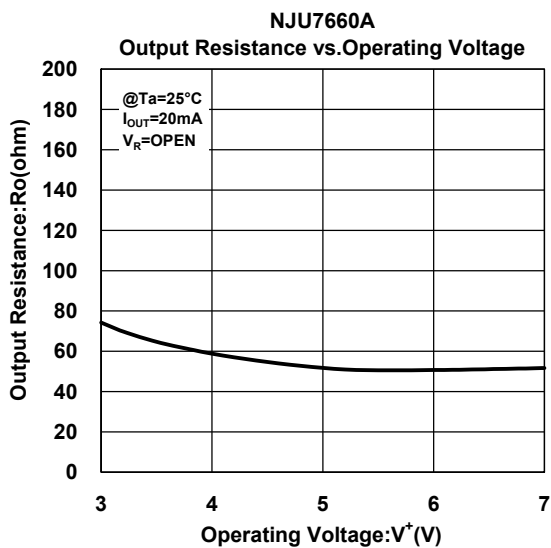
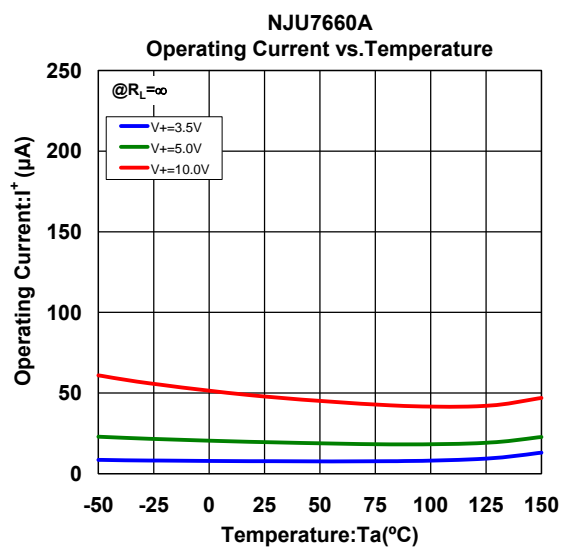
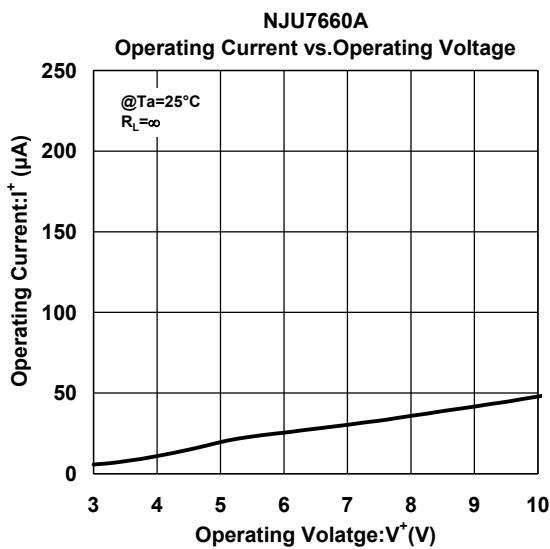

# NJU7660A

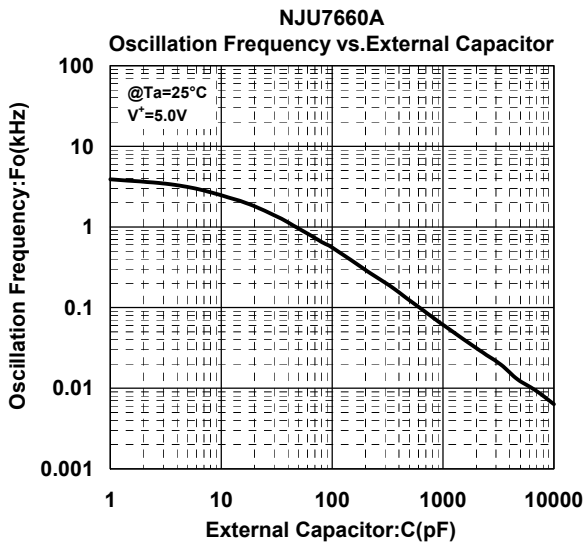

■ TYPICAL CHARACTERISTICS (Negative Circuit)

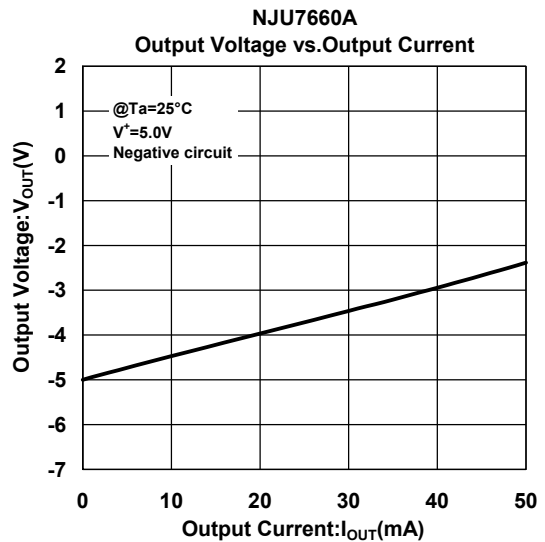
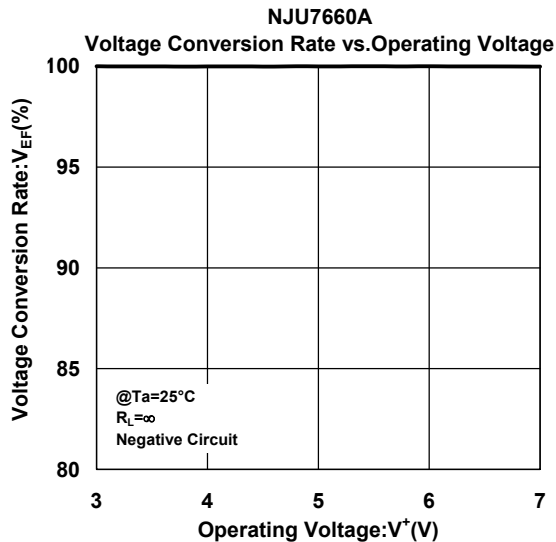
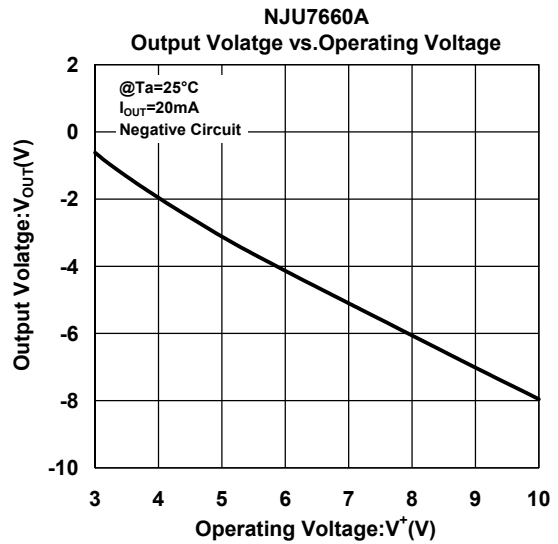
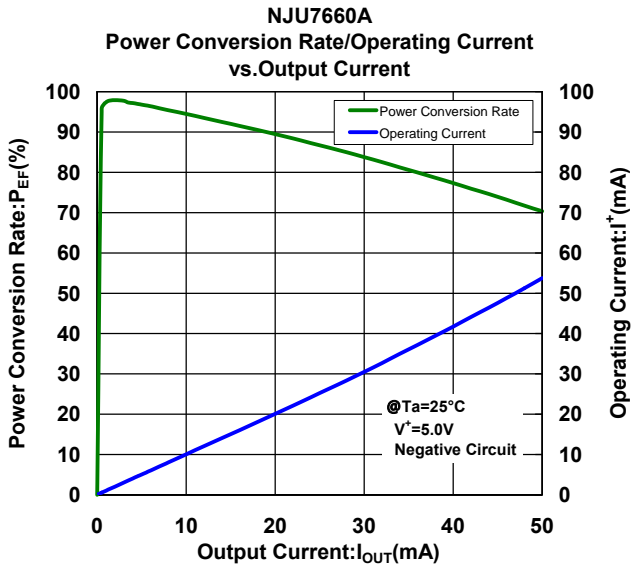

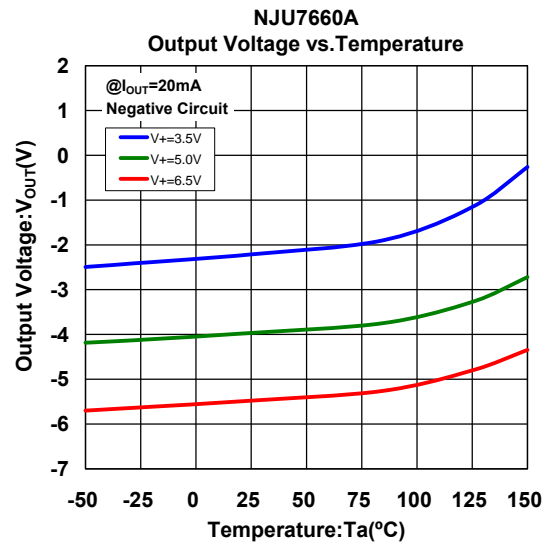
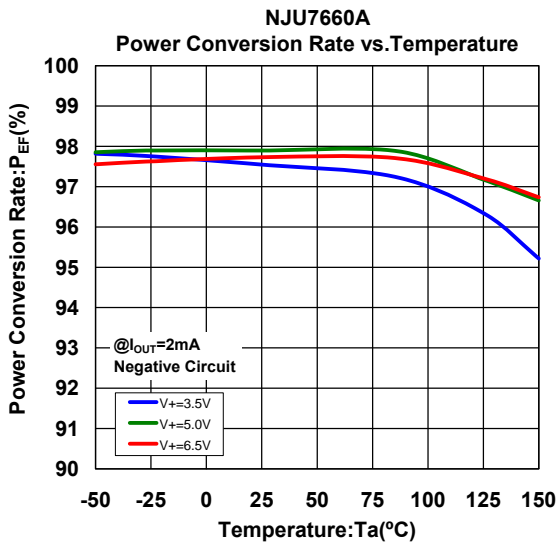

■ TYPICAL CHARACTERISTICS (Twofold Circuit)

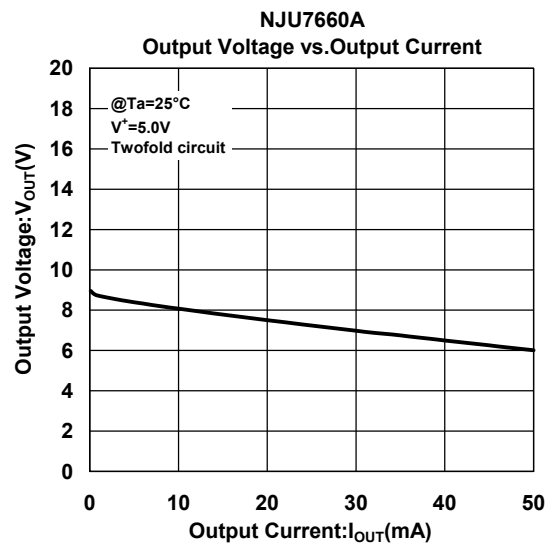
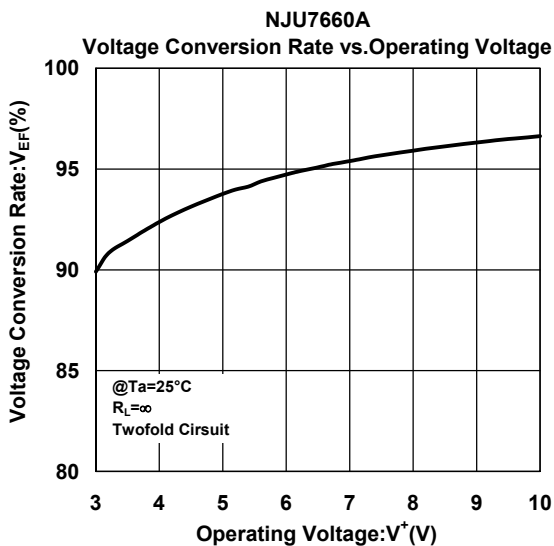
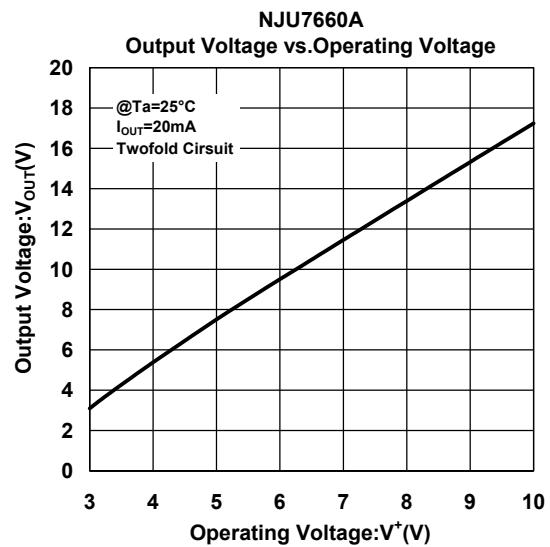
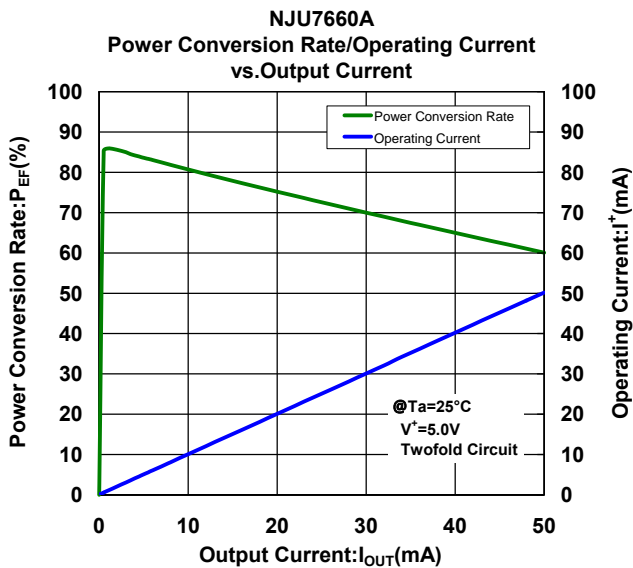

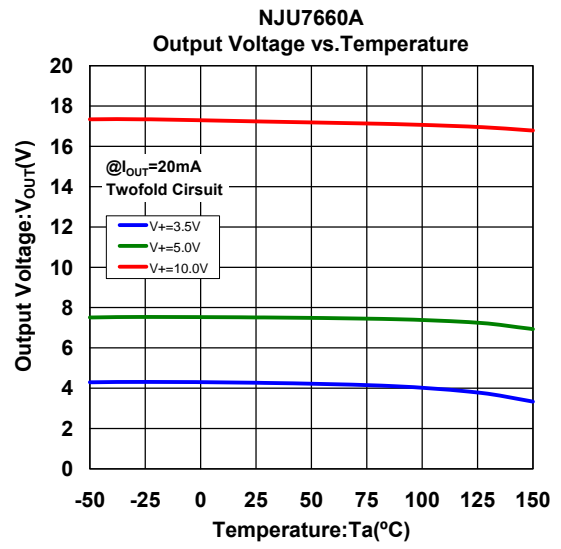
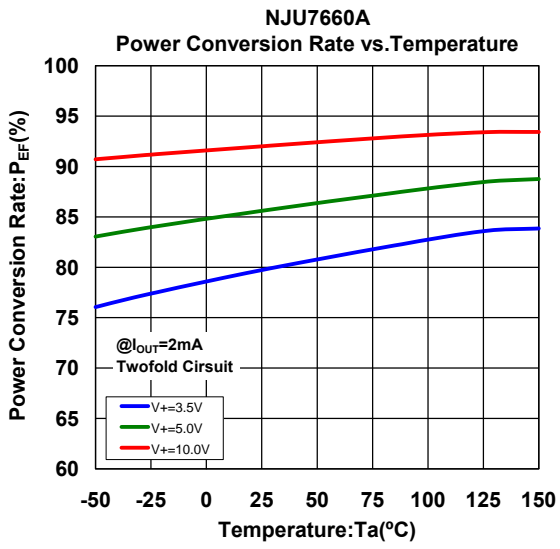

**[CAUTION]**

The specifications on this databook are only given for information, without any guarantee as regards either mistakes or omissions. The application circuits in this databook are described only to show representative usages of the product and not intended for the guarantee or permission of any right including the industrial rights.