

# NHD-4.3-800480CF-ASXP

## TFT (Thin-Film-Transistor) Color Liquid Crystal Display Module

NHD-	Newhaven Display
4.3-	4.3" Diagonal
800480-	800xRGBx480 Pixels
CF-	Model
A-	Built-in Driver / No Controller
S-	High Brightness, White LED Backlight
X-	TFT
P-	IPS, Wide Temperature

**Newhaven Display International, Inc.**

2661 Galvin Ct.

Elgin IL, 60124

Ph: 847-844-8795

Fax: 847-844-8796

[www.newhavendisplay.com](http://www.newhavendisplay.com)

[nhtech@newhavendisplay.com](mailto:nhtech@newhavendisplay.com)

[nhsales@newhavendisplay.com](mailto:nhsales@newhavendisplay.com)

## Document Revision History

Revision	Date	Description	Changed by
-	10/20/19	Initial Release	PK

## Functions and Features

- 800xRGBx480 resolution, up to 16.7M colors
- High-brightness LED backlight
- IPS Type, Full Viewing Angles
- 24-Bit RGB interface
- Capacitive touch panel available

SYMBOL	REVISION	DATE

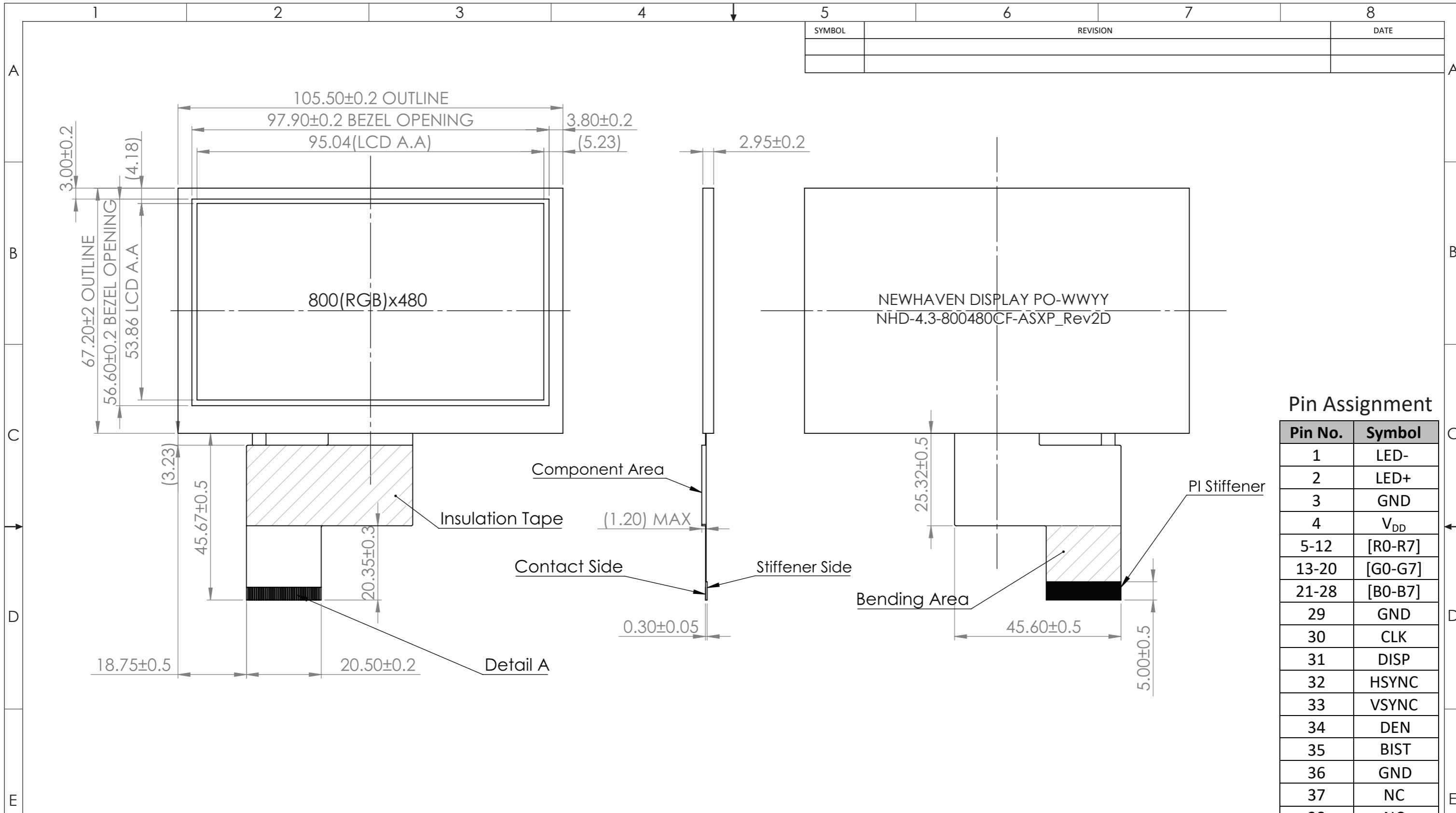

- Notes:
- Display Size: 4.3" TFT
  - Optimal View: Full View IPS
  - Display Mode: Transmissive / Normally Black / Anti-Glare
  - Driver IC: EK9716BE3+EK73002AB2
  - Supply Voltage: 3.3V
  - Backlight: White LED / 25.6V / 40mA (Typ)
  - Luminance: 850 cd/m<sup>2</sup> (Typ)
  - 3M Brightness Enhancement Film

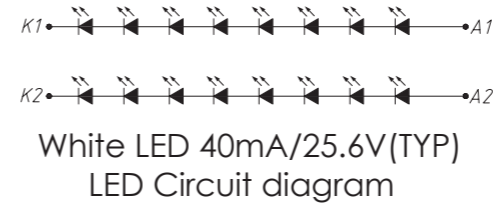
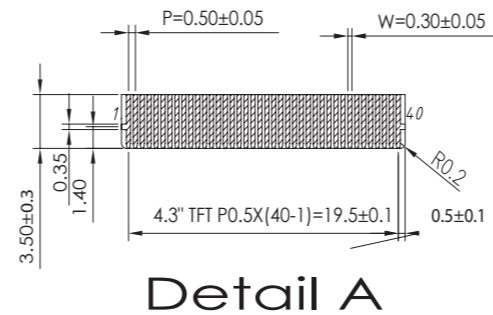

STANDARD TOLERANCE: (UNLESS OTHERWISE SPECIFIED)  
LINEAR: ±0.3mm

UNLESS OTHERWISE SPECIFIED:  
- DIMENSIONS ARE IN MILLIMETERS  
- THIRD ANGLE PROJECTION

**NEWHAVEN DISPLAY INTERNATIONAL**

DRAWING/PART NUMBER: NHD-4.3-800480CF-ASXP

REVISION: -

SIZE: A3

SCALE: 1:1

DO NOT SCALE DRAWING SHEET 1 OF 1

THIS DRAWING IS SOLELY THE PROPERTY OF NEWHAVEN DISPLAY INTERNATIONAL, INC. THE INFORMATION IT CONTAINS IS NOT TO BE DISCLOSED, REPRODUCED OR COPIED IN WHOLE OR PART WITHOUT WRITTEN APPROVAL FROM NEWHAVEN DISPLAY.

## Pin Description

Pin No.	Symbol	External Connection	Function Description
1	LED-	Power Supply	Backlight Cathode (Ground)
2	LED+	Power Supply	Backlight Anode (25.6V @ 40 mA)
3	GND	Power Supply	Ground
4	VDD	Power Supply	Supply Voltage for LCD and logic (3.3V)
5-12	[R0-R7]	MPU	Red Data signals
13-20	[G0-G7]	MPU	Green Data signals
21-28	[B0-B7]	MPU	Blue Data signals
29	GND	Power Supply	Ground
30	CLK	MPU	Pixel Clock signal
31	DISP	MPU	Display ON/OFF Signal
32	HSYNC	MPU	Line synchronization signal
33	VSYNC	MPU	Frame synchronization signal
34	DEN	MPU	Data Enable signal
35	BIST	MPU	Built in Self-Test. BIST = H: Self-Test Enabled. BIST = L: Normal Operation (Default)
36	GND	Power Supply	Ground
37	NC	-	No Connect
38	NC	-	No Connect
39	NC	-	No Connect
40	NC	-	No Connect

**Recommended LCD connector:** 0.5mm pitch 40-Conductor FFC. **Molex p/n:** 54104-4031 (top contact)

## Electrical Characteristics

Item	Symbol	Condition	Min.	Typ.	Max.	Unit
Operating Temperature Range	T <sub>OP</sub>	Absolute Max	-20	-	+70	°C
Storage Temperature Range	T <sub>ST</sub>	Absolute Max	-30	-	+80	°C
Supply Voltage	V <sub>DD</sub>	-	2.4	3.3	3.5	V
Supply Current	I <sub>DD</sub>	V <sub>DD</sub> = 3.3V	80	160	240	mA
"H" Level input	V <sub>IH</sub>	-	0.7 * V <sub>DD</sub>	-	V <sub>DD</sub>	V
"L" Level input	V <sub>IL</sub>	-	GND	-	0.3 * V <sub>DD</sub>	V
Backlight Supply Current	I <sub>LED</sub>	-	30	40	50	mA
Backlight Supply Voltage	V <sub>LED</sub>	I <sub>LED</sub> = 40mA T <sub>OP</sub> = 25°C	22.4	25.6	27.2	V
Backlight Lifetime*	-		30,000	50,000	-	Hrs.

\*Backlight is current driven; do not supply more than 50mA. Backlight lifetime is rated as Hours until **half-brightness**, under normal operating conditions.

## Optical Characteristics

Item	Symbol	Condition	Min.	Typ.	Max.	Unit		
Optimal Viewing Angles	Top	CR ≥ 10	-	80	-	°		
	Bottom		-	80	-	°		
	Left		-	80	-	°		
	Right		-	80	-	°		
Contrast Ratio	CR	-	640	800	-	-		
Luminance	L <sub>V</sub>	I <sub>LED</sub> = 40 mA	680	850	-	cd/m <sup>2</sup>		
Response Time	Rise + Fall	T <sub>R</sub> +T <sub>F</sub>	T <sub>OP</sub> = 25°C		-	30	40	ms
Chromaticity	Red	X <sub>R</sub>	-	0.558	0.598	0.638	-	
		Y <sub>R</sub>	-	0.305	0.345	0.385	-	
	Green	X <sub>G</sub>	-	0.335	0.375	0.415	-	
		Y <sub>G</sub>	-	0.521	0.561	0.601	-	
	Blue	X <sub>B</sub>	-	0.103	0.143	0.183	-	
		Y <sub>B</sub>	-	0.062	0.102	0.142	-	
White	X <sub>W</sub>	-	0.269	0.309	0.349	-		
	Y <sub>W</sub>	-	0.279	0.319	0.355	-		

\* Luminance is directly related to Backlight Supply Current.

## Driver Information

Built-in EK9716B Source Driver: [https://www.newhavendisplay.com/appnotes/datasheets/LCDs/EK9716B\\_v1-1.pdf](https://www.newhavendisplay.com/appnotes/datasheets/LCDs/EK9716B_v1-1.pdf)

Built-in EK73002AB2 Gate Driver: <https://www.newhavendisplay.com/appnotes/datasheets/LCDs/EK73002AB2.pdf>

# Timing Characteristics

## Parallel RGB Input Timing Requirements

Item	Symbol	Min.	Typ.	Max.	Unit	Remark	
DCLK Frequency	Fclk	28.2	29.2	40	MHz	-	
DLCK Period	Tclk	25	34	-	ns	-	
HSYNC	Period Time	Th	908	928	1088	DCLK	Thw + Thbp = 88 DLCK is fixed
	Display Period	Thdisp	800			DCLK	
	Pulse Width	Thw	1	48	87	DCLK	
	Back Porch	Thbp	87	40	1	DCLK	
	Front Porch	Thfp	20	40	200	DCLK	-
VSYNC	Period Time	Tv	517	525	613	H	Tvw + Tvbp = 32 H is fixed
	Display Period	Tvdisp	480			H	
	Pulse Width	Tvw	1	1	3	H	
	Back Porch	Tvbp	31	31	29	H	
	Front Porch	Tvfp	5	13	101	H	-

## DE Mode Timing Diagram

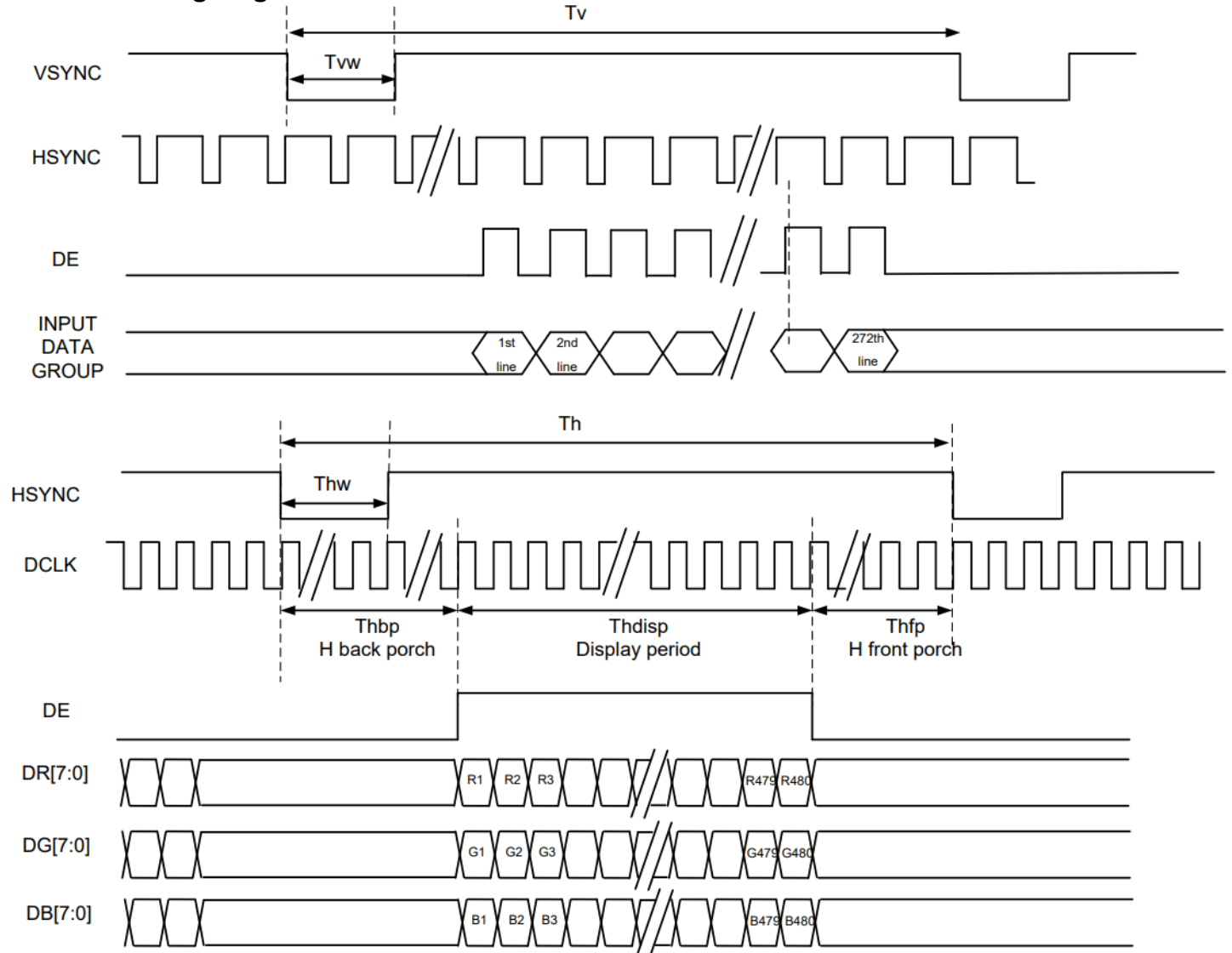

## Input Setup Timing Requirements

Item	Symbol	Min.	Typ.	Max.	Unit	Conditions
V <sub>DD</sub> Power Source Slew Time	T <sub>por</sub>	-	-	20	ms	From 0V to 90% V <sub>DD</sub>
CLK cycle time	T <sub>cph</sub>	25	-	-	ns	-
CLK pulse duty	T <sub>cwh</sub>	40	50	60	%	-
Data setup time	T <sub>dsu</sub>	8	-	-	ns	-
Data hold time	T <sub>dhd</sub>	8	-	-	ns	-
DEN setup time	T <sub>esu</sub>	8	-	-	ns	-
DEN hold time	T <sub>ehd</sub>	8	-	-	ns	-

## Input Setup Timing Diagram

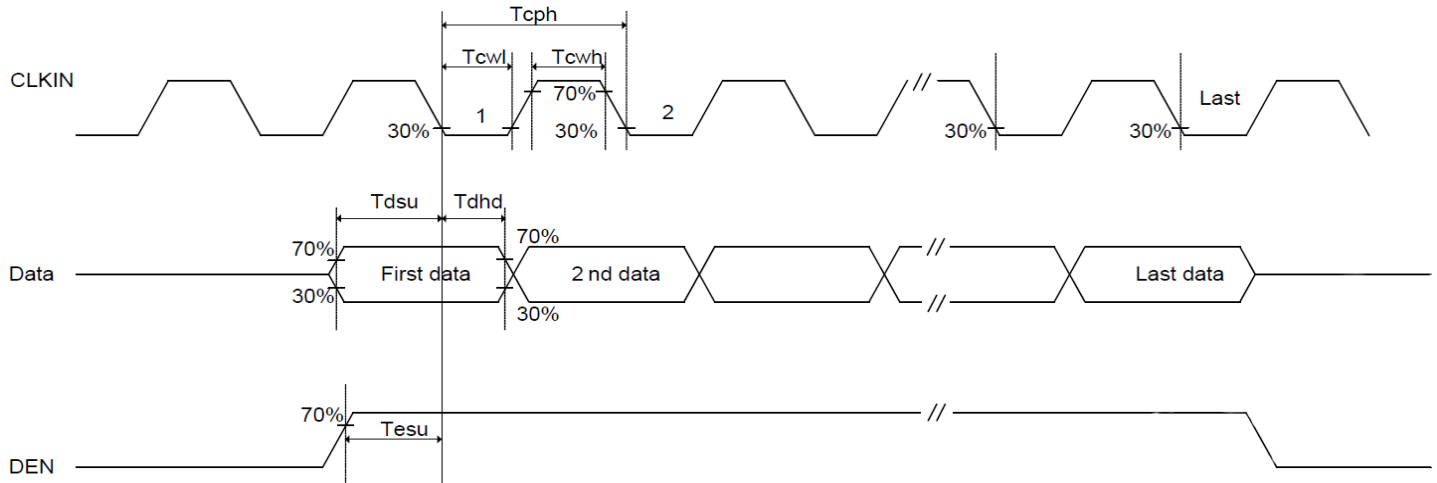

## Power ON/OFF Sequence

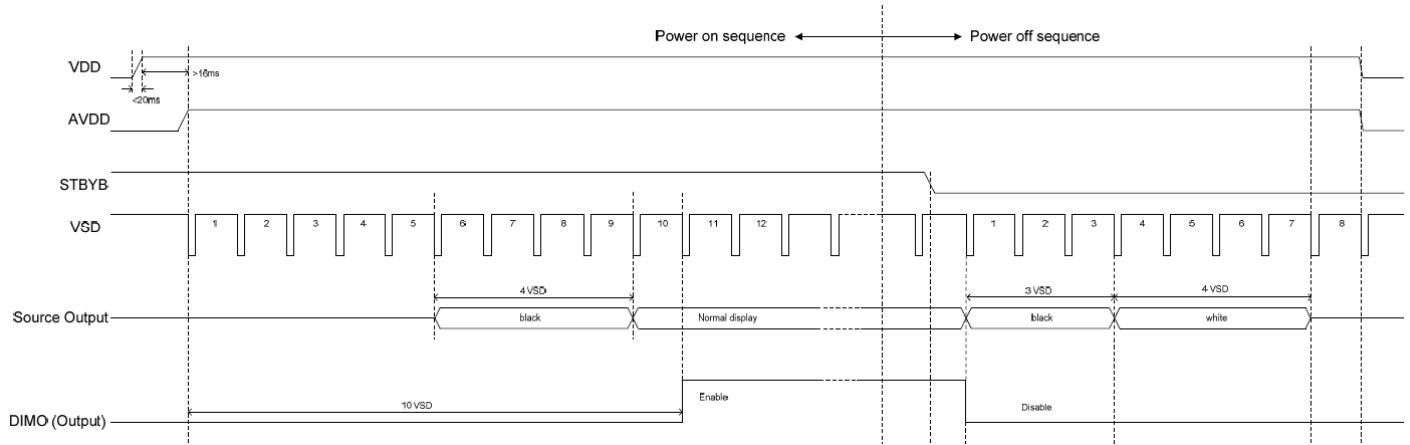

## Enter/Exit Standby Mode Sequence

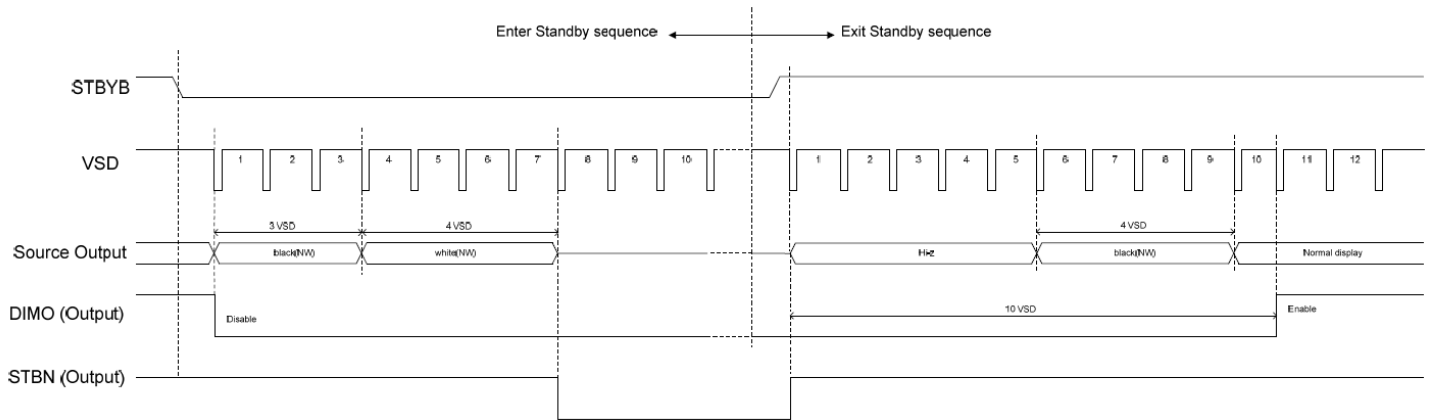

## Quality Information

Test Item	Content of Test	Test Condition	Note
High Temperature storage	Endurance test applying the high storage temperature for a long time.	+80°C, 96 Hrs.	2
Low Temperature storage	Endurance test applying the low storage temperature for a long time.	-30°C, 96 Hrs.	1,2
High Temperature Operation	Endurance test applying the electric stress (voltage & current) and the high thermal stress for a long time.	+70°C, 96 Hrs.	2
Low Temperature Operation	Endurance test applying the electric stress (voltage & current) and the low thermal stress for a long time.	-20°C, 96 Hrs.	1,2
High Temperature / Humidity Operation	Endurance test applying the electric stress (voltage & current) and the high thermal with high humidity stress for a long time.	+60°C, 90% RH , 96 Hrs.	1,2
Thermal Shock resistance	Endurance test applying the electric stress (voltage & current) during a cycle of low and high thermal stress.	-20°C,30min -> 25°C,5min ->70°C,30min -> 25°C,5min = 1 cycle, 10 cycles	-
Vibration test	Endurance test applying vibration to simulate transportation and use.	10-55Hz, 1.5mm amplitude. 2 hours. Each Direction X, Y, Z	3
Static electricity test	Endurance test applying electric static discharge.	Air: V <sub>s</sub> =±6KV, Contact: V <sub>s</sub> =±4KV R <sub>s</sub> =330Ω C <sub>s</sub> =150pF 5 Times	-

**Note 1:** No condensation to be observed.

**Note 2:** Conducted after 4 hours of storage at 25°C, 0%RH.

**Note 3:** Test performed on product itself, not inside a container.

## Precautions for using LCDs/LCMs

See Precautions at [www.newhavendisplay.com/specs/precautions.pdf](http://www.newhavendisplay.com/specs/precautions.pdf)

## Warranty Information

See Terms & Conditions at [http://www.newhavendisplay.com/index.php?main\\_page=terms](http://www.newhavendisplay.com/index.php?main_page=terms)