

NHD-2.8-240320AF-CSXP-F

IPS TFT Liquid Crystal Display Module

NHD-	Newhaven Display
2.8-	2.8" Diagonal
240320-	240 x 320 Pixels (Portrait Mode)
AF-	Model
C-	Built-in Controller
S-	High Brightness White LED Backlight
X-	TFT
P-	IPS, Wide Temperature
F-	FFC ZIF Connection Style

Newhaven Display International, Inc.

2661 Galvin Ct.

Elgin IL, 60124

Ph: 847-844-8795

Fax: 847-844-8796

www.newhavendisplay.com

nhtech@newhavendisplay.com

nhsales@newhavendisplay.com

Document Revision History

Revision	Date	Description	Changed by
-	1/18/19	Initial Release	PB
1	2/19/19	Supply Voltage Updated	SB

Functions and Features

- 240 x 320 pixels
- IPS type, full viewing angles
- High brightness LED backlight
- 3.0V power supply
- 8-bit or 16-bit Parallel MPU interface
- FFC ZIF I/O connection
- Built-in ST7789Vi controller
- 262K colors
- Touch Panel available

SYMBOL	REVISION	DATE

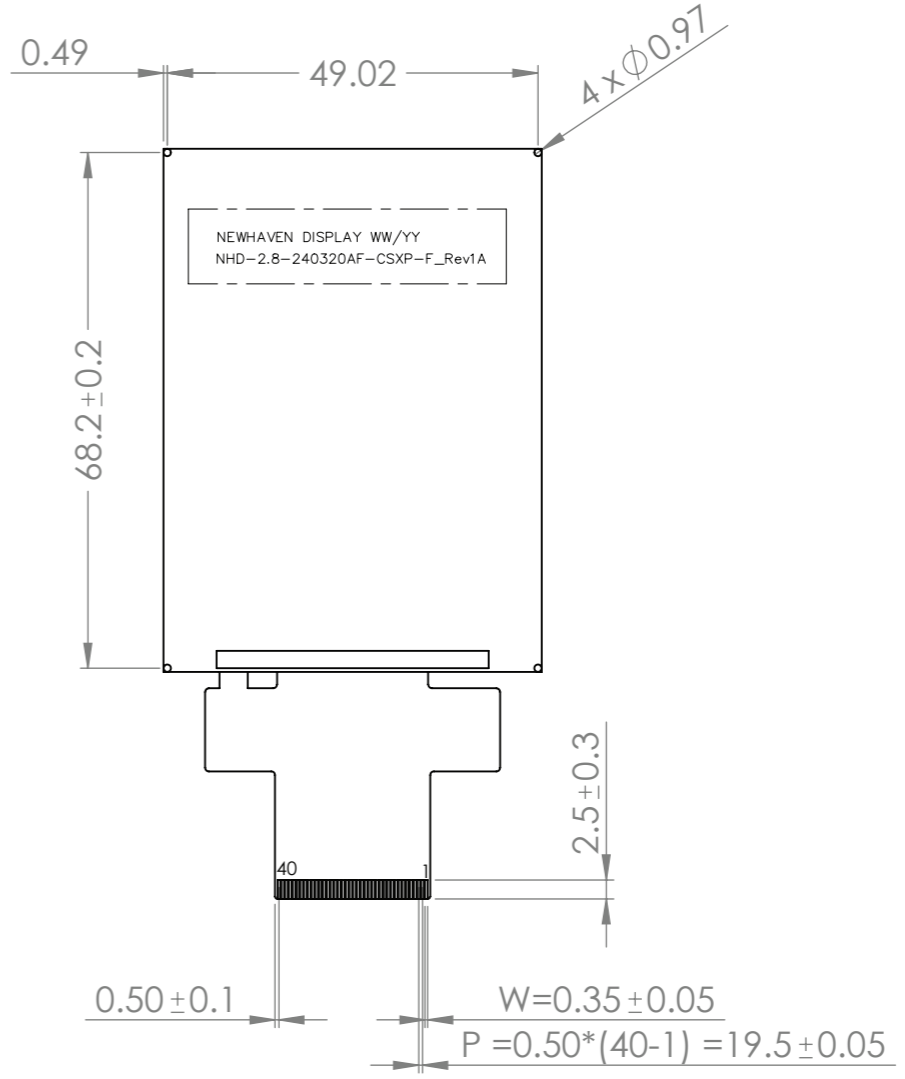
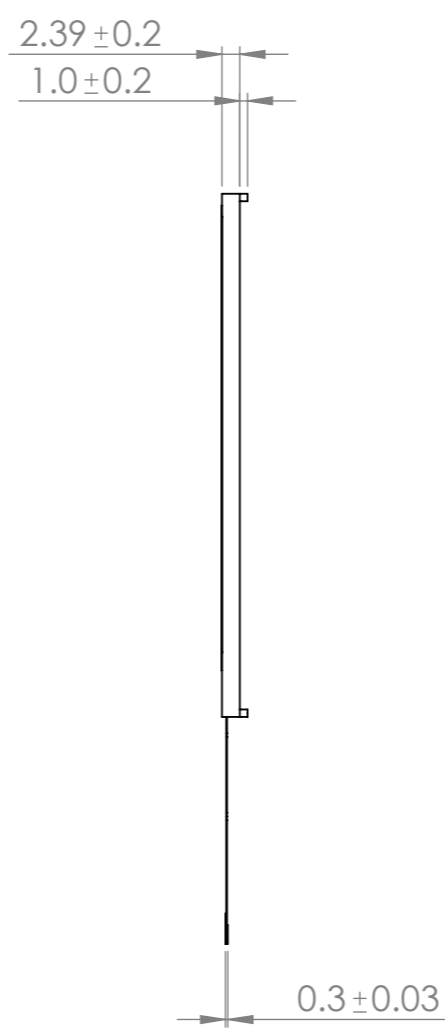
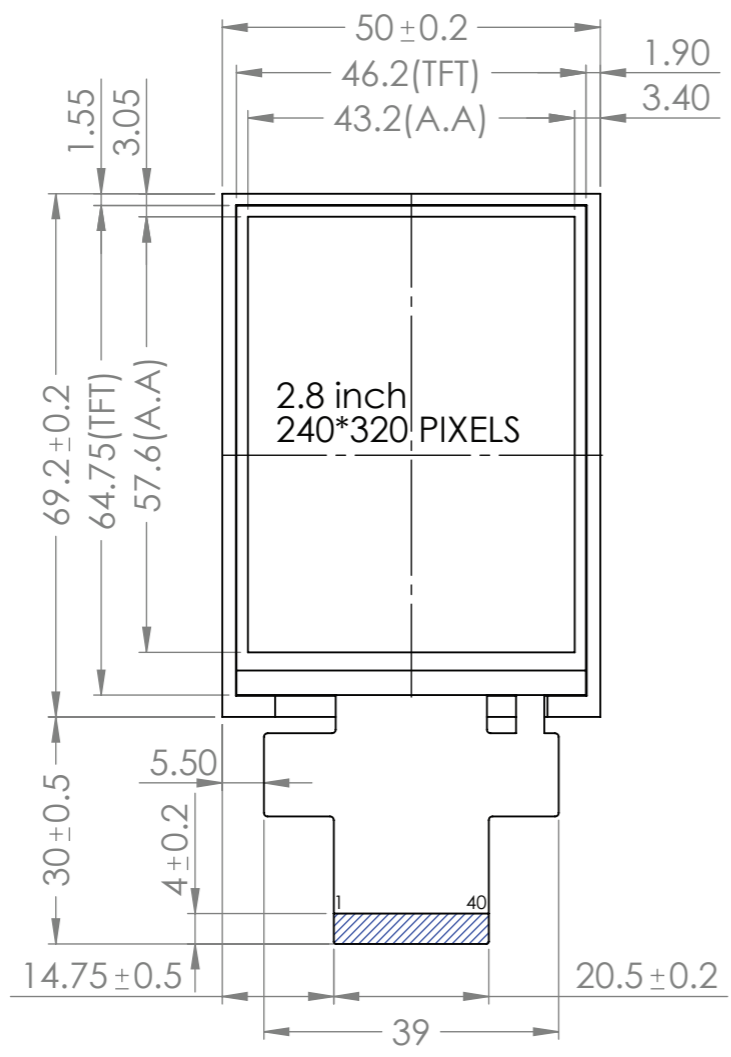

Pin Definitions

PIN No.	SYMBOL
1	GND
2	NC
3	NC
4	NC
5	NC
6	NC
7	VDD
8	IOVDD
9	NC
10	/CS
11	D/C
12	/WR
13	/RD
14	DB0
15	DB1
16	DB2
17	DB3
18	DB4
19	DB5
20	DB6
21	DB7
22	DB8
23	DB9
24	DB10
25	DB11
26	DB12
27	DB13
28	DB14
29	DB15
30	/RES
31	IMO
32	NC
33	GND
34	LEDK1
35	LEDK2
36	LEDK3
37	LEDK4
38	LEDA
39	GND
40	NC

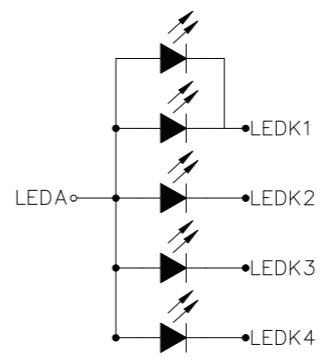

- 1. Display Size: 2.8" TFT
- 2. Optimal View: Full View (IPS)
- 3. Display Mode: Transmissive / Normally Black / Anti-Glare
- 4. Driver IC: ST7789Vi: 8/16Bit Parallel Interface
- 5. Supply Voltage: 2.8V
- 6. Backlight: White LED / 100 mA (Typ) / 3.1V
- 7. Brightness: 600 cd/m² (Typ)
- 8. Film: 3M Brightness Enhancement

STANDARD TOLERANCE:
(UNLESS OTHERWISE SPECIFIED)

LINEAR: ±0.3mm

UNLESS OTHERWISE SPECIFIED:
- DIMENSIONS ARE IN MILLIMETERS
- THIRD ANGLE PROJECTION

DO NOT SCALE DRAWING

THIS DRAWING IS SOLELY THE PROPERTY OF NEWHAVEN DISPLAY INTERNATIONAL, INC. THE INFORMATION IT CONTAINS IS NOT TO BE DISCLOSED, REPRODUCED OR COPIED IN WHOLE OR PART WITHOUT WRITTEN APPROVAL FROM NEWHAVEN DISPLAY.

NEWHAVEN DISPLAY INTERNATIONAL

DRAWING/PART NUMBER: NHD-2.8-240320AF-CSXP-F

REVISION: 1A

SIZE: A3

SCALE: 1:1

SHEET 1 OF 1

DRAWN BY: N. Patel
APPROVED BY: M. LaVine

DRAWN DATE: 9/6/18
APPROVED DATE: 9/10/18

Pin Description

Pin No.	Symbol	External Connection	Function Description
1	GND	Power Supply	Ground
2	NC	-	No Connect
3	NC	-	No Connect
4	NC	-	No Connect
5	NC	-	No Connect
6	NC	-	No Connect
7	V _{DD}	Power Supply	Supply Voltage for LCD (2.8V)
8	IOV _{DD}	Power Supply	Supply Voltage for Logic (Tie to V _{DD})
9	NC	-	No Connect
10	/CS	MPU	Active LOW Chip Select signal (can tie to GND)
11	D/C	MPU	Data / Command selection: '1' = Data ; '0' = Command
12	/WR	MPU	Active LOW Write signal
13	/RD	MPU	Active LOW Read signal
14	DB0	MPU	Bi-directional data bus 8-bit: use DB8-DB15 16-bit: use DB0-DB15
15	DB1	MPU	
16	DB2	MPU	
17	DB3	MPU	
18	DB4	MPU	
19	DB5	MPU	
20	DB6	MPU	
21	DB7	MPU	
22	DB8	MPU	
23	DB9	MPU	
24	DB10	MPU	
25	DB11	MPU	
26	DB12	MPU	
27	DB13	MPU	
28	DB14	MPU	
29	DB15	MPU	
30	/RES	MPU	Active LOW Reset signal
31	IM0	MPU	IM0=0: 16-bit i80 IM0=1: 8-bit i80
32	NC	-	No Connect
33	GND	Power Supply	Ground
34	LED-K1	Power Supply	Backlight Cathode (Ground)
35	LED-K2	Power Supply	Backlight Cathode (Ground)
36	LED-K3	Power Supply	Backlight Cathode (Ground)
37	LED-K4	Power Supply	Backlight Cathode (Ground)
38	LED-A	Power Supply	Backlight Anode (100mA @ 3.1V)
39	GND	Power Supply	Ground
40	NC	-	No Connect

Recommended LCD connector: 40-pin, 0.5mm pitch FFC connector

Molex P/N: 54132-4062 or similar

Wiring Diagram

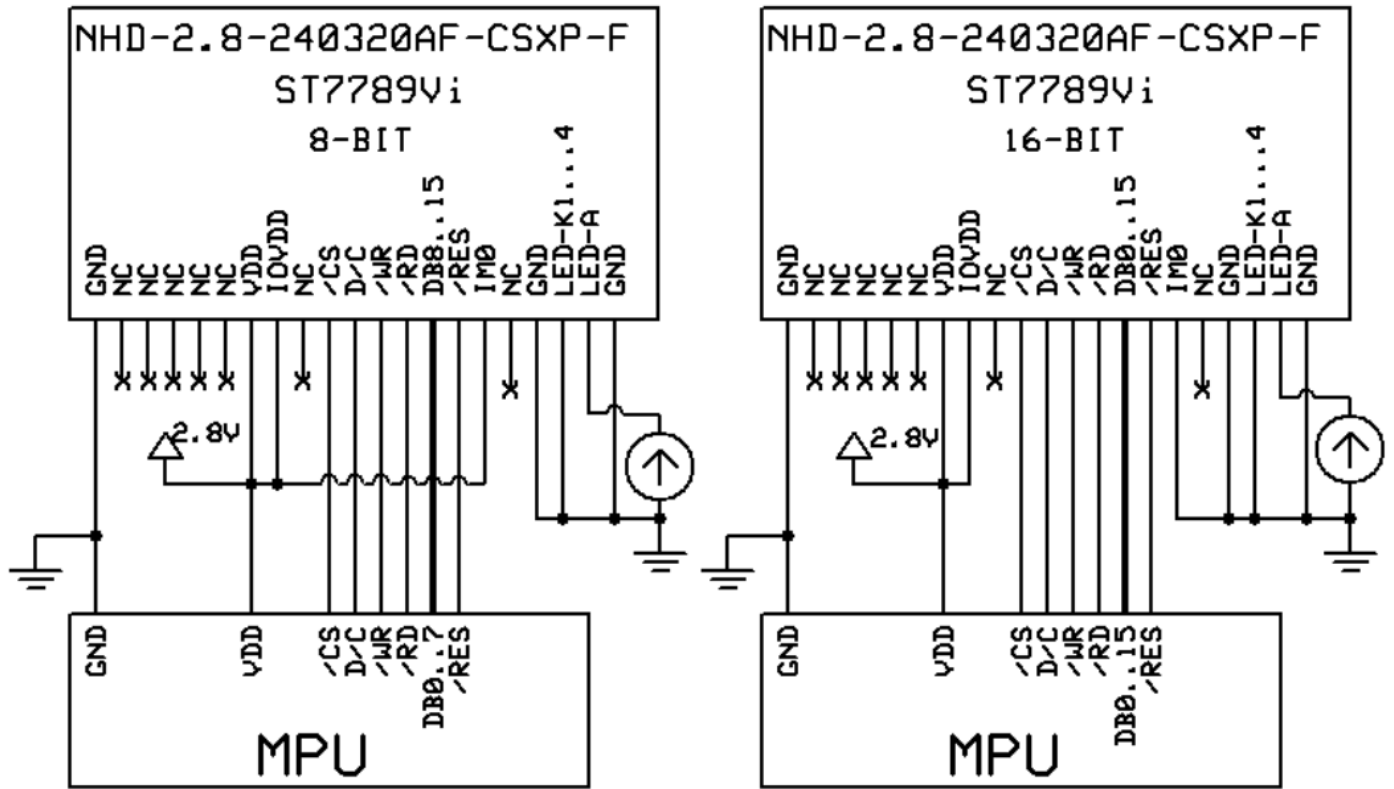

Electrical Characteristics

Item	Symbol	Condition	Min.	Typ.	Max.	Unit
Operating Temperature Range	T _{OP}	Absolute Max	-20	-	+70	°C
Storage Temperature Range	T _{ST}	Absolute Max	-30	-	+80	°C
Supply Voltage for LCD	V _{DD}	-	2.4	2.8	3.3	V
Supply Voltage for Logic	IOV _{DD}	-	1.65	1.8	3.3	V
Supply Current	I _{DD}	V _{DD} = 2.8V	3	9	15	mA
"H" Level input	V _{IH}	-	0.7 * V _{DD}	-	V _{DD}	V
"L" Level input	V _{IL}	-	GND	-	0.3 * V _{DD}	V
"H" Level output	V _{OH}	-	0.8 * V _{DD}	-	V _{DD}	V
"L" Level output	V _{OL}	-	GND	-	0.2 * V _{DD}	V
Backlight Supply Current	I _{LED}	-	80	100	125	mA
Backlight Supply Voltage	V _{LED}	I _{LED} = 100 mA	2.8	3.1	3.4	V
Backlight Lifetime*	-	I _{LED} = 100mA T _{OP} = 25°C	20,000	50,000	-	Hrs.

*Backlight Lifetime is rated as Hours until **half-brightness**, under normal operating conditions. The LED of the backlight is driven by current drain; drive voltage is for reference only. Drive voltage must be selected to ensure backlight current drain is below MAX level stated.

Optical Characteristics

Item	Symbol	Condition	Min.	Typ.	Max.	Unit	
Optimal Viewing Angles	Top	CR ≥ 10	-	80	-	°	
	Bottom		-	80	-	°	
	Left		-	80	-	°	
	Right		-	80	-	°	
Contrast Ratio	CR	-	600	800	-	-	
Luminance	L _V	I _{LED} = 100 mA	480	600	-	cd/m ²	
Response Time	T _R + T _F	T _{OP} = 25°C	-	30	40	Ms	
Chromaticity	Red	X _R	-	0.590	0.630	0.670	-
		Y _R	-	0.296	0.336	0.376	-
	Green	X _G	-	0.267	0.607	0.347	-
		Y _G	-	0.563	0.603	0.643	-
	Blue	X _B	-	0.107	0.147	0.187	-
		Y _B	-	0.012	0.052	0.092	-
	White	X _W	-	0.249	0.289	0.329	-
		Y _W	-	0.270	0.310	0.350	-

Controller Information

Built-in ST7789Vi controller.

Please download specification at <http://www.newhavendisplay.com/appnotes/datasheets/LCDs/ST7789V.pdf>

Table of Commands

Please download specification at <http://www.newhavendisplay.com/appnotes/datasheets/LCDs/ST7789V.pdf>

Timing Characteristics

Parallel 18/16/9/8-bit Interface Timing Characteristics (8080-II system)

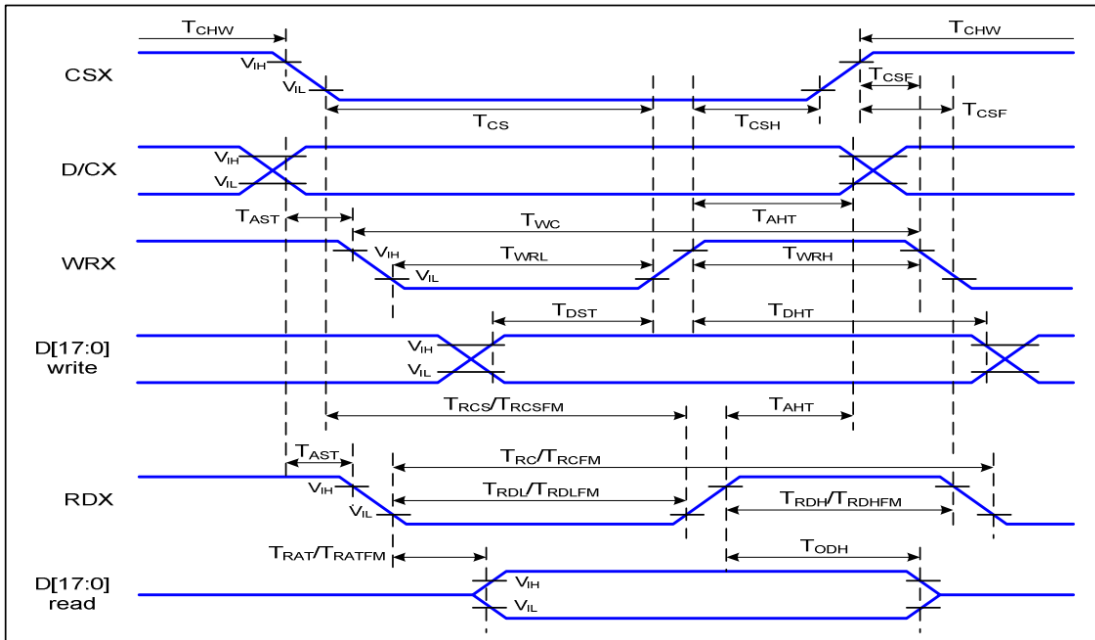

Signal	Symbol	Parameter	Min	Max	Unit	Description
D/CX	T_{AST}	Address setup time	0		ns	-
	T_{AHT}	Address hold time (Write/Read)	10		ns	
CSX	T_{CHW}	Chip select "H" pulse width	0		ns	-
	T_{CS}	Chip select setup time (Write)	15		ns	
	T_{RCS}	Chip select setup time (Read ID)	45		ns	
	T_{RCSFM}	Chip select setup time (Read FM)	355		ns	
	T_{CSF}	Chip select wait time (Write/Read)	10		ns	
	T_{CSH}	Chip select hold time	10		ns	
WRX	T_{WC}	Write cycle	66		ns	-
	T_{WRH}	Control pulse "H" duration	15		ns	
	T_{WRL}	Control pulse "L" duration	15		ns	
RDX (ID)	T_{RC}	Read cycle (ID)	160		ns	When read ID data
	T_{RDH}	Control pulse "H" duration (ID)	90		ns	
	T_{RDL}	Control pulse "L" duration (ID)	45		ns	
RDX (FM)	T_{RCFM}	Read cycle (FM)	450		ns	When read from frame memory
	T_{RDHFM}	Control pulse "H" duration (FM)	90		ns	
	T_{RDLFM}	Control pulse "L" duration (FM)	355		ns	
D[17:0]	T_{DST}	Data setup time	10		ns	For CL=30pF
	T_{DHT}	Data hold time	10		ns	
	T_{RAT}	Read access time (ID)		40	ns	
	T_{RATFM}	Read access time (FM)		340	ns	
	T_{ODH}	Output disable time	20	80	ns	

Reset Timing

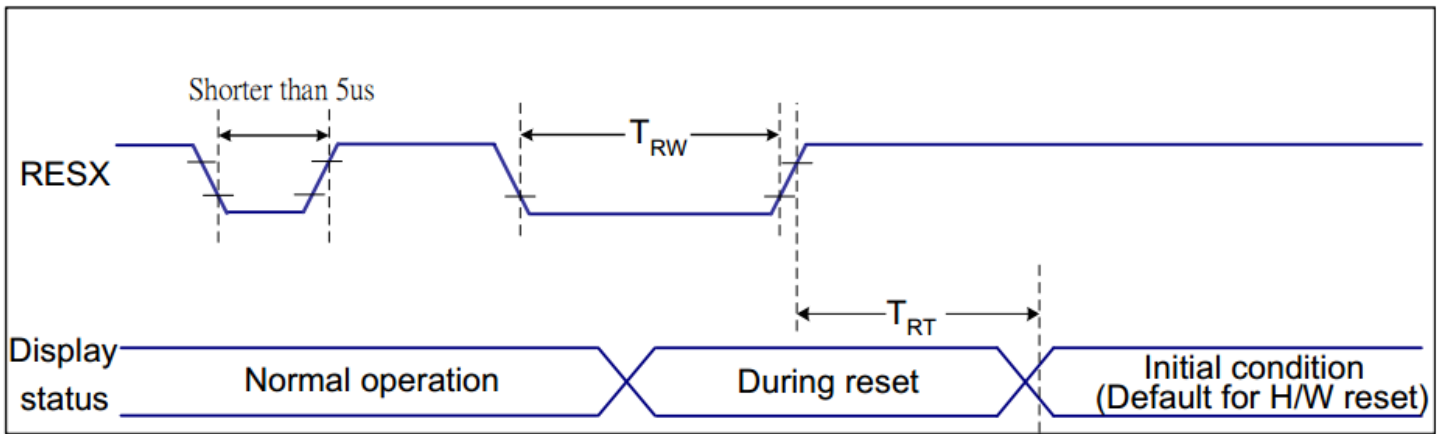

Related Pins	Symbol	Parameter	MIN	MAX	Unit
RESX	TRW	Reset pulse duration	10	-	us
	TRT	Reset cancel	-	5 (Note 1, 5)	ms
				120 (Note 1, 6, 7)	ms

Power ON/OFF Sequence

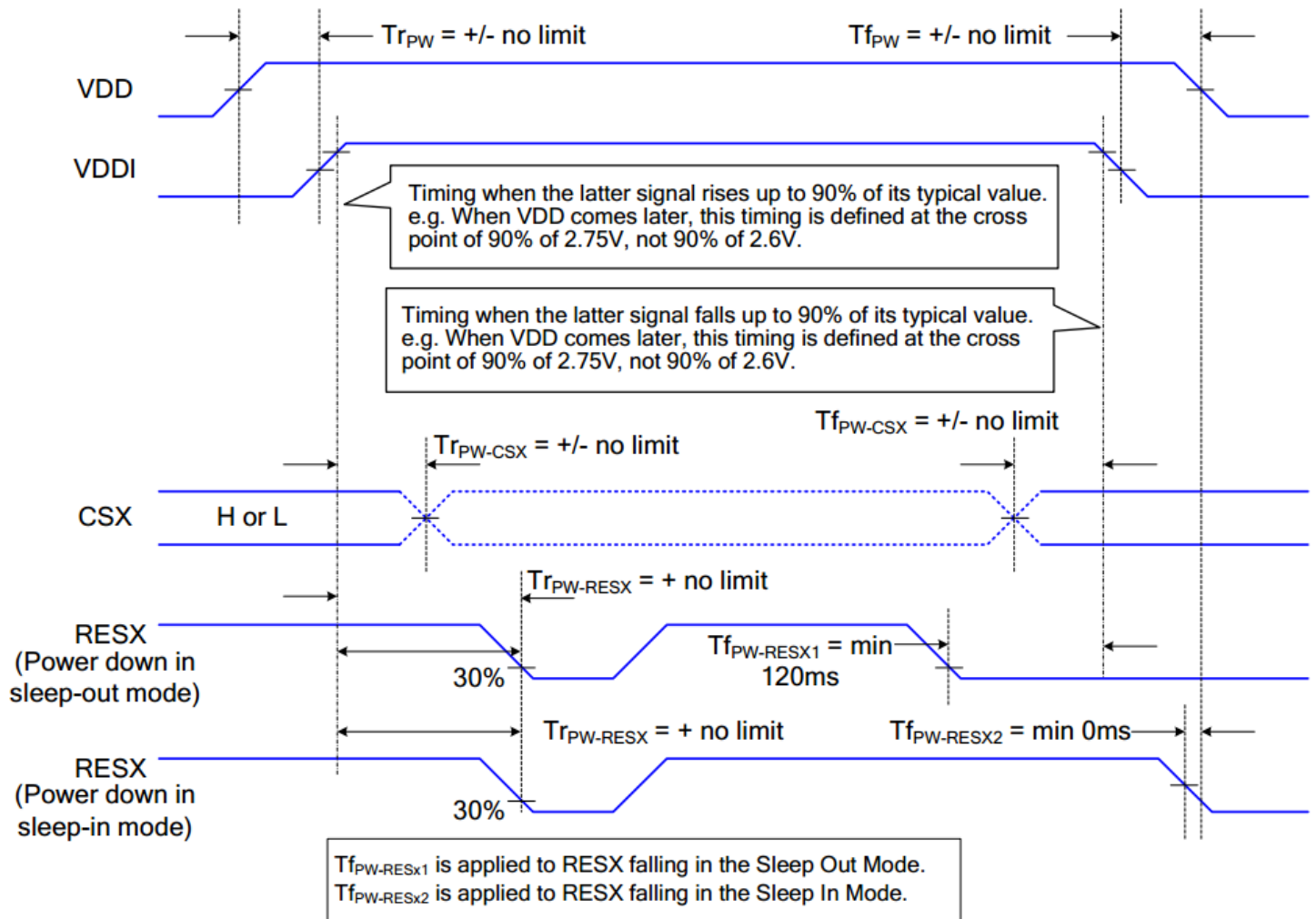

Example Initialization Code

```
/******  
void TFT_28_7789_Write_Command(unsigned int command)  
{  
GPIO_ResetBits(GPIOC, CS1);  
GPIO_ResetBits(GPIOC, RS);  
GPIO_SetBits(GPIOC, nRD);  
GPIO_ResetBits(GPIOC, nWR);  
GPIO_Write(GPIOB, command);  
TFT_delay(10);  
GPIO_SetBits(GPIOC, nWR);  
TFT_delay(1);  
}  
/******  
void TFT_28_7789_Write_Data(unsigned int data1)  
{  
GPIO_Write(GPIOB, data1);  
GPIO_SetBits(GPIOC, RS);  
GPIO_ResetBits(GPIOC, nWR);  
TFT_delay(1);  
GPIO_SetBits(GPIOC, nWR);  
}  
/******  
void TFT_28_7789_Init(void)  
{  
int n;  
GPIO_ResetBits(GPIOC, CS1);  
GPIO_SetBits(GPIOC, nRD);  
GPIO_ResetBits(GPIOC, nWR);  
GPIO_WriteBit(GPIOC, RES, Bit_RESET);  
TFT_delay(100);  
GPIO_WriteBit(GPIOC, RES, Bit_SET);  
TFT_delay(100);  
TFT_28_7789_Write_Command(0x0011); //exit SLEEP mode  
TFT_delay(100);  
  
TFT_28_7789_Write_Command(0x0036);  
TFT_28_7789_Write_Data(0x0080); //MADCTL: memory data access control  
TFT_28_7789_Write_Command(0x003A);  
TFT_28_7789_Write_Data(0x0066); //COLMOD: Interface Pixel format  
TFT_28_7789_Write_Command(0x0021); //INVON: Display Inversion ON (setting for IPS)  
TFT_28_7789_Write_Command(0x00B2);  
TFT_28_7789_Write_Data(0x000C);  
TFT_28_7789_Write_Data(0x0C);  
TFT_28_7789_Write_Data(0x00);  
TFT_28_7789_Write_Data(0x33);  
TFT_28_7789_Write_Data(0x33); //PORCTRK: Porch setting  
TFT_28_7789_Write_Command(0x00B7);  
TFT_28_7789_Write_Data(0x0035); //GCTRL: Gate Control  
TFT_28_7789_Write_Command(0x00BB);  
TFT_28_7789_Write_Data(0x002B); //VCOMS: VCOM setting  
TFT_28_7789_Write_Command(0x00C0);  
TFT_28_7789_Write_Data(0x002C); //LCMCTRL: LCM Control  
TFT_28_7789_Write_Command(0x00C2);  
TFT_28_7789_Write_Data(0x0001);  
TFT_28_7789_Write_Data(0xFF); //VDVVRHEN: VDV and VRH Command Enable  
TFT_28_7789_Write_Command(0x00C3);  
TFT_28_7789_Write_Data(0x0011); //VRHS: VRH Set
```

```

TFT_28_7789_Write_Command(0x00C4);
TFT_28_7789_Write_Data(0x0020);//VDVS: VDV Set
TFT_28_7789_Write_Command(0x00C6);
TFT_28_7789_Write_Data(0x000F);//FRCTRL2: Frame Rate control in normal mode
TFT_28_7789_Write_Command(0x00D0);
TFT_28_7789_Write_Data(0x00A4);
TFT_28_7789_Write_Data(0xA1);//PWCTRL1: Power Control 1
TFT_28_7789_Write_Command(0x00E0);
TFT_28_7789_Write_Data(0x00D0);
TFT_28_7789_Write_Data(0x0000);
TFT_28_7789_Write_Data(0x0005);
TFT_28_7789_Write_Data(0x000E);
TFT_28_7789_Write_Data(0x0015);
TFT_28_7789_Write_Data(0x000D);
TFT_28_7789_Write_Data(0x0037);
TFT_28_7789_Write_Data(0x0043);
TFT_28_7789_Write_Data(0x0047);
TFT_28_7789_Write_Data(0x0009);
TFT_28_7789_Write_Data(0x0015);
TFT_28_7789_Write_Data(0x0012);
TFT_28_7789_Write_Data(0x0016);
TFT_28_7789_Write_Data(0x0019);//PVGAMCTRL: Positive Voltage Gamma control
TFT_28_7789_Write_Command(0x00E1);
TFT_28_7789_Write_Data(0x00D0);
TFT_28_7789_Write_Data(0x0000);
TFT_28_7789_Write_Data(0x0005);
TFT_28_7789_Write_Data(0x000D);
TFT_28_7789_Write_Data(0x000C);
TFT_28_7789_Write_Data(0x0006);
TFT_28_7789_Write_Data(0x002D);
TFT_28_7789_Write_Data(0x0044);
TFT_28_7789_Write_Data(0x0040);
TFT_28_7789_Write_Data(0x000E);
TFT_28_7789_Write_Data(0x001C);
TFT_28_7789_Write_Data(0x0018);
TFT_28_7789_Write_Data(0x0016);
TFT_28_7789_Write_Data(0x0019);//NVGAMCTRL: Negative Voltage Gamma control
TFT_28_7789_Write_Command(0x002A);
TFT_28_7789_Write_Data(0x0000);
TFT_28_7789_Write_Data(0x0000);
TFT_28_7789_Write_Data(0x0000);
TFT_28_7789_Write_Data(0x00EF);//X address set
TFT_28_7789_Write_Command(0x002B);
TFT_28_7789_Write_Data(0x0000);
TFT_28_7789_Write_Data(0x0000);
TFT_28_7789_Write_Data(0x0001);
TFT_28_7789_Write_Data(0x003F);//Y address set

TFT_delay(10);
}
/*****/

```

Quality Information

Test Item	Content of Test	Test Condition	Note
High Temperature Storage	Endurance test applying the high storage temperature for a long time.	+80°C, 240hrs	2
Low Temperature Storage	Endurance test applying the low storage temperature for a long time.	-30°C, 240hrs	1,2
High Temperature Operation	Endurance test applying the electric stress (voltage & current) and the high thermal stress for a long time.	+70°C, 120hrs	2
Low Temperature Operation	Endurance test applying the electric stress (voltage & current) and the low thermal stress for a long time.	-20°C, 120hrs	1,2
High Temperature / Humidity Operation	Endurance test applying the electric stress (voltage & current) and the high thermal with high humidity stress for a long time.	+50°C, 90-95% RH, 120hrs	1,2
Thermal Shock resistance	Endurance test applying the electric stress (voltage & current) during a cycle of low and high thermal stress.	-20°C 30min -> 25°C 5min -> 70°C 30min -> 25°C 5min = 1 cycle. For 10 cycles	
Vibration test	Endurance test applying vibration to simulate transportation and use.	10Hz-55Hz, 1.5mm amplitude. 2hrs in each of 3 directions X,Y,Z	3
Static electricity test	Endurance test applying electric static discharge.	Air discharge: ±8KV 10 Times Contact discharge: ±4kv 10 Times	

Note 1: No condensation to be observed.

Note 2: Conducted after 4 hours of storage at 25°C, 0%RH.

Note 3: Test performed on product itself, not inside a container.

Precautions for using LCDs/LCMs

See Precautions at www.newhavendisplay.com/specs/precautions.pdf

Warranty Information

See Terms & Conditions at http://www.newhavendisplay.com/index.php?main_page=terms