

# NHD-0.6-6464G

## Graphic Color OLED Display

NHD-	Newhaven Display
0.6-	0.6" Diagonal Size
6464-	64 x 64 Pixels
G-	OLED Glass

**Newhaven Display International, Inc.**

2661 Galvin Ct.

Elgin IL, 60124

Ph: 847-844-8795

Fax: 847-844-8796

[www.newhavendisplay.com](http://www.newhavendisplay.com)

[nhtech@newhavendisplay.com](mailto:nhtech@newhavendisplay.com)

[nhsales@newhavendisplay.com](mailto:nhsales@newhavendisplay.com)

## Document Revision History

Revision	Date	Description	Changed by
-	1/25/19	Initial Release	ML

## Functions and Features

- 64 x 64 pixel resolution
- Built-in SSD1357 controller
- 4-wire SPI interface
- RoHS compliant

1	2	3	4	5	6	7	8	
				SYMBOL	REVISION			DATE

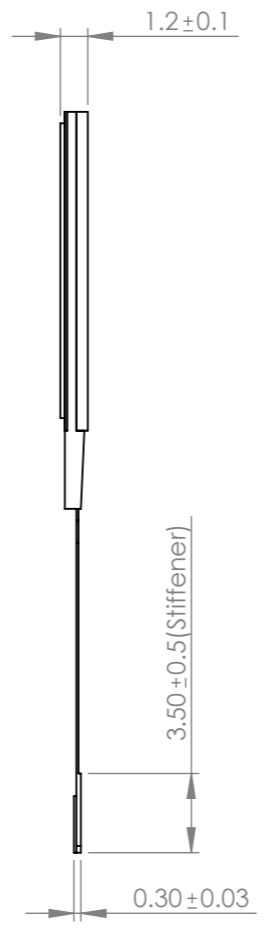
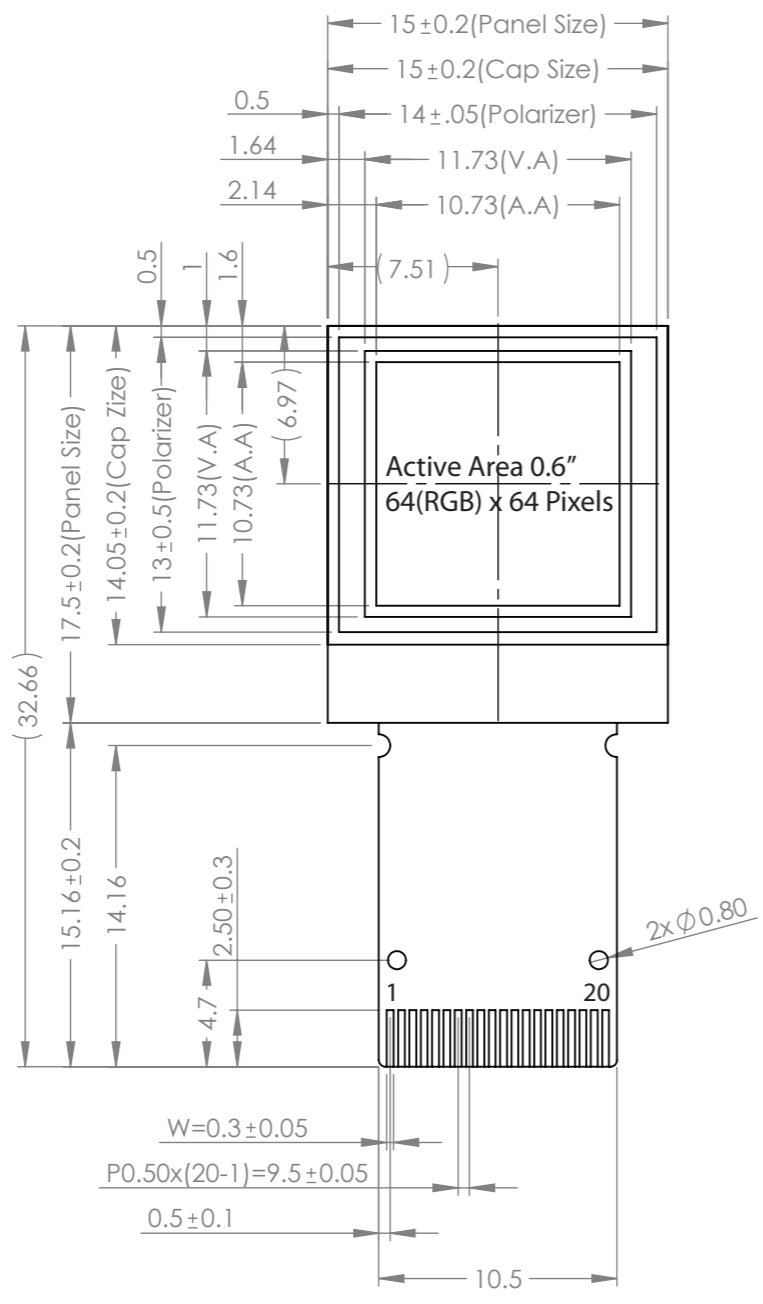

Pin	Symbol
1	N.C.(GND)
2	VCC
3	VCOMH
4	N.C.
5	N.C.
6	N.C.
7	N.C.
8	N.C.
9	N.C.
10	SDIN
11	SCLK
12	N.C.
13	N.C.
14	D/C#
15	RES#
16	CS#
17	IREF
18	VDD
19	VSS
20	N.C.(GND)

- Notes:
1. Display Type: 0.6" Color OLED Glass, FFC Connection
  2. Driver IC: SSD1357
  3. Supply Voltage:
    - Logic (V<sub>DD</sub>) = 3.3V
    - Display (V<sub>CC</sub>) = 12V
  4. Interface: 4-wire SPI
  5. Operating Temp: -40°C - +70°C
  6. Storage Temp: -40°C - +85°C

STANDARD TOLERANCES (UNLESS OTHERWISE SPECIFIED)				REVISION:
				1.0
LINEAR: XX. ±0.3 mm	DRAWING/PART NUMBER:			SIZE:
	NHD-0.6-6464G			A3
UNLESS OTHERWISE SPECIFIED - DIMENSIONS ARE IN MILLIMETERS - THIRD ANGLE PROJECTION	DRAWN BY:	CHECKED BY:	APPROVED BY:	SCALE:
	N. Patel	M. LaVine	M. LaVine	3:1
	DRAWN DATE:	CHECKED DATE:	APPROVED DATE:	
	9/11/18	9/14/18	9/14/18	
DO NOT SCALE DRAWING				SHEET 1 OF 1
THIS DRAWING IS SOLELY THE PROPERTY OF NEWHAVEN DISPLAY INTERNATIONAL, INC. THE INFORMATION IT CONTAINS IS NOT TO BE DISCLOSED, REPRODUCED OR COPIED IN WHOLE OR PART WITHOUT WRITTEN APPROVAL FROM NEWHAVEN DISPLAY.				

## Interface Description

Pin No.	Symbol	External Connection	Function Description
1	NC (GND)	-	No connect (can be tied to Ground)
2	V <sub>CC</sub>	Power Supply	Supply voltage for OLED panel
3	V <sub>COMH</sub>	Power Supply	Voltage output high level for COM signal
4	NC	-	No connect
5	NC	-	No connect
6	NC	-	No connect
7	NC	-	No connect
8	NC	-	No connect
9	NC	-	No connect
10	SDIN	MPU	Serial Data Input Signal
11	SCLK	MPU	Serial Clock Input Signal
12	NC	-	No connect
13	NC	-	No connect
14	D/C#	MPU	Data/Command selection. LOW: Command. HIGH: Data
15	RES#	MPU	Active LOW Reset signal
16	CS#	MPU	Active LOW Chip Select signal
17	I <sub>REF</sub>	Power Supply	Current reference for brightness adjustment
18	V <sub>DD</sub>	Power Supply	Supply voltage for Logic
19	V <sub>SS</sub>	Power Supply	Ground
20	NC (GND)	-	No connect (can be tied to Ground)

**Recommended display connector:** 20pin 0.5mm pitch top contact FFC connector (Molex 52207-2060 or equivalent)

# Wiring Diagram

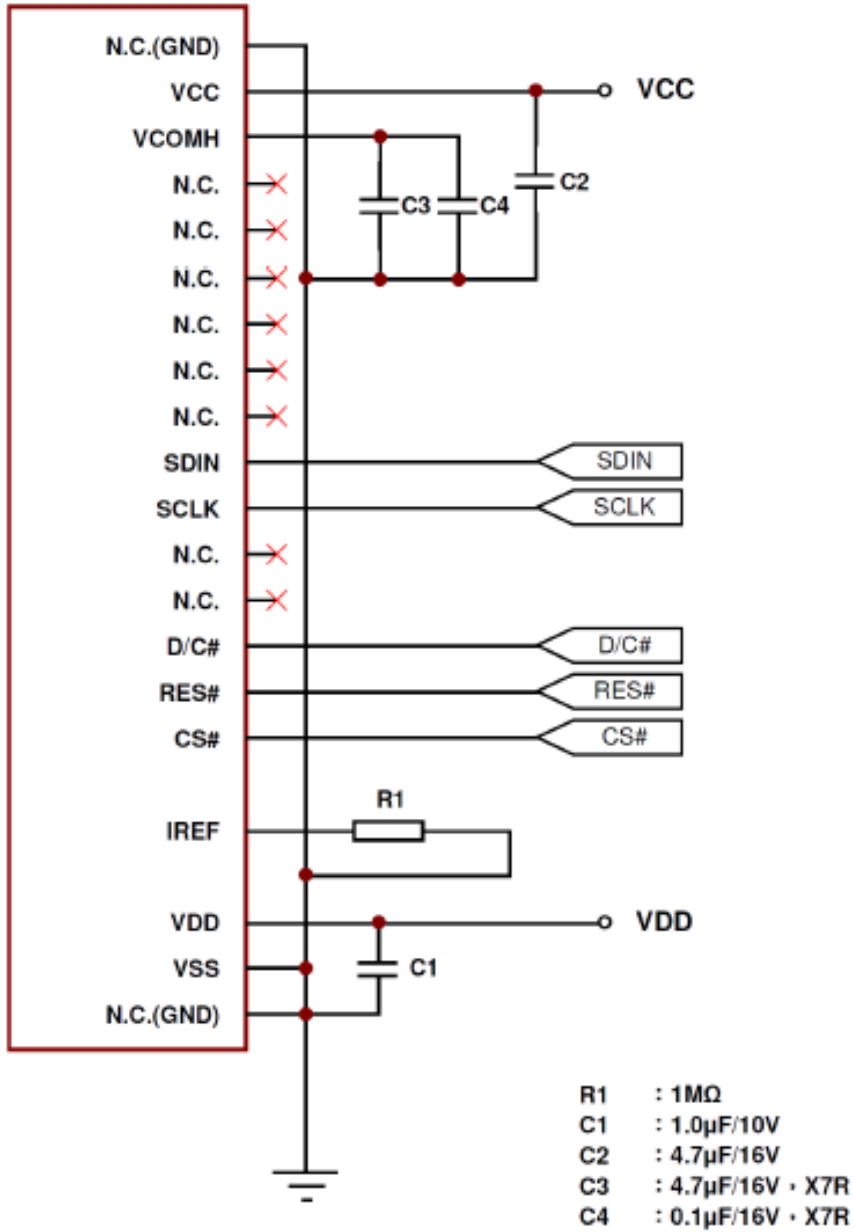

## Electrical Characteristics

Item	Symbol	Condition	Min.	Typ.	Max.	Unit
Operating Temperature Range	T <sub>OP</sub>	Absolute Max	-40	-	+70	°C
Storage Temperature Range	T <sub>ST</sub>	Absolute Max	-40	-	+85	°C
Supply Voltage for Logic	V <sub>DD</sub>	-	1.65	3.0	3.5	V
Supply Voltage for Display	V <sub>CC</sub>	-	11.5	12.0	12.5	V
Supply Current for Logic	I <sub>DD</sub>	V <sub>DD</sub> = 3.0V; 100% On	-	720	800	μA
Supply Current for Display	I <sub>CC</sub>	V <sub>CC</sub> = 12V; 50% On	-	11.5	14.4	mA
		V <sub>CC</sub> = 12V; 100% On	-	20.7	25.9	mA
Supply Current (Sleep)	I <sub>SLEEP</sub>	V <sub>DD</sub> = 3.0V	-	5	20	μA
"H" Level input	V <sub>IH</sub>	-	0.8 * V <sub>DD</sub>	-	V <sub>DD</sub>	V
"L" Level input	V <sub>IL</sub>	-	V <sub>SS</sub>	-	0.2 * V <sub>DD</sub>	V
"H" Level output	V <sub>OH</sub>	-	0.9 * V <sub>DD</sub>	-	V <sub>DD</sub>	V
"L" Level output	V <sub>OL</sub>	-	V <sub>SS</sub>	-	0.1 * V <sub>DD</sub>	V

## Optical Characteristics

Item	Symbol	Condition	Min.	Typ.	Max.	Unit
Optimal Viewing Angles	Top	φY+	80	-	-	°
	Bottom	φY-	80	-	-	°
	Left	θX-	80	-	-	°
	Right	θX+	80	-	-	°
Contrast Ratio	CR	-	-	>10,000:1	-	-
Response Time (rise)	T <sub>R</sub>	-	-	10	-	us
Response Time (fall)	T <sub>F</sub>	-	-	10	-	us
Brightness	L <sub>V</sub>	50% Checkerboard	160	200	-	cd/m <sup>2</sup>
Lifetime	-	200 cd/m <sup>2</sup> , T <sub>OP</sub> =25°C 50% Checkerboard	8,000	-	-	Hrs
		160 cd/m <sup>2</sup> , T <sub>OP</sub> =25°C 50% Checkerboard	10,000	-	-	Hrs

**Note:** Lifetime at typical temperature is based on accelerated high-temperature operation. Lifetime is tested at average 50% pixels on and is rated as Hours until **Half-Brightness**. The Display OFF command can be used to extend the lifetime of the display.

Luminance of active pixels will degrade faster than inactive pixels. Residual (burn-in) images may occur. To avoid this, every pixel should be illuminated uniformly.

## Controller information

Built-in SSD1357 controller.

Please download specification at [www.newhavendisplay.com/appnotes/datasheets/OLEDs/SSD1357.pdf](http://www.newhavendisplay.com/appnotes/datasheets/OLEDs/SSD1357.pdf)

For the full command table and descriptions, please download the following:

[www.newhavendisplay.com/appnotes/datasheets/OLEDs/SSD1357\\_Commands.pdf](http://www.newhavendisplay.com/appnotes/datasheets/OLEDs/SSD1357_Commands.pdf)

## Table of Commands

Fundamental Command Table											
D/C#	Hex	D7	D6	D5	D4	D3	D2	D1	D0	Command	Description
0	15	0	0	0	1	0	1	0	1	Set Column Address	A[6:0]: Start Address. [reset=0] B[6:0]: End Address. [reset=127] Range from 0 to 127
1	A[6:0]	*	A <sub>6</sub>	A <sub>5</sub>	A <sub>4</sub>	A <sub>3</sub>	A <sub>2</sub>	A <sub>1</sub>	A <sub>0</sub>		
1	B[6:0]	*	B <sub>6</sub>	B <sub>5</sub>	B <sub>4</sub>	B <sub>3</sub>	B <sub>2</sub>	B <sub>1</sub>	B <sub>0</sub>		
0	75	0	1	1	1	0	1	0	1	Set Row Address	A[6:0]: Start Address. [reset=0] B[6:0]: End Address. [reset=127] Range from 0 to 127
1	A[6:0]	*	A <sub>6</sub>	A <sub>5</sub>	A <sub>4</sub>	A <sub>3</sub>	A <sub>2</sub>	A <sub>1</sub>	A <sub>0</sub>		
1	B[6:0]	*	B <sub>6</sub>	B <sub>5</sub>	B <sub>4</sub>	B <sub>3</sub>	B <sub>2</sub>	B <sub>1</sub>	B <sub>0</sub>		
0	5C	0	1	0	1	1	1	0	0	Write RAM Command	Enable MCU to write Data into RAM
0	5D	0	1	0	1	1	1	0	1	Read RAM Command	Enable MCU to read Data from RAM
0	A0	1	0	1	0	0	0	0	0	Set Re-map / Color Depth (Display RAM to Panel)	A[0]=0b, Horizontal address increment [reset] A[0]=1b, Vertical address increment
1	A[7:0]	A <sub>7</sub>	A <sub>6</sub>	A <sub>5</sub>	A <sub>4</sub>	A <sub>3</sub>	A <sub>2</sub>	A <sub>1</sub>	A <sub>0</sub>		
1	B[7:0]	0	0	0	0	0	0	0	0		
											<p>A[1]=0b, Column address 0 is mapped to SEG0 [reset] A[1]=1b, Column address 127 is mapped to SEG0</p> <p>A[2]=0b, Color sequence: A <math>\boxtimes</math> B <math>\boxtimes</math> C [reset] A[2]=1b, Color sequence is swapped: C <math>\boxtimes</math> B <math>\boxtimes</math> A</p> <p>A[3]=0b, Reserved [reset] A[3]=1b, Reserved</p> <p>A[4]=0b, Scan from COM0 to COM[N-1] [reset] A[4]=1b, Scan from COM[N-1] to COM0. Where N is the Multiplex ratio.</p> <p>A[5]=0b, Disable COM Split Odd Even A[5]=1b, Enable COM Split Odd Even [reset]</p> <p>A[7:6] Set Color Depth, 00b: 256color 01b: 65k color [reset] 10b: 262k color 11b Pseudo 262k color, 16-bit format 2</p> <p>Refer to Product Preview Table 6-6 for details</p>

Fundamental Command Table											
D/C#	Hex	D7	D6	D5	D4	D3	D2	D1	D0	Command	Description
0 1	A1 A[6:0]	1 *	0 A <sub>6</sub>	1 A <sub>5</sub>	0 A <sub>4</sub>	0 A <sub>3</sub>	0 A <sub>2</sub>	0 A <sub>1</sub>	1 A <sub>0</sub>	Set Display Start Line	Set vertical scroll by RAM from 0~127. [reset=00h]
0 1	A2 A[6:0]	1 *	0 A <sub>6</sub>	1 A <sub>5</sub>	0 A <sub>4</sub>	0 A <sub>3</sub>	0 A <sub>2</sub>	1 A <sub>1</sub>	0 A <sub>0</sub>	Set Display Offset	Set vertical scroll by Row from 0-127. [reset=00h]
0	A4~A7	1	0	1	0	0	1	X <sub>1</sub>	X <sub>0</sub>	Set Display Mode	A4h: All OFF A5h: All ON (All pixels have GS63) A6h : Reset to normal display [reset] A7h: Inverse Display (GS0 -> GS63, GS1 -> GS62, ...)
0	AE~AF	1	0	1	0	1	1	1	X <sub>0</sub>	Set Sleep mode ON/OFF	A Eh = Sleep mode On (Display OFF) A Fh = Sleep mode OFF (Display ON)
0 1	B1 A[7:0]	1 A <sub>7</sub>	0 A <sub>6</sub>	1 A <sub>5</sub>	1 A <sub>4</sub>	0 A <sub>3</sub>	0 A <sub>2</sub>	0 A <sub>1</sub>	1 A <sub>0</sub>	Set Reset (Phase 1) / Pre-charge (Phase 2) period	A[3:0] Phase 1 period of 2~30 DCLK(s) clocks [reset=0100b] A[3:0]: 0 invalid 1 = 2 DCLKs 2 = 4 DCLKs : 15 = 30DCLKs  A[7:4] Phase 2 period of 2~30 DCLK(s) clocks [reset=1000b] A[7:4]: 0 invalid 1 = 2 DCLKs 2 = 4 DCLKs : 15 =30DCLKs  Note ( <sup>1</sup> ) 0 DCLK is invalid in phase 1 & phase 2

Fundamental Command Table																																	
D/C#	Hex	D7	D6	D5	D4	D3	D2	D1	D0	Command	Description																						
0	B3	1	0	1	1	0	0	1	1	Front Clock Divider (DivSet)/ Oscillator Frequency	A[3:0] [reset=0000b], divide by DIVSET where <table border="1" style="margin-left: 20px;"> <thead> <tr> <th>A[3:0]</th> <th>DIVSET</th> </tr> </thead> <tbody> <tr><td>0000</td><td>divide by 1</td></tr> <tr><td>0001</td><td>divide by 2</td></tr> <tr><td>0010</td><td>divide by 4</td></tr> <tr><td>0011</td><td>divide by 8</td></tr> <tr><td>0100</td><td>divide by 16</td></tr> <tr><td>0101</td><td>divide by 32</td></tr> <tr><td>0110</td><td>divide by 64</td></tr> <tr><td>0111</td><td>divide by 128</td></tr> <tr><td>1000</td><td>divide by 256</td></tr> <tr><td>&gt;=1001</td><td>invalid</td></tr> </tbody> </table>	A[3:0]	DIVSET	0000	divide by 1	0001	divide by 2	0010	divide by 4	0011	divide by 8	0100	divide by 16	0101	divide by 32	0110	divide by 64	0111	divide by 128	1000	divide by 256	>=1001	invalid
A[3:0]	DIVSET																																
0000	divide by 1																																
0001	divide by 2																																
0010	divide by 4																																
0011	divide by 8																																
0100	divide by 16																																
0101	divide by 32																																
0110	divide by 64																																
0111	divide by 128																																
1000	divide by 256																																
>=1001	invalid																																
1	A[7:0]	A <sub>7</sub>	A <sub>6</sub>	A <sub>5</sub>	A <sub>4</sub>	A <sub>3</sub>	A <sub>2</sub>	A <sub>1</sub>	A <sub>0</sub>	A[7:4] Oscillator frequency, frequency increases as level increases [reset=0010b]																							
0	B6	1	0	1	1	0	1	0	0	Set Second Pre-charge Period	A[3:0] Set Second Pre-charge Period  0000b invalid 0001b 1 DCLKS 0010b 2 DCLKS ..... 1000 8 DCLKS [reset] ..... 1111 15 DCLKS																						
1	A[3:0]	0	0	0	0	A <sub>3</sub>	A <sub>2</sub>	A <sub>1</sub>	A <sub>0</sub>																								
0	B8	1	0	1	1	1	0	0	0	Master Look Up Table for Gray Scale Pulse width (Color A,B,C)	The next 63 data bytes define Gray Scale (GS) Table by setting the gray scale pulse width in unit of DCLK's (ranges from 0d ~ 180d).  A1[7:0]: Gamma Setting for GS1, A2[7:0]: Gamma Setting for GS2, ..... A62[7:0]: Gamma Setting for GS62, A63[7:0]: Gamma Setting for GS63  <b>Note</b> ( <sup>1</sup> ) 0 ∅ Setting of GS1 < Setting of GS2 < Setting of GS3..... < Setting of GS62 < Setting of GS63 ( <sup>2</sup> ) GS0 does not has pre-charge and current drive stages. ( <sup>3</sup> ) GS1 can be set as only pre-charge but no current drive stage by input gamma setting for GS1 equals 0. ( <sup>4</sup> ) When command B8h is input only, color A, B, C will follow the master LUT. ( <sup>5</sup> ) When command BCh is input, it selects individual LUT for color A, GS1~31A; When command BDh is input, it selects individual LUT for color C, GS1~31C ( <sup>6</sup> ) To select individual LUT for color B, A and C, command B8h should be input before command BCh and BDh,																						
1	A1[7:0]	A1 <sub>7</sub>	A1 <sub>6</sub>	A1 <sub>5</sub>	A1 <sub>4</sub>	A1 <sub>3</sub>	A1 <sub>2</sub>	A1 <sub>1</sub>	A1 <sub>0</sub>																								
1	A2[7:0]	A2 <sub>7</sub>	A2 <sub>6</sub>	A2 <sub>5</sub>	A2 <sub>4</sub>	A2 <sub>3</sub>	A2 <sub>2</sub>	A2 <sub>1</sub>	A2 <sub>0</sub>																								
1	.	.	.	.	.	.	.	.	.																								
1	.	.	.	.	.	.	.	.	.																								
1	.	.	.	.	.	.	.	.	.																								
1	A62[7:0]	A62 <sub>7</sub>	A62 <sub>6</sub>	A62 <sub>5</sub>	A62 <sub>4</sub>	A62 <sub>3</sub>	A62 <sub>2</sub>	A62 <sub>1</sub>	A62 <sub>0</sub>																								
1	A63[7:0]	A63 <sub>7</sub>	A63 <sub>6</sub>	A63 <sub>5</sub>	A63 <sub>4</sub>	A63 <sub>3</sub>	A63 <sub>2</sub>	A63 <sub>1</sub>	A63 <sub>0</sub>																								

Fundamental Command Table																															
D/C#	Hex	D7	D6	D5	D4	D3	D2	D1	D0	Command	Description																				
0	B9	1	0	1	1	1	0	0	1	Use Built-in Linear LUT [reset= linear]	Reset to default Look Up Table:																				
											<table border="1"> <thead> <tr> <th>Color A</th> <th>Color B</th> <th>Color C</th> </tr> </thead> <tbody> <tr> <td>GS1A = 0 DCLK</td> <td>GS1B = 0 DCLK</td> <td>GS1C = 0 DCLK</td> </tr> <tr> <td>GS2A = 4 DCLK</td> <td>GS2B = 2 DCLK</td> <td>GS2C = 4 DCLK</td> </tr> <tr> <td>GS3A = 8 DCLK</td> <td>GS3B = 4 DCLK</td> <td>GS3C = 8 DCLK</td> </tr> <tr> <td>...</td> <td>...</td> <td>...</td> </tr> <tr> <td>GS31A = 120 DCLK</td> <td>GS62B = 122 DCLK</td> <td>GS31C = 120 DCLK</td> </tr> <tr> <td></td> <td>GS63B = 124 DCLK</td> <td></td> </tr> </tbody> </table>	Color A	Color B	Color C	GS1A = 0 DCLK	GS1B = 0 DCLK	GS1C = 0 DCLK	GS2A = 4 DCLK	GS2B = 2 DCLK	GS2C = 4 DCLK	GS3A = 8 DCLK	GS3B = 4 DCLK	GS3C = 8 DCLK	...	...	...	GS31A = 120 DCLK	GS62B = 122 DCLK	GS31C = 120 DCLK		GS63B = 124 DCLK
Color A	Color B	Color C																													
GS1A = 0 DCLK	GS1B = 0 DCLK	GS1C = 0 DCLK																													
GS2A = 4 DCLK	GS2B = 2 DCLK	GS2C = 4 DCLK																													
GS3A = 8 DCLK	GS3B = 4 DCLK	GS3C = 8 DCLK																													
...	...	...																													
GS31A = 120 DCLK	GS62B = 122 DCLK	GS31C = 120 DCLK																													
	GS63B = 124 DCLK																														
0 1	BB A[4:0]	1 0	0 0	1 0	1 A <sub>4</sub>	1 A <sub>3</sub>	0 A <sub>2</sub>	1 A <sub>1</sub>	1 A <sub>0</sub>	Set Pre-charge voltage	Set pre-charge voltage level.[reset = 11110b]																				
											<table border="1"> <thead> <tr> <th>A[4:0]</th> <th>Hex code</th> <th>pre-charge voltage</th> </tr> </thead> <tbody> <tr> <td>00000</td> <td>00h</td> <td>0.10 x V<sub>CC</sub></td> </tr> <tr> <td>:</td> <td>:</td> <td>:</td> </tr> <tr> <td>11110</td> <td>1Eh</td> <td>0.50 x V<sub>CC</sub> [reset]</td> </tr> <tr> <td>11111</td> <td>1Fh</td> <td>0.5133 x V<sub>CC</sub></td> </tr> </tbody> </table> <p><b>Note</b>  <sup>(1)</sup>Pre-charge voltage level must be smaller than COM deselect voltage level</p>	A[4:0]	Hex code	pre-charge voltage	00000	00h	0.10 x V <sub>CC</sub>	:	:	:	11110	1Eh	0.50 x V <sub>CC</sub> [reset]	11111	1Fh	0.5133 x V <sub>CC</sub>					
A[4:0]	Hex code	pre-charge voltage																													
00000	00h	0.10 x V <sub>CC</sub>																													
:	:	:																													
11110	1Eh	0.50 x V <sub>CC</sub> [reset]																													
11111	1Fh	0.5133 x V <sub>CC</sub>																													
0 1 1 1 1 1 1	BC A1[7:0] A2[7:0] . . . A30[7:0] A31[7:0]	1 A1 <sub>7</sub> A2 <sub>7</sub> . . . A30 <sub>7</sub> A31 <sub>7</sub>	0 A1 <sub>6</sub> A2 <sub>6</sub> . . . A30 <sub>6</sub> A31 <sub>6</sub>	1 A1 <sub>5</sub> A2 <sub>5</sub> . . . A30 <sub>5</sub> A31 <sub>5</sub>	1 A1 <sub>4</sub> A2 <sub>4</sub> . . . A30 <sub>4</sub> A31 <sub>4</sub>	1 A1 <sub>3</sub> A2 <sub>3</sub> . . . A30 <sub>3</sub> A31 <sub>3</sub>	1 A1 <sub>2</sub> A2 <sub>2</sub> . . . A30 <sub>2</sub> A31 <sub>2</sub>	0 A1 <sub>1</sub> A2 <sub>1</sub> . . . A30 <sub>1</sub> A31 <sub>1</sub>	0 A1 <sub>0</sub> A2 <sub>0</sub> . . . A30 <sub>0</sub> A31 <sub>0</sub>	Individual Look Up Table for Gray Scale Pulse width (Color A)	The next 31 data bytes define Gray Scale (GS) Table by setting the gray scale pulse width in unit of DCLK's (ranges from 0d ~ 180d) for color A.																				
											<p>A1[7:0]: Gamma Setting for GS1A,  A2[7:0]: Gamma Setting for GS2A,  :  A62[7:0]: Gamma Setting for GS30A,  A63[7:0]: Gamma Setting for GS31A</p> <p><b>Note</b>  <sup>(1)</sup> 0 ≠ Setting of GS1 &lt; Setting of GS2 &lt; Setting of GS3..... &lt; Setting of GS30 &lt; Setting of GS31  <sup>(2)</sup> GS0 does not has pre-charge and current drive stages.  <sup>(3)</sup> GS1 can be set as only pre-charge but no current drive stage by input gamma setting for GS1 equals 0.  <sup>(4)</sup> When command B8h is input, it selects one LUT for color A, B and C. i.e. GS1~31A, GS1~63B and GS1~31C are updated.  <sup>(5)</sup> Command B8h should be input before command BCh and BDh to select individual LUT for color B, A and C.</p>																				

Fundamental Command Table																													
D/C#	Hex	D7	D6	D5	D4	D3	D2	D1	D0	Command	Description																		
0	BD	1	0	1	1	1	1	0	1	Individual Look Up Table for Gray Scale Pulse width (Color C)	The next 31 data bytes define Gray Scale (GS) Table by setting the gray scale pulse width in unit of DCLK's (ranges from 0d ~ 180d) for color C.  A1[7:0]: Gamma Setting for GS1C, A2[7:0]: Gamma Setting for GS2C, . . . A62[7:0]: Gamma Setting for GS30C, A63[7:0]: Gamma Setting for GS31C																		
1	A1[7:0]	A1 <sub>7</sub>	A1 <sub>6</sub>	A1 <sub>5</sub>	A1 <sub>4</sub>	A1 <sub>3</sub>	A1 <sub>2</sub>	A1 <sub>1</sub>	A1 <sub>0</sub>																				
1	A2[7:0]	A2 <sub>7</sub>	A2 <sub>6</sub>	A2 <sub>5</sub>	A2 <sub>4</sub>	A2 <sub>3</sub>	A2 <sub>2</sub>	A2 <sub>1</sub>	A2 <sub>0</sub>																				
1	.	.	.	.	.	.	.	.	.																				
1	.	.	.	.	.	.	.	.	.																				
1	.	.	.	.	.	.	.	.	.																				
1	A30[7:0]	A30 <sub>7</sub>	A30 <sub>6</sub>	A30 <sub>5</sub>	A30 <sub>4</sub>	A30 <sub>3</sub>	A30 <sub>2</sub>	A30 <sub>1</sub>	A30 <sub>0</sub>																				
1	A31[7:0]	A31 <sub>7</sub>	A31 <sub>6</sub>	A31 <sub>5</sub>	A31 <sub>4</sub>	A31 <sub>3</sub>	A31 <sub>2</sub>	A31 <sub>1</sub>	A31 <sub>0</sub>																				
											<b>Note</b> <sup>(1)</sup> 0 $\square$ Setting of GS1 < Setting of GS2 < Setting of GS3..... < Setting of GS30 < Setting of GS31 <sup>(2)</sup> GS0 does not has pre-charge and current drive stages. <sup>(3)</sup> GS1 can be set as only pre-charge but no current drive stage by input gamma setting for GS1 equals 0. <sup>(4)</sup> When command B8h is input, it selects one LUT for color A, B and C. i.e. GS1~31A, GS1~63B and GS1~31C are updated. <sup>(5)</sup> Command B8h should be input before command BCh and BDh to select individual LUT for color B, A and C.																		
0	BE	1	0	1	1	1	1	1	0	Set V <sub>COMH</sub> Voltage	Set COM deselect voltage level [reset = 05h]																		
1	A[2:0]	0	0	0	0	0	A <sub>2</sub>	A <sub>1</sub>	A <sub>0</sub>																				
											<table border="1"> <thead> <tr> <th>A[2:0]</th> <th>Hex code</th> <th>V<sub>COMH</sub></th> </tr> </thead> <tbody> <tr> <td>000</td> <td>00h</td> <td>0.72 x V<sub>CC</sub></td> </tr> <tr> <td>:</td> <td>:</td> <td>:</td> </tr> <tr> <td>101</td> <td>05h</td> <td>0.82 x V<sub>CC</sub> [reset]</td> </tr> <tr> <td>:</td> <td>:</td> <td>:</td> </tr> <tr> <td>111</td> <td>07h</td> <td>0.86 x V<sub>CC</sub></td> </tr> </tbody> </table>	A[2:0]	Hex code	V <sub>COMH</sub>	000	00h	0.72 x V <sub>CC</sub>	:	:	:	101	05h	0.82 x V <sub>CC</sub> [reset]	:	:	:	111	07h	0.86 x V <sub>CC</sub>
A[2:0]	Hex code	V <sub>COMH</sub>																											
000	00h	0.72 x V <sub>CC</sub>																											
:	:	:																											
101	05h	0.82 x V <sub>CC</sub> [reset]																											
:	:	:																											
111	07h	0.86 x V <sub>CC</sub>																											
0	C1	1	1	0	0	0	0	0	1	Set Contrast Current for Color A,B,C	A[7:0] Contrast Value Color A [reset=7Fh] B[7:0] Contrast Value Color B [reset=7Fh] C[7:0] Contrast Value Color C [reset=7Fh]																		
1	A[7:0]	A <sub>7</sub>	A <sub>6</sub>	A <sub>5</sub>	A <sub>4</sub>	A <sub>3</sub>	A <sub>2</sub>	A <sub>1</sub>	A <sub>0</sub>																				
1	B[7:0]	B <sub>7</sub>	B <sub>6</sub>	B <sub>5</sub>	B <sub>4</sub>	B <sub>3</sub>	B <sub>2</sub>	B <sub>1</sub>	B <sub>0</sub>																				
1	C[7:0]	C <sub>7</sub>	C <sub>6</sub>	C <sub>5</sub>	C <sub>4</sub>	C <sub>3</sub>	C <sub>2</sub>	C <sub>1</sub>	C <sub>0</sub>																				
0	C7	1	1	0	0	0	1	1	1	Master Contrast Current Control	A[3:0] : 0000b reduce output currents for all colors to 1/16 0001b reduce output currents for all colors to 2/16 ..... 1110b reduce output currents for all colors to 15/16 1111b no change [reset]																		
1	A[3:0]	*	*	*	*	A <sub>3</sub>	A <sub>2</sub>	A <sub>1</sub>	A <sub>0</sub>																				
0	CA	1	1	0	0	1	0	1	0	Set MUX Ratio	A[6:0] MUX ratio 4MUX ~ 128MUX, [reset=127], (Range from 3 to 127)																		
1	A[6:0]	0	A <sub>6</sub>	A <sub>5</sub>	A <sub>4</sub>	A <sub>3</sub>	A <sub>2</sub>	A <sub>1</sub>	A <sub>0</sub>																				
0	E3	1	1	1	0	0	0	1	1	NOP	Command for No Operation																		

Fundamental Command Table											
D/C#	Hex	D7	D6	D5	D4	D3	D2	D1	D0	Command	Description
0	FD	1	1	1	1	1	1	0	1	Set Command Lock	A[7:0]: MCU protection status [reset = 12h] A[7:0] = 12h, Unlock OLED driver IC MCU interface from entering command [reset] A[7:0] = 16h, Lock OLED driver IC MCU interface from entering command
1	A[7:0]	A <sub>7</sub>	A <sub>6</sub>	A <sub>5</sub>	A <sub>4</sub>	A <sub>3</sub>	A <sub>2</sub>	A <sub>1</sub>	A <sub>0</sub>		<b>Note</b> <sup>(1)</sup> The locked OLED driver IC MCU interface prohibits all commands and memory access except the FDh command.

Graphic acceleration command											
D/C#	Hex	D7	D6	D5	D4	D3	D2	D1	D0	Command	Description
0	96	1	0	0	1	0	1	1	0	Horizontal Scroll	A[7:0] = 00000000b No scrolling A[7:0] = 00000001b to 00111111b Scroll towards SEG127 with 1 column offset
1	A[7:0]	A <sub>7</sub>	A <sub>6</sub>	A <sub>5</sub>	A <sub>4</sub>	A <sub>3</sub>	A <sub>2</sub>	A <sub>1</sub>	A <sub>0</sub>		A[7:0] = 01000000b to 11111111b Scroll towards SEG0 with 1 column offset
1	B[6:0]	0	B <sub>6</sub>	B <sub>5</sub>	B <sub>4</sub>	B <sub>3</sub>	B <sub>2</sub>	B <sub>1</sub>	B <sub>0</sub>		B[6:0] : start row address
1	C[7:0]	0	C <sub>6</sub>	C <sub>5</sub>	C <sub>4</sub>	C <sub>3</sub>	C <sub>2</sub>	C <sub>1</sub>	C <sub>0</sub>		C[7:0] : end row address
1	D[6:0]	0	D <sub>6</sub>	D <sub>5</sub>	D <sub>4</sub>	D <sub>3</sub>	D <sub>2</sub>	D <sub>1</sub>	D <sub>0</sub>		D[6:0] : Reserved (reset=00h)
1	E[1:0]	0	0	0	0	0	0	E <sub>1</sub>	E <sub>0</sub>		E[1:0] : scrolling time interval 00b Invalid 01b normal 10b slow 11b slowest
0	9E	1	0	0	1	1	1	1	0	Stop Moving	Stop horizontal scroll <b>Note</b> After sending 9Eh command to stop the scrolling action, the ram data needs to be rewritten
0	9F	1	0	0	1	1	1	1	1	Start Moving	Start horizontal scroll

# Timing Characteristics

## 4-wire SPI:

Symbol	Parameter	Min	Typ	Max	Unit
$t_{cycle}$	Clock Cycle Time	100	-	-	ns
$t_{AS}$	Address Setup Time	15	-	-	ns
$t_{AH}$	Address Hold Time	42	-	-	ns
$t_{CSS}$	Chip Select Setup Time	20	-	-	ns
$t_{CSH}$	Chip Select Hold Time	10	-	-	ns
$t_{DSW}$	Write Data Setup Time	15	-	-	ns
$t_{DHW}$	Write Data Hold Time	20	-	-	ns
$t_{CLKL}$	Clock Low Time	20	-	-	ns
$t_{CLKH}$	Clock High Time	20	-	-	ns
$t_R$	Rise Time	-	-	15	ns
$t_F$	Fall Time	-	-	15	ns

Figure 9-3 : Serial interface characteristics (4-wire SPI)

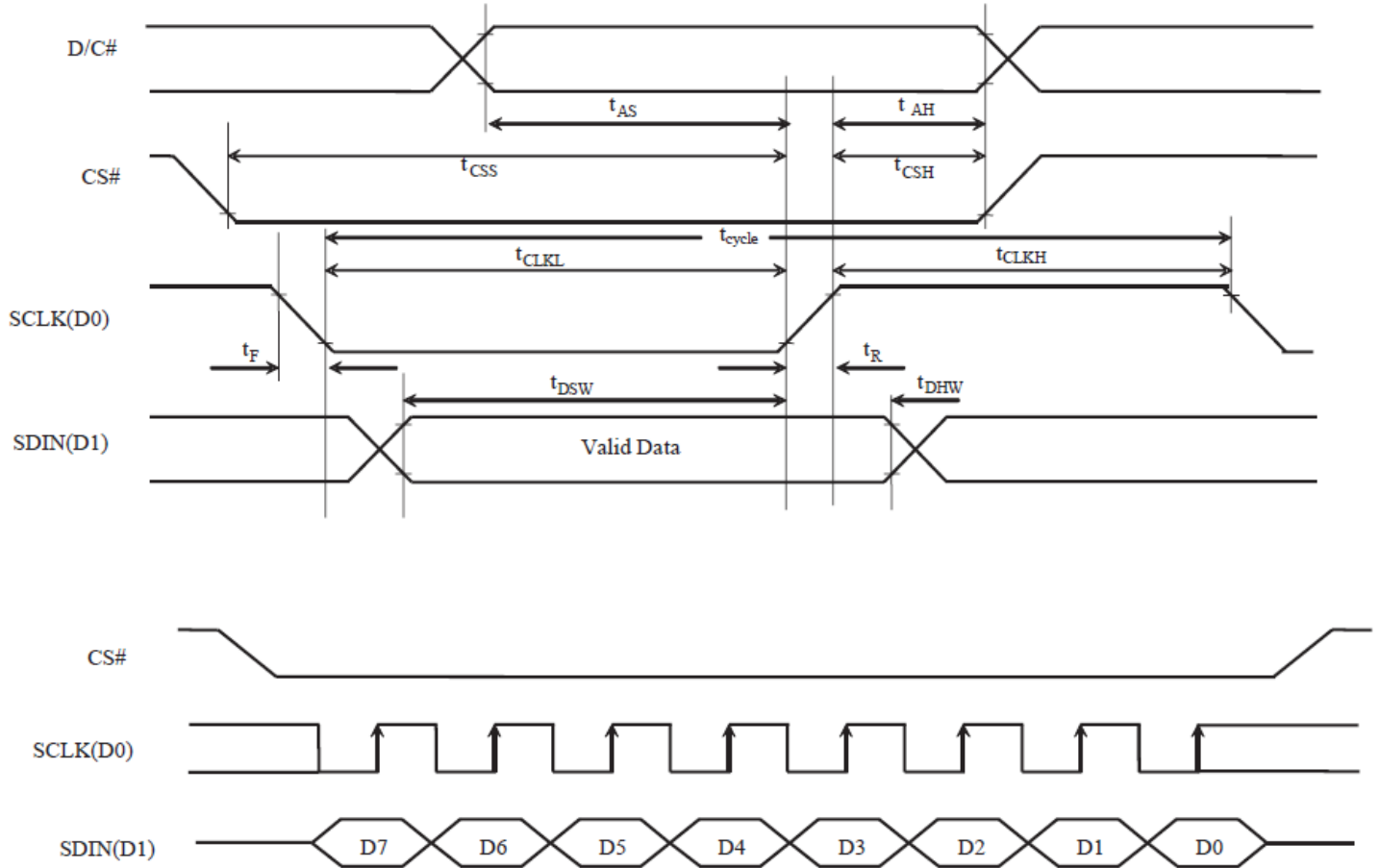

## Example Initialization Sequence:

```
void OLED_Init_6464RGB(void)
{
  GPIO_ResetBits(RES_pin);
  delay_ms(300);
  GPIO_SetBits(RES_pin);
  delay_ms(10);

  oled_Command_6464RGB(0xFD); //Command Unlock
  oled_Data_6464RGB(0x12);

  oled_Command_6464RGB(0xAE); //Set Display OFF

  oled_Command_6464RGB(0xB3); //Set Display Clock Divide Ratio/Oscillator Frequency
  oled_Data_6464RGB(0xB0);

  oled_Command_6464RGB(0xCA); //Set MUX Ratio
  oled_Data_6464RGB(0x3F);

  oled_Command_6464RGB(0xA2); //Set Display Offset
  oled_Data_6464RGB(0x40);

  oled_Command_6464RGB(0xA1); //Set Display Start Line
  oled_Data_6464RGB(0x00);

  oled_Command_6464RGB(0xA0); //Set Re-map & Color Depth
  oled_Data_6464RGB(0x70);
  oled_Data_6464RGB(0x00);

  oled_Command_6464RGB(0xC1); //Set Contrast Current
  oled_Data_6464RGB(0x88);
  oled_Data_6464RGB(0x32);
  oled_Data_6464RGB(0x88);

  oled_Command_6464RGB(0xC7); //Master Contrast Current Control
  oled_Data_6464RGB(0x0F);

  oled_Command_6464RGB(0xB1); //Set Phase Length
  oled_Data_6464RGB(0x32);

  oled_Command_6464RGB(0xB6); //Set Second Pre-charge Period
  oled_Data_6464RGB(0x01);

  oled_Command_6464RGB(0xB8); //Gamma Look-up Table
  oled_Data_6464RGB(0x02);
  oled_Data_6464RGB(0x03);
  oled_Data_6464RGB(0x04);
  oled_Data_6464RGB(0x05);
  oled_Data_6464RGB(0x06);
  oled_Data_6464RGB(0x07);
  oled_Data_6464RGB(0x08);
  oled_Data_6464RGB(0x09);
  oled_Data_6464RGB(0x0A);
  oled_Data_6464RGB(0x0B);
```

oled\_Data\_6464RGB(0x0C);  
oled\_Data\_6464RGB(0x0D);  
oled\_Data\_6464RGB(0x0E);  
oled\_Data\_6464RGB(0x0F);  
oled\_Data\_6464RGB(0x10);  
oled\_Data\_6464RGB(0x11);  
oled\_Data\_6464RGB(0x12);  
oled\_Data\_6464RGB(0x13);  
oled\_Data\_6464RGB(0x15);  
oled\_Data\_6464RGB(0x17);  
oled\_Data\_6464RGB(0x19);  
oled\_Data\_6464RGB(0x1B);  
oled\_Data\_6464RGB(0x1D);  
oled\_Data\_6464RGB(0x1F);  
oled\_Data\_6464RGB(0x21);  
oled\_Data\_6464RGB(0x23);  
oled\_Data\_6464RGB(0x25);  
oled\_Data\_6464RGB(0x27);  
oled\_Data\_6464RGB(0x2A);  
oled\_Data\_6464RGB(0x2D);  
oled\_Data\_6464RGB(0x30);  
oled\_Data\_6464RGB(0x33);  
oled\_Data\_6464RGB(0x36);  
oled\_Data\_6464RGB(0x39);  
oled\_Data\_6464RGB(0x3C);  
oled\_Data\_6464RGB(0x3F);  
oled\_Data\_6464RGB(0x42);  
oled\_Data\_6464RGB(0x45);  
oled\_Data\_6464RGB(0x48);  
oled\_Data\_6464RGB(0x4C);  
oled\_Data\_6464RGB(0x50);  
oled\_Data\_6464RGB(0x54);  
oled\_Data\_6464RGB(0x58);  
oled\_Data\_6464RGB(0x5C);  
oled\_Data\_6464RGB(0x60);  
oled\_Data\_6464RGB(0x64);  
oled\_Data\_6464RGB(0x68);  
oled\_Data\_6464RGB(0x6C);  
oled\_Data\_6464RGB(0x70);  
oled\_Data\_6464RGB(0x74);  
oled\_Data\_6464RGB(0x78);  
oled\_Data\_6464RGB(0x7D);  
oled\_Data\_6464RGB(0x82);  
oled\_Data\_6464RGB(0x87);  
oled\_Data\_6464RGB(0x8C);  
oled\_Data\_6464RGB(0x91);  
oled\_Data\_6464RGB(0x96);  
oled\_Data\_6464RGB(0x9B);  
oled\_Data\_6464RGB(0xA0);  
oled\_Data\_6464RGB(0xA5);  
oled\_Data\_6464RGB(0xAA);  
oled\_Data\_6464RGB(0xAF);  
oled\_Data\_6464RGB(0xB4);

```
oled_Command_6464RGB(0xBB); //Set Pre-charge Voltage
oled_Data_6464RGB(0x17);

oled_Command_6464RGB(0xBE); //Set VCOMH
oled_Data_6464RGB(0x05);

oled_Command_6464RGB(0x15); //Set Column Address
oled_Data_6464RGB(0x20);
oled_Data_6464RGB(0x5F);

oled_Command_6464RGB(0x75); //Set Row Address
oled_Data_6464RGB(0x00);
oled_Data_6464RGB(0x3F);

oled_Command_6464RGB(0xA6); //Set Display Mode

oled_Clear_Screen();           //Clear Display (write all 0x00's to display RAM)

oled_Command_6464RGB(0xAF); //Set Display ON

oled_Command_6464RGB(0x5C); //Enable Write Data into RAM
}
```

## Quality Information

Test Item	Content of Test	Test Condition	Note
High Temperature storage	Test the endurance of the display at high storage temperature.	+85°C, 240 Hrs.	2
Low Temperature storage	Test the endurance of the display at low storage temperature.	-40°C, 240 Hrs.	1,2
High Temperature Operation	Test the endurance of the display by applying electric stress (voltage & current) at high temperature.	+70°C, 240 Hrs.	2
Low Temperature Operation	Test the endurance of the display by applying electric stress (voltage & current) at low temperature.	-40°C, 240 Hrs.	1,2
High Temperature / Humidity Operation	Test the endurance of the display by applying electric stress (voltage & current) at high temperature with high humidity.	+60°C, 90% RH, 120 Hrs.	1,2
Thermal Shock resistance	Test the endurance of the display by applying electric stress (voltage & current) during a cycle of low and high temperatures.	-40°C, 30 min -> 25°C, 5 min -> 70°C, 30 min = 1 cycle 100 Cycles	
Vibration test	Test the endurance of the display by applying vibration to simulate transportation and use.	10-22Hz , 15mm amplitude. 22-500Hz, 1.5G 30min in each of 3 directions X,Y,Z	3
Atmospheric Pressure test	Test the endurance of the display by applying atmospheric pressure to simulate transportation by air.	115mbar, 40hrs	3
Static electricity test	Test the endurance of the display by applying electric static discharge.	V <sub>s</sub> =800V, R <sub>s</sub> =1.5kΩ, C <sub>s</sub> =100pF One time	

**Note 1:** No condensation to be observed.

**Note 2:** Conducted after 2 hours of storage at 25°C, 0%RH.

**Note 3:** Test performed on product itself, not inside a container.

### Evaluation Criteria:

- 1: Display is fully functional during operational tests and after all tests, at room temperature.
- 2: No observable defects.
- 3: Luminance >50% of initial value.
- 4: Current consumption within 50% of initial value

## Precautions for using OLEDs/LCDs/LCMs

See Precautions at [www.newhavendisplay.com/specs/precautions.pdf](http://www.newhavendisplay.com/specs/precautions.pdf)

## Warranty Information

See Terms & Conditions at [http://www.newhavendisplay.com/index.php?main\\_page=terms](http://www.newhavendisplay.com/index.php?main_page=terms)