

FEATURES

- SMALLER THAN NEXA SERIES
- DOUBLE LAYER CONSTRUCTION
- SHORT TERM POWER SOURCE (UP TO 50mA)
- SUITABLE FOR FLOW SOLDERING
- LEAD-FREE FINISH

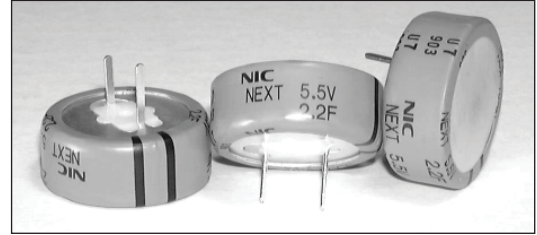

CHARACTERISTICS

Rated Voltage Range	5.5VDC	
Rated Capacitance Range	0.1F ~ 5.6F (100,000μF ~ 5,600,000μF)	
Operating Temp. Range	-40°C ~ +85°C	
Capacitance Tolerance	+80%/-20% (Z)	
Load Life Test @ 85°C 1,000 hours	Δ Capacitance Change	Less than ±30% of initial measured value
	Maximum ESR	Less than 200% of the specified maximum value
	Current at 30 minutes	Less than 200% of the specified maximum value
Temperature Cycling (5 cycles, -40 ~ +85°C)	Δ Capacitance Change	Within +80%/-20% of specified value
	Maximum ESR	Less than specified maximum value
	Current at 30 minutes	Less than specified maximum value
Humidity Resistance (240 hours @ 40°C/90% RH)	Δ Capacitance Change	Less than ±20% of initial measured value
	Maximum ESR	Less than 120% of the specified maximum value
	Current at 30 minutes	Less than 120% of the specified maximum value

Super Capacitor Application Guide

STANDARD VALUES AND SPECIFICATIONS

NIC P/N	Capacitance Value (F)		Rated Voltage (VDC)	Max. Current @ 30 minutes (mA)	Max. ESR @ 1KHz (Ω)	Typical DCR (Ω)
	Charge	Discharge				
NEXT104Z5.5V11.5X8.5F	0.10	0.14	5.5	< 0.15	< 16	23
NEXT224Z5.5V14.5X12F	0.22	0.28	5.5	< 0.33	< 10	16
NEXT474Z5.5V16.5X13F	0.47	0.60	5.5	< 0.71	< 6.5	5.4
NEXT105Z5.5V21.5X13F	1.0	1.3	5.5	< 1.5	< 3.5	2.9
NEXT225Z5.5V28.5X14F	2.2	2.8	5.5	< 3.3	< 1.8	2.1
NEXT335Z5.5V36.5X15F	3.3	4.2	5.5	< 5.0	< 1.0	1.3
NEXT565Z5.5V44.5X17F	5.6	7.2	5.5	< 8.4	< 0.6	0.8

CASE DIMENSIONS (mm)

NIC P/N	DIMENSIONS (mm)					
	D	H	S	LL	d1	d2
NEXT104Z5.5V11.5X8.5F	11.5	8.5	5.08	2.7	0.4	1.2
NEXT224Z5.5V14.5X12F	14.5	12.0	5.08	2.2	0.4	1.2
NEXT474Z5.5V16.5X13F	16.5	13.0	5.08	2.7	0.4	1.2
NEXT105Z5.5V21.5X13F	21.5	13.0	7.62	3.0	0.6	1.2
NEXT225Z5.5V28.5X14F	28.5	14.0	10.16	6.1	0.6	1.4
NEXT335Z5.5V36.5X15F	36.5	15.0	15.0	6.1	0.6	1.7
NEXT565Z5.5V44.5X17F	44.5	17.0	20.0	6.1	1.0	1.4

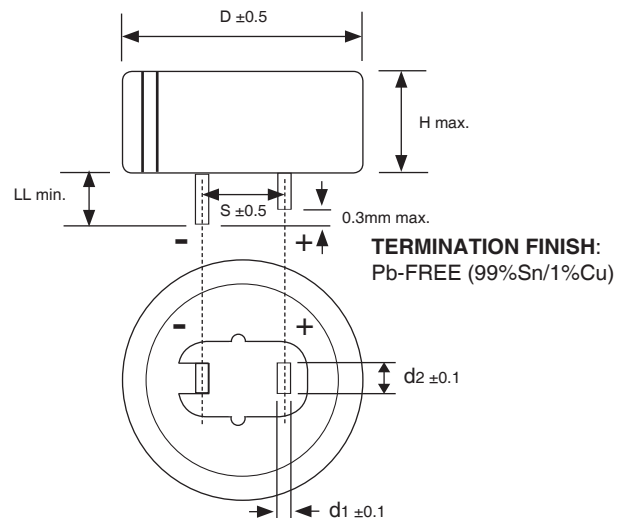

PRECAUTIONS

WASHING is NOT RECOMMENDED. Additional guidelines and precautions can be found at www.nicomp.com/precautions
 If in doubt or uncertainty, please review your specific application - process details with NIC's technical support personnel: tpmg@nicomp.com

