

# NCV4949C

## Voltage Regulator - Low Dropout, Reset, Sense

100 mA, 5.0 V

The NCV4949C is a monolithic integrated 5.0 V voltage regulator with a very low dropout and additional functions such as reset and an uncommitted voltage sense comparator.

It is designed for supplying microcontroller/microprocessor controlled systems particularly in automotive applications. The NCV4949C has improved reset behavior for lower input and output voltage levels.

### Features

- Operating DC Supply Voltage Range 5.5 V to 40 V
- High Precision Output Voltage 5.0 V  $\pm 1\%$
- Output Current Capability Up to 100 mA
- Very Low Dropout Voltage Less Than 0.4 V
- Reset Circuit Sensing The Output Voltage
- Programmable Reset Pulse Delay
- Voltage Sense Comparator
- Fault Protection, +60 V Peak Transient Voltage, -40 V Reverse Voltage, Short Circuit, Thermal Overload
- NCV Prefix for Automotive and Other Applications Requiring Site and Change Control
- These are Pb-Free Devices

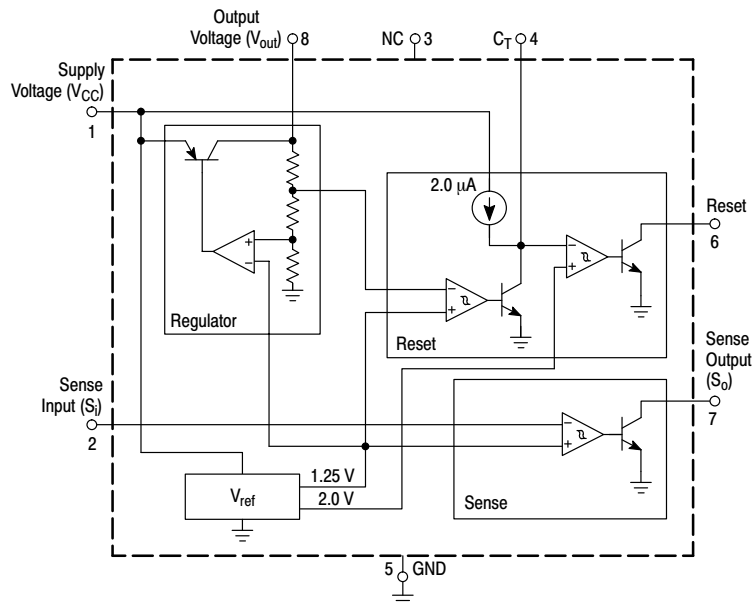

Figure 1. Representative Block Diagram



ON Semiconductor®

[www.onsemi.com](http://www.onsemi.com)

### MARKING DIAGRAMS



SOIC-8  
D SUFFIX  
CASE 751-07

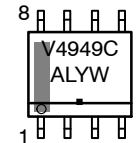

SOIC-8 EP  
PD SUFFIX  
CASE 751AC

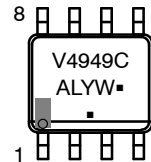

- A = Assembly Location
- L = Wafer Lot
- Y = Year
- W = Work Week
- = Pb-Free Device

(Note: Microdot may be in either location)

### PIN CONNECTIONS

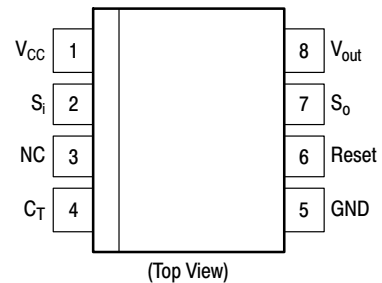

### ORDERING INFORMATION

See detailed ordering and shipping information in the package dimensions section on page 8 of this data sheet.

# NCV4949C

## PIN FUNCTION DESCRIPTION

SO-8 Pin#	SO-8 EP	Symbol	Description
1	1	$V_{CC}$	Supply Voltage
2	2	$S_i$	Input of Sense Comparator
4	4	$C_T$	Reset Delay Capacitor
5	5	GND	Ground
6	6	Reset	Output of Reset Comparator
7	7	$S_o$	Output of Sense Comparator
8	8	$V_{out}$	Main Regulator Output
3	3	NC	No Connect
-	EPAD	EPAD	Connect to Ground potential or leave unconnected

## MAXIMUM RATINGS

Rating	Symbol	Min	Max	Unit
DC Operating Supply Voltage	$V_{CC}$	5.5	40	V
Input to Regulator	$V_{CC}$	-40	45	V
Transient Supply Voltage (Note 1)	$V_{CC TR}$	-	60	V
Output	$V_{out}$ $I_{out}$	-0.5 -10	20 Internally Limited	V mA
Sense Input	$V_{SI}$ $I_{SI}$	-40 -1.0	45 1.0	V mA
Sense Output	$V_{SO}$ $I_{SO}$	-0.3 -5.0	7.0 5.0	V mA
Reset Output	$V_{Reset}$ $I_{Reset}$	-0.3 -5.0	7.0 5.0	V mA
Reset Delay	$V_{CT}$ $I_{CT}$	-0.3 Internally Limited	7.0 Internally Limited	V mA
ESD Protection at any pin	Human Body Model	-	4000	V
	Machine Model	-	400	
Operating Junction Temperature Range	$T_J$	-40	+150	°C
Storage Temperature Range	$T_{STG}$	-50	+150	°C

Stresses exceeding those listed in the Maximum Ratings table may damage the device. If any of these limits are exceeded, device functionality should not be assumed, damage may occur and reliability may be affected.

1. Load Dump Test B (with centralized load dump suppression) according to ISO16750-2 standard. Guaranteed by design. Not tested in production. Passed Class C according to ISO16750-1.

## THERMAL CHARACTERISTICS

Characteristic	Test Conditions (Typical Values)			Unit
	Note 2	Note 3	Note 4	
SOIC-8 Junction-to-Lead ( $\Psi_{JLx6}$ , $\theta_{JL6}$ ) Junction-to-Ambient ( $R_{\theta JA}$ , $\theta_{JA}$ )	65.6	62	61	°C/W
	169.4	147.6	127.2	
SOIC-8 EP Junction-to-Lead ( $\Psi_{JL6}$ , $\theta_{JL6}$ ) Junction-to-Ambient ( $R_{\theta JA}$ , $\theta_{JA}$ )	36.1	32.1	27.4	°C/W
	109.2	91.1	71.9	

2. 1 oz. Copper, 100 mm sq. Copper area, 1.5 mm thick FR-4.

3. 1 oz. Copper, 200 mm sq. Copper area, 1.5 mm thick FR-4.

4. 1 oz. Copper, 500 mm sq. Copper area, 1.5 mm thick FR-4.

## LEAD TEMPERATURE SOLDERING REFLOW (Note 5)

Rating	Symbol	Min	Max	Unit
Reflow (SMD styles only) lead free 60 – 150 sec above 217, 40 sec max at peak	Tsld	-	260	°C
Moisture Sensitivity Level (SOIC-8)	MSL	Level 1		
Moisture Sensitivity Level (SOIC-8EP)	MSL	Level 2		

5. Per IPC / JEDEC J-STD-020C.

# NCV4949C

## ELECTRICAL CHARACTERISTICS ( $V_{CC} = 14\text{ V}$ , $-40^{\circ}\text{C} < T_J < 150^{\circ}\text{C}$ , unless otherwise specified.)

Characteristic	Symbol	Min	Typ	Max	Unit
Output Voltage ( $T_J = 25^{\circ}\text{C}$ , $I_{out} = 1.0\text{ mA}$ )	$V_{out}$	4.95	5.0	5.05	V
Output Voltage ( $6.0\text{ V} < V_{CC} < 28\text{ V}$ , $1.0\text{ mA} < I_{out} < 50\text{ mA}$ )	$V_{out}$	4.9	5.0	5.1	V
Output Voltage ( $V_{CC} = 35\text{ V}$ , $t < 1.0\text{ s}$ , $1.0\text{ mA} < I_{out} < 50\text{ mA}$ )	$V_{out}$	4.9	5.0	5.1	V
Dropout Voltage $I_{out} = 10\text{ mA}$ $I_{out} = 50\text{ mA}$ $I_{out} = 100\text{ mA}$	$V_{drop}$	-	0.08 0.18 0.22	0.25 0.40 0.50	V
Input to Output Voltage Difference in Undervoltage Condition ( $V_{CC} = 4.0\text{ V}$ , $I_{out} = 35\text{ mA}$ )	$V_{IO}$	-	0.12	0.4	V
Line Regulation ( $6.0\text{ V} < V_{CC} < 28\text{ V}$ , $I_{out} = 1.0\text{ mA}$ )	$Reg_{line}$	-	1.0	20	mV
Load Regulation ( $1.0\text{ mA} < I_{out} < 100\text{ mA}$ )	$Reg_{load}$	-	1.0	30	mV
Current Limit $V_{out} = 4.5\text{ V}$ $V_{out} = 0\text{ V}$	$I_{Lim}$	105 -	320 220	400 -	mA
Quiescent Current ( $I_{out} = 0.3\text{ mA}$ , $T_J < 100^{\circ}\text{C}$ )	$I_{QSE}$	-	120	260	$\mu\text{A}$
Quiescent Current ( $I_{out} = 100\text{ mA}$ )	$I_Q$	-	-	5.0	mA

## RESET

Reset Threshold Voltage	$V_{ResTh}$	-	4.5	-	V
Reset Threshold Hysteresis @ $T_J = 25^{\circ}\text{C}$ @ $T_J = -40\text{ to }+125^{\circ}\text{C}$	$V_{ResTh,hys}$	50 50	100 -	200 300	mV
Reset Pulse Delay ( $C_T = 100\text{ nF}$ , $t_R \geq 100\text{ }\mu\text{s}$ )	$t_{ResD}$	55	100	180	ms
Reset Reaction Time ( $C_T = 100\text{ nF}$ )	$t_{ResR}$	-	5.0	30	$\mu\text{s}$
Reset Output Low Voltage ( $R_{Reset} = 10\text{ k}\Omega$ to $V_{out}$ , $V_{CC} \geq 3.0\text{ V}$ )	$V_{ResL}$	-	-	0.3	V
Reset Output High Leakage Current ( $V_{Reset} = 5.0\text{ V}$ )	$I_{ResH}$	-	-	1.0	$\mu\text{A}$
Delay Comparator Threshold	$V_{CTTh}$	-	2.0	-	V
Delay Comparator Threshold Hysteresis	$V_{CTTh,hys}$	-	100	-	mV

## SENSE

Sense Low Threshold ( $V_{SI}$ Decreasing = $1.5\text{ V}$ to $1.0\text{ V}$ )	$V_{SOth}$	1.16	1.25	1.35	V
Sense Threshold Hysteresis	$V_{SOth,hys}$	20	100	200	mV
Sense Output Low Voltage ( $V_{SI} \leq 1.16\text{ V}$ , $V_{CC} \geq 3.0\text{ V}$ , $R_{SO} = 10\text{ k}\Omega$ to $V_{out}$ )	$V_{SOL}$	-	-	0.4	V
Sense Output Leakage ( $V_{SO} = 5.0\text{ V}$ , $V_{SI} \geq 1.5\text{ V}$ )	$I_{SOH}$	-	-	1.0	$\mu\text{A}$
Sense Input Current	$I_{SI}$	-1.0	0.1	1.0	$\mu\text{A}$

## THERMAL SHUTDOWN

Thermal Shutdown Temperature ( $I_{out} = 1\text{ mA}$ ) (Note 6)	$T_{SD}$	150	-	200	$^{\circ}\text{C}$
---	----------	-----	---	-----	--------------------

Product parametric performance is indicated in the Electrical Characteristics for the listed test conditions, unless otherwise noted. Product performance may not be indicated by the Electrical Characteristics if operated under different conditions.

6. Values based on design and/or characterization.

TYPICAL CHARACTERISTICS

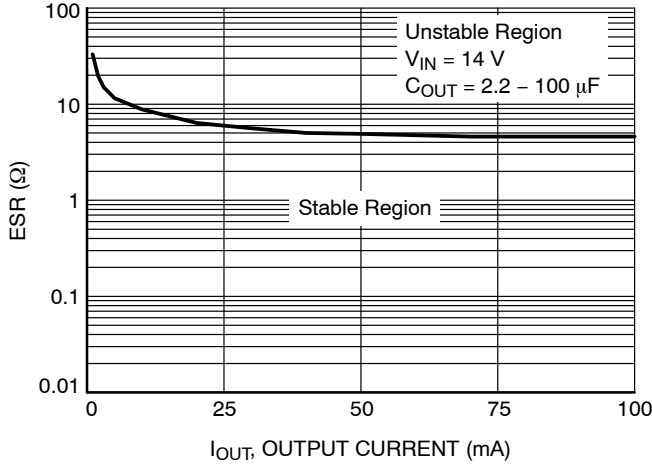

Figure 2. ESR Stability Border vs. Output Current

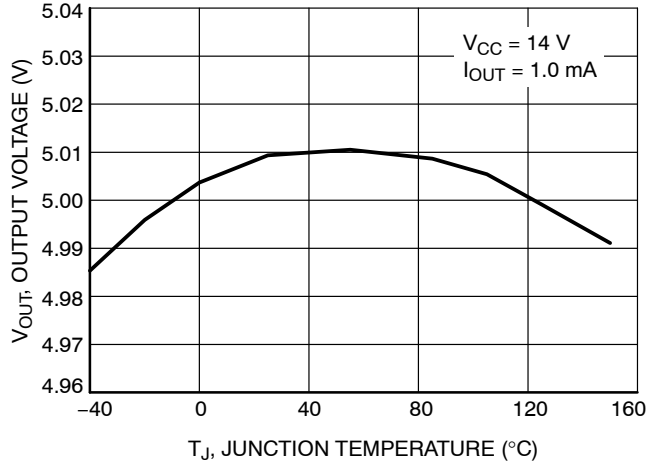

Figure 3. Output Voltage vs. Junction Temperature

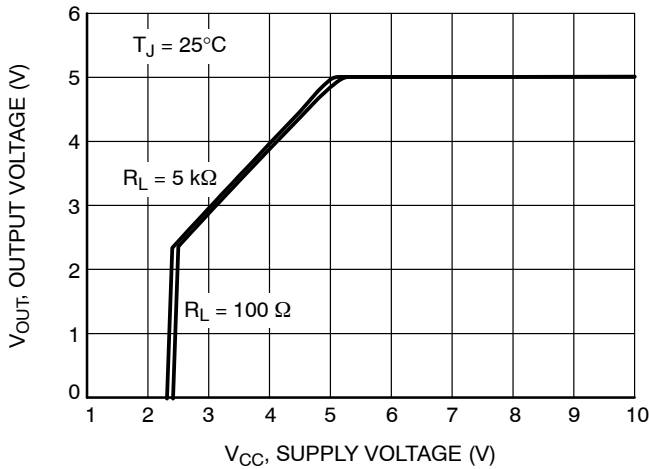

Figure 4. Output Voltage vs. Supply Voltage

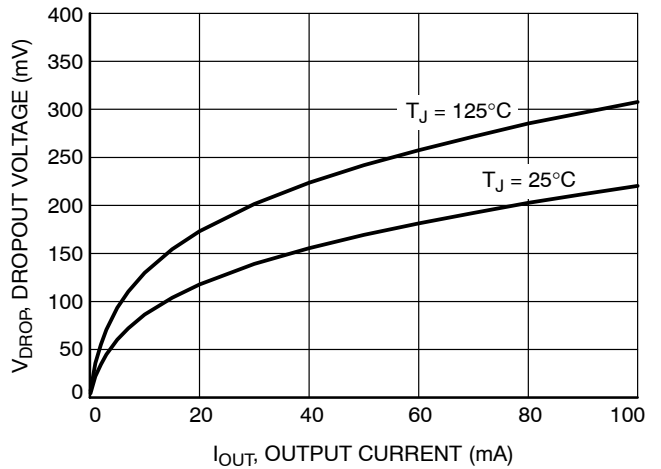

Figure 5. Dropout Voltage vs. Output Current

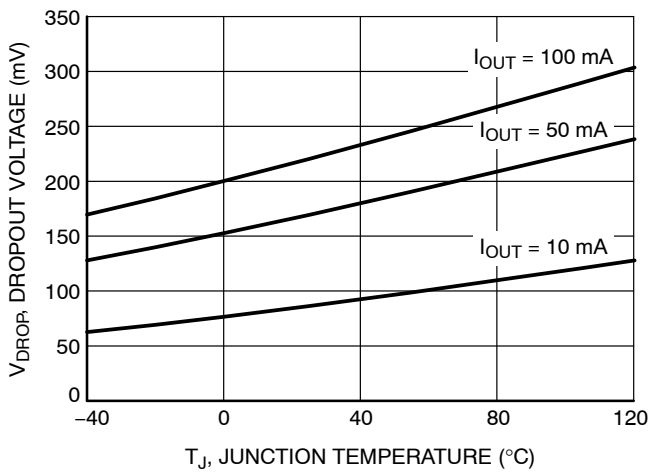

Figure 6. Dropout Voltage vs. Junction Temperature

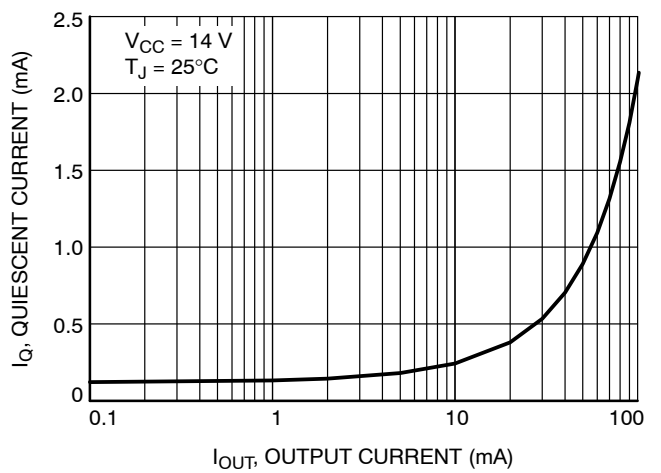

Figure 7. Quiescent Current vs. Output Current

TYPICAL CHARACTERISTICS

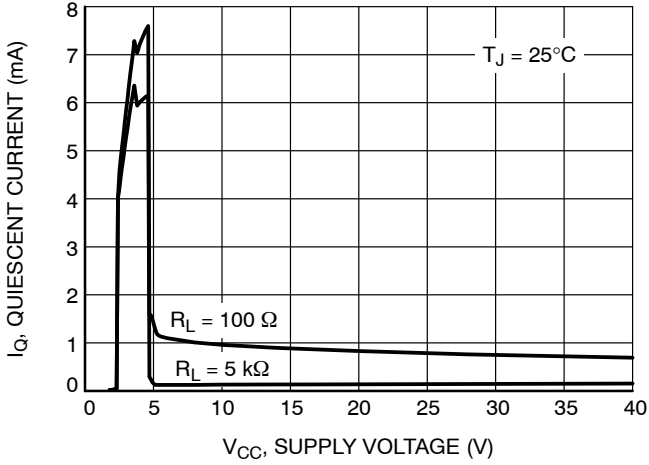

Figure 8. Quiescent Current vs. Supply Voltage

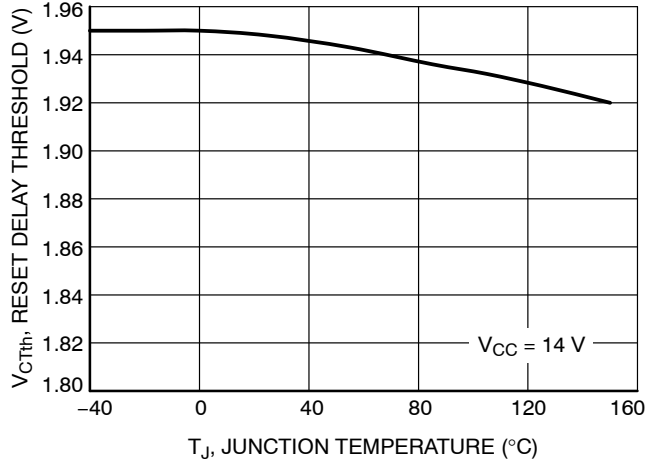

Figure 9. Reset Delay Threshold vs. Junction Temperature

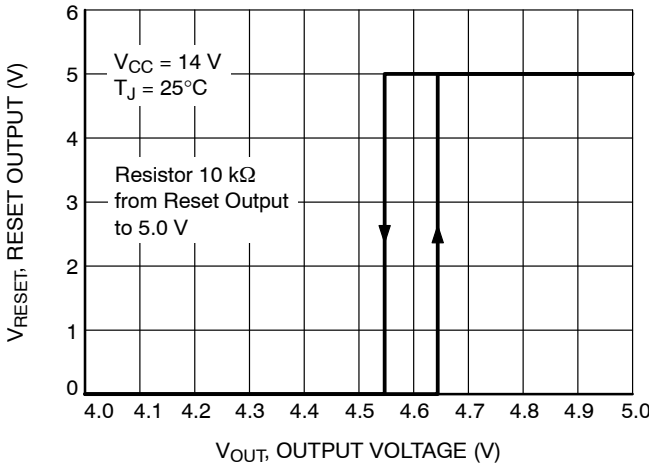

Figure 10. Reset Output vs. Regulator Output Voltage

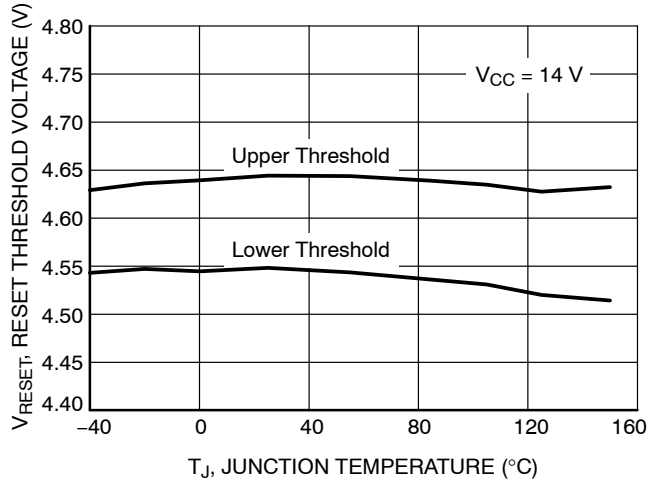

Figure 11. Reset Thresholds vs. Junction Temperature

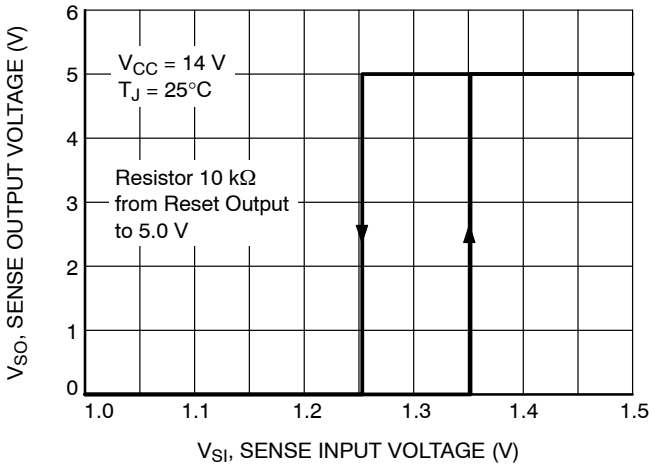

Figure 12. Sense Output vs. Sense Input Voltage

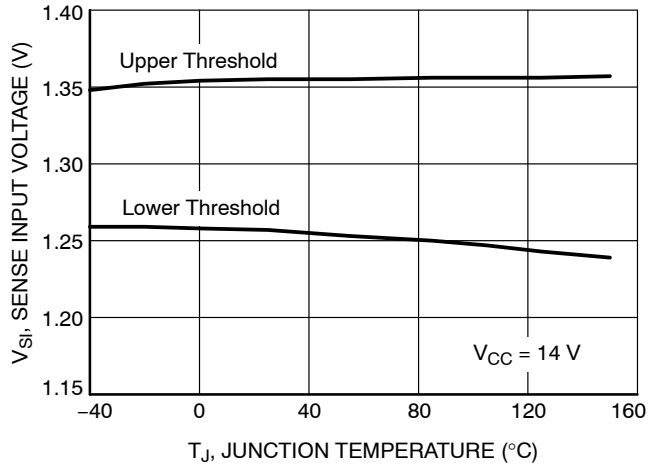
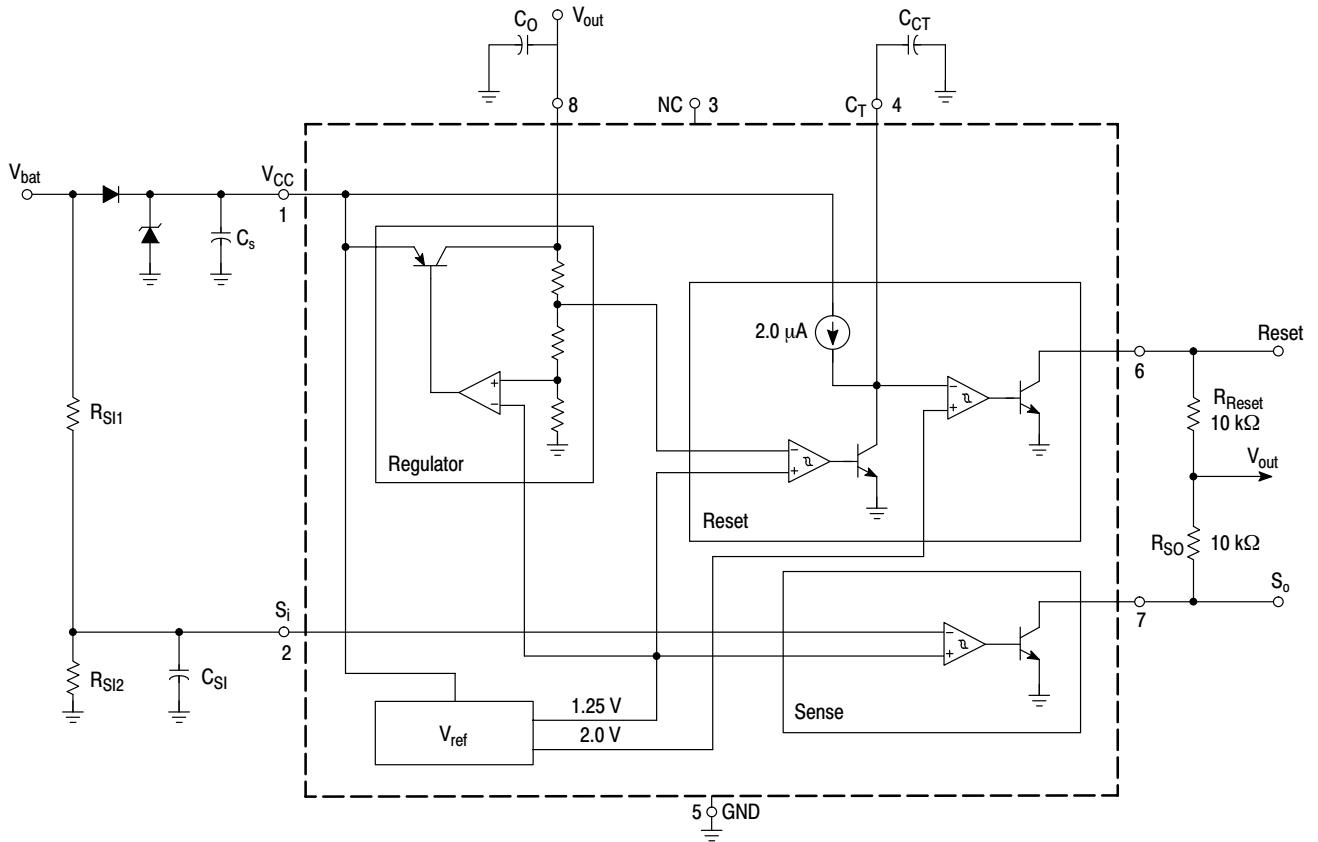

Figure 13. Sense Thresholds vs. Junction Temperature

# NCV4949C

## APPLICATION INFORMATION



NOTE: 1. For good dynamic performance:  $C_s \geq 1.0 \mu\text{F}$ ,  $C_o \geq 4.7 \mu\text{F}$ ,  $\text{ESR} < 4.5 \Omega$  at 10 kHz

**Figure 14. Application Schematic**

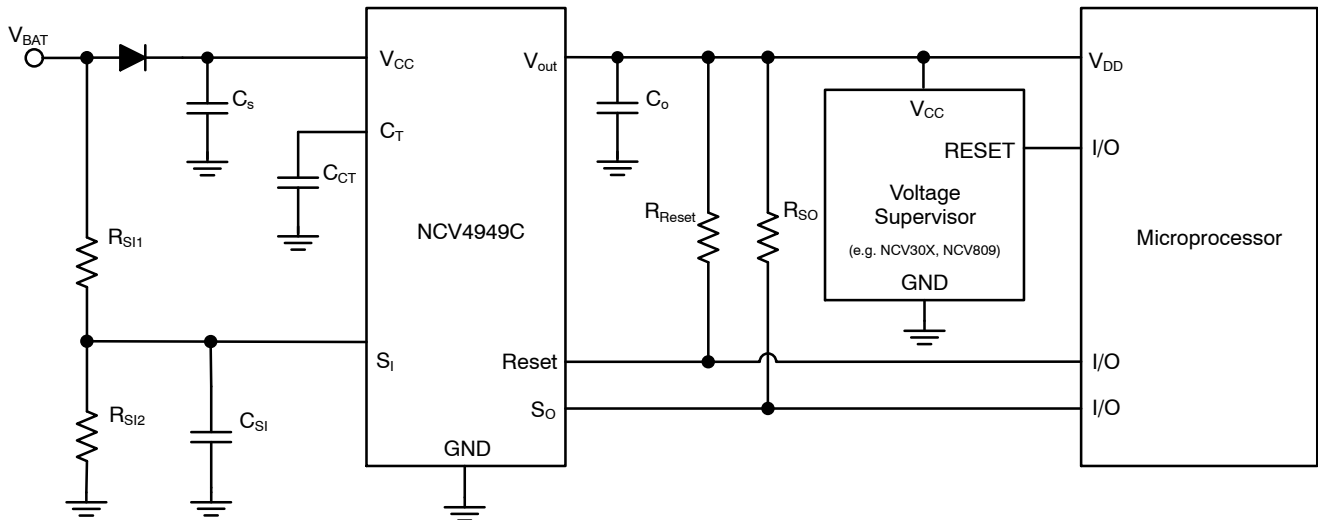

NOTE: The NCV4949C is not developed in compliance with ISO26262 standard. If application is safety critical then the above application diagram shown in Figure 15 can be used.

**Figure 15. Application Diagram**

OPERATING DESCRIPTION

The NCV4949C is a monolithic integrated low dropout voltage regulator. Several outstanding features and auxiliary functions are implemented to meet the requirements of supplying microprocessor systems in automotive applications. It is also suitable in other applications where the included functions are required. The modular approach of this device allows the use of other features and functions independently when required.

**Voltage Regulator**

The voltage regulator uses a lateral PNP transistor as a regulating element. With this structure, very low dropout voltage at currents up to 100 mA is obtained. The dropout operation of the standby regulator is maintained typically down to 2.5 V input supply voltage.

A typical curve showing the standby output voltage as a function of the input supply voltage is shown in Figure 17.

The current consumption of the device (quiescent current) is less than 200  $\mu$ A.

To reduce the quiescent current peak in the undervoltage region and to improve the transient response in this region, the dropout voltage is controlled. The quiescent current as a function of the supply input voltage is shown in Figure 18.

*Short Circuit Protection:*

The maximum output current is internally limited. In case of short circuit, the output current is foldback current limited as described in Figure 16.

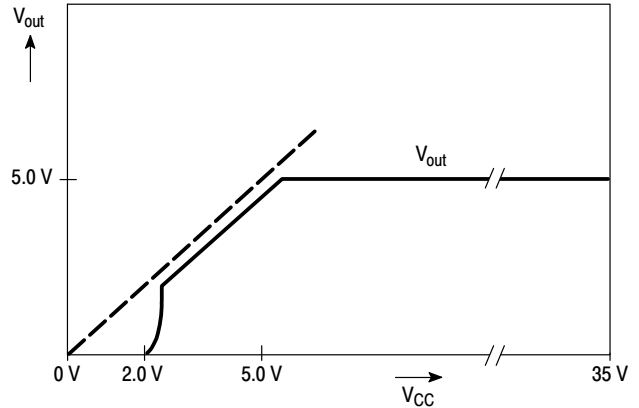

Figure 17. Output Voltage vs. Supply Voltage

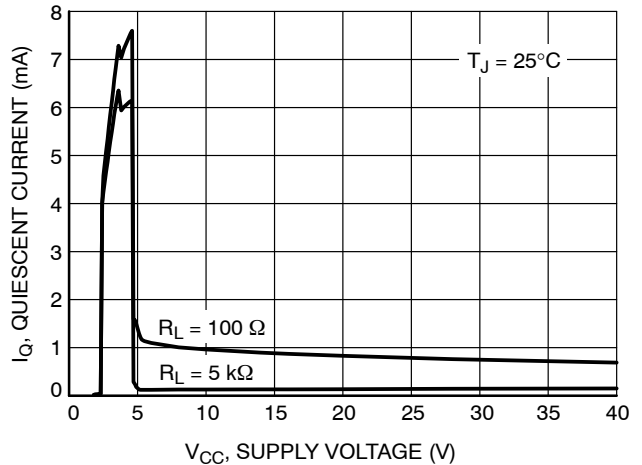

Figure 18. Quiescent Current vs. Supply Voltage

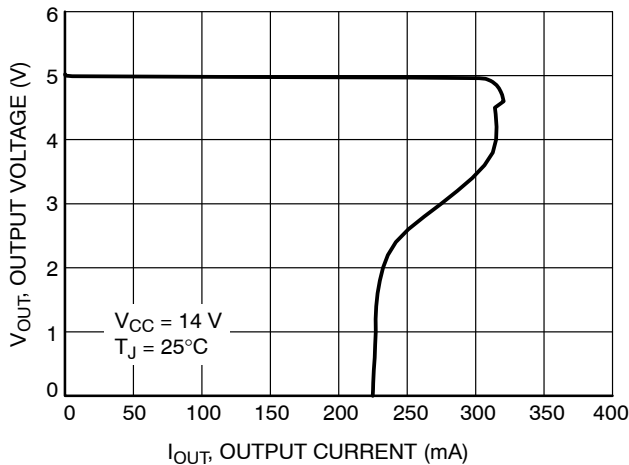

Figure 16. Foldback Characteristic of  $V_{out}$

**Reset Circuit**

The block circuit diagram of the reset circuit is shown in Figure 19.

The reset circuit supervises the output voltage. The reset threshold of 4.5 V is defined by the internal reference voltage and standby output divider.

The reset pulse delay time  $t_{RD}$ , is defined by the charge time of an external capacitor  $C_T$ :

$$t_{RD} = \frac{C_T \times 2.0 \text{ V}}{2.0 \mu\text{A}}$$

The reaction time of the reset circuit originates from the discharge time limitation of the reset capacitor  $C_T$  and is proportional to the value of  $C_T$ . The reaction time of the reset circuit increases the noise immunity.

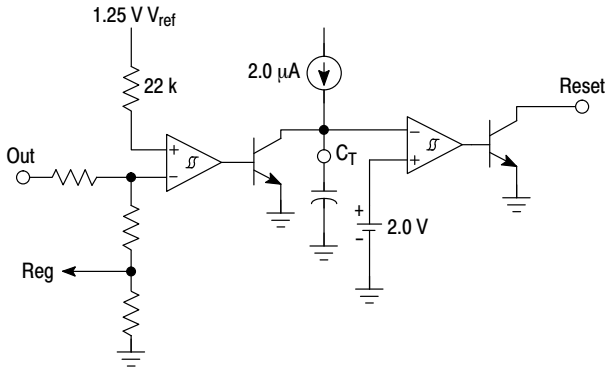

**Figure 19. Reset Circuit**

Output voltage drops below the reset threshold only marginally longer than the reaction time results in a shorter reset delay time.

The nominal reset delay time will be generated for output voltage drops longer than approximately 50 μs. The typical reset output waveforms are shown in Figure 20.

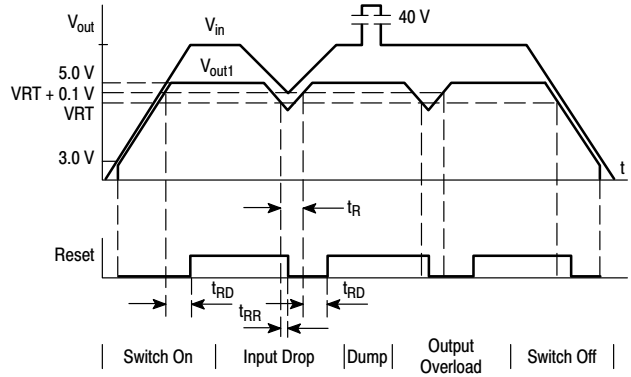

**Figure 20. Typical Reset Output Waveforms**

**Sense Comparator**

The sense comparator compares an input signal with an internal voltage reference of typical 1.25 V. The use of an external voltage divider makes this comparator very flexible in the application.

It can be used to supervise the input voltage either before or after a protection diode and to provide additional information to the microprocessor such as low voltage warnings.

**ORDERING INFORMATION**

Device	Package	Shipping <sup>†</sup>
NCV4949CDR2G	SOIC-8 (Pb-Free)	2500 / Tape & Reel
NCV4949CPDR2G	SOIC-8 EP (Pb-Free)	2500 / Tape & Reel

<sup>†</sup>For information on tape and reel specifications, including part orientation and tape sizes, please refer to our Tape and Reel Packaging Specifications Brochure, BRD8011/D.

# NCV4949C

## PACKAGE DIMENSIONS

### SOIC-8 EP CASE 751AC ISSUE B

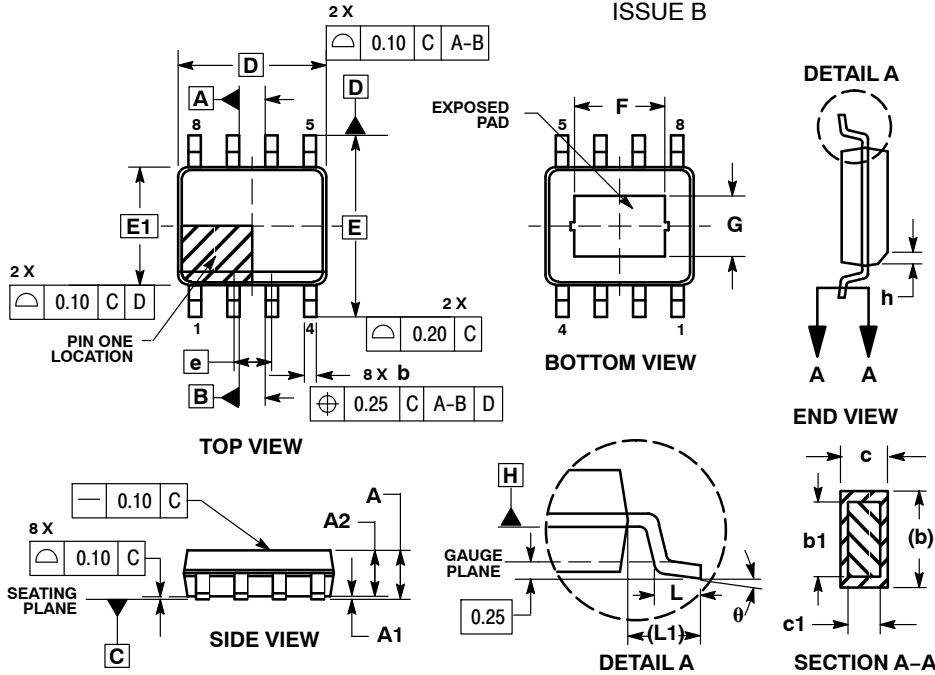

#### NOTES:

1. DIMENSIONS AND TOLERANCING PER ASME Y14.5M, 1994.
2. DIMENSIONS IN MILLIMETERS (ANGLES IN DEGREES).
3. DIMENSION b DOES NOT INCLUDE DAMBAR PROTRUSION. ALLOWABLE DAMBAR PROTRUSION SHALL BE 0.08 MM TOTAL IN EXCESS OF THE "b" DIMENSION AT MAXIMUM MATERIAL CONDITION.
4. DATUMS A AND B TO BE DETERMINED AT DATUM PLANE H.

MILLIMETERS		
DIM	MIN	MAX
A	1.35	1.75
A1	0.00	0.10
A2	1.35	1.65
b	0.31	0.51
b1	0.28	0.48
c	0.17	0.25
c1	0.17	0.23
D	4.90 BSC	
E	6.00 BSC	
E1	3.90 BSC	
e	1.27 BSC	
L	0.40	1.27
L1	1.04 REF	
F	2.24	3.20
G	1.55	2.51
h	0.25	0.50
θ	0°	8°

#### SOLDERING FOOTPRINT\*

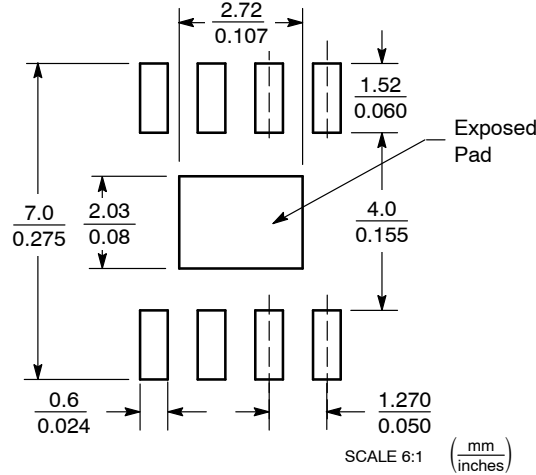

\*For additional information on our Pb-Free strategy and soldering details, please download the ON Semiconductor Soldering and Mounting Techniques Reference Manual, SOLDERRM/D.

# NCV4949C

## PACKAGE DIMENSIONS

### SOIC-8 NB CASE 751-07 ISSUE AK

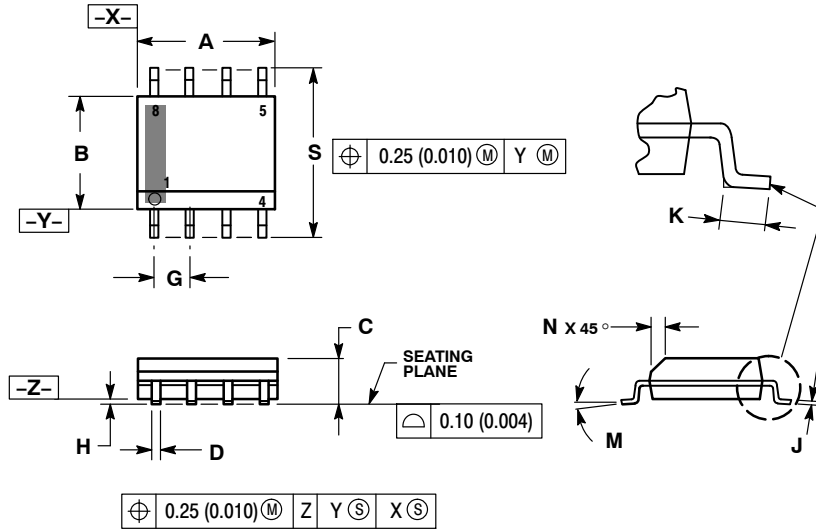

#### NOTES:

1. DIMENSIONING AND TOLERANCING PER ANSI Y14.5M, 1982.
2. CONTROLLING DIMENSION: MILLIMETER.
3. DIMENSION A AND B DO NOT INCLUDE MOLD PROTRUSION.
4. MAXIMUM MOLD PROTRUSION 0.15 (0.006) PER SIDE.
5. DIMENSION D DOES NOT INCLUDE DAMBAR PROTRUSION. ALLOWABLE DAMBAR PROTRUSION SHALL BE 0.127 (0.005) TOTAL IN EXCESS OF THE D DIMENSION AT MAXIMUM MATERIAL CONDITION.
6. 751-01 THRU 751-06 ARE OBSOLETE. NEW STANDARD IS 751-07.

DIM	MILLIMETERS		INCHES	
	MIN	MAX	MIN	MAX
A	4.80	5.00	0.189	0.197
B	3.80	4.00	0.150	0.157
C	1.35	1.75	0.053	0.069
D	0.33	0.51	0.013	0.020
G	1.27 BSC		0.050 BSC	
H	0.10	0.25	0.004	0.010
J	0.19	0.25	0.007	0.010
K	0.40	1.27	0.016	0.050
M	0°	8°	0°	8°
N	0.25	0.50	0.010	0.020
S	5.80	6.20	0.228	0.244

### SOLDERING FOOTPRINT\*

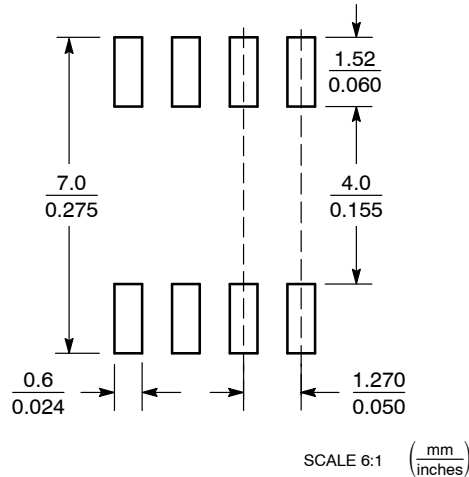

\*For additional information on our Pb-Free strategy and soldering details, please download the ON Semiconductor Soldering and Mounting Techniques Reference Manual, SOLDERRM/D.

ON Semiconductor and are trademarks of Semiconductor Components Industries, LLC dba ON Semiconductor or its subsidiaries in the United States and/or other countries. ON Semiconductor owns the rights to a number of patents, trademarks, copyrights, trade secrets, and other intellectual property. A listing of ON Semiconductor's product/patent coverage may be accessed at [www.onsemi.com/site/pdf/Patent-Marking.pdf](http://www.onsemi.com/site/pdf/Patent-Marking.pdf). ON Semiconductor reserves the right to make changes without further notice to any products herein. ON Semiconductor makes no warranty, representation or guarantee regarding the suitability of its products for any particular purpose, nor does ON Semiconductor assume any liability arising out of the application or use of any product or circuit, and specifically disclaims any and all liability, including without limitation special, consequential or incidental damages. Buyer is responsible for its products and applications using ON Semiconductor products, including compliance with all laws, regulations and safety requirements or standards, regardless of any support or applications information provided by ON Semiconductor. "Typical" parameters which may be provided in ON Semiconductor data sheets and/or specifications can and do vary in different applications and actual performance may vary over time. All operating parameters, including "Typicals" must be validated for each customer application by customer's technical experts. ON Semiconductor does not convey any license under its patent rights nor the rights of others. ON Semiconductor products are not designed, intended, or authorized for use as a critical component in life support systems or any FDA Class 3 medical devices or medical devices with a same or similar classification in a foreign jurisdiction or any devices intended for implantation in the human body. Should Buyer purchase or use ON Semiconductor products for any such unintended or unauthorized application, Buyer shall indemnify and hold ON Semiconductor and its officers, employees, subsidiaries, affiliates, and distributors harmless against all claims, costs, damages, and expenses, and reasonable attorney fees arising out of, directly or indirectly, any claim of personal injury or death associated with such unintended or unauthorized use, even if such claim alleges that ON Semiconductor was negligent regarding the design or manufacture of the part. ON Semiconductor is an Equal Opportunity/Affirmative Action Employer. This literature is subject to all applicable copyright laws and is not for resale in any manner.

### PUBLICATION ORDERING INFORMATION

**LITERATURE FULFILLMENT:**  
Literature Distribution Center for ON Semiconductor  
19521 E. 32nd Pkwy, Aurora, Colorado 80011 USA  
**Phone:** 303-675-2175 or 800-344-3860 Toll Free USA/Canada  
**Fax:** 303-675-2176 or 800-344-3867 Toll Free USA/Canada  
**Email:** [orderlit@onsemi.com](mailto:orderlit@onsemi.com)

**N. American Technical Support:** 800-282-9855 Toll Free  
USA/Canada  
**Europe, Middle East and Africa Technical Support:**  
Phone: 421 33 790 2910

**ON Semiconductor Website:** [www.onsemi.com](http://www.onsemi.com)  
**Order Literature:** <http://www.onsemi.com/orderlit>

For additional information, please contact your local Sales Representative